

Fluid and Motion Control - eBook

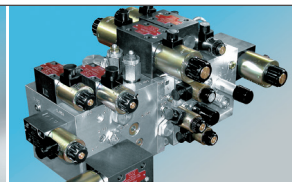

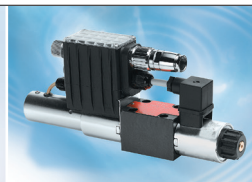

Fluid and Motion Control

The competence of ARGO-HYTOS in the field of Fluid and Motion Control of hydraulics systems is the result of more than 50 years of experience. Standing in the center is a broad program of valves, power packs and system blocks in well established designs and functions including proportional valves and electronic controllers:

- Subplate mounted flow, pressure and check valves in sizes 04 to 10
- Directly operated directional control valves in sizes 04 to 10 and pilot operated directional valves in sizes 16 and 25
- Cartridge valves
- Directly operated proportional valves with and without position feedback in sizes 04 to 10
- Analogue and digital electronic controllers on-board mounted or external controllers.
- Customized hydraulic power units, and a modular kit for hydraulic power packs
- System blocks

A further focal point of our activities is the development of custom-built solutions which are based on proven and tested technologies and matched to the particular application.

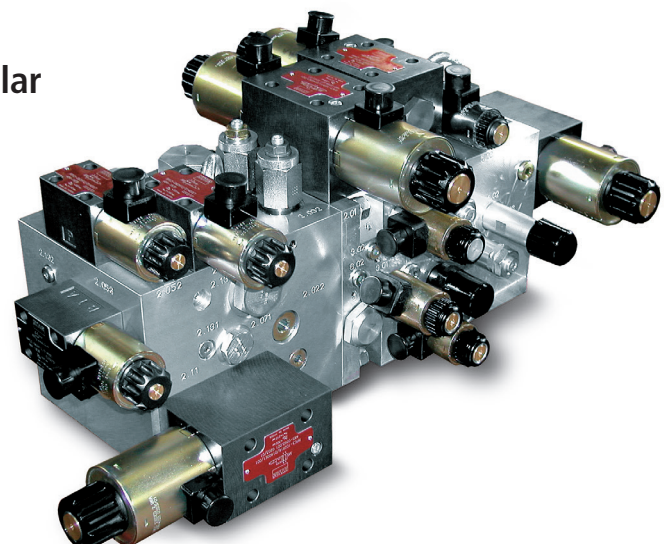

1 Directional Valves 1.01 - 1.27

2 Check Valves 2.01 - 2.22

3 Pressure Valves 3.01 - 3.20

4 Flow Valves 4.01 - 4.16

5 Overcentre Valves 5.01 - 5.14

6 Proportional Valves 6.01 - 6.21

7 Hydraulic Power Packs 7.01 - 7.03

8 Accessories, Connecting Plates 8.01 - 8.17

Directional Valves



1 Directional Valves

Symbol example	Flow l/min (GPM)	Pressure bar (PSI)	Type Code	Cartridge	NG3	NG4	NG6	NG10	NG16	NG25	Line Mounted	Page	Data Sheet
4/2 and 4/3 Manually Operated Directional Control Valves													
	30 (8)	320 (4600)	RPR3-04			X						1.01	HA 4018
	80 (21)	350 (5100)	RPR3-06				X					1.02	HA 4004
4/2 and 4/3 Hydraulic Operated Directional Control Valves													
	80 (21)	350 (5100)	RPH2-06				X					1.03	HA 4005
	80 (21)	350 (5100)	RPH3-06				X					1.04	HA 4006
4/2 and 4/3 Solenoid Operated Directional Control Valves													
	20 (5)	250 (3600)	RPEK1-03		X							1.05	HA 4027
	60 (16)	250 (3600)	RPEK1-03/B		X							1.06	HA 4057
	30 (8)	320 (4600)	RPE3-04			X						1.07	HA 4014
	50 (13)	250 (3600)	RPEL1-06				X					1.08	HA 4056
	80 (21)	350 (5100)	RPE3-06				X					1.09	HA 4010
	80 (21)	350 (5100)	RPEA3-06				X					1.10	HA 4029
	80 (21)	350 (5100)	RPEW4-06				X					1.11	HA 4035
	140 (37)	350 (5100)	RPE4-10					X				1.12	HA 4039
	140 (37)	350 (5100)	RPEW4-10					X				1.13	HA 4044
4/2 and 4/3 Pilot Operated Directional Control Valves													
	300 (79)	320 (4600)	RPEH4-16						X			1.14	HA 4023
	600 (159)	320 (4600)	RPEH4-25							X		1.15	HA 4024
2/2 Solenoid Operated Directional Control Valves Spool Type													
	30 (8)	350 (5100)	SD2E-A2	X		(X)					(X)	1.17	HA 4040
	60 (16)	350 (5100)	SD2E-B2	X			(X)				(X)	1.23	HA 4060
3/2 Solenoid Operated Directional Control Valves Spool Type													
	30 (8)	80 (1200)	PD2E	X								1.16	HA 4050
	30 (8)	350 (5100)	SD2E-A3	X		(X)					(X)	1.18	HA 4041
	60 (16)	350 (5100)	SD2E-B3	X			(X)				(X)	1.24	HA 4061
4/2 Solenoid Operated Directional Control Valves Spool Type													
	30 (8)	350 (5100)	SD2E-A4	X							(X)	1.19	HA 4042
	60 (16)	350 (5100)	SD2E-B4	X							(X)	1.25	HA 4062
2/2 Solenoid Operated Directional Control Valves Poppert Type													
	30 (8)	420 (6100)	SD3E-A2	X		(X)					(X)	1.21	HA 4043
	63 (13)	250 (3600)	ROE3-04	X		(X)	(X)				(X)	1.27	HA 4022
	75 (20)	420 (6100)	SD3E-B2	X			(X)				(X)	1.26	HA 4063
2/2 Solenoid Operated Directional Control Valves Poppert Type													
	25 (7)	250 (3600)	ROE3-04	X		(X)	(X)				(X)	1.27	HA 4022
	30 (8)	350 (5100)	SD1E-A2	X		(X)					(X)	1.20	HA 4070
2/2 Manually Operated Directional Control Valves Poppert Type													
	20 (5)	250 (3600)	SD1M-A2	X		(X)					(X)	1.22	HA 4051

- 4/3 and 4/2- way spool type directional control valves
- Hand-lever operated
- Actuating section can be rotated in four positions 90° apart
- Installation dimensions according to DIN 24 340 / ISO 4401 / CETOP RP121-H

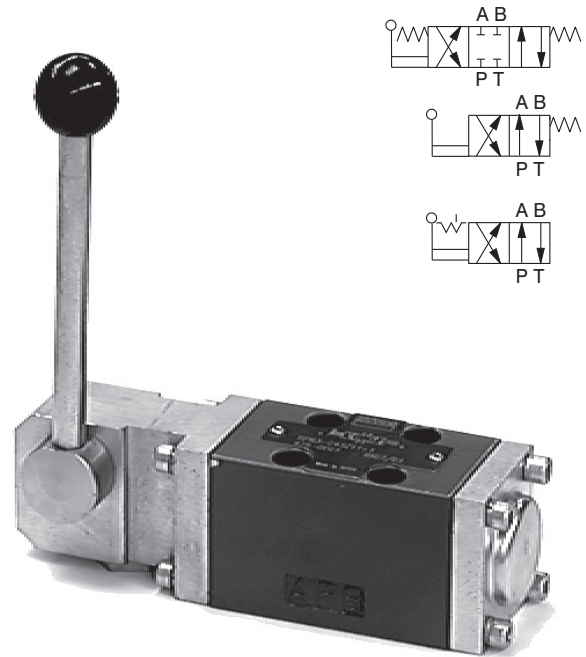

Functional Description

The hand operated directional control valves are used mainly to control start, stop and direction of fluid. The valves consist of housing (1) with control spool (2) and the actuating section (3). The actuating section consists either of the hand lever (4) and of one or two return springs (5), or of the hand lever (4) and the detent assembly (6). The detent assembly holds the spool in its last shifted position.

The directional control valves are being manufactured as two-position and three-position valves (see table with functional symbols).

The valve housing (1) is phosphate coated, the components of the actuating section (3) are zinc coated.

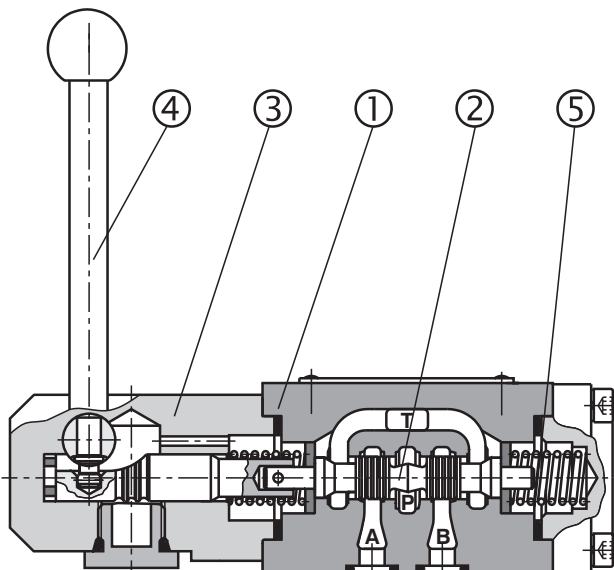

Type with return springs

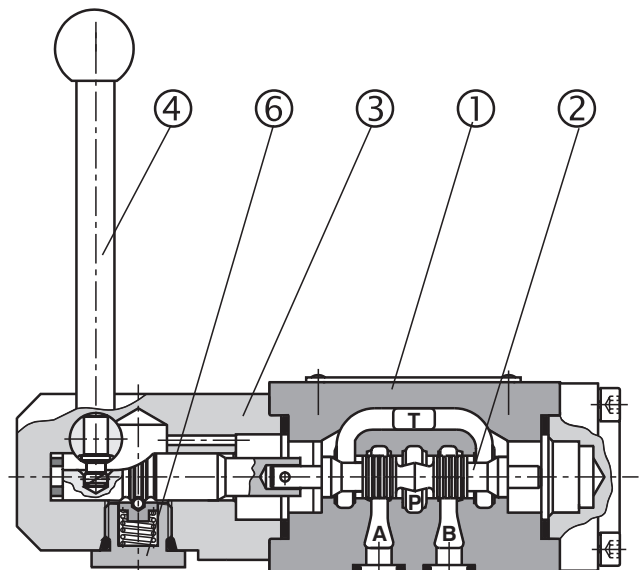

Type with detent assembly

Ordering Code

RPR3-04 -

Directional control valves manually operated

Valve size **04 (D 02)**

Number of operating positions

two positions **2**
three positions **3**

no designation
V

Seals
NBR
FPM (Viton)

Spool symbols
see table spool symbols

Technical Data

Valve size	mm (US)	04 (D 02)
Maximum flow	L/min (GPM)	30 (8.0)
Maximum operating pressure at ports P, A, B	bar (PSI)	320 (4600)
Maximum operating pressure at port T	bar (PSI)	100 (1450)
Pressure losses	bar (PSI)	see p-Q characteristics
Hydraulic fluid		Hydraulic oils of power classes (HL, HLP) to DIN 51524
Fluid temperature range for standard seal (NBR)	°C (°F)	-30 ... +100 (-22 ... +212)
Fluid temperature range for Viton sealing (FPM)	°C (°F)	-20 ... +120 (-4 ... +248)
Viscosity range	mm ² /s (SUS)	20 ... 400 (98 ... 1840)
Maximum degree of fluid contamination		Class 21/18/15 to ISO 4406
Operating force on lever	N (lbf)	< 40 (<8.99)
Service life	cycles	10 ⁶
Weight	kg (lbs)	1.0 (2.21)
Mounting position		unrestricted

Spool Symbols

Type	Symbol	Crossover	Type	Symbol	Crossover
Z11			Z15		
C11			C15		
H11			H15		
P11			P15		
Y11			Y15		
B11			B15		
L11			L15		
L21			L25		

Spool Symbols

Type	Symbol	Crossover	Type	Symbol	Crossover
Y31			Y35		
Y71			Y75		
R11			J15		
A51			J75		
R21			R25		

p-Q Characteristic

Measured at $v = 32 \text{ mm}^2/\text{s}$ (156 SUS)

Operating limits for maximum hydraulic power transferred by the directional valve.

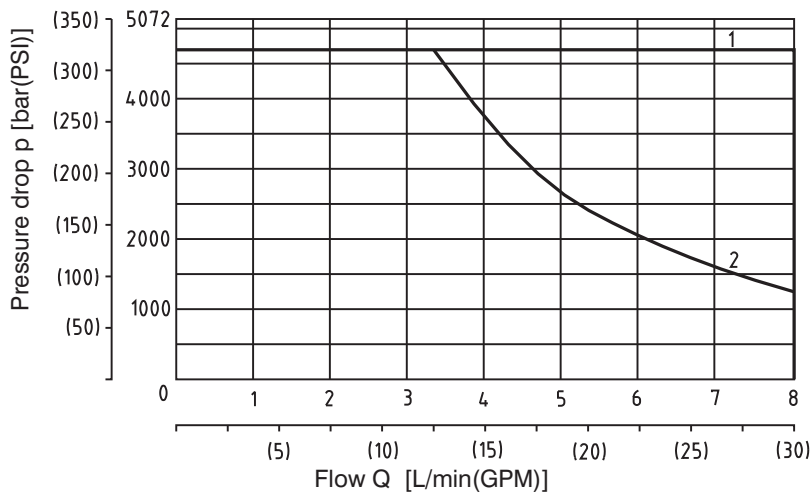

Z11	1	Z15	1
C11	1	C15	1
H11	1	H15	1
P11	1	P15	1
Y11	1	Y15	1
B11	1	B15	1
L11	2	L15	1
L21	2	L25	1
Y31	1	Y35	1
Y71	1	Y75	1
R11	1	J15	1
A51	1	J75	1
R21	1	R25	1

Δp -Q Characteristic

Measured at $v = 32 \text{ mm}^2/\text{s}$ (156 SUS)

Pressure drop Δp related to flow rate.

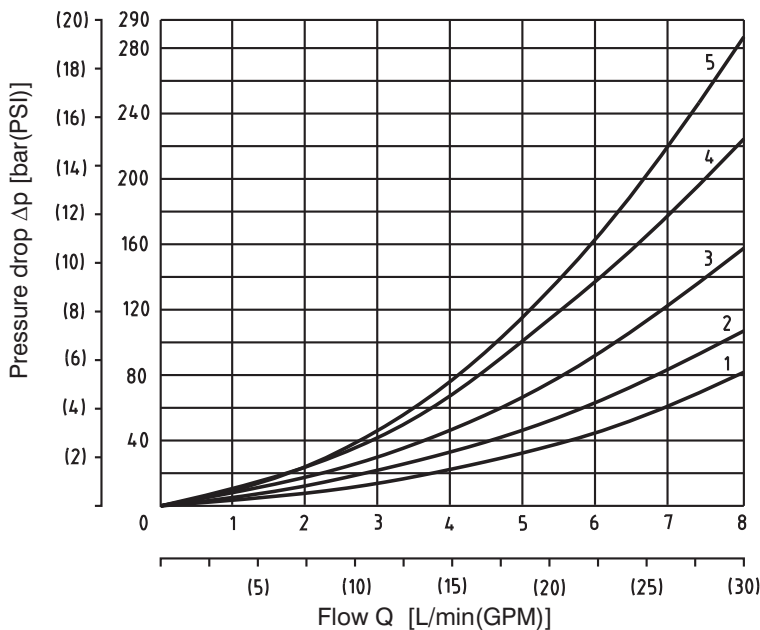

	P-A	P-B	A-T	B-T	P-T
Z11, Z15	3	2	2	2	
C11, C15	5	5	4	4	3
H11, H15	3	3	2	2	3
P11, P15	1	1	1	3	
Y11, Y15	3	3	1	1	
B11, B15	3	3	2	1	
L11, L15	3	2	1	2	4
L21, L25	2	2	3	3	4
Y31, Y35	3	3	2	2	
Y71, Y75	3	1			
R11, J15	3	3	2	2	
A51, J75	2	2			
R21, R25	3	3	2	2	

Valve Dimensions

Dimensions in inches and millimeters (in brackets)

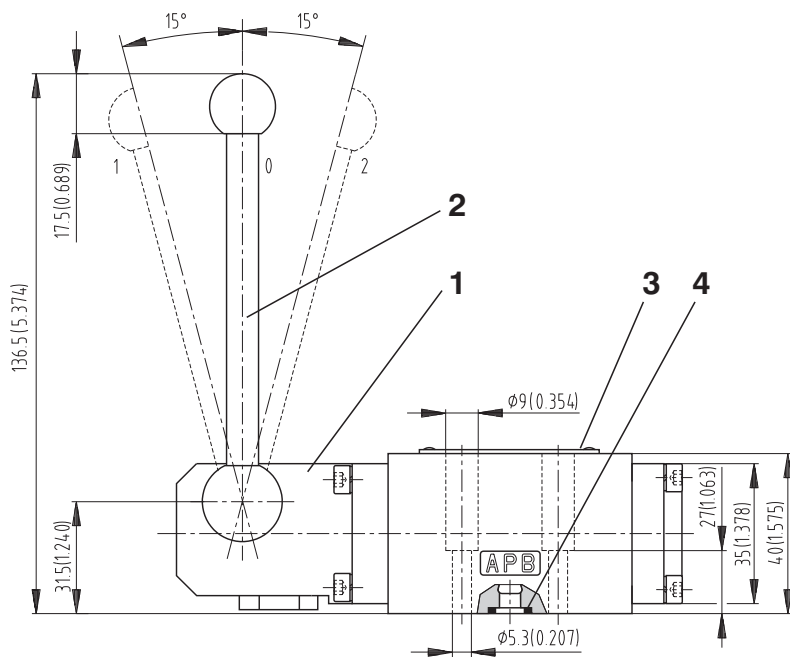
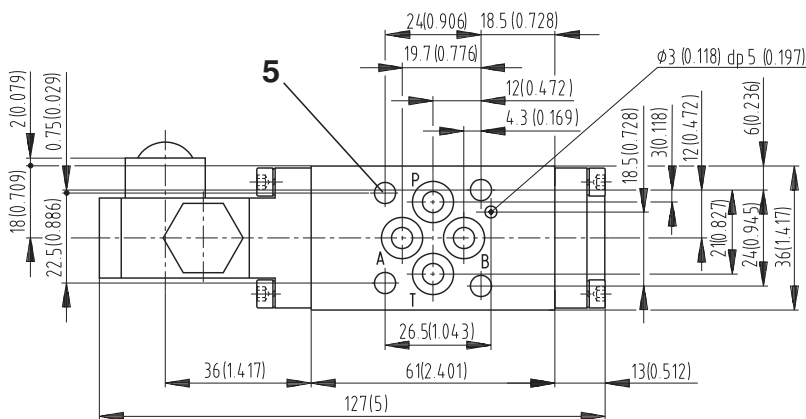

- 1 Actuating section
- 2 Hand lever
- 3 Name plate
- 4 Square ring 7.65x1.68 (4 pcs.) supplied with valve
- 5 4 mounting holes

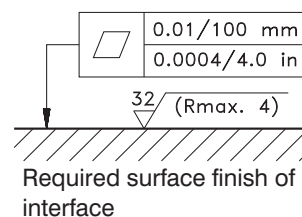

Spare Parts

Dimensions in millimeters

Seal kit

Type	Dimensions, quantity				Ordering number
	O-ring	Square ring	O-ring	O-ring	
Standard NBR70	22 x 2 (2 pcs.)	7.65 x 1.68 (4 pcs.)	11 x 1.5 (2 pcs.)	11.3 x 2.4 (1 pc.)	15673600
Viton	22 x 2 (2 pcs.)	7.65 x 1.68 (4 pcs.)	11 x 1.5 (2 pcs.)	11.3 x 2.4 (1 pc.)	20897200

Bolt kit (for studs see HA 0020)

Dimensions, quantity	Bolt torque	Ordering number
M5x35 DIN 912-10.9 (4 pcs.)	3.7 ft-lbs (5 Nm)	15874600

Caution!

- Directional valves with other functional symbols as those shown in the table above can be delivered on request.
- The plastic packaging is recyclable.
- Mounting bolts or studs must be ordered separately.
- Certified documentation is available per request.

ARGO-HYTOS s.r.o. CZ - 543 15 Vrchlabí
 Tel.: +420-499-403111, Fax: +420-499-403421
 E-mail: sales.cz@argo-hytos.com
 www.argo-hytos.com

- 4/3 and 4/2 - way spool type directional control valves
- Hand-lever operated
- Actuating section can be rotated in four positions 90° apart
- Installation dimensions to DIN 24 340 / ISO 4401 / CETOP RP121-H

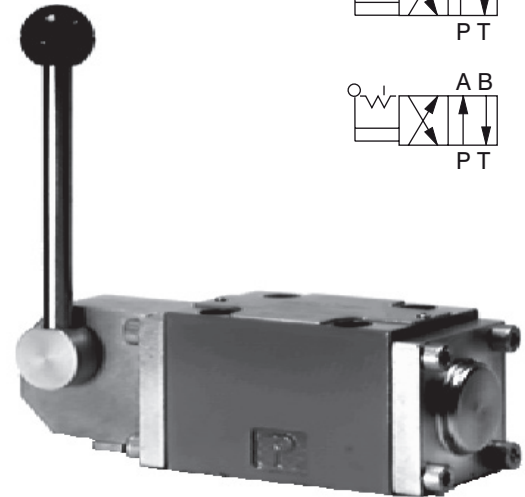
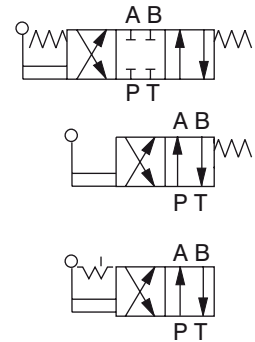

Functional Description

The hand operated directional control valves are used mainly to control start, stop and direction of fluid. The valves consist of housing (1) with control spool (2) and the actuating section (3). The actuating section consists either of the hand lever (4) and of one or two return spring (5), or of the hand lever (4) and the detent assembly (6). The detent assembly holds the spool in its last shifted position.

The directional control valves are being manufactured as two-position and three-position valves (see table with functional symbols).

The valve housing (1) is phosphate coated, the components of the actuating section (3) are zinc coated.

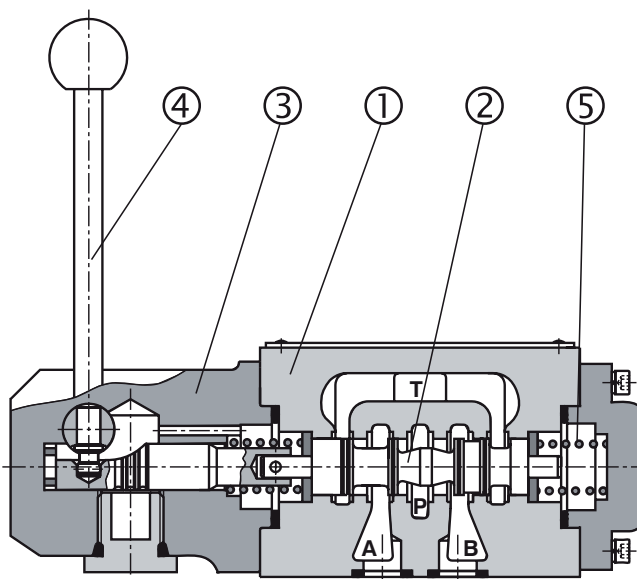

Type with return springs

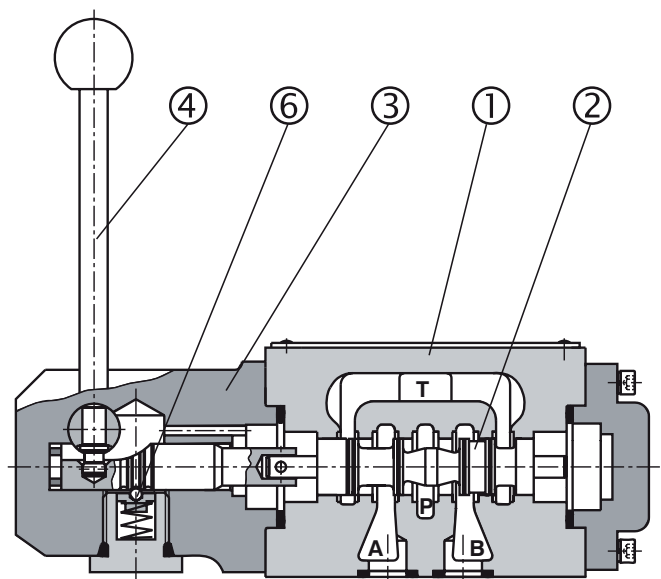

Type with detent assembly

Ordering Code

RPR3-06



Directional Control Valves Manually Operated

Valve size

Number of valve positions

two positions

three positions

2

3

no designation

V

Seals

NBR

FPM (Viton)

Spool symbols

see the table spool symbols

Technical Data

Valve size	mm (US)	06 (D 03)
Maximum flow	L/min (GPM)	80 (21)
Maximum operating pressure at ports P, A, B	bar (PSI)	350 (5076)
Maximum operating pressure at port T	bar (PSI)	100 (1450)
Pressure drop	bar (PSI)	see Δp -Q characteristics
Hydraulic fluid		Hydraulic oils of power classes (HL, HLP) to DIN 51524
Fluid temperature range - NBR	°C (°F)	-30 ... +100 (-22 ... +21)
Fluid temperature range - Viton	°C (°F)	-20 ... +120 (-4 ... +248)
Viscosity range	mm ² /s (SUS)	20 ... 400 (98 ... 1840)
Maximum degree of fluid contamination		Class 21/18/15 to ISO 4406
Operating force on lever	Nm (lbf)	< 50 (< 10.8)
Service life	cycles	10 ⁶
Weight	kg (lbs)	1,6 (3.53)
Mounting position		unrestricted

Spool Symbols

Type	Symbol	Crossover	Type	Symbol	Crossover
Z11			Y11		
Z15			Y15		
C11			B11		
C15			B15		
H11			R11		
H15			J15		
P11			A51		
P15			J75		

p-Q Characteristic

Measured at $v = 32 \text{ mm}^2/\text{s}$ (156 SUS)

Operating limits for maximum hydraulic power transferred by the directional valve. For respective spool type - see spool symbols.

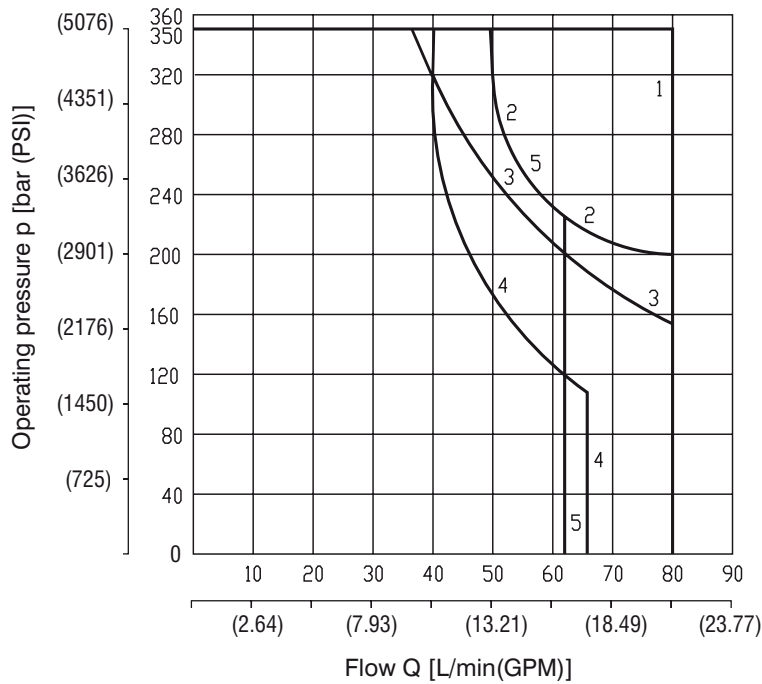

Z11	1	Z15	1
C11	4	C15	1
H11	3	H15	1
P11	1	P15	1
Y11	2	Y15	1
B11	5	B15	1
R11	1	J15	1
A51	3	J75	1

Δp-Q Characteristic

Measured at $v = 32 \text{ mm}^2/\text{s}$ (156 SUS)

Pressure drop Δp related to flow rate.

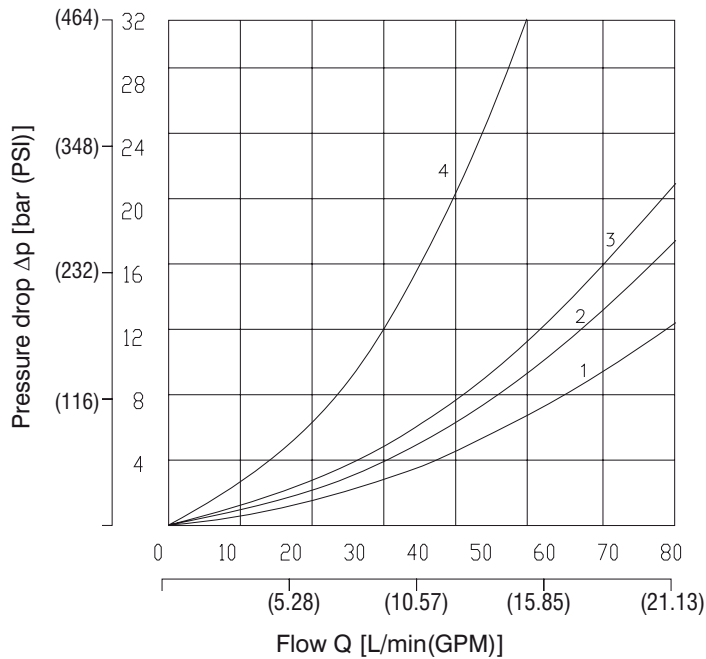

	P-A	P-B	A-T	B-T	P-T
Z11, Z15	2	2	3	3	
C11, C15	3	3	4	3	5
H11, H15	2	2	2	2	3
P11, P15	1	1	3	3	
Y11, Y15	2	2	2	2	
B11, B15	2	2	3	3	
R11, J15	2	2	3	3	
A51, J75	2	2			

Valve Dimensions

Dimensions in millimeters (inches)

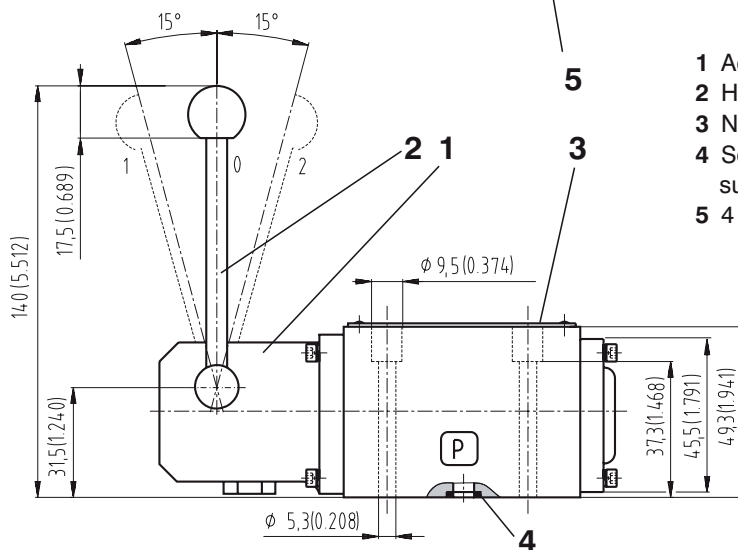
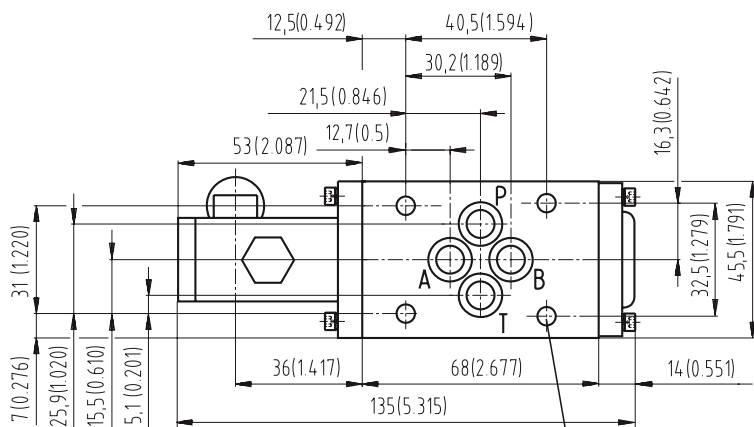

- 1 Actuating section
- 2 Hand lever
- 3 Name plate
- 4 Square ring (4 pcs.) 9.25 x 1.68 supplied with valve
- 5 4 mounting holes

Required surface finish of interface

Spare Parts

Dimensions in millimeters

Seal kit

Type	Dimensions, quantity	Ordering number
O-ring - NBR90	22 x 2 (2 pcs.)	15700300
Square ring - NBR70	9.25 x 1.68 (4 pcs.)	
O-ring - NBR70	11 x 1.5 (2 pcs.)	
O-ring - NBR70	11.3 x 2.4 (1 pc.)	

Bolt kit (for studs see HA 0030)

Dimensions, quantity	Bolt torque	Ordering number
M5 x 45 DIN 912-10.9 (4 pcs.)	8.9 Nm (6.6 ft-lbs)	15845100
10-24 UNCx1.75 (4 pcs.)		2 000 107

Caution!

- Directional valves with other functional symbols as those shown in the table above can be delivered on request.
- The plastic packaging is recyclable.
- Mounting bolts or studs must be ordered separately.
- Certified documentation is available per request.

ARGO-HYTOS s.r.o. CZ - 543 15 Vrchlaví
 Tel.: +420-499-403111, Fax: +420-499-403421
 E-mail: sales.cz@argo-hytos.com
 www.argo-hytos.com

- 4/3-, 4/2-way spool type directional valves hydraulically operated
- Installation dimensions to DIN 24 340 / ISO 4401 / CETOP RP121-H
- Three-chamber valve

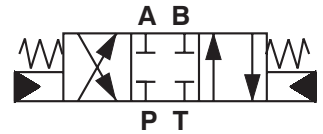

Functional Description

The directional control valves are of modular design and comprise a housing (1) with a cylindrical spool (2) and one or two operating elements (3) consisting of hydraulic pistons (4) and return springs (5). Three-position directional valves are fitted with two hydraulic operating elements and two centering

springs. Two-position directional valves have only one hydraulic operating element and one springs.

The basic surface treatment of valve is phosphate coated.

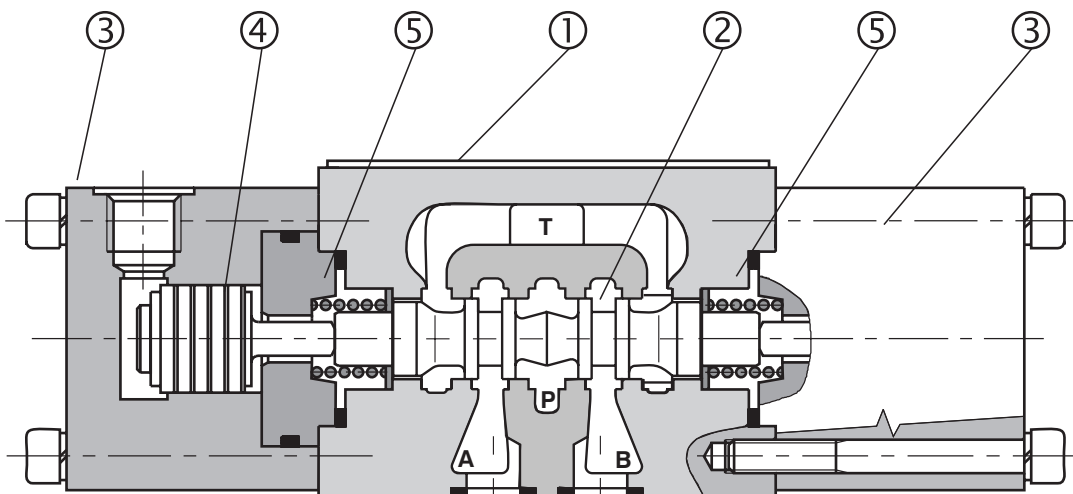

Ordering Code

RPH2-06 / -1

Directional control valves
hydraulically operated

Valve size **06 (D 03)**

Number of operating positions

two positions
three positions

2
3

Spool symbols

see the table spool symbols

no designation

V

Seals

NBR

FPM (Viton)

Model

Connecting threads

M10x1

G1/8

7/16-20 UNF-2B,SAE-4

1
2
3

Technical Data

Valve size	mm (US)	06 (D 03)
Maximum flow (according to pressure and functional symbols)	L/min (GPM)	see p-Q characteristic
Maximum operating pressure at ports P, A, B	bar (PSI)	350 (5076)
Maximum operating pressure at port T	bar (PSI)	130 (1885)
Minimum pilot pressure	bar (PSI)	30 (435) + pressure at port T
Maximum pilot pressure	bar (PSI)	160 (2300)
Pilot volume	cm ³ (cu.in.)	0,5(0.031)
Pressure drop	bar (PSI)	see Δp-Q characteristic
Hydraulic fluid		Hydraulic oils of power classes (HL, HLP) to DIN 51524
Fluid temperature range for standard sealing (NBR)	°C (°F)	-30 ... +100 (-22 ... +212)
Fluid temperature range for Viton seals (FPM)	°C (°F)	-20 ... +120 (-4 ... +248)
Viscosity range	mm ² /s (SUS)	20 ... 400 (98 ... 1840)
Maximum degree of fluid contamination		Class 21/18/15 to ISO 4406
Service life	cycles	10 ⁷
Weight valve with 1 actuator valve with 2 actuators	kg (lbs)	1,8 (3.96) 2,5 (5.50)
Mounting position		unrestricted

Spare Parts

Bolt kit			
Dimensions, quantity	Bolt torque		Ordering number
M5 x 45 DIN 912-10.9	8.9 Nm(6.6 ft-lbs)		15845100
10-24 UNC x1.75			2 000 107
Seal kit			
Dimensions in millimeters			
Type	Dimensions, quantity		Ordering number
	O-ring	Square ring	
Standard NBR	22 x 2 NBR90 (2 pcs.)	9.25 x 1.68 NBR70 (4 pcs.)	20980500
	28 x 2 (2 pcs.)	-	
Viton	22 x 2 (2 pcs.)	-	20980600
	9.25 x 1.78 (4 pcs.)	-	
	28 x 2 (2 pcs.)	-	

Spool Symbols

Type	Symbol	Crossover	Type	Symbol	Crossover
Z11			C51		
C11			H51		
H11			Y51		
Y11			Y11		
L21			H11		
R11			X11		
A51			Z11		
Z51			J15		

p-Q Characteristic

Measured at $v = 32 \text{ mm}^2/\text{s}$ (156 SUS)

Operating limits for maximum hydraulic power transferred by the directional valve. Measured by steering pressure 30 bar (435PSI) + pressure at port T. For respective spool type - see spool symbols.

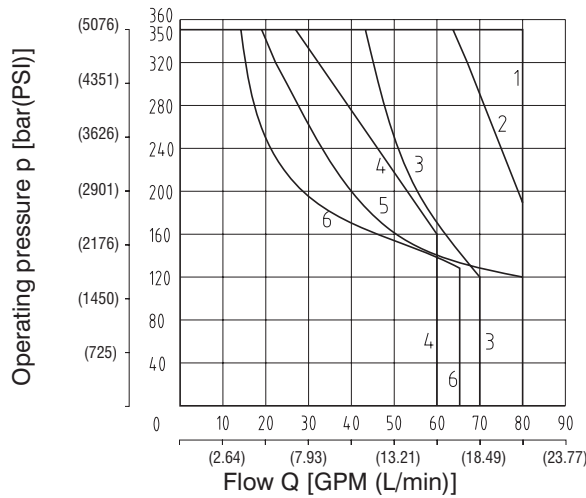

H11	1
H51	1
C11	1
C51	1
Z11	2
Z51	2
J15	3
R11	4
X11	4
A51	5
Y11	6
Y51	6

Δp -Q Characteristic

Measured at $v = 32 \text{ mm}^2/\text{s}$ (156 SUS)

Pressure drop Δp related to flow rate.

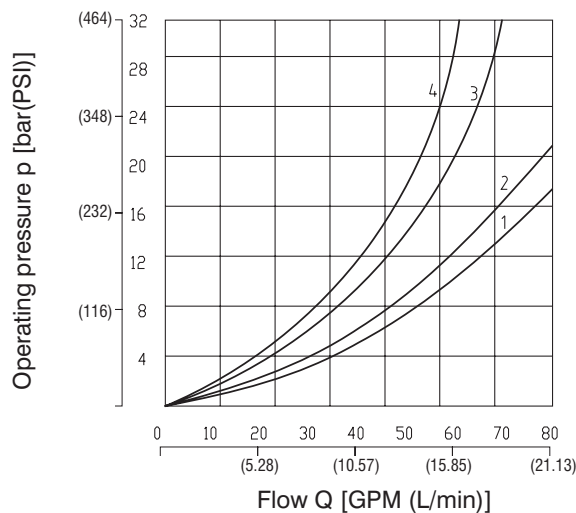

	P-A	P-B	A-T	B-T	P-T
Z11	1	1	2	2	
C11	3	3	3	4	2
H11	1	1	1	1	2
H51	1	1	1	1	2
Y11	1	1	1	1	
C51	3			4	2
Z51		1	2		
R11	1	1	2	2	
A51	1	1			
Y51		1	1		
X11	1	1	2	2	
J15	1	1	2	2	

Valve Dimensions

Dimensions in millimeters (inches)

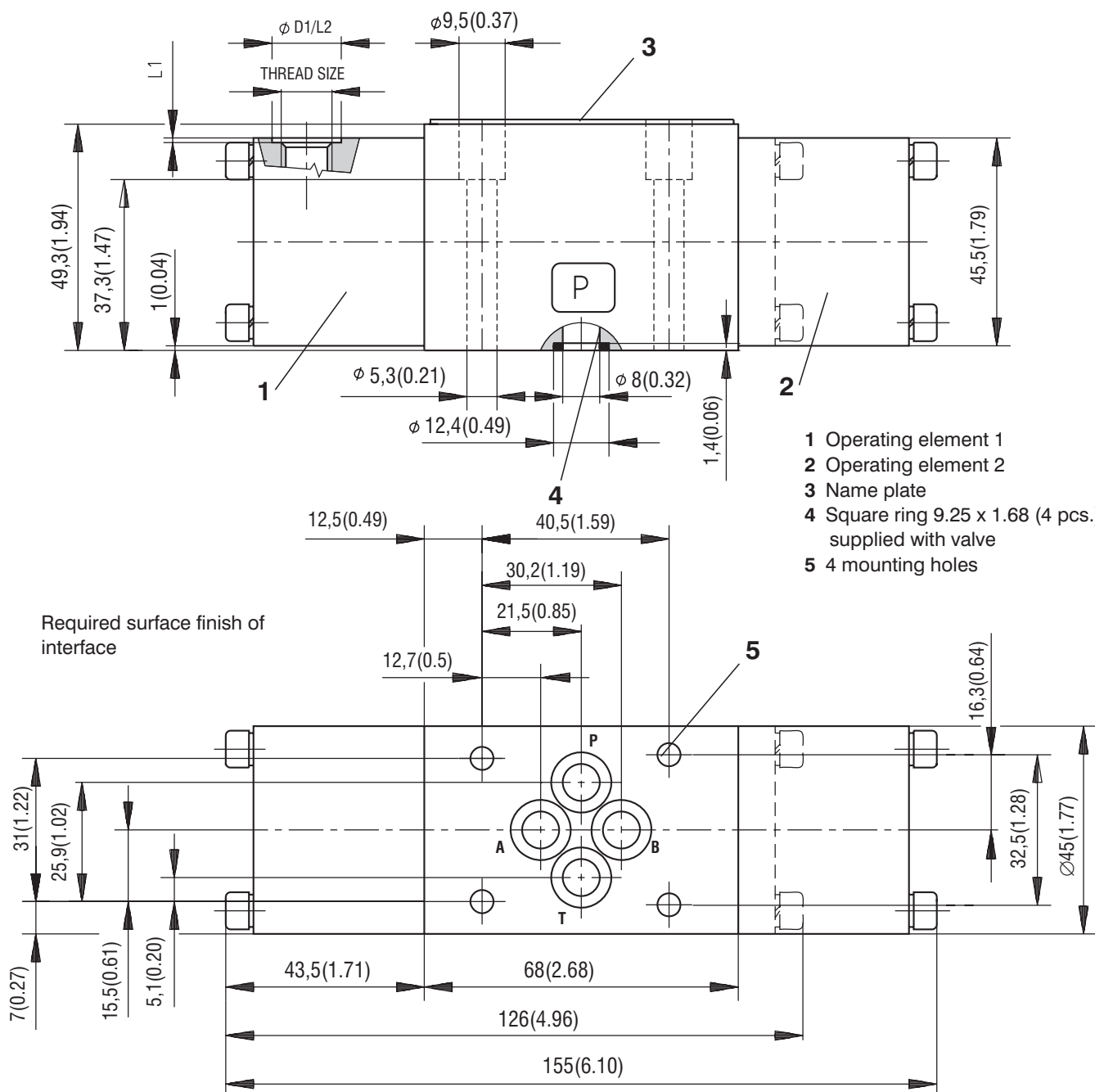

- 1 Operating element 1
- 2 Operating element 2
- 3 Name plate
- 4 Square ring 9.25 x 1.68 (4 pcs.) supplied with valve
- 5 4 mounting holes

Required surface finish of interface

Thread size	Ø D1	L1	L2
M10x1	15,5 (0.610)	1 (0.039)	8 (0.315)
G1/8			
7/16-20 UNF-2B, SAE-4	21 (0.827)	0,8 (0.032)	14 (0.551)

Caution!

- For applications outside the given parameters, please consult us.
- Other for spool symbols on request.
- The packing foil is recyclable.
- The protective plate can be returned to manufacturer.
- Mounting screws M5 x 45 DIN 912-10.9 or bolts must be ordered separately. The screws tightening torque is 8.9 Nm (6.6 ft-lbs).
- The technical information regarding the product presented in this catalogue is for descriptive purposes only. It should not be construed in any case as a guaranteed representation of the product properties in the sense of the law.

ARGO-HYTOS s.r.o. CZ - 543 15 Vrchlaví
 Tel.: +420-499-403111, Fax: +420-499-403421
 E-mail: sales.cz@argo-hytos.com
 www.argo-hytos.com

- 4/3, 4/2 way spool type directional valves hydraulic operated

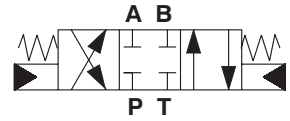

- Installation dimensions to DIN 24 340 / ISO 4401 / CETOP RP121-H

- Connecting threads M10x1, G1/8

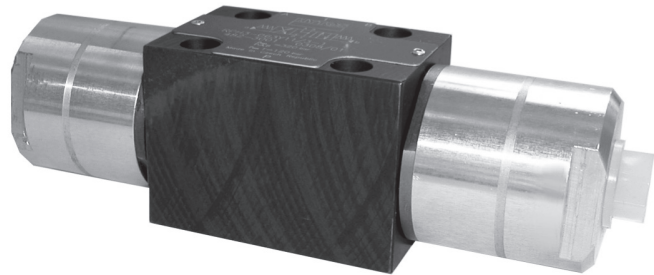

Functional Description

The directional control valves are of modular design and comprise a housing (1) with a cylindrical spool (2) and one or two operating elements (3) consisting of hydraulic pistons (4) and return spring (5).

Three-position directional valves are fitted with two hydraulic operating elements and two centering

springs. Two-position directional valves have only one hydraulic operating element and one springs.

The basic surface treatment of the valve housing is phosphate.

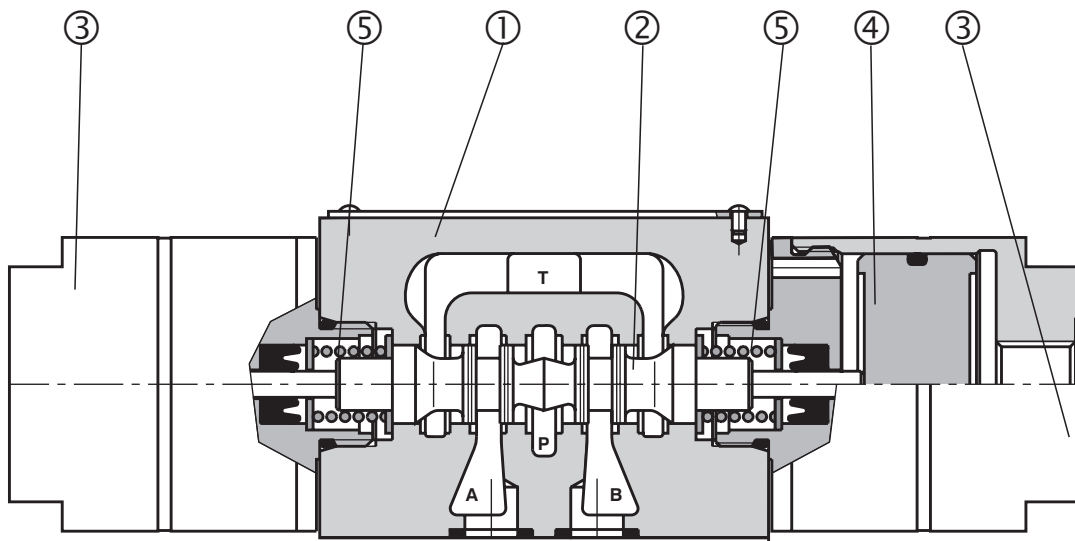

Ordering Code

RPH3-06 /

Hydraulic Operated Directional Control Valve

Nominal size

Number of operating positions

two positions

three positions

2
3

Functional symbols

see the table functional symbols

no designation

V

Seals

NBR

FPM (Viton)

Model

Hydraulic

Pneumatic

1
2

Connecting threads

M10x1

G1/8

1
2

Technical Data

Valve size	mm(US)	06
Maximum flow (according to pressure and functional symbols)	L/min (GPM)	see p-Q characteristics
Maximum operating pressure at ports P, A, B	bar (PSI)	350 (5076)
Maximum operating pressure at port T	bar (PSI)	160 (2321)
Minimum pilot pressure	bar (PSI)	2 (29)
Maximum pilot pressure	bar (PSI)	25 (362.6)
Pilot volume	cm ³ (cu.in.)	6,2 (0,378)
Pressure drop	bar (PSI)	see Δp-Q characteristics
Hydraulic fluid		Hydraulic oils of power classes (HL, HLP) to DIN 51524
Fluid temperature range for standard sealing (NBR)	°C (°F)	-30 ... +100 (-22 ... +21)
Fluid temperature range for Viton seals (FPM)	°C (°F)	-20 ... +120 (-4 ... +248)
Viscosity range	mm ² /s (SUS)	20 ... 400 (98 ... 1840)
Maximum degree of fluid contamination		Class 21/18/15 to ISO 4406
Service life	cycles	10 ⁷
Weight valve with 1 actuator valve with 2 actuators	kg (lbs)	1,8 (3.96) 2,5 (5.50)
Mounting position		unrestricted

Spare Parts

Seal kit			
Type	Dimensions, number		Ordering number
Standard NBR	9,25 x 1,68 NBR70 (4 pcs.)	17 x 1,8 (2 pcs.)	15845200
Viton	9,25 x 1,78 (4 pcs.)	17,17 x 1,78 (2 pcs.)	15845400
Mounting bolts			
Dimensions, number	Tightening torque		Ordering number
M5 x 45 DIN 912-10.9 (4 pcs.)	8.9 Nm (6.6 ft-lbf)		15845100

Functional Symbols

Three position directional valves RPH3-063			Two position directional valves RPH3-062		
Type	Symbol	Crossover	Type	Symbol	Crossover
Z11			R11		
C11			A51		
H11			P51		
P11			Y51		
Y11			X11		
L21			J15		
B11			J75		

p-Q Characteristics

Measured at $v = 32 \text{ mm}^2/\text{s}$ (156 SUS)

Operating limits for maximum hydraulic power transferred by the directional valve. Measured by steering pressure 2 bar (29 PSI). For respective spool type - see Functional Symbols.

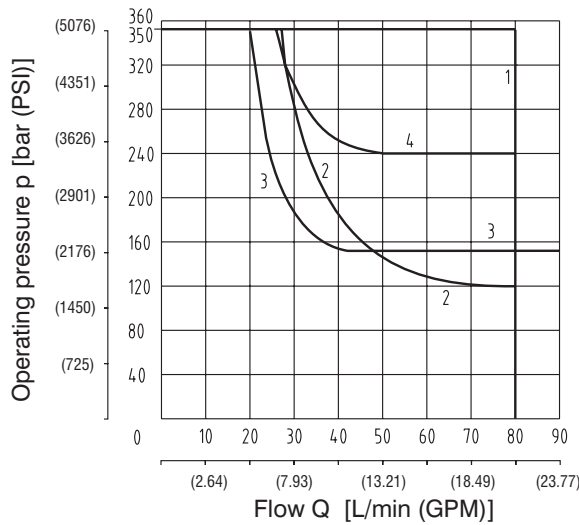

Z11	1
C11	2
H11	3
P11	1
Y11	1
L21	4
B11	1
R11	1
A51	1
P51	1
Y51	2
X11	1
J15	1
J75	1

Δp -Q Characteristics

Measured at $v = 32 \text{ mm}^2/\text{s}$ (156 SUS)

Pressure drop Δp related to flow rate.

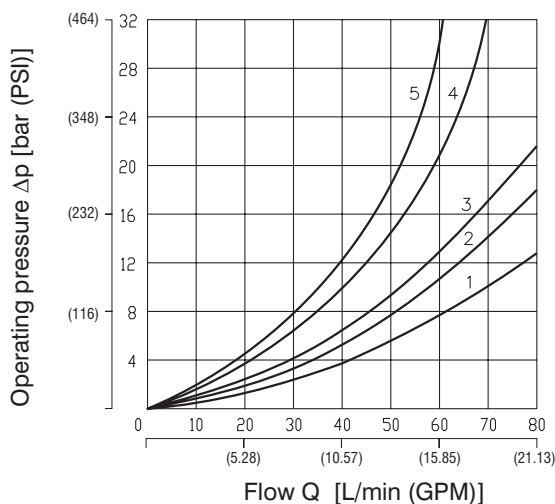

	P-A	P-B	A-T	B-T	P-T
Z11	2	2	3	3	
C11	4	4	4	5	3
H11	2	2	2	2	3
P11	1	1	3	3	
Y11	2	2	2	2	
L21	2	2	3	3	
B11	2	2	3	3	
R11	2	2	3	3	
A51	2	2			
P51		1	3		
Y51		2	2		
X11	2	2	3	3	
J15	2	2	3	3	
J75	2	2			

Valve Dimensions

Dimensions in millimeters (inches)

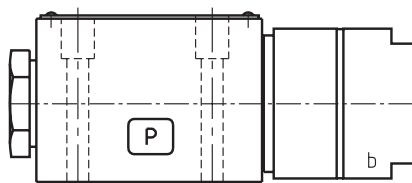
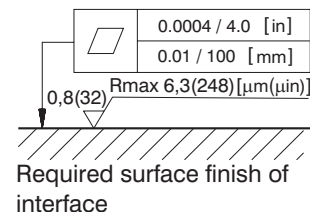
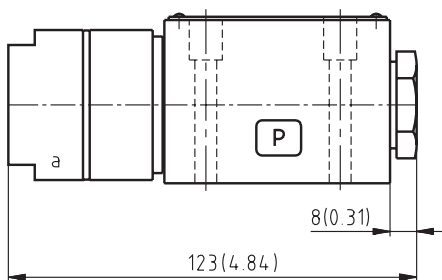
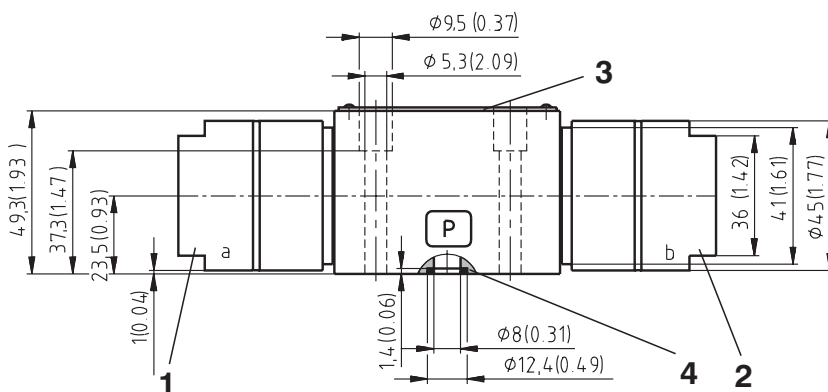
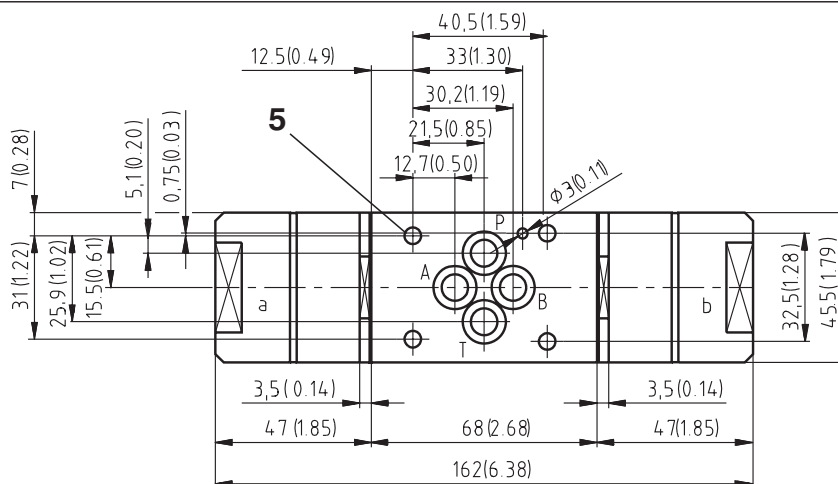

- 1 Operating element 1
- 2 Operating element 2
- 3 Name plate
- 4 Square ring 9.25 x 1.68 (4 pcs.)
supplied with each valve
- 5 4 mounting holes

Caution!

- For applications outside the given parameters, please consult us.
- Other for spool symbols on request.
- The packing foil is recyclable.
- The protective plate can be returned to manufacturer.
- Mounting screws M5 x 45 DIN 912-10.9 or bolts must be ordered separately.
The screws tightening torque is 8.9 Nm (6.6 ft-lbs).
- The technical information regarding the product presented in this catalogue is for descriptive purposes only. It should not be construed in any case as a guaranteed representation of the product properties in the sense of the law.

ARGO-HYTOS s.r.o. CZ - 543 15 Vrchlaví
 Tel.: +420-499-403111, Fax: +420-499-403421
 E-mail: sales.cz@argo-hytos.com
 www.argo-hytos.com

Size 03 • p_{max} 250 bar (3625 PSI) • Q_{max} 20 L/min (5.28 GPM)

Replaces
HA 4027 12/2007

- 4/3-, 4/2 way directional control valves with solenoid control
- Solenoids can be turned around their axis to any position
- Push button manual override
- Possibility of vertical and horizontal assembly, see data sheet HA 4057

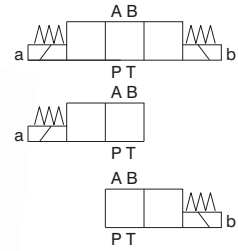

Functional Description

Distributors of the RPEK1-03 type are the basic elements for building blocks through horizontal and vertical assembly. This catalogue describes the preparation of the main unit, made up of two to eight distributors, by horizontal assembly. The distributors controlling the direction of the working fluid's flow to the individual appliances share common channels P and T. During the circuit design it is always necessary to check if the flow through the common channels covers the consumption of all appliances in all phases of the hydraulic equipment working cycle. Channels A, B outputs at the upper surface of the body are provided with threads G1/4 (type G), or SAE 9/16-18 (type S), or are prepared for vertical assembly (type O) – i.e. brought out onto a ground surface. Channels P, T, A, B outlets on the side surfaces of the body are prepared for horizontal assembly – i.e. brought out onto a ground surfaces or provided with a sealing ring recess.

The individual distributor bodies are connected into a compact block using three bolts. Fastening angles serve to mount the block to the base with four screws.

An assembled block feed is provided by a plate with connecting threads G3/8 in channels P, T. It is also possible to use plate with a built-in pressure relief valve to regulate the maximum pressure in the circuit.

Use data sheet No. HA 5027 to create more complex assemblies with the use of the horizontal and vertical assembly, while also using additional building elements.

The RPEK1-03 directional control valves consist of cast iron housing (1), control spool (5) with two centering springs (4) and operating solenoids (2, 3).

The three-position directional valves are fitted with two solenoids, two-position directional valves have either one solenoid.

*The operating solenoids are DC solenoids supplied through connectors A, B (6, 7). For AC supply the solenoids are provided with rectifiers, which are integrated directly into the connectors A, B (6, 7). The connectors can be turned by 90° around. By loosening the nut (8), the solenoid can be turned around its axis up to 360°.

In the case of solenoid malfunction or power failure, the spool of the valve can be repositioned by manual override (9), provided the pressure in the T-port does not exceed 25 bar. The standard design of the emergency control may be additionally fitted with a pushbutton with a rubber cover.

The basic surface treatment of the valve housing (1) is phosphate coated and the solenoids (2, 3) are zinc coated.

*Magnet coils are not included in the valve supply. The coil types selected by the customer must be ordered separately.

Type of connection
"O"

Type of connection
"G", "S"

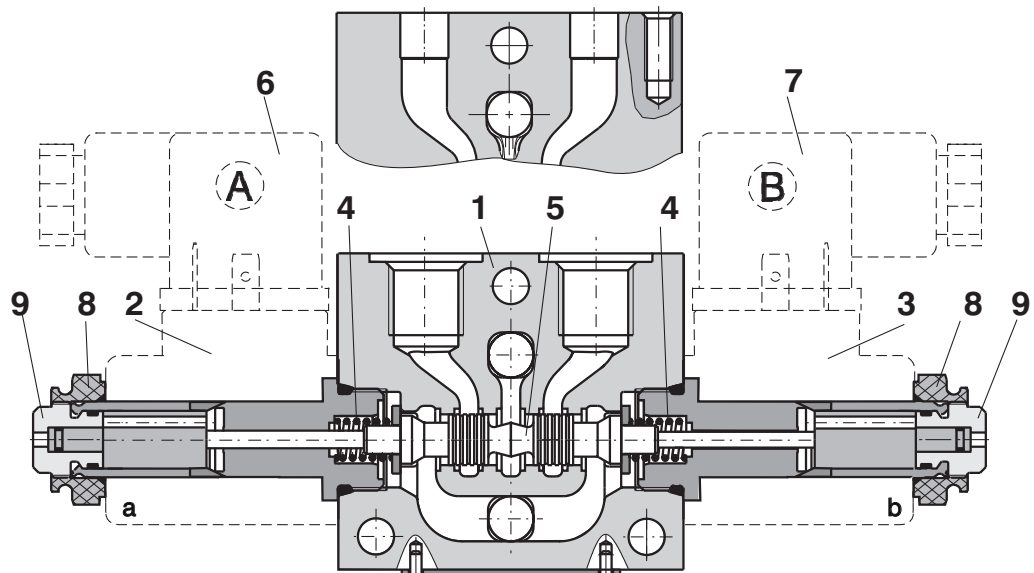

Ordering Code

RPEK1-03 /

**Solenoid Operated
Directional Control Valve**

Nominal size

Type of connection

G1/4

SAE 9/16-18

without thread

**G
S
O**

Number of valve positions

two positions

three positions

**2
3**

Functional symbols

see the table functional symbols

no designation

V

Seals

NBR

FPM (Viton)

Design form

standard

no designation

P1 through channels P, T; inlets A, B with sealing rings

Z1 one side inlets of channels P, T with sealing rings

Z3 one side inlets of channels P, T, A, B with sealing rings

Manual override *

standard

no designation

*The standard design of the manual override may be additionally fitted with a pushbutton with a rubber cover (N2).

Note: solenoid coil, electrical connector and manual override (N2) **is not supplied as mounted on**, must be ordered separately (see ordering number on page 6; 7 and 10)

Technical Data

Nominal size		03
Maximum flow	L/min (GPM)	see p-Q characteristics
Maximum operating pressure at ports P, A, B	bar (PSI)	250 (3625)
Maximum operating pressure at port T	bar (PSI)	210 (3045)
Pressure drop	bar (PSI)	see Δp -Q characteristics
Hydraulic fluid		Hydraulic oils of power classes (HL, HLP) to DIN 51 524
Fluid temperature range NBR	°C (°F)	-30 ... +80 (-22 ... +176)
Fluid temperature range FPM (Viton)	°C (°F)	-20 ... +80 (-4 ... +176)
Ambient temperature, max.	°C (°F)	up to +50 (+122)
Viscosity range	mm ² /s (SUS)	20 ... 400 (98 ... 1840)
Maximum degree of fluid contamination		Class 21/18/15 to ISO 4406
Maximum allowable voltage variation	%	AC: ± 10 DC: ± 10
Maximum switching frequency	1/h	15 000
Switching time, ON; at $v = 32$ mm ² /s	ms	30 ... 50
Switching time, OFF; at $v = 32$ mm ² /s	ms	AC: 70 ... 100 DC: 30 ... 50
Duty cycle	%	100
Service life	cycles	10 ⁷
Enclosure type to EN 60 529		see page 7
Weight		
- valve with 1 solenoid	kg (lb)	0.90 (1.98)
- valve with 2 solenoid		1,05 (2.32)
Mounting position		unrestricted

Functional Symbols

Designation	Symbol	Interposition	Designation	Symbol	Interposition
Z11			R21		
C11			Y51		
H11			C51		
Y11			Z51		
R11			H11		

p-Q Characteristic

Measured at $v = 32 \text{ mm}^2/\text{s}$ (156 SUS)

Operating limits for maximum hydraulic power transferred by the directional valve.

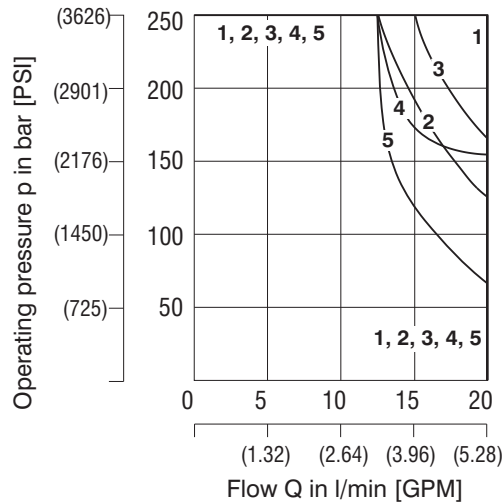

Z11	Z51	R11	R21	C11	C51	H11	Y11	Y51
1	1	1	5	2	2	3	4	4

Δp -Q Characteristic

Measured at $v = 32 \text{ mm}^2/\text{s}$ (156 SUS)

Pressure drop Δp related to flow rate.

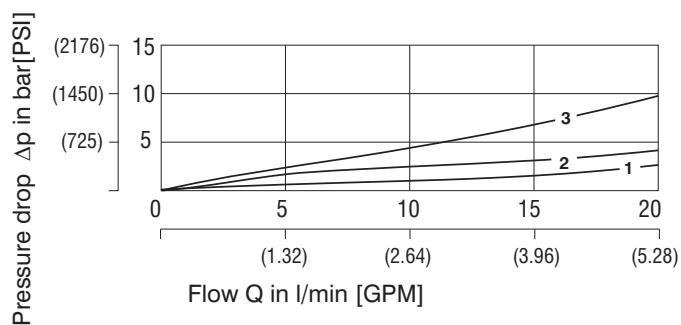

	Z11	C11	H11	Y11	R11	R21	Y51	C51	Z51
P-A	1	3	1	1	2	2		3	
P-B	1	3	1	1	2	2	1		1
A-T	1	3	1	1	2	2	1		1
B-T	1	3	1	1	2	2		3	
P-T		2	2					2	

Valve Dimensions Standard body version "G", "S"

Dimensions in millimeters (inches)

	G	S
THREAD	G1/4	SAE6 - 9/16-18UNF
∅D [mm]	∅20,9H13	∅ 25 +0,5
∅D [in]	0.823	0.984 +0.020
A [mm (in)]	1 (0.039)	0,5 (0.020)

Valve with two solenoids

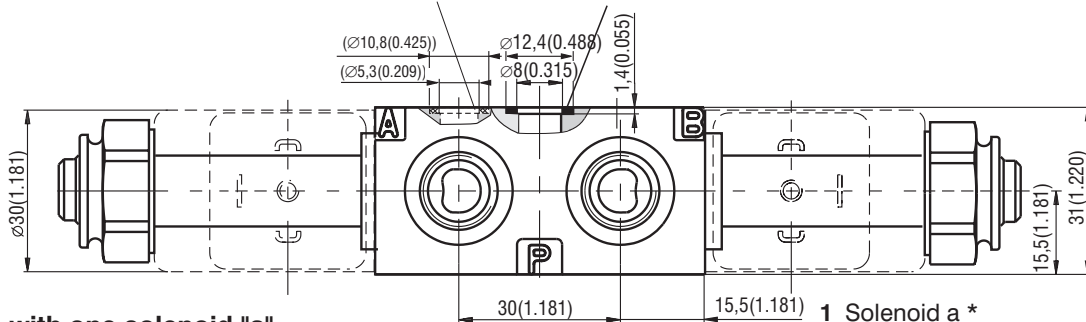
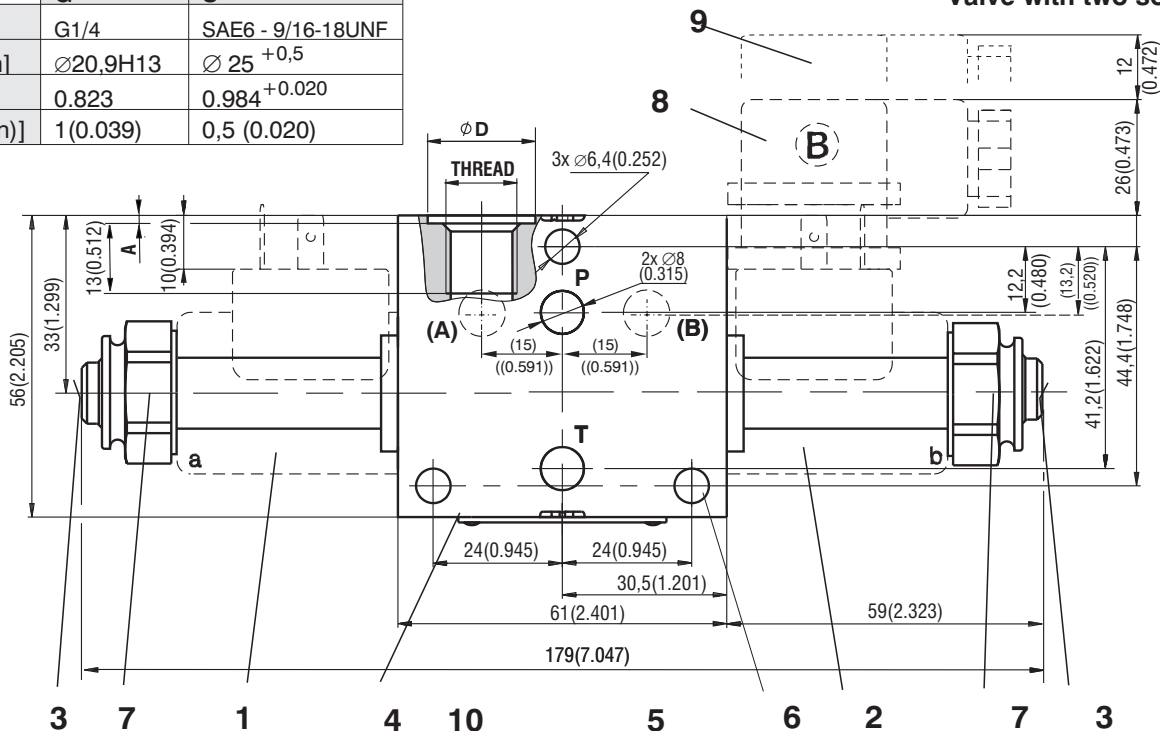

Valve with one solenoid "a"

Functional symbols R11, R21, Y51, C51, Z51

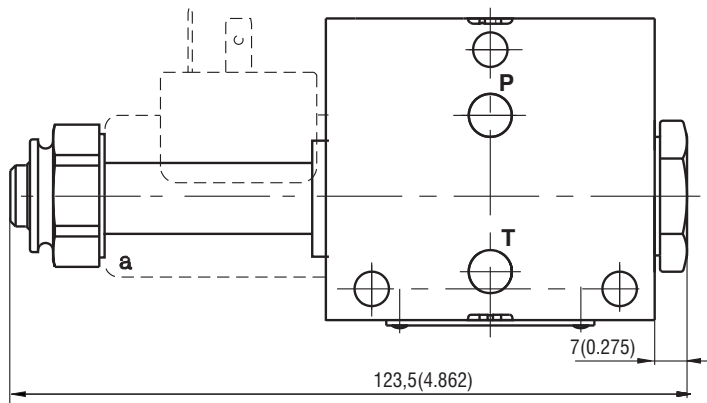

Valve with one solenoid "b"

Functional symbols H11

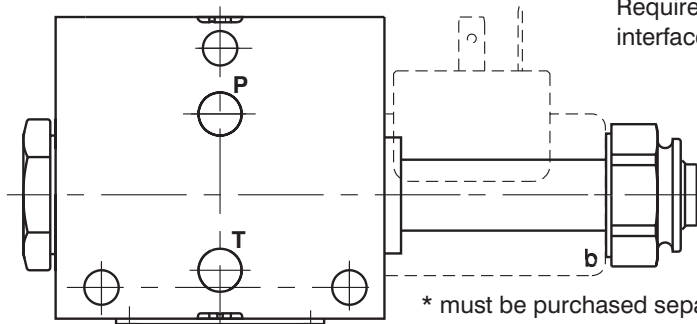

- 1 Solenoid a *
- 2 Solenoid b *
- 3 Manual override
- 4 Name plate
- 5 Square ring 9,25 x 1,68 (2 pcs) supplied with valve
- 6 3 mounting holes
- 7 Retaining nut of the solenoid
- 8 Electrical connector, EN 1745301-803
- 9 Space required to remove connector
- 10 Outlets A/B are only at the versions P1, Z1; Z3, Seal 7,65x1,68

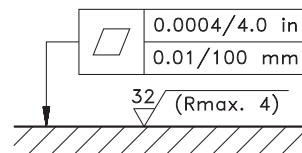

Required surface finish of interface

* must be purchased separately (see page 7)

Valve Dimensions Standard body version "O"

Dimensions in millimeters (inches)

1

Valve with two solenoids

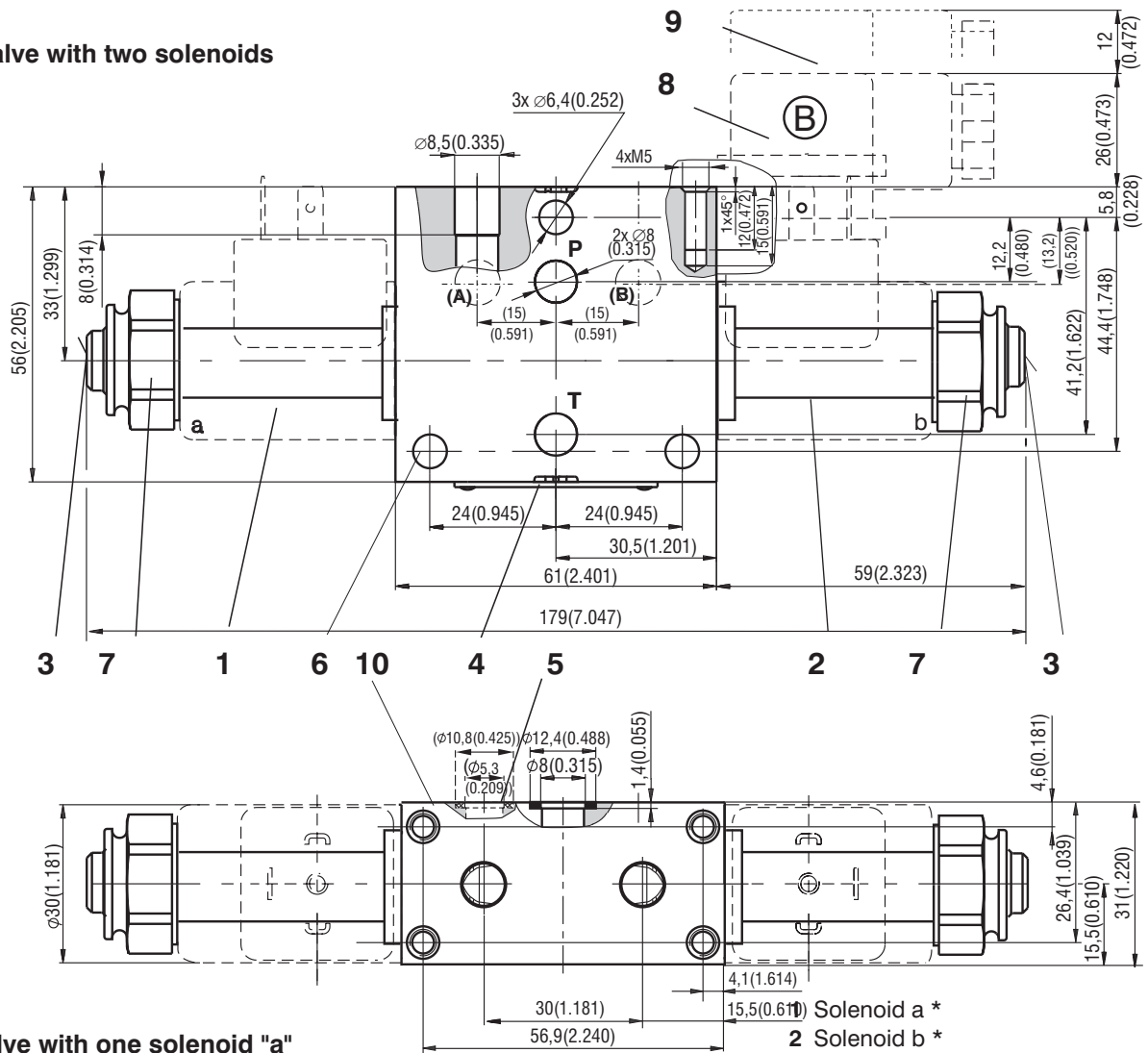

Valve with one solenoid "a"

Functional symbols R11, R21, Y51, C51, Z51

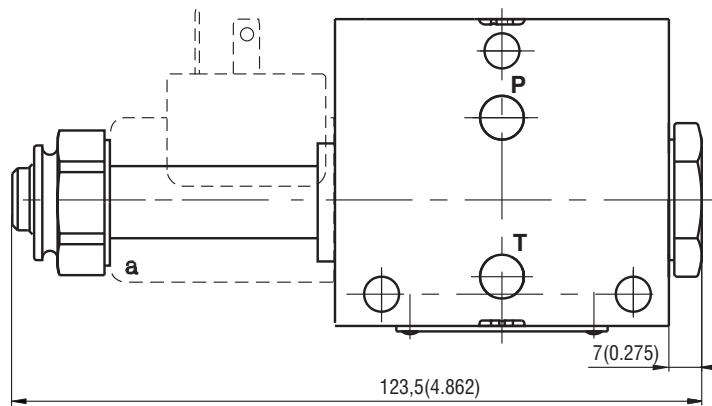

Valve with one solenoid "b"

Functional symbols H11

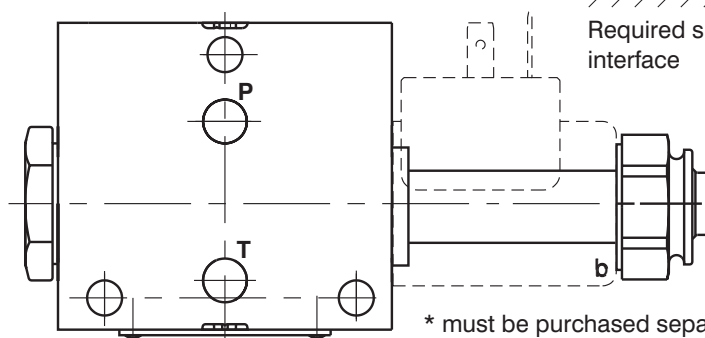

- 1 Solenoid a *
- 2 Solenoid b *
- 3 Manual override
- 4 Name plate
- 5 Square ring 9,25 x 1,68 (2 pcs) supplied with valve
- 6 3 mounting holes
- 7 Retaining nut of the solenoid
- 8 Electrical connector, EN 1745301-803
- 9 Space required to remove connector
- 10 Outlets A/B are only at the versions P1, Z1; Z3, Seal 7,65x1,68

* must be purchased separately (see page 7)

Design form "G" ("S"), "O"

P1 - "G" ("S")

through channels P, T; outlets A, B with sealing rings

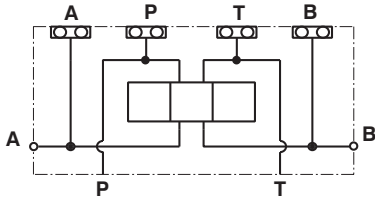
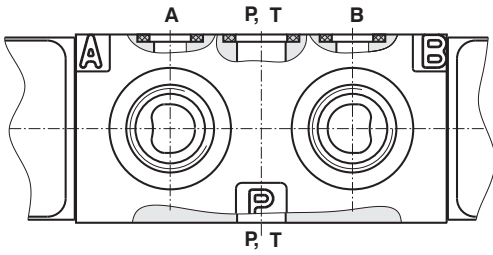

P1 - "O"

4xM5 for vertical assembly

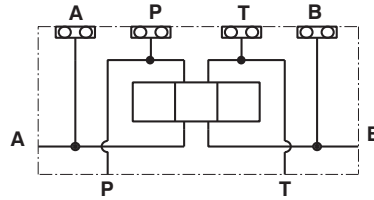
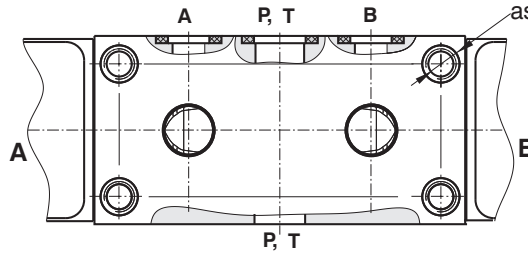

Z1 - "G" ("S")

one side inlets of channels P, T with sealing rings (outlets A, B only on the upper surface)

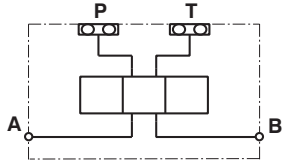
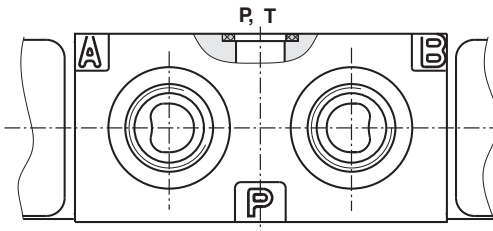

Z1 - "O"

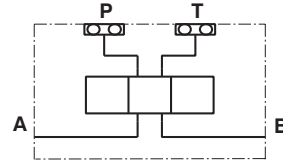
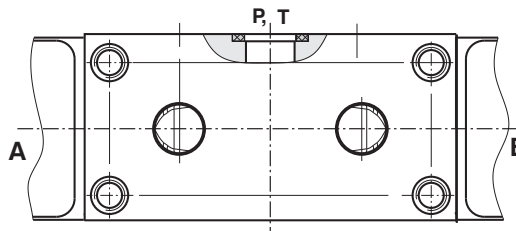

Z3 - "G" ("S")

combination of options Z1 a P1

one side inlets of channels P, T, A, B with sealing rings

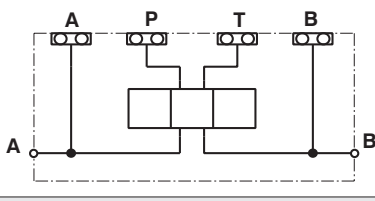
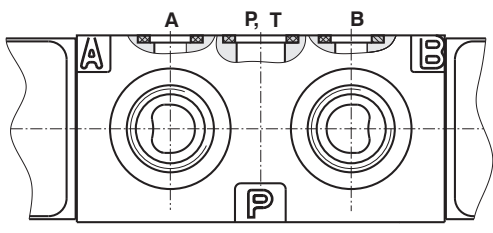

Z3 - "O"

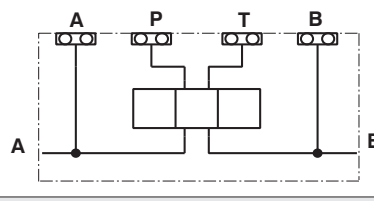
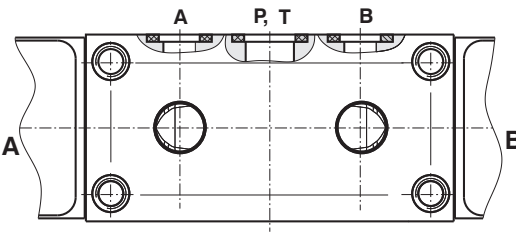

Spare Seal kit

Type	Dimensions, number			Ordering nr. Z1
	Sealing - ring	O-ring		
Standard	9,25 x 1,68 NBR 70 (2 pcs.)	16 x 2 NBR 90 (2 pcs.)		15691300
Viton	9,25 x 1,78 (2 pcs.)	16 x 2 (2 pcs.)		15691400
Type	Dimensions, number			Ordering nr. P1, Z3
	Sealing - ring	O-ring	Sealing - ring	
Standard	9,25 x 1,68 NBR 70 (2 pcs.)	16 x 2 NBR 90 (2 pcs.)	7,65 x 1,68 (2 pcs.)	28839800
Viton	9,25 x 1,78 (2 pcs.)	16 x 2 (2 pcs.)	7,65 x 1,78 (2 pcs.)	28840100

Manual Override

Dimensions in millimeters (inches)

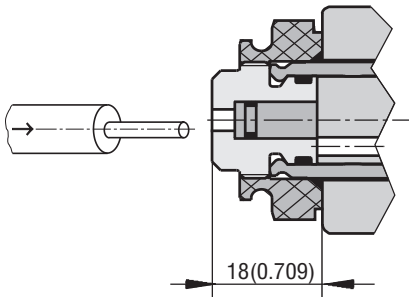
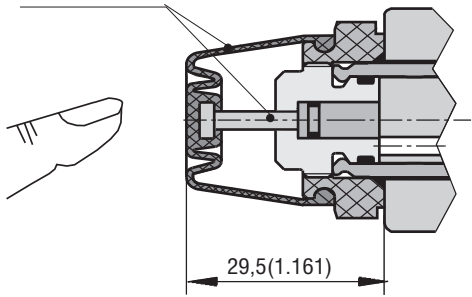
STANDARD	RUBBER BOOT		
NO DESIGNATION	N2	Ordering number / Kit	29269100
 <p data-bbox="186 629 619 689">Standard model of the manual override. Standard retaining nut of the solenoid.</p>	 <p data-bbox="873 629 1337 689">Manual override protected by rubber boot. Kit must be purchased separately.</p>		

Dimensions of Coils C14

Dimensions in millimeters (inches)

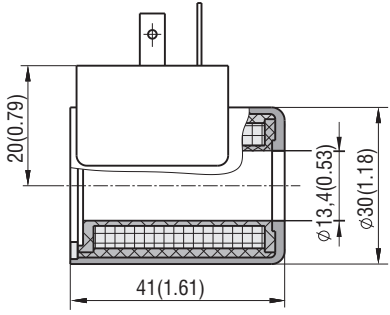
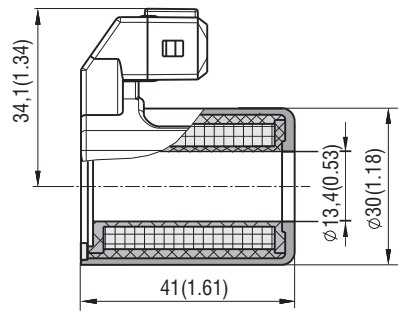
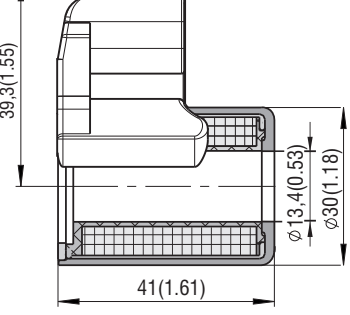
Connector design E1, E2 EN 175301-803-A Protection degree IP65	E3A, E4A AMP Junior Timer Protection degree IP65	E12, E13 Deutsch DT04-2P Protection degree IP67, IP69
		

Coils C14B			Type	Ordering number
Nominal voltage	Nominal current	Connector		
12 VDC	1,83 A	E1 - EN 175301-803-A	C14B-01200E1-6,55NA	16210300
24 VDC	0,92 A	E1 - EN 175301-803-A	C14B-02400E1-26,2NA	16210400
205 V DC*	0,08 A	E1 - EN 175301-803-A	C14B-20500E1-2476NA	16210500
12 VDC	1,83 A	E2 - E1 with quenching diode	C14B-01200E2-6,55NA	24101600
24 VDC	0,92 A	E2 - E1 with quenching diode	C14B-02400E2-26,2NA	24101800
12 VDC	1,83 A	E3A - AMP Junior Timer (2 pins; male)	C14B-01200E3A-6,55NA	28822500
24 VDC	0,92 A	E3A - AMP Junior Timer (2 pins; male)	C14B-02400E3A-26,2NA	28686400
12 VDC	1,83 A	E4A - E3A with quenching diode	C14B-01200E4A-6,55NA	28822600
24 VDC	0,92 A	E4A - E3A with quenching diode	C14B-02400E4A-26,2NA	28822400
12 VDC	1,83 A	E12 - Deutsch DT04-2P	C14B-01200E12-6,55NA	29268200
24 VDC	0,92 A	E12 - Deutsch DT04-2P	C14B-02400E12-26,2NA	29268900
12 VDC	1,83 A	E13 - E12 with quenching diode	C14B-01200E13-6,55NA	29268800
24 VDC	0,92 A	E13 - E12 with quenching diode	C14B-02400E13-26,2NA	29269000

Note:

* Coil version 205 are suitable for the rectified voltage of 230V /50Hz, Rectifier in coil included
Other designs available at request.

Block Assembly

Dimensions in millimeters

VERSION 1 - WITHOUT VALVE

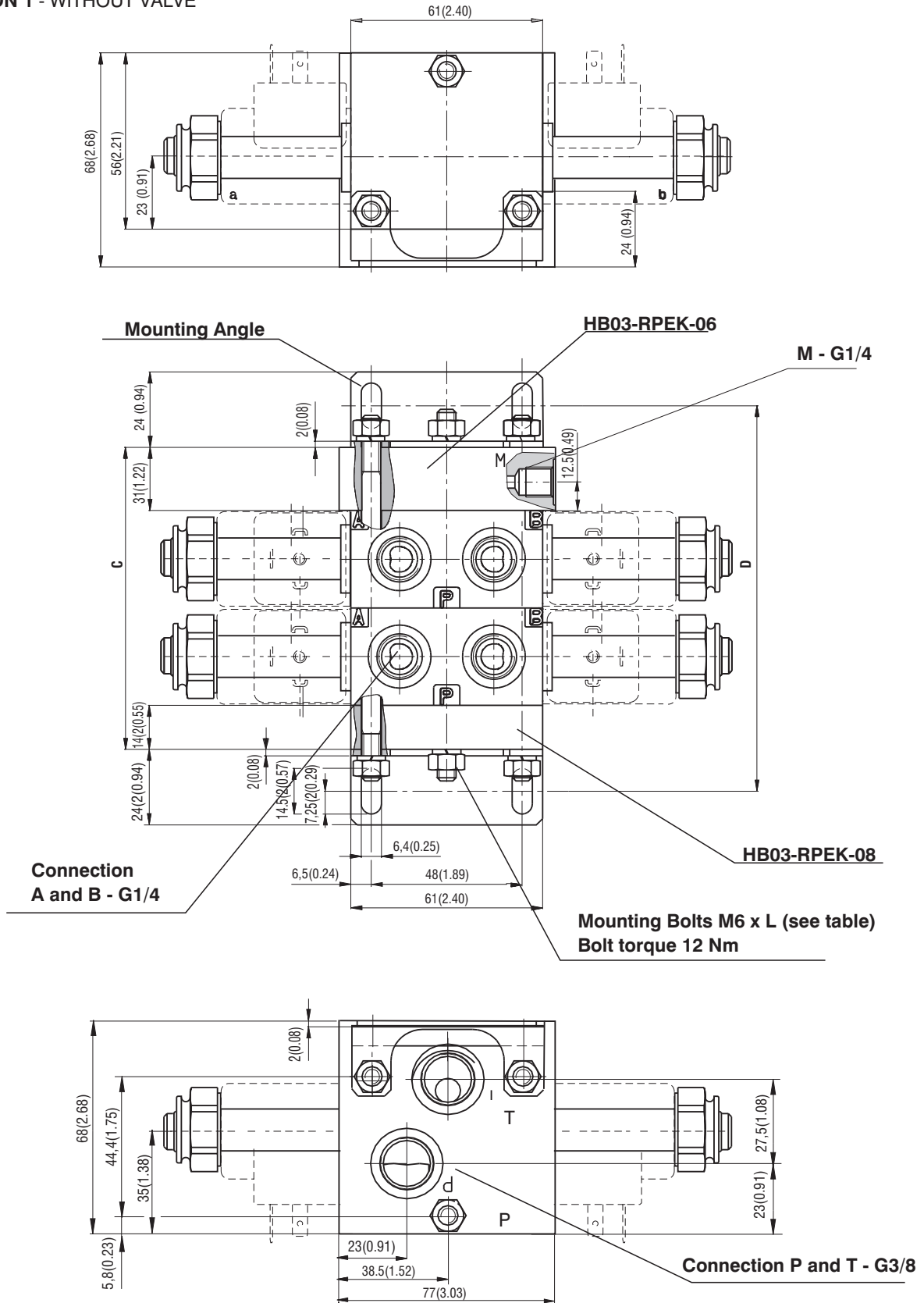

Notte:

Example of simple block assembly with two to eight distributors, feeding plate and the end plate.

Dimensions

Number of section	1	2	3	4	5	6	7	8
Dimension A [mm]	76(2.992)	107(4.212)	138(5.433)	169(6.653)	200(7.874)	231(9.094)	262(10.315)	293(11.535)
Dimension B [mm]	103(4.055)	134(5.275)	165(6.496)	196(7.716)	227(8.937)	258(10.157)	289(11.378)	320(12.598)
Dimension L [mm]	100(3.937)	133(5.236)	163(6.417)	194(7.638)	224(8.819)	256(10.079)	287(11.299)	320(12.598)

Block Assembly

Dimensions in millimeters

VERSION 2 - WITH VALVE

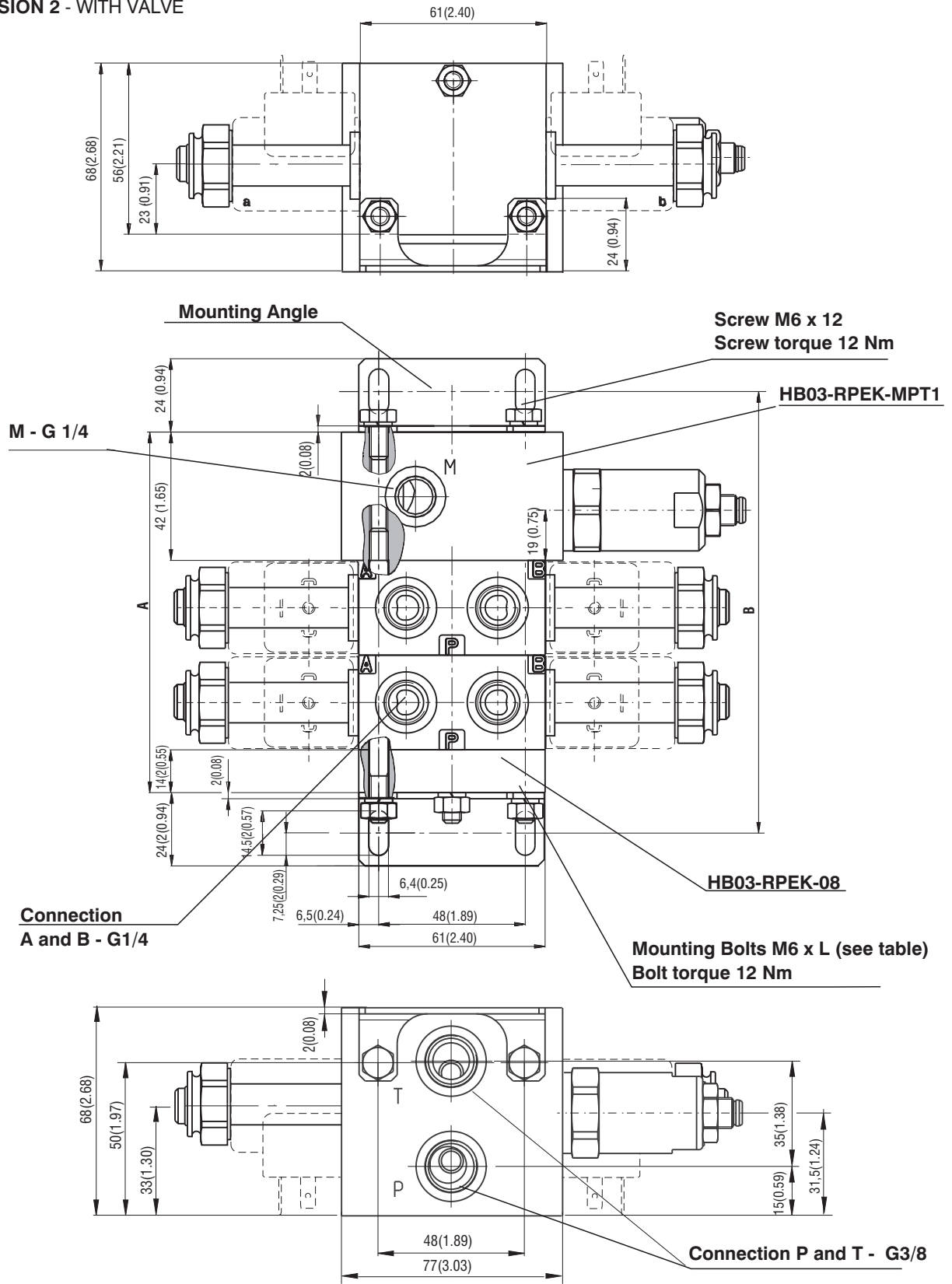

Nota:

Example of simple block assembly with two to eight distributors, feeding block with a pressure relief valve and the end plate.

Dimensions

Number of section	1	2	3	4	5	6	7	8
Dimension A [mm]	87(3.425)	118(4.646)	149(5.866)	180(7.089)	211(8.307)	242(9.527)	273(10.748)	304(11.968)
Dimension B [mm]	114(4.488)	145(5.709)	176(6.929)	207(8.150)	238(9.370)	269(10.590)	300(11.811)	331(13.031)
Dimension L [mm]	60(2.362)	100(3.937)	133(5.236)	163(6.417)	194(7.638)	224(8.819)	256(10.079)	287(11.299)

Spare Parts

- 1 Electrical connector
- 2 Solenoid coil - see coils table
- 3 Nut with seal
- 4 Seal kit

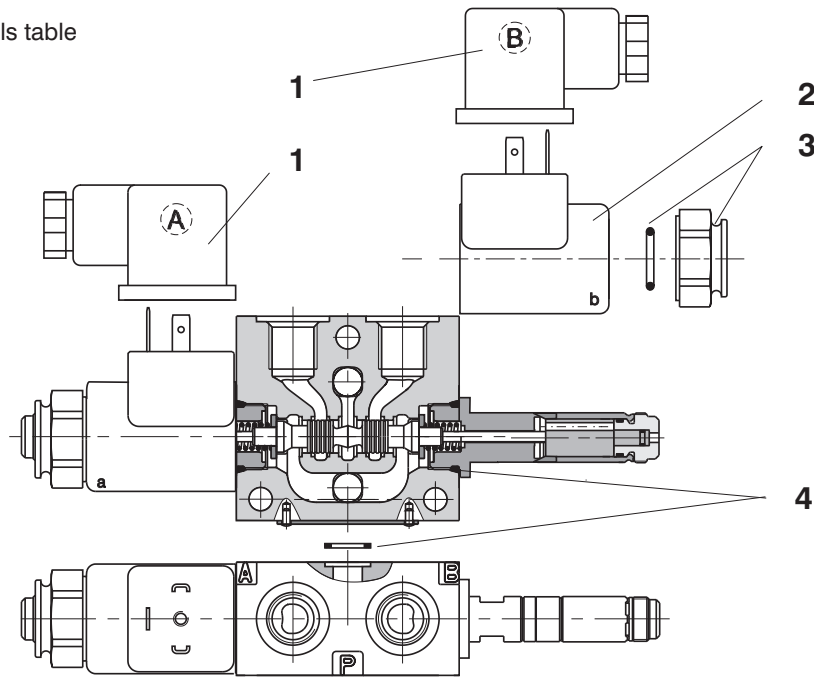

Solenoid retaining nut with seal (Kit)

Type of the nut - Mu 3 Nm(2.21lbs-ft)	Seal ring	Ordering number
Standard nut	13 x 2	15691500
Manual Override N2		29269100

Electrical connector, EN 1745301-803

Type designation	Model	Max. input voltage	Connector A grey	Connector B black
			Ordering number	
K1	without rectifier - M16x1,5 bushing bore \varnothing 6-8 mm (0.236 - 0.315 in)	230 V AC/DC	16202200	16202100
K2	without rectifier with LED and quenching diode M16x1,5 bushing bore \varnothing 6-8 mm (0.236 - 0.315 in)	12...24 V DC	16202800	16202700
K3	with rectifier - M16x1,5 bushing bore \varnothing 6-8 mm (0.236 - 0.315 in)	230 V AC	16202400	16202300
K4	with rectifier with LED and quenching diode - M16x1,5 bushing bore \varnothing 6-8 mm (0.236 - 0.315 in)	230 V AC	16203000	16202900
K5	without rectifier - M16x1,5 bushing bore \varnothing 4-6 mm (0.158 - 0.236 in)	230 V AC/DC	16202600	16202500

Mounting Angle		Tightening torque	Ordering number
Kit	Mounting Angle (1 pc.)	12 Nm (8.85lbf-ft)	28799600
	Bold M6 x 12 (2 pcs.)		
	Washer 6 (2 pcs.)		

Spare Seal kit

see side 6

Coils table C14B

see side 7

Caution

- When the distributor contains two electromagnets any of the two electromagnets can be switched on only after the other one switches off.
- Distributors with other interconnections than those shown in the catalogue can be supplied on request.
- The packaging foil can be recycled
- The transport base plate can be returned to the manufacturer.
- The mentioned data only serve to describe the product and in no case are to be understood in terms of law as guaranteed characteristics.

ARGO-HYTOS s.r.o CZ - 543 15 Vrchlábí
 tel.: 499 403111, fax: 499 403421
 e-mail: sales.cz@argo-hytos.com
 www.argo-hytos.com

- Compact modular valve system assembly
- Easy to build complex circuits
- The possibility of subsequent rebuilding or extending the valve assembly
- High variability of functional options

Functional Description

Modular assembly blocks are designed for the control of one or more hydraulic circuits, used in open hydraulic circuits. The high variability of the modular set design allows its wide use in the construction of lifting and handling equipment, machine tools and also in the field of mobile technique.

The base of the modular set is the body of the section distributor RPEK1-03. The bodies are manufactured in more several variants, which enable horizontal and vertical assembly (see RPEK1-03 directional valve data sheet HA 4027).

Channels P, T run through all horizontal sections. Inlet flow is 60 L/min nominal, sectional flow is limited with performance of RPEK directional valve 20 L/min (5.28 GPM) nominal.

Channel A, B, which run through the upper surface of the distributor body are provided with threads G1/4, or SAE6 - 9/16-18 UNF, all measuring ports are G1/4 or SAE4 - 7/16-20 UNF Unthreaded outlets on the upper or side ground surface of the body are prepared for assembly. Pressure and flow supply can be provided on the face side by a inlet P, T plate / block or in the centre of the assembled block using a central plate with radial ports of channels P, T. Furthermore, the block can be provided with a built-in pressure relief valve, which protects channel P against overloading, and the solenoid controlled valve that allows channels P-T connection thus relieving the source of the pressure fluid to tank. The supply block with the proportional distributor is used for the flow regulation in the "P" channel. Combination of 3 way pressure compensator and proportional valve allows to cave constant regulated flow independent of load.

Vertical assembly allows installation of valves into channels A, B. In vertical stacking assembly is possible to mount throttle valves, or Pilot operated check valves, and secundar pressure relief valves,

Horizontal direction blocks, plates and bodies of distributors are connected into one unit using 3 screws /

bolts and 4 bolts in the vertical direction. All connected plates are sealed.

Two fastening angles serve to mount the complete block to the base by screwing them to the face surfaces, or by using threads M6 at the bottom side of the plates and blocks.

A modular set allows horizontal assembly up to eight sections or up to sixteen sections when the centre plate is used for feeding and the blocks are grouped from both sides. It is possible to group up to four blocks vertically. In cases of more complicated block assemblies we recommend to first create a hydraulic circuit diagram.

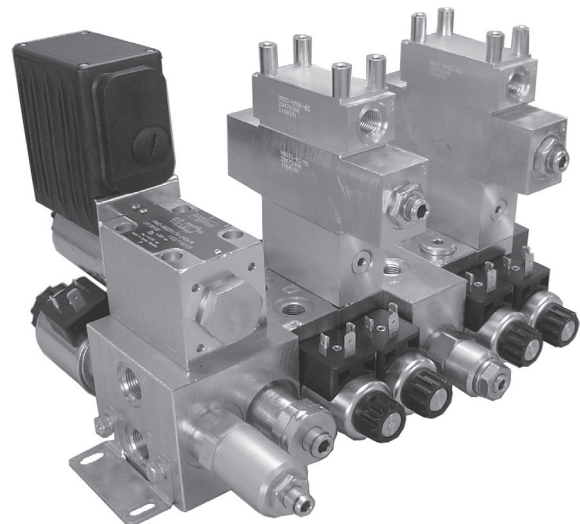

Horizontal and Vertical Assembly Illustrative Figure

1

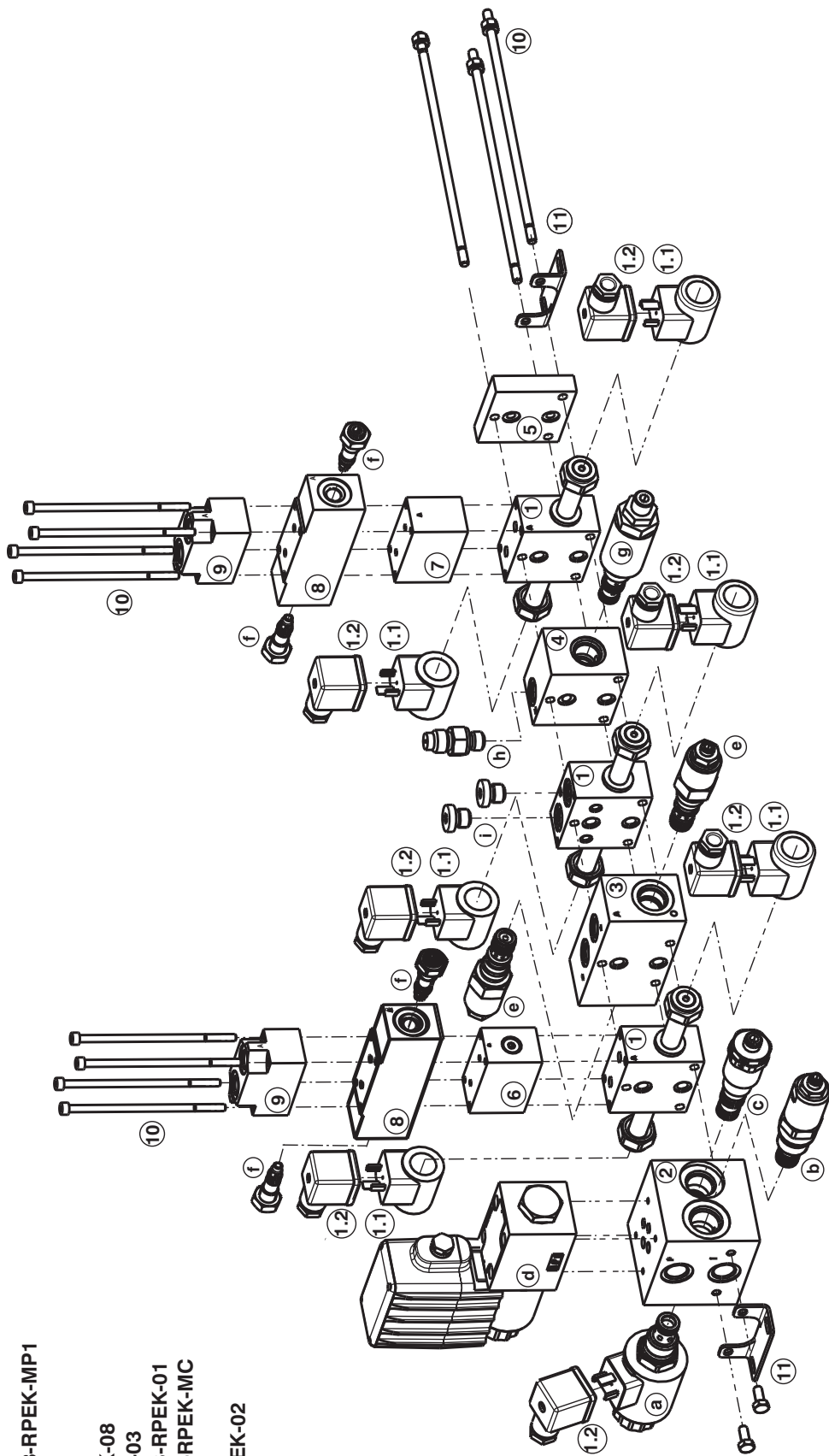
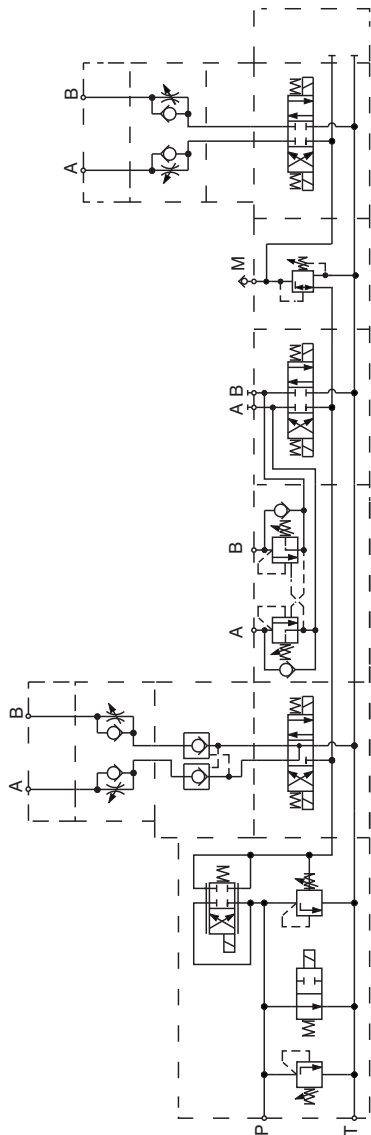

- 1. RPEK**
 - 1.1. Coils
 - 1.2. Electrical connector
 - i) Pressure plug G1/4 (SAE 6)
- 2. Inlet P, T plates HB03-RPEK-MZ**
 - a) SD2E-B2
 - b) SR1A-B2
 - c) TV2-063
 - d) PRM2-06
- 3. Sandwich plate HB03-RPEK-MAB1**
 - e) SOPA-Q3
- 4. Sandwich plate HB03-RPEK-MP1**
 - g) SP2A-A3
 - h) Minimes
- 5. End plate HB03-RPEK-08**
- 6. PO check valve VJR5-03**
- 7. Extension plate VB-03-RPEK-01**
- 8. Sandwich plate VB03-RPEK-MC**
 - f) VSV/2
- 9. Cover plate VB03-RPEK-02**
- 10. Kit studs**
- 11. Kit**

CONTENT

1. General description	1 - 3
2. Directional Control Valve RPEK1-03	4 - 11
3. Pilot Operated Check Valves for vertical assembly	12 - 14
4. Connecting threads overview	15
5. Assembly Guidelines – Horizontal Plates	16
5.1 Overview of components for horizontal assembly	16
5.2 Inlet P,T plates with valves	17 - 20
5.3 Centre P,T plates	21 - 22
5.4 Inlet P,T and End plates without valves	23 - 24
5.5 Horizontal sandwich plates with valves	25 - 31
5.6 Accessories	32 - 33
6. Assembly Guidelines – Vertical Plates	34
6.1 Overview of components for vertical assembly	34
6.2 Extension plate	35
6.3 Pilot Operated Check Valve	36
6.4 Vertical sandwich plate with valves	37 - 39
6.5 Cover plate - A,B ports	40 - 41
6.6 Measuring plate - A,B ports	42
6.7 Accessories	42

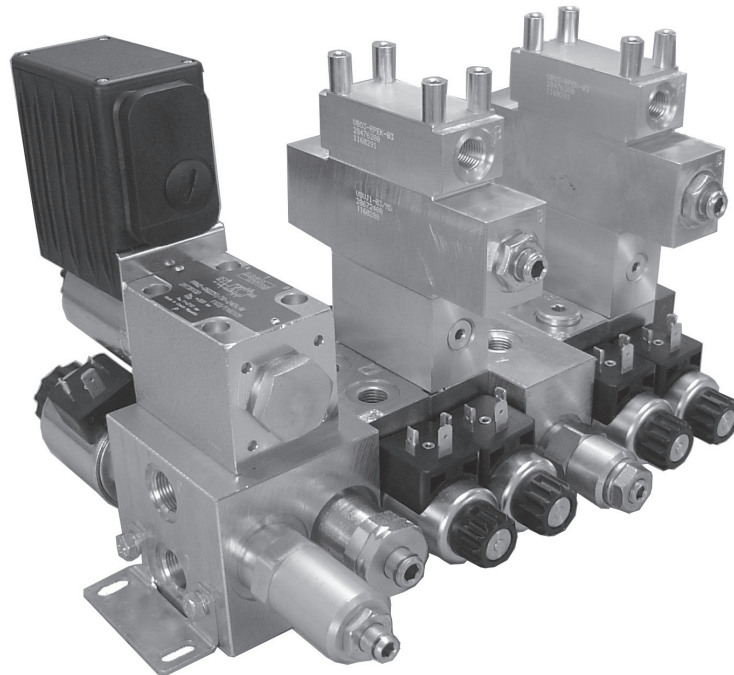

- 4/3-, 4/2 way directional control valves with solenoid control
- Solenoids can be turned around their axis to any position
- Push button manual override
- Possibility of vertical and horizontal assembly, see data sheet HA 4057

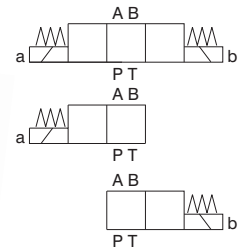

Functional Description

Distributors of the RPEK1-03 type are the basic elements for building blocks through horizontal and vertical assembly. This catalogue describes the preparation of the main unit, made up of two to eight distributors, by horizontal assembly. The distributors controlling the direction of the working fluid's flow to the individual appliances share common channels P and T. During the circuit design it is always necessary to check if the flow through the common channels covers the consumption of all appliances in all phases of the hydraulic equipment working cycle. Channels A, B outputs at the upper surface of the body are provided with threads G1/4 (type G), or SAE 9/16-18 (type S), or are prepared for vertical assembly (type O) – i.e. brought out onto a ground surface. Channels P, T, A, B outlets on the side surfaces of the body are prepared for horizontal assembly – i.e. brought out onto a ground surface or provided with The standard design of the emergency control may be additionally fitted with a pushbutton with a rubber cover. a sealing ring recess.

The individual distributor bodies are connected into a compact block using three bolts. Fastening angles serve to mount the block to the base with four screws. An assembled block feed is provided by a plate with connecting threads G3/8 in channels P, T. It is also possible to use plate with a built-in pressure relief valve to regulate the maximum pressure in the circuit.

Use data sheet No. HA 5027 to create more complex assemblies with the use of the horizontal and vertical assembly, while also using additional building elements.

The RPEK1-03 directional control valves consist of cast iron housing (1), control spool (5) with two centering springs (4) and operating solenoids (2, 3).

The three-position directional valves are fitted with two solenoids, two-position directional valves have either one solenoid.

*The operating solenoids are DC solenoids supplied through connectors A, B (6, 7). For AC supply the solenoids are provided with rectifiers, which are integrated directly into the connectors A, B (6, 7). The connectors can be turned by 90° around . By loosening the nut (8), the solenoid can be turned around its axis up to 360°.

In the case of solenoid malfunction or power failure, the spool of the valve can be repositioned by manual override (9), provided the pressure in the T-port does not exceed 25 bar. The standard design of the emergency control may be additionally fitted with a pushbutton with a rubber cover.

The basic surface treatment of the valve housing (1) is phosphate coated and the solenoids (2, 3) are zinc coated.

*Magnet coils are not included in the valve supply. The coil types selected by the customer must be ordered separately.

Type of connection "O"

Type of connection "G", "S"

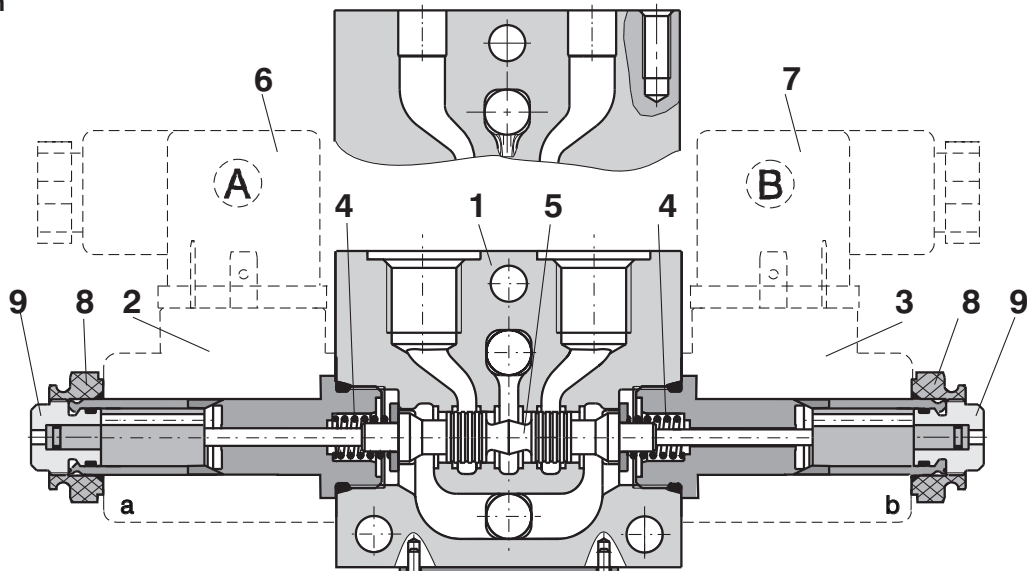

Ordering Code

RPEK1-03 /

**Solenoid Operated
Directional Control Valve**

Nominal size

Type of connection

G1/4

SAE 9/16-18

without thread

**G
S
O**

Number of valve positions

two positions

three positions

**2
3**

Functional symbols

see the table functional symbols

no designation

V

Seals

NBR

FPM (Viton)

Design form

standard

no designation

P1 through channels P, T; inlets A, B with sealing rings

Z1 one side inlets of channels P, T with sealing rings

Z3 one side inlets of channels P, T, A, B with sealing rings

Manual override *

standard

no designation

*The standard design of the manual override may be additionally fitted with a pushbutton with a rubber cover (N2).

Note: solenoid coil, electrical connector and manual override (N2) **is not supplied as mounted on**, must be ordered separately (see ordering number on page 10, 11)

Technical Data

Nominal size		03
Maximum flow	l/min (GPM)	see p-Q characteristics
Maximum operating pressure at ports P, A, B	bar (PSI)	250 (3625)
Maximum operating pressure at port T	bar (PSI)	210 (3045)
Pressure drop	bar (PSI)	see Δp -Q characteristics
Hydraulic fluid		Hydraulic oils of power classes (HL, HLP) to DIN 51 524
Fluid temperature range NBR	°C (°F)	-30 ... +80 (-22 ... +176)
Fluid temperature range FPM (Viton)	°C (°F)	-20 ... +80 (-4 ... +176)
Ambient temperature, max.	°C (°F)	up to +50 (+122)
Viscosity range	mm ² /s (SUS)	20 ... 400 (98 ... 1840)
Maximum degree of fluid contamination		Class 21/18/15 to ISO 4406 (2006)
Maximum allowable voltage variation	%	AC: ± 10 DC: ± 10
Maximum switching frequency	1/h	15 000
Switching time, ON; at $v = 32 \text{ mm}^2/\text{s}$	ms	30 ... 50
Switching time, OFF; at $v = 32 \text{ mm}^2/\text{s}$	ms	AC: 70 ... 100 DC: 30 ... 50
Duty cycle	%	100
Service life	cycles	10^7
Enclosure type to EN 60 529		see page 10
Weight - valve with 1 solenoid	kg (lb)	0.90 (1.98)
- valve with 2 solenoid		1,05 (2.32)
Mounting position		optional

Functional Symbols

Designation	Symbol	Interposition	Designation	Symbol	Interposition
Z11			R21		
C11			Y51		
H11			C51		
Y11			Z51		
R11			H11		

p-Q Characteristic

Measured at $v = 32 \text{ mm}^2/\text{s}$ (156 SUS)

Operating limits for maximum hydraulic power transferred by the directional valve.

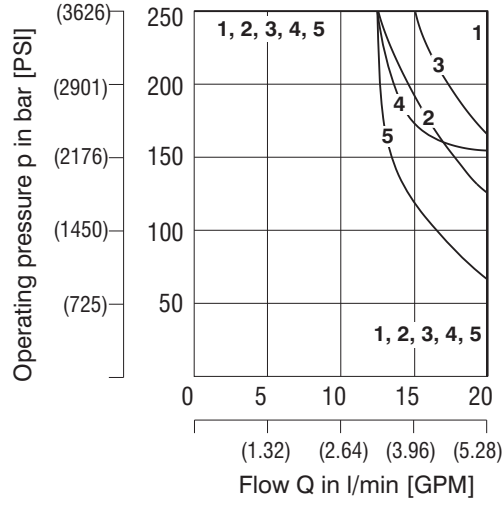

Z11	Z51	R11	R21	C11	C51	H11	Y11	Y51
1	1	1	5	2	2	3	4	4

Δp -Q Characteristic

Measured at $v = 32 \text{ mm}^2/\text{s}$ (156 SUS)

Pressure drop Δp related to flow rate.

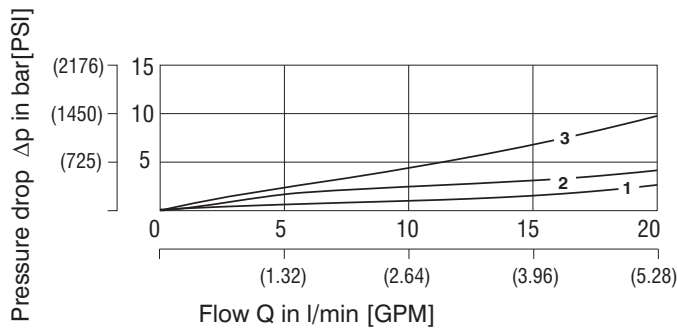

	Z11	C11	H11	Y11	R11	R21	Y51	C51	Z51
P-A	1	3	1	1	2	2		3	
P-B	1	3	1	1	2	2	1		1
A-T	1	3	1	1	2	2	1		1
B-T	1	3	1	1	2	2		3	
P-T		2	2					2	

Valve Dimensions Standard body version "G", "S"

Dimensions in millimeters (inches)

	G	S
THREAD	G1/4	SAE6 - 9/16-18UNF
ØD [mm]	Ø20,9H13	Ø 25 ^{+0,5}
ØD [in]	0.823	0.984 ^{+0.020}
A [mm (in)]	1 (0.039)	0,5 (0.020)

Valve with two solenoids

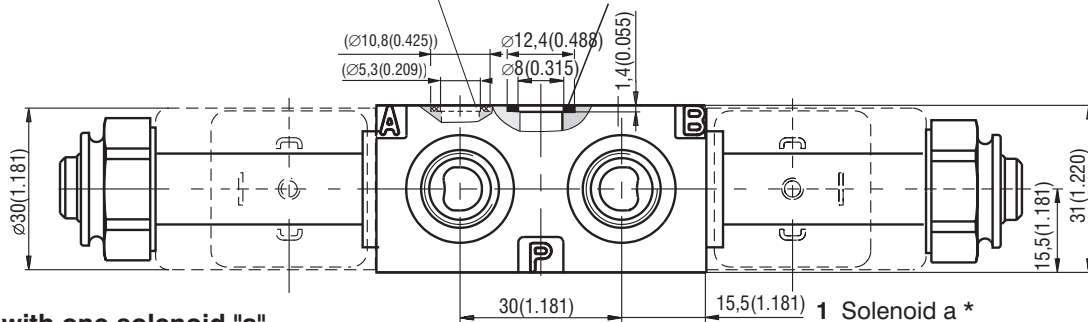
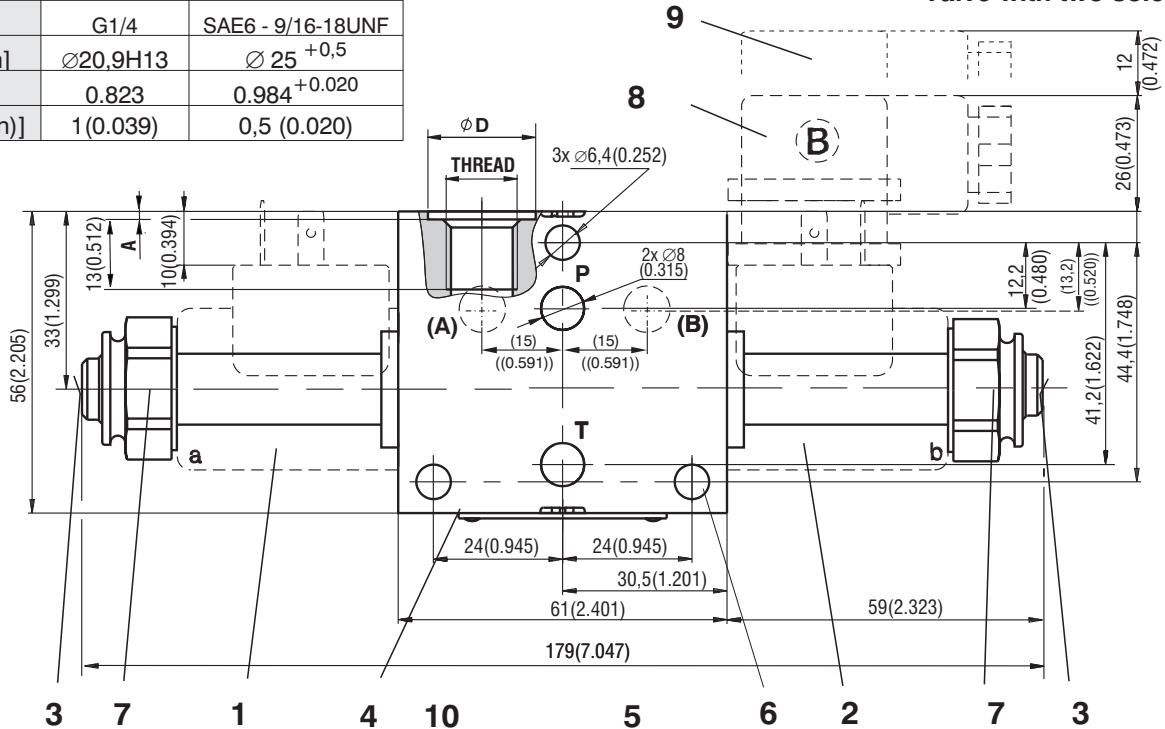

Valve with one solenoid "a"

Functional symbols R11, R21, Y51, C51, Z51

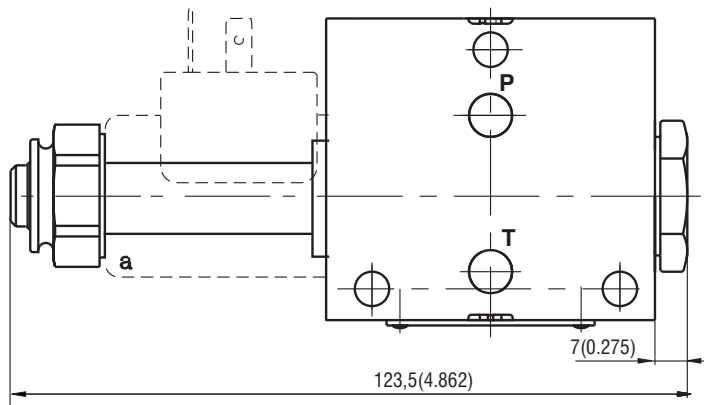

Valve with one solenoid "b"

Functional symbols H11

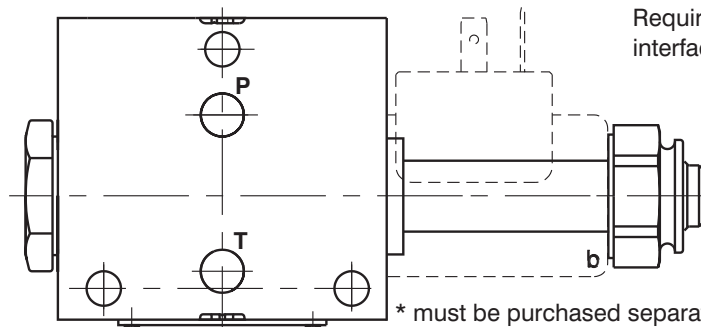

- 1 Solenoid a *
- 2 Solenoid b *
- 3 Manual override
- 4 Name plate
- 5 Square ring 9,25 x 1,68 (2 ks.) supplied with valve
- 6 3 mounting holes
- 7 Retaining nut of the solenoid
- 8 Electrical connector, EN 1745301-803
- 9 Space required to remove connector
- 10 Outlets A/B are only at the versions P1, Z1; Z3, Seal 7,65x1,68

* must be purchased separately (see page 7)

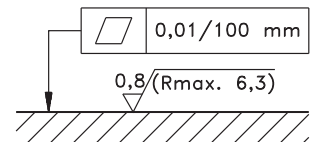

Required surface finish of interface

* must be purchased separately (see page 7)

Valve Dimensions Standard body version "O"

Dimensions in millimeters (inches)

Valve with two solenoids

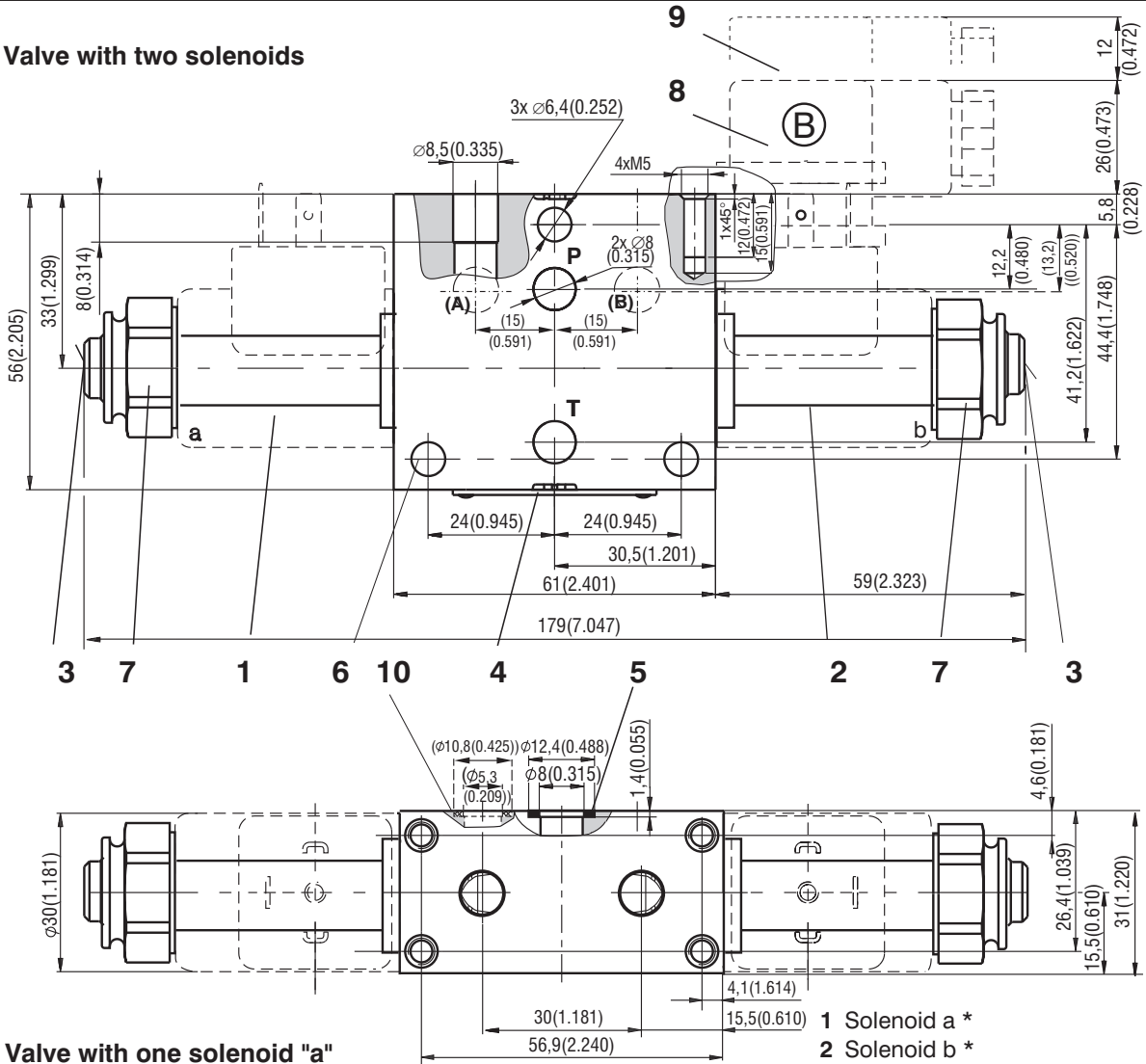

Valve with one solenoid "a"

Functional symbols R11, R21, Y51, C51, Z51

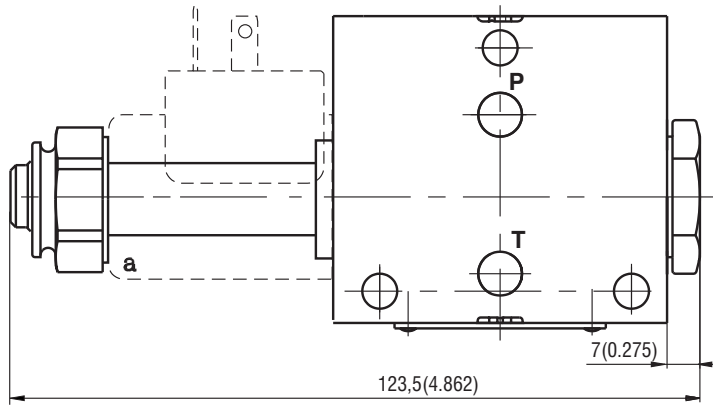

- 1 Solenoid a *
- 2 Solenoid b *
- 3 Manual override
- 4 Name plate
- 5 Square ring 9,25 x 1,68 (2 ks.) supplied with valve
- 6 3 mounting holes
- 7 Retaining nut of the solenoid
- 8 Electrical connector, EN 1745301-803
- 9 Space required to remove connector
- 10 Outlets A/B are only at the versions P1, Z3, Seal 7,65x1,68

* must be purchased separately (see page 7)

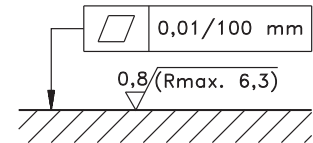

Required surface finish of interface

Valve with one solenoid "b"

Functional symbols H11

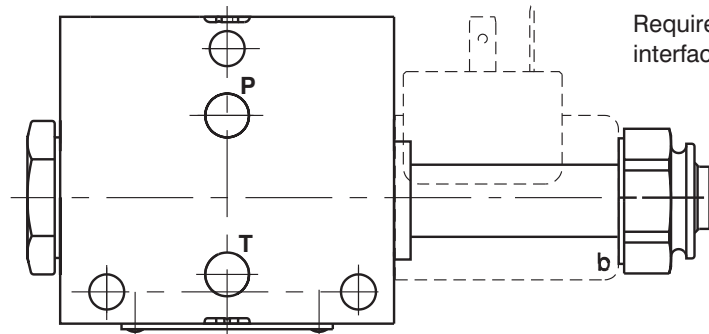

Design form "G" ("S"), "O"

P1 - "G" ("S")

through channels P, T; outlets A, B with sealing rings

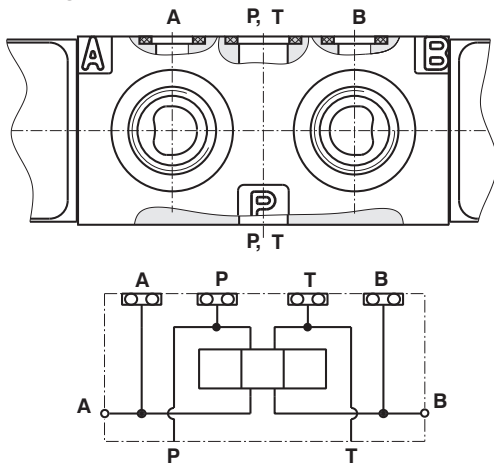

P1 - "O"

4xM5
for vertical assembly

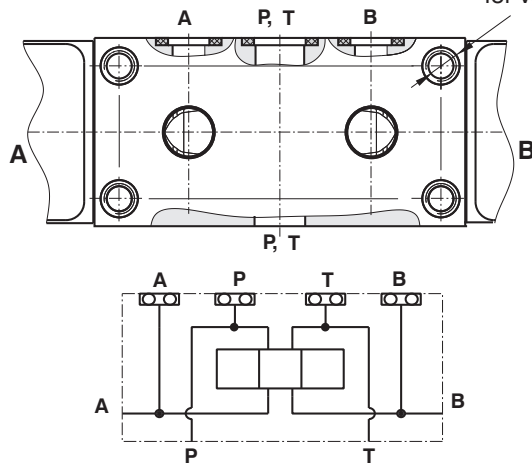

Z1 - "G" ("S")

one side inlets of channels P, T with sealing rings (outlets A, B only on the upper surface)

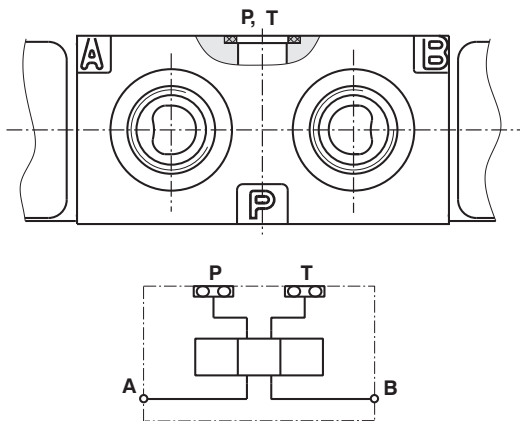

Z1 - "O"

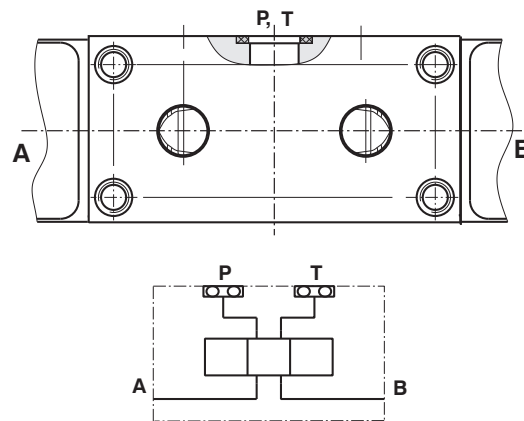

Z3 - "G" ("S")

combination of options Z1 a P1

one side inlets of channels P, T, A, B with sealing rings

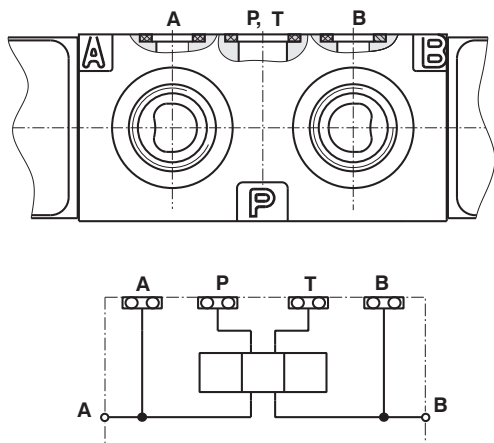

Z3 - "O"

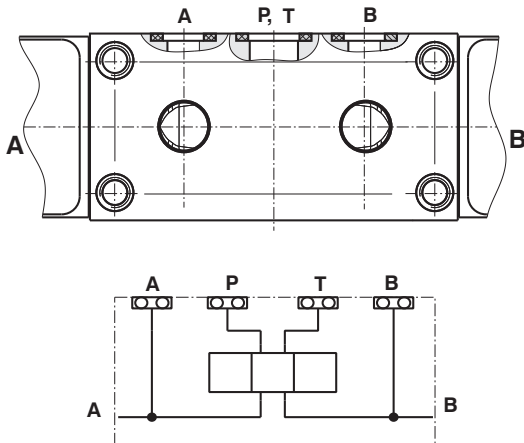

Spare Seal kit

Type	Dimensions, number			Ordering nr. Z1
	Sealing - ring	O-ring		
Standard	9,25 x 1,68 NBR 70 (2 ks.)	16 x 2 NBR 90 (2ks.)		15691300
Type	Dimensions, number			Ordering nr. P1, Z3
	Sealing - ring	O-ring	Sealing - ring	
Standard	9,25 x 1,68 NBR 70 (2 ks.)	16 x 2 NBR 90 (2 ks.)	7,65 x 1,68 (2 pcs.)	28839800
Viton	9,25 x 1,78 (2 pcs.)	16 x 2 (2 pcs.)	7,65 x 1,78 (2 pcs.)	28840100

Manual Override

Dimensions in millimeters (inches)

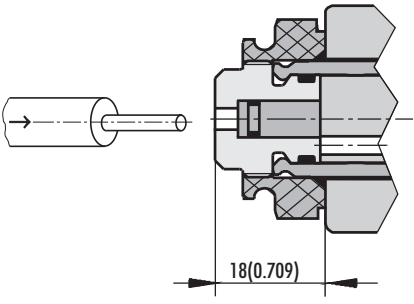
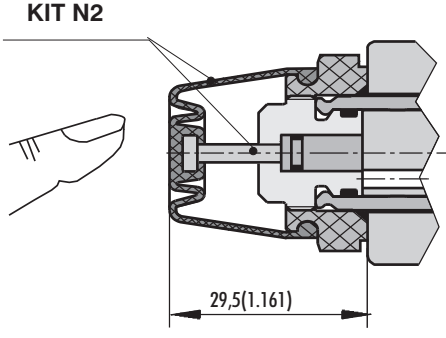
STANDARD		RUBBER BOOT	
NO DESIGNATION	N2	Ordering number / Kit	29269100
 <p>Standard model of the manual override. Standard retaining nut of the solenoid.</p>		 <p>KIT N2</p> <p>Manual override protected by rubber boot. Kit must be purchased separately.</p>	

Dimensions of Coils C14

Dimensions in millimeters (inches)

Connector design

E1, E2

EN 175301-803-A

Protection degree IP65

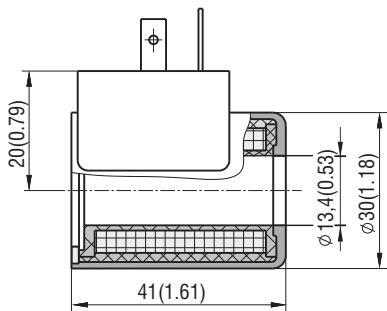

E3A, E4A

AMP Junior Timer

Protection degree IP65

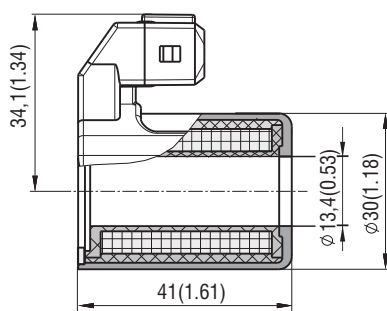

E12, E13

Deutsch DT04-2P

Protection degree IP67, IP69

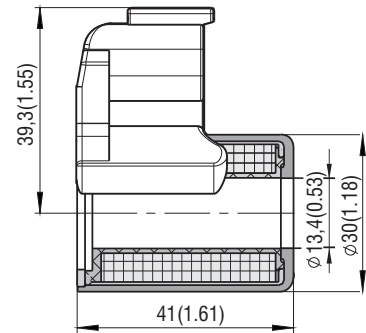

Coils C14B

Nominal voltage	Nominal current	Connector	Type code	Ordering number
12 VDC	1,83 A	E1 - EN 175301-803-A	C14B-01200E1-6,55NA	16210300
24 VDC	0,92 A	E1 - EN 175301-803-A	C14B-02400E1-26,2NA	16210400
205 V DC*	0,08 A	E1 - EN 175301-803-A	C14B-20500E1-2476NA	16210500
12 VDC	1,83 A	E2 - E1 with quenching diode	C14B-01200E2-6,55NA	24101600
24 VDC	0,92 A	E2 - E1 with quenching diode	C14B-02400E2-26,2NA	24101800
12 VDC	1,83 A	E3A - AMP Junior Timer (2 pins; male)	C14B-01200E3A-6,55NA	28822500
24 VDC	0,92 A	E3A - AMP Junior Timer (2 pins; male)	C14B-02400E3A-26,2NA	28686400
12 VDC	1,83 A	E4A - E3A se zhašecí diodou	C14B-01200E4A-6,55NA	28822600
24 VDC	0,92 A	E4A - E3A se zhašecí diodou	C14B-02400E4A-26,2NA	28822400
12 VDC	1,83 A	E12 - Deutsch DT04-2P	C14B-01200E12-6,55NA	29268200
24 VDC	0,92 A	E12 - Deutsch DT04-2P	C14B-02400E12-26,2NA	29268900
12 VDC	1,83 A	E13 - E12 se zhašecí diodou	C14B-01200E13-6,55NA	29268800
24 VDC	0,92 A	E13 - E12 se zhašecí diodou	C14B-02400E13-26,2NA	29269000

Note:

* Coil version 205 are suitable for the rectified voltage of 230V /50Hz, Rectifier in coil included
Other designs available at request.

Spare Parts

- 1 Electrical connector
- 2 Solenoid coil - see coils table
- 3 Nut with seal
- 4 Seal kit

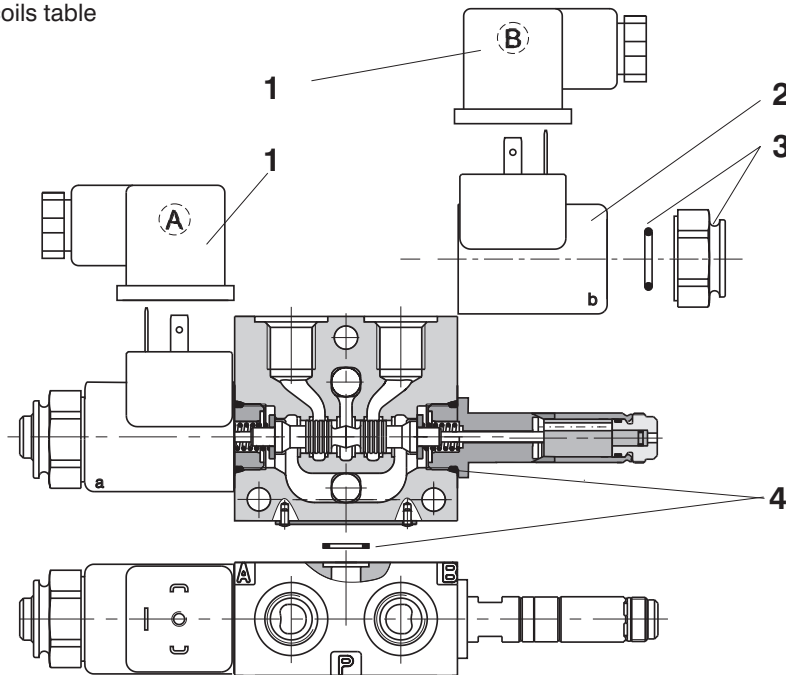

Solenoid retaining nut with seal

Type of the nut - Mu 3 Nm(2.21lbs-ft)	Seal ring	Ordering number
Standard nut	13 x 2	15691500
Manual Override N2		29269100

Electrical connector, EN 1745301-803

Type designation	Model	Max. input voltage	Connector A grey	Connector B black
			Ordering number	
K1	without rectifier - M16x1,5 bushing bore \varnothing 6-8 mm (0.236 - 0.315 in)	230 V AC/DC	16202200	16202100
K2	without rectifier with LED and quenching diode M16x1,5 bushing bore \varnothing 6-8 mm (0.236 - 0.315 in)	12...24 V DC	16202800	16202700
K3	with rectifier - M16x1,5 bushing bore \varnothing 6-8 mm (0.236 - 0.315 in)	230 V AC	16202400	16202300
K4	with rectifier with LED and quenching diode - M16x1,5 bushing bore \varnothing 6-8 mm (0.236 - 0.315 in)	230 V AC	16203000	16202900
K5	without rectifier - M16x1,5 bushing bore \varnothing 4-6 mm (0.158 - 0.236 in)	230 V AC/DC	16202600	16202500

Caution

- When the distributor contains two electromagnets any of the two electromagnets can be switched on only after the other one switches off.
- Distributors with other interconnections than those shown in the catalogue can be supplied on request.
- The packaging foil can be recycled
- The transport base plate can be returned to the manufacturer.
- The mentioned data only serve to describe the product and in no case are to be understood in terms of law as guaranteed characteristics.

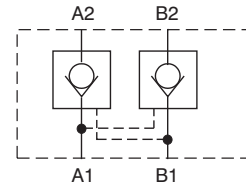
Size 03 • p_{max} up to 250 bar (3625 PSI) • Q_{max} up to 20 l/min (5.28 GPM)

- Sandwich plate design for use in vertical stacking assemblies
- 3 models:
 - leakfree closure of both sides with check valves in lines A and B
 - leakfree closure with check valve in line A
 - leakfree closure in line B

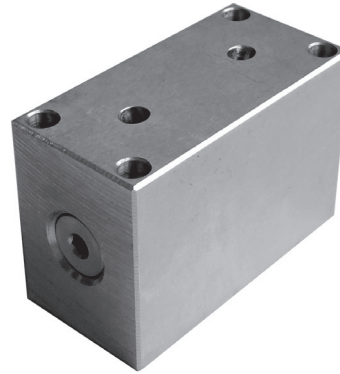

Functional Description

A hydraulic lock serves to close tightly a hydraulic circuit under pressure. It provides a load against a pressure drop and secures a stable position of piston of the cylinder under pressure also for a longer period.

The valve consist of an aluminium body (1), one or two check valves (2), (3) and a control piston (4).

If a fluid is flowing in the direction from A1 (B1) into A2 (B2), a ball lifts (2) or (3), and the control piston (4) shifts at the same time to the right (left) and pushes out the ball (3) or (2) from the seat. This releases the connection B2 → B1 (A2 → A1). If the pressure drops in channels A1

and B1 (e.g. when the distributor shifts to the centre position), the spring presses the ball springs (2) and (3) into the seats and the cylinder circuit is closed under pressure.

To ensure a tight seal of the spaces A2 and B2, the distributor with Y interconnection must be used, which, when in the centre position, connects both sides of the control piston (4) with the tank.

Without surface finish.

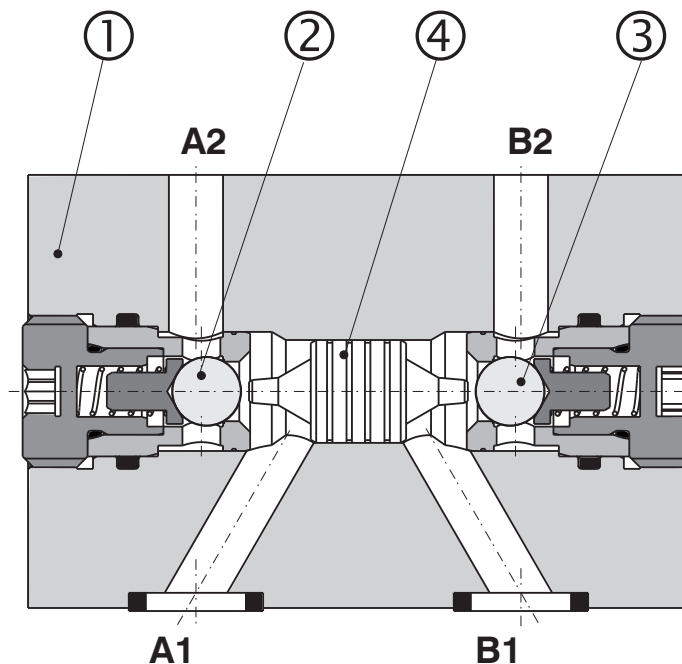

Ordering Code

VJR5-03/M
**Pilot Operated Check Valve
Sandwich Plate**
Nominal size
Modular design
**no designation
V**
Seals
NBR
FPM (Viton)

**A
B
C**
Functional Symbols
check valve in line A*
check valve in line B*
check valves in lines A and B*
* see the table Functional symbols

Functional Symbols

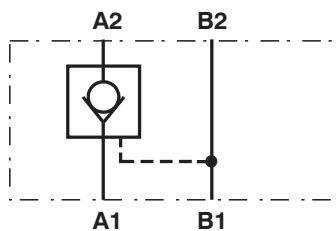
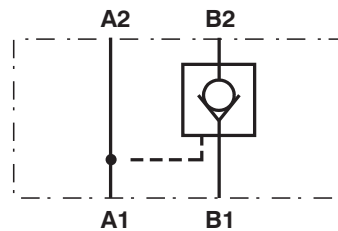
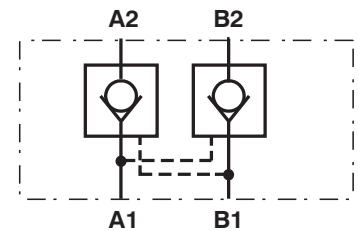
Arrangement of the check valves in the valve body
VJR5-03/MA

VJR5-03/MB

VJR5-03/MC

Technical Data

Nominal size		03
Maximum flow	L/min (GPM)	20 (5.28)
Maximum operating pressure	bar (PSI)	250 (3625)
Cracking pressure	bar (PSI)	0,25 (3.625)
Hydraulic fluid		Hydraulic oils of power classes (HL, HLP) to DIN 51524
Fluid temperature range (NBR)	°C (°F)	-30 ... +80 (-22 ... +176)
Fluid temperature range (Viton)	°C (°F)	-20 ... +80 (-4 ... +176)
Viscosity range	mm ² /s	20 ... 400 (98 ... 1840)
Maximum degree of fluid contamination		Class 21/18/15 to ISO 4406 (2006)
Area ratio (pilot piston / poppet)		3 : 1
Mounting position		optional
Weight	kg (lb)	0,2 (0.44)

Δp-Q Characteristics

Measured at $v = 32 \text{ mm}^2/\text{s}$ (156 SUS)

Pressure drop Δp related to flow rate.
 Pressure loss with distributor **RPEK1-033/Y11**

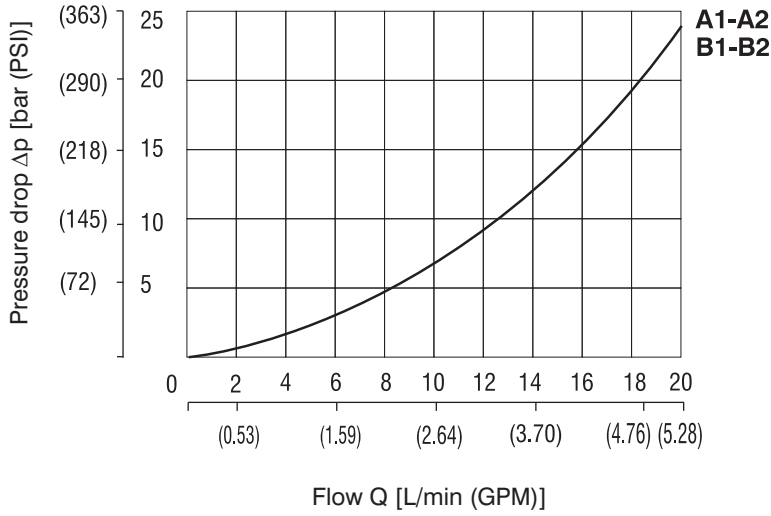

Flow in direction	
1	A1 → A2 (B1 → B2)
2	A2 → A1 (B2 → B1)

Valve Dimensions

Dimensions in millimeters (inches)

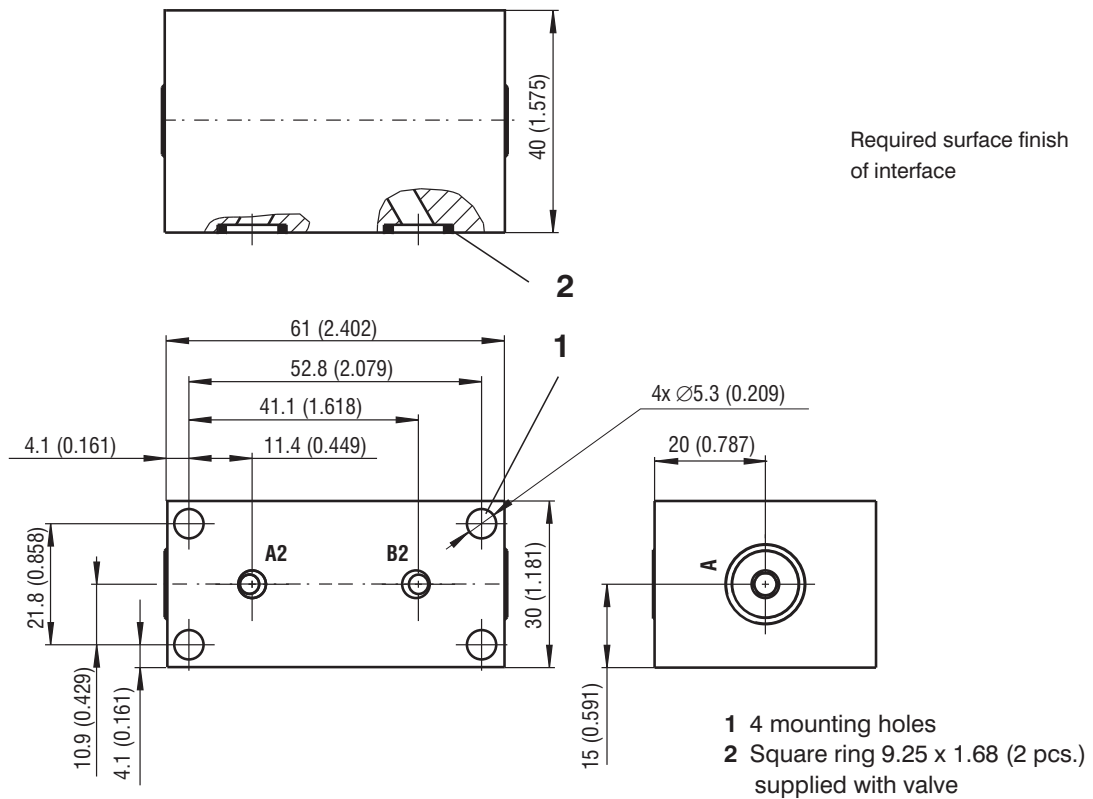

Spare Parts

Seal kit

Type	Dimensions, quantity		Ordering number
	Square ring	O-ring	
Standard NBR70	9,25 x 1,68 (2 pcs.)	4,47 x 1,78 (2 pcs.)	28407200
Viton	-	9,25 x 1,78 (2 pcs.)	28407300
		4,47 x 1,78 (2 pcs.)	

Threaded Chambers for the RPEK Kit Connecting

INLET/OUTLET PORTS FOR HORIZONTAL AND VERTICAL ASSEMBLY

G3/8 P, T

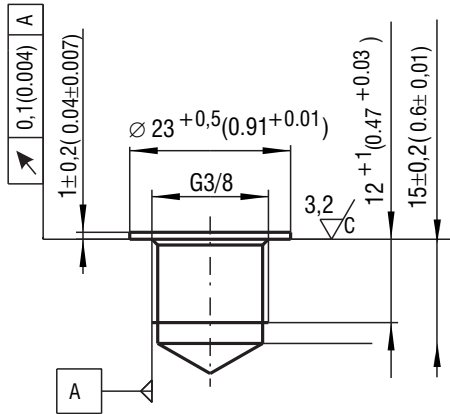

G1/4 M, A, B

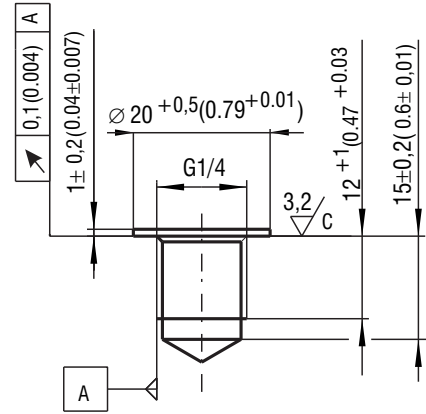

SAE8 - 3/4-16 UNF P, T

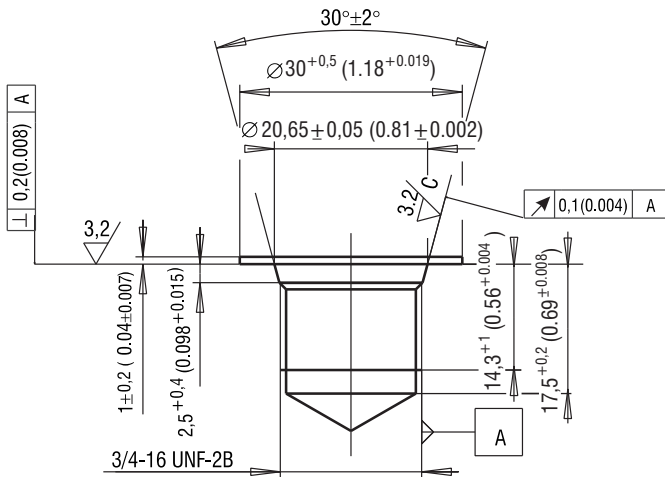

SAE6 - 9/16-18 UNF A, B

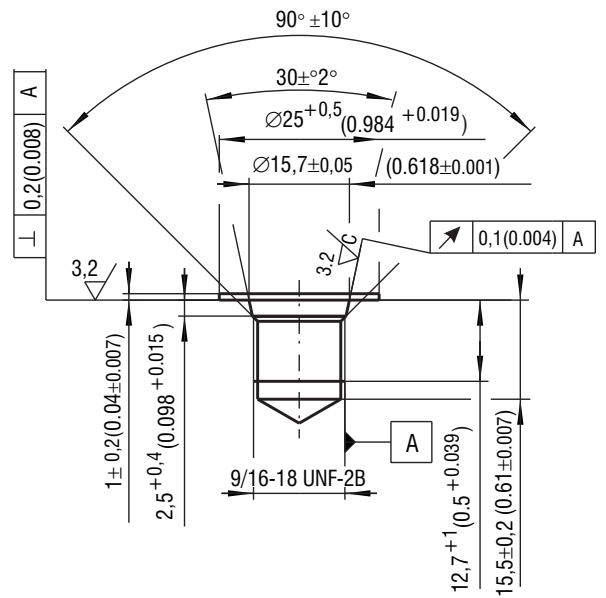

G1/2 P, T

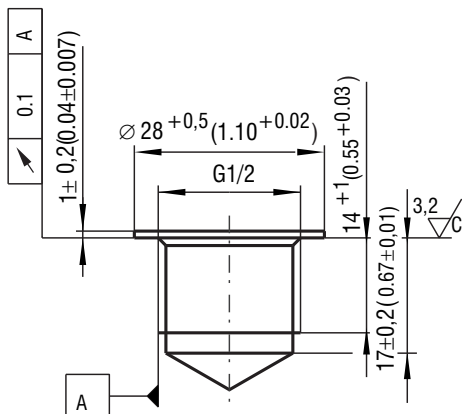

SAE4 - 7/8-14 UNF M

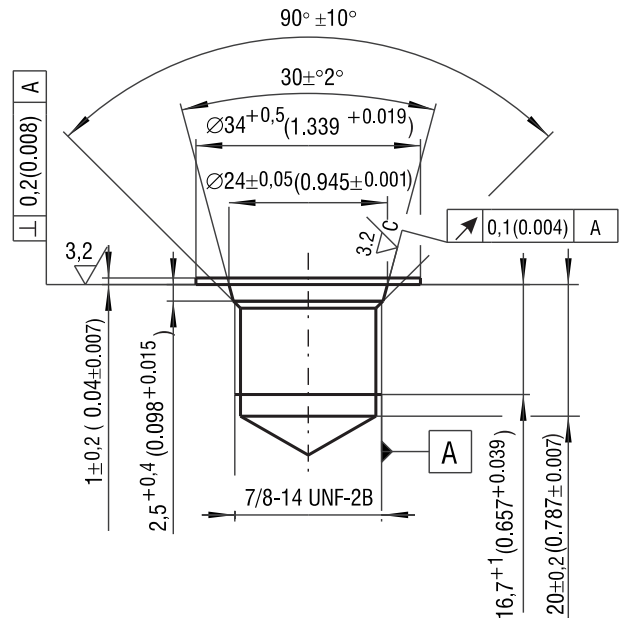

HORIZONTAL ASSEMBLY PLATES

1- 8 sections (up to 16 sections – when using centre feeding plate with bolt threads from both sides)

Complete valves in modular configuration

Type	Cavity	Connecting threads	Ordering number	Page	Description (to select the studs)
RPEK1-03	Dn03	Data sheet HA 4027		4-13	L2=31 mm (1.22 in)

Inlet P,T Plates with Valves

HB03-RPEK-MPT	2/2 - 7/8-14UNF	G 3/8 - P, T, G 1/4 - M	28566200	17	---
HB03-RPEK-MPT-S	2/2 - 7/8-14UNF	SAE 8 - P, T, SAE 4 - M	29342200	17	---
HB03-RPEK-MPT1	2/2 - 7/8-14UNF	G 3/8 - P, T, G 1/4 - M	28813600	18	---
HB03-RPEK-MPT1-S	2/2 - 7/8-14UNF	SAE 8 - P, T, SAE 4 - M	29342300	18	---
HB03-RPEK-MPT2	2/2 - 7/8-14UNF	G 1/2 - P, T, G 1/4 - M	29401100	19	---
HB03-RPEK-MZ	2/2 - 7/8-14UNF	G 3/8 - P, T	28566300	20	---
HB03-RPEK-MZ-S	2/2 - 7/8-14UNF	SAE 8 - P, T	29342400	20	---

Centre P,T Plates

Bolt threads from both sides					
HB03-RPEK-01		G 3/8 - P, T,	28659800	21	---
HB03-RPEK-01-S		SAE 8 - P, T	29344600	21	---
HB03-RPEK-02		G 3/8 - P, T, G 1/4 - M	28659900	21	---
HB03-RPEK-02-S		SAE 8 - P, T, SAE 4 - M	29344700	21	---
Straight-through holes for bolts					
HB03-RPEK-03		G 3/8 - P, T	28660000	22	L2=31 mm (1.22 in)
HB03-RPEK-03-S		SAE 8 - P, T	29344800	22	L2=31 mm (1.22 in)
HB03-RPEK-04		G 3/8 - P, T, G 1/4 - M	28660100	22	L2=31 mm (1.22 in)
HB03-RPEK-04-S		SAE 8 - P, T, SAE 4 - M	29344900	22	L2=31 mm (1.22 in)

Inlet P,T and End Plates without Valves

Without recess for sealing rings					
HB03-RPEK-05			16786901	23	L3=14 mm (0.55 in)
HB03-RPEK-06		G 3/8 - P, T, G 1/4 - M	28566800	23	L2=31 mm (1.22 in)
HB03-RPEK-06-S		SAE 8 - P, T, SAE 4 - M	29343300	23	L2=31 mm (1.22 in)
With sealing rings' recess					
HB03-RPEK-07		G 3/8 - P, T, G 1/4 - M	28660200	24	L2=31 mm (1.22 in)
HB03-RPEK-07-S		SAE 8 - P, T, SAE 4 - M	29345000	24	L2=31 mm (1.22 in)
HB03-RPEK-08			28660300	24	L3=14 mm (0.55 in)

Horizontal Sandwich Plates with Valves

HB03-RPEK-MP1	3/2 - 3/4-16UNF	G 1/4 - M	28658500	25	L1=40 mm (1.57 in)
HB03-RPEK-MP1-S	3/2 - 3/4-16UNF	SAE 4 - M	29344000	25	L1=40 mm (1.57 in)
HB03-RPEK-MP2	3/2 - 3/4-16UNF	G 1/4 - M	28658900	26	L1=40 mm (1.57 in)
HB03-RPEK-MP2-S	3/2 - 3/4-16UNF	SAE 4 - M	29344100	26	L1=40 mm (1.57 in)
HB03-RPEK-MC	2/2 - 3/4-16UNF		28659200	27	L1=40 mm (1.57 in)
HB03-RPEK-MD	2/2 - 3/4-16UNF		28659400	28	L1=40 mm (1.57 in)
HB03-RPEK-MAB	2/2 - 3/4-16UNF	G 1/4 - A, B	28659700	29	L1=40 mm (1.57 in)
HB03-RPEK-MAB-S	2/2 - 3/4-16UNF	SAE 6 - A, B	29344200	29	L1=40 mm (1.57 in)
HB03-RPEK-MAB1	M20x1,5	G 1/4 - A, B	28650700	30	L1=40 mm (1.57 in)
HB03-RPEK-MAB1-S	M20x1,5	SAE 6 - A, B	29344500	30	L1=40 mm (1.57 in)
HB03-RPEK-MAB2	2/2 - 3/4-16UNF		29397800	31	L1=40 mm (1.57 in)

Other possible assembly parts - for connecting material see pages 32, 33.

- A pressure plug **15625300** can be ordered measuring outlet and off the **A, B - G1/4** valve outlet.
- A pressure plug **20400400** can be ordered measuring outlet and off the **A, B - SAE 6** valve outlet.
- A pressure plug **20399400** can be ordered to blank off the **M - SAE 4**.

Inlet Palette

HB03-RPEK-MPT/- (S)

28566200/(29342200)

1

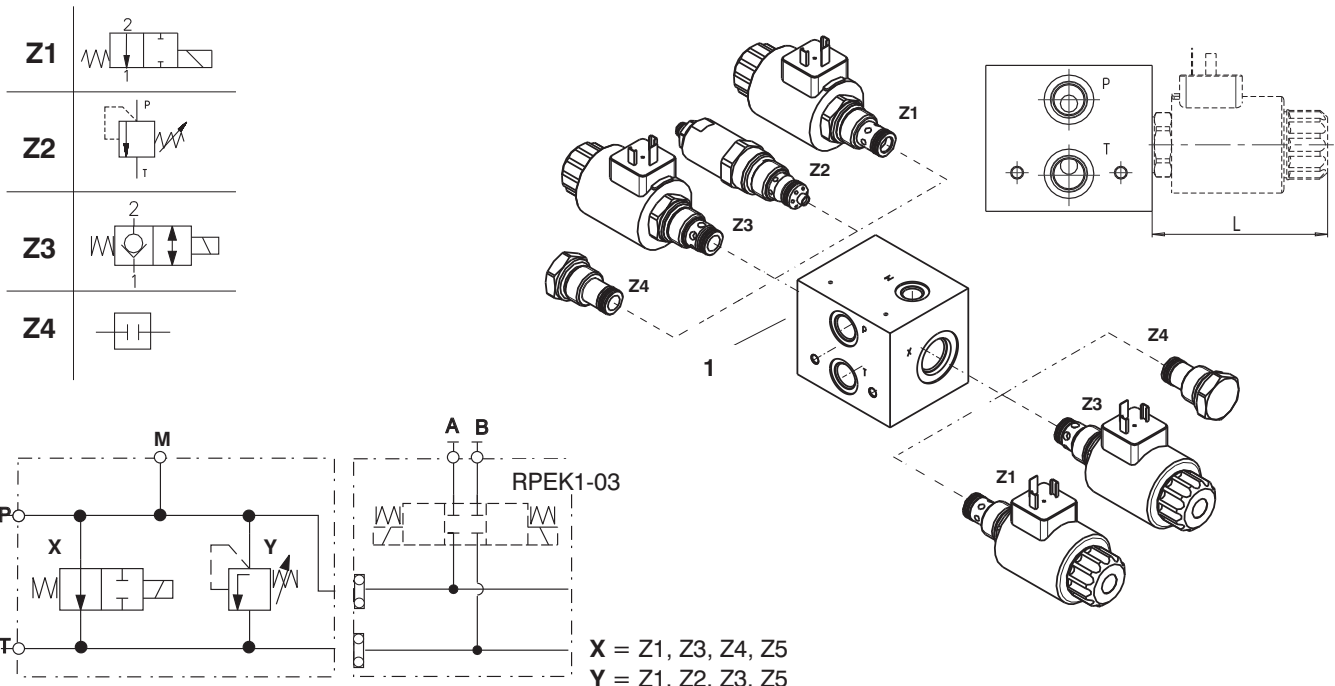

Pos.	Name	Type	Max. L [mm (in)]	Weight [kg (lb)]	Data sheet	Ordering number
1	Inlet Palette	HB03-RPEK-MPT		0,813(1.79)		28566200
		HB03-RPEK-MPT-S				29342200
Z1	Directional valve	SD2E-B2	82 (3.23)		HA 4060	
Z2	Pressure valve	SR1A-B2	65 (2.56)		HA 5064	
Z3	Directional valve	SD3E-B2	82 (3.23)		HA 4063	
Z4	Check valve	SC1F-B2	28 (1.10)		HA 5017	
Z5	Plug 2/2-7/8-14UNF		10 (0.39)			19356300

Valve Dimensions - MPT/- (S)

Dimensions in millimeters (inches)

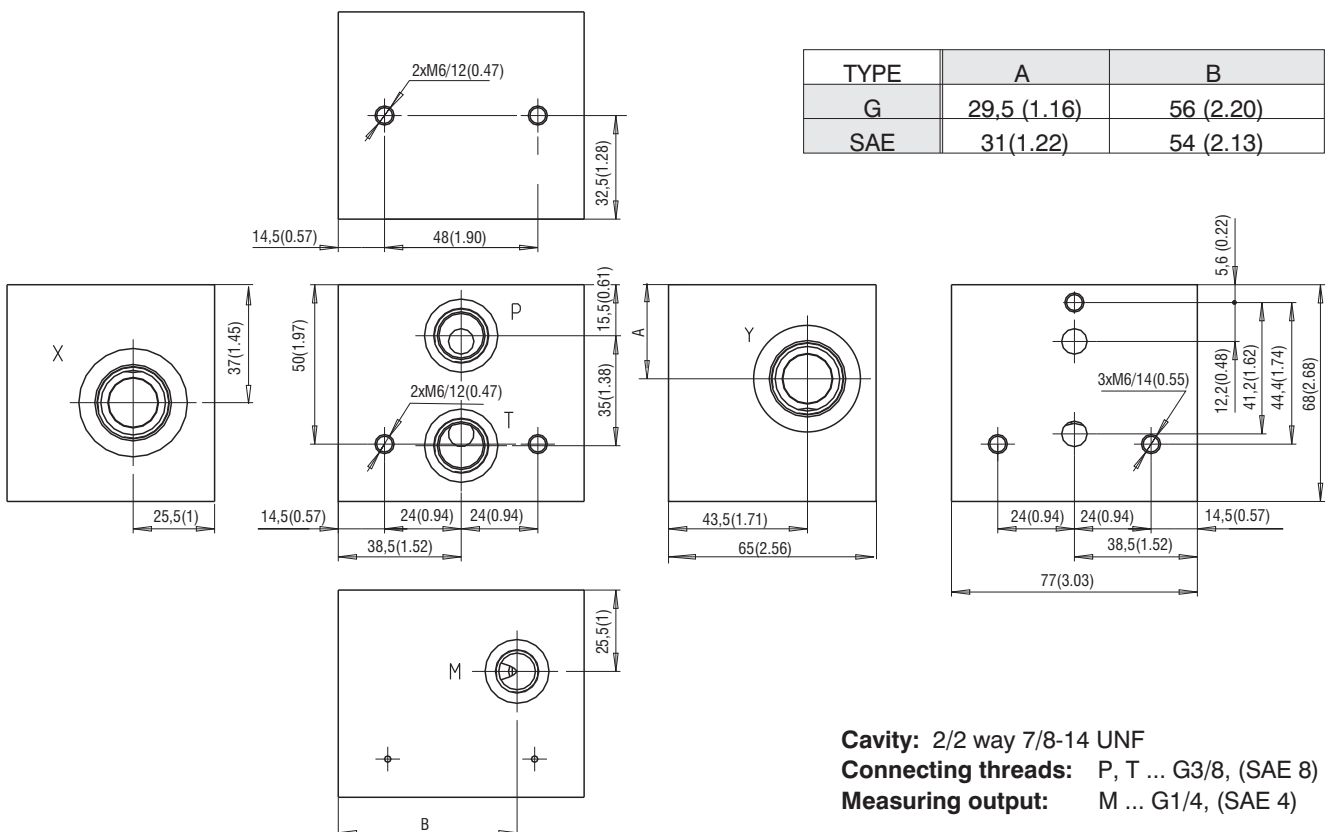

Inlet Palate

HB03-RPEK-MPT1/- (S)

28813600/(29342300)

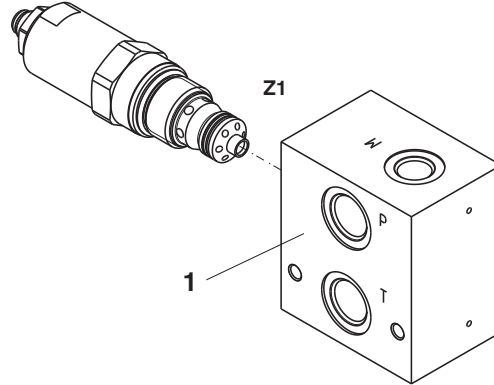
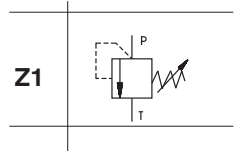
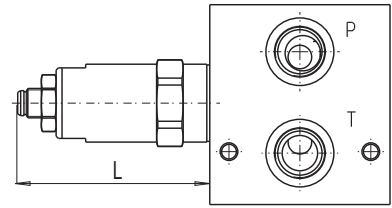
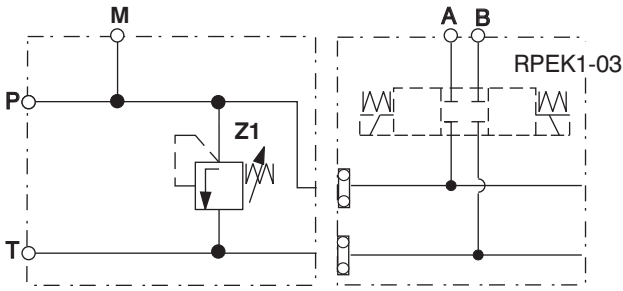

Pos.	Name	Type	Max. L [mm (in)]	Weight [kg (lb)]	Data sheet	Ordering number
1	Inlet Palate	HB03-RPEK-MPT1		0,407(0.897)		28813600
		HB03-RPEK-MPT1-S				29342300
Z1	Pressure valve	SR1A-B2	65 (2.56)		HA 5064	

Valve Dimensions - MPT1/- (S)

Dimensions in millimeters (inches)

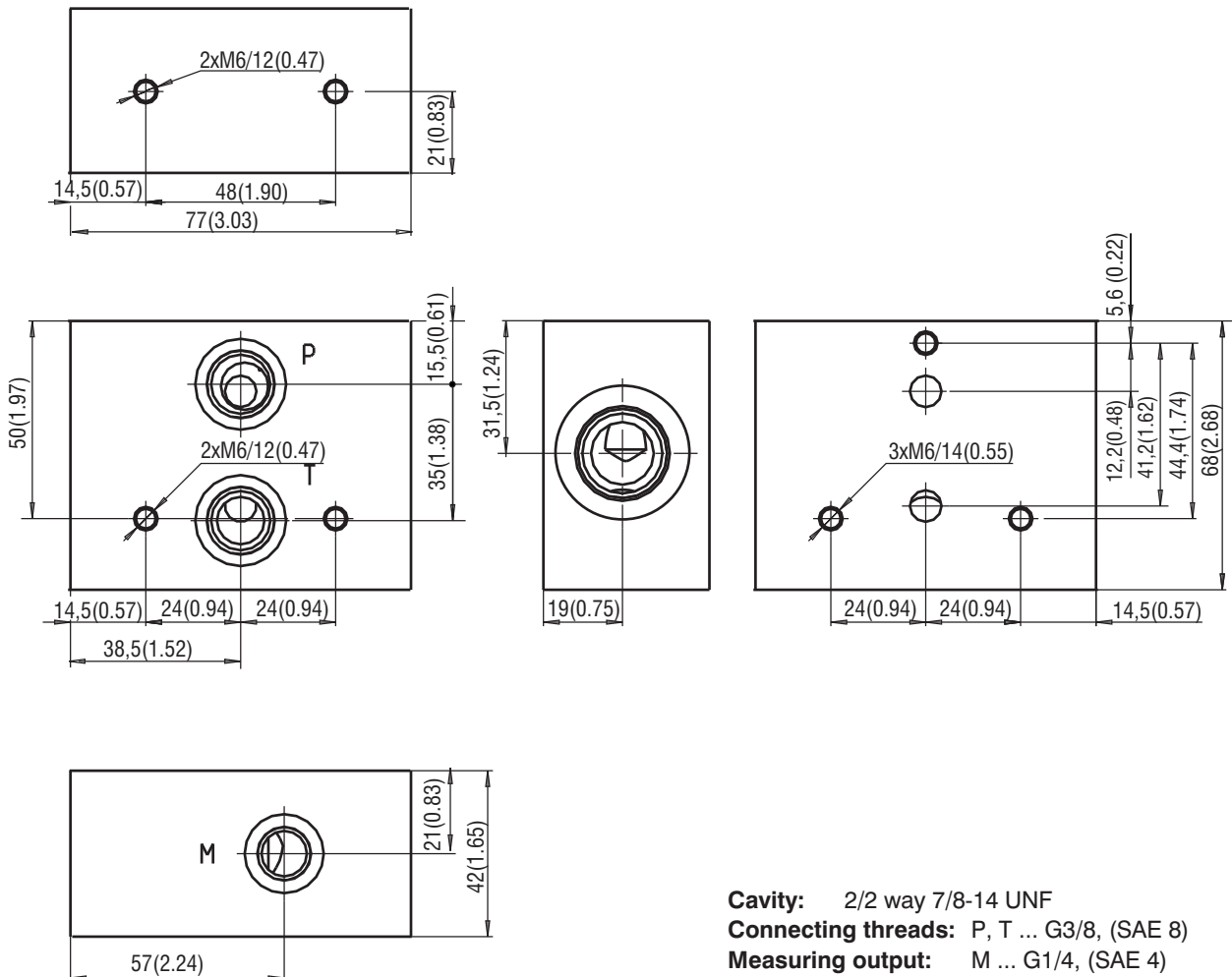

Cavity: 2/2 way 7/8-14 UNF
Connecting threads: P, T ... G3/8, (SAE 8)
Measuring output: M ... G1/4, (SAE 4)

Inlet Palate

HB03-RPEK-MPT2

29401100

1

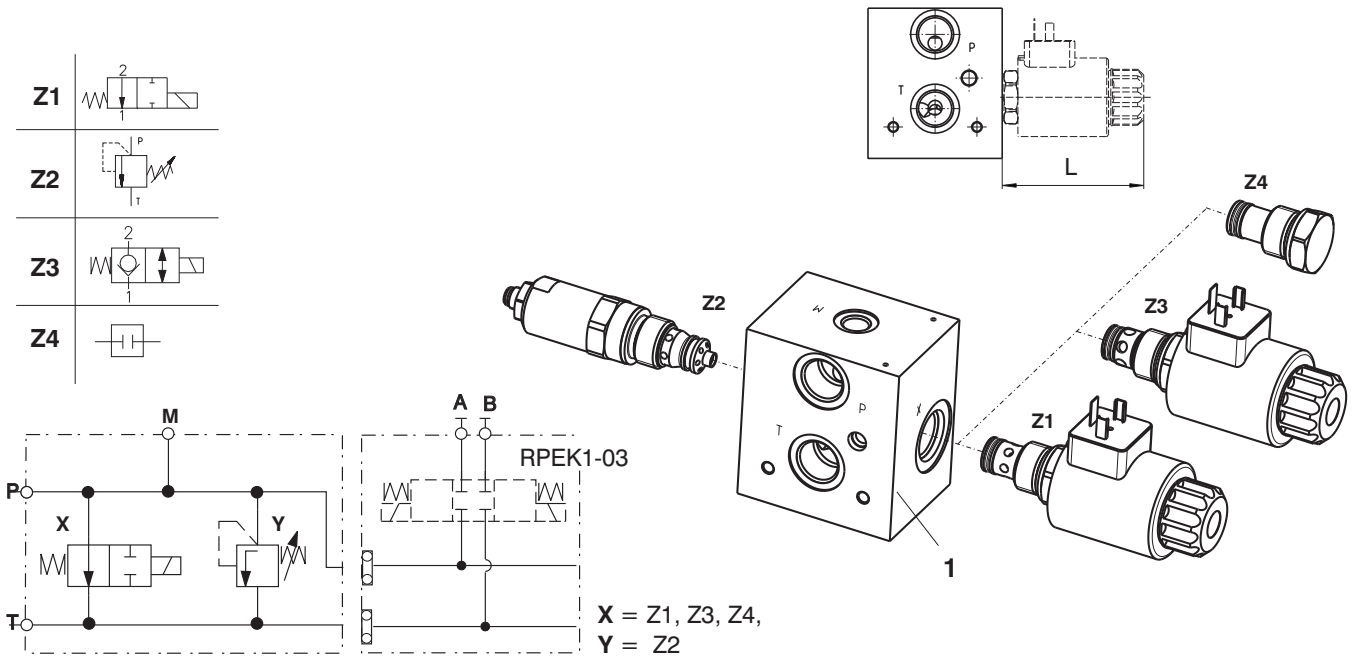

Pos.	Name	Type	Max. L [mm (in)]	Weight [kg (lb)]	Data sheet	Ordering number
1	Inlet Palate	HB03-RPEK-MPT2		0.934 (2.059)		29401100
Z1	Directional valve	SD2E-B2	82 (3.23)		HA 4060	
Z2	Pressure valve	SR1A-B2	65 (2.56)		HA 5064	
Z3	Directional valve	SD3E-B2	82 (3.23)		HA 4063	
Z4	Plug 2/2-7/8-14UNF		10 (0.39)			19356300

Valve Dimensions - MPT2

Dimensions in millimeters (inches)

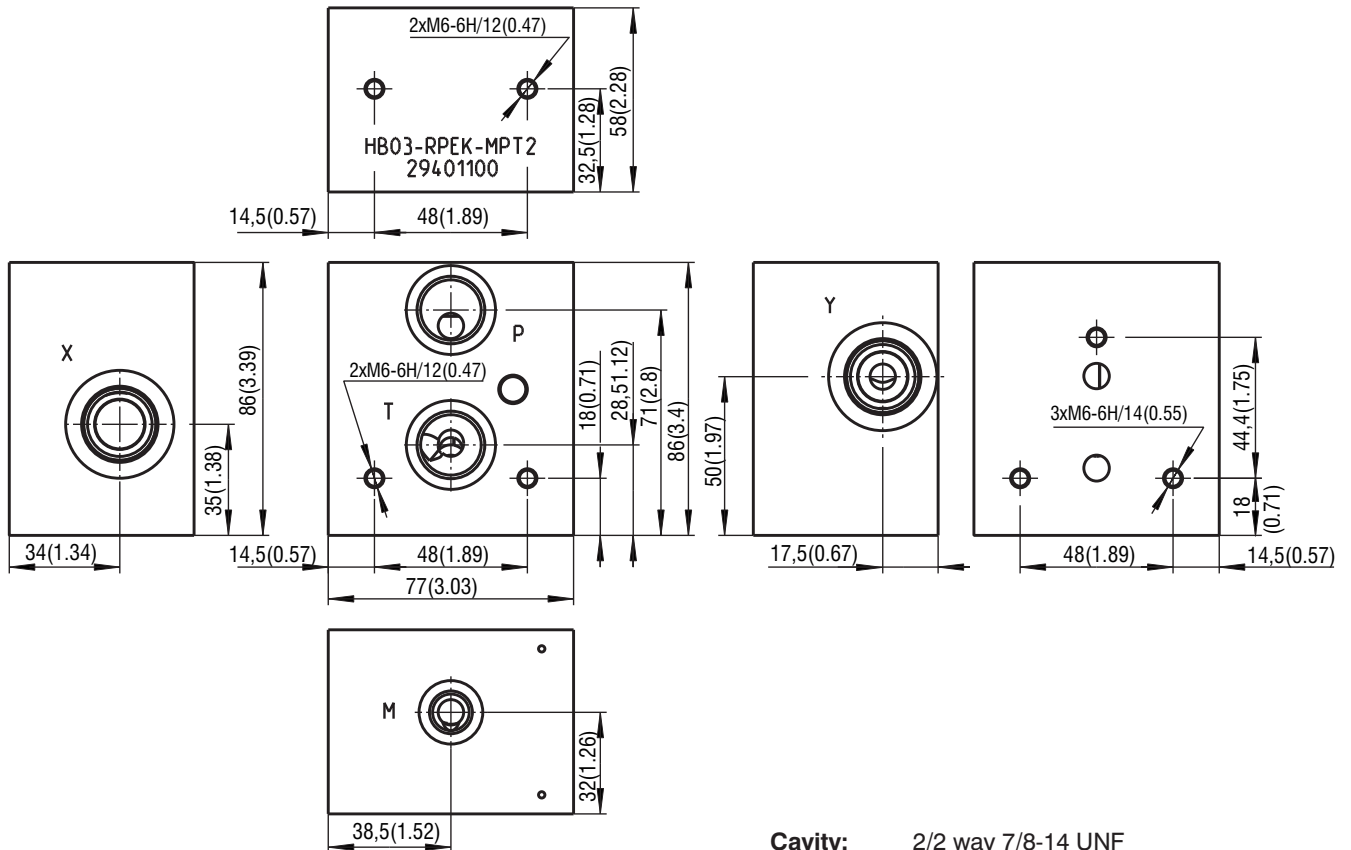

Cavity: 2/2 way 7/8-14 UNF
Connecting threads: P, T... G 1/2
Measuring output: M ... G1/4

Inlet Palate

HB03-RPEK-MZ/-(S)

28566300/(29342400)

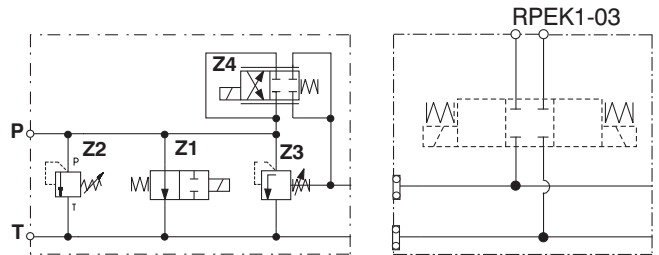
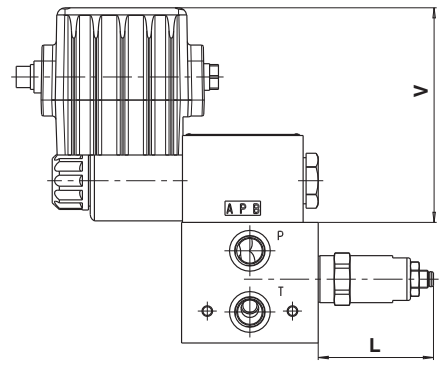
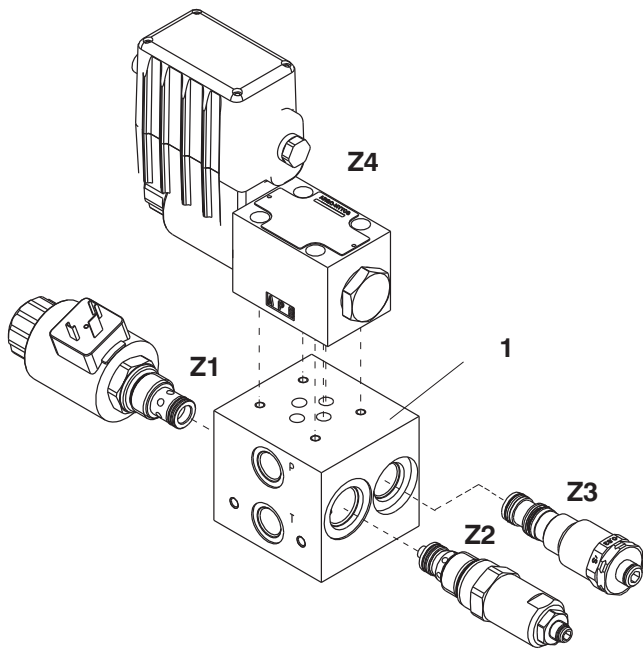

Pos.	Name	Type	Max. L [mm (in)]	Max. V [mm (in)]	Weight [kg (lb)]	Data sheet	Ordering number
1	Inlet Palate	HB03-RPEK-MZ			0,846 (1.865)		28566300
		HB03-RPEK-MZ-S					29342400
Z1	Directional valve	SD2E-B2	82 (3.23)			HA 4060	
Z2	Pressure valve	SR1A-B2	65 (2.56)			HA 5064	
Z3	3 way Pressure compensator	TV2-063	42 (1.65)			HA 5168	
Z4	Proportional valve	PRM2-06	140 (5.51)	121 (4.76)		HA 5105	
Z3	Plug 2/2-7/8-14UNF		10 (0.39)				19356300

Valve Dimensions - MZ/-(S)

Dimensions in millimeters (inches)

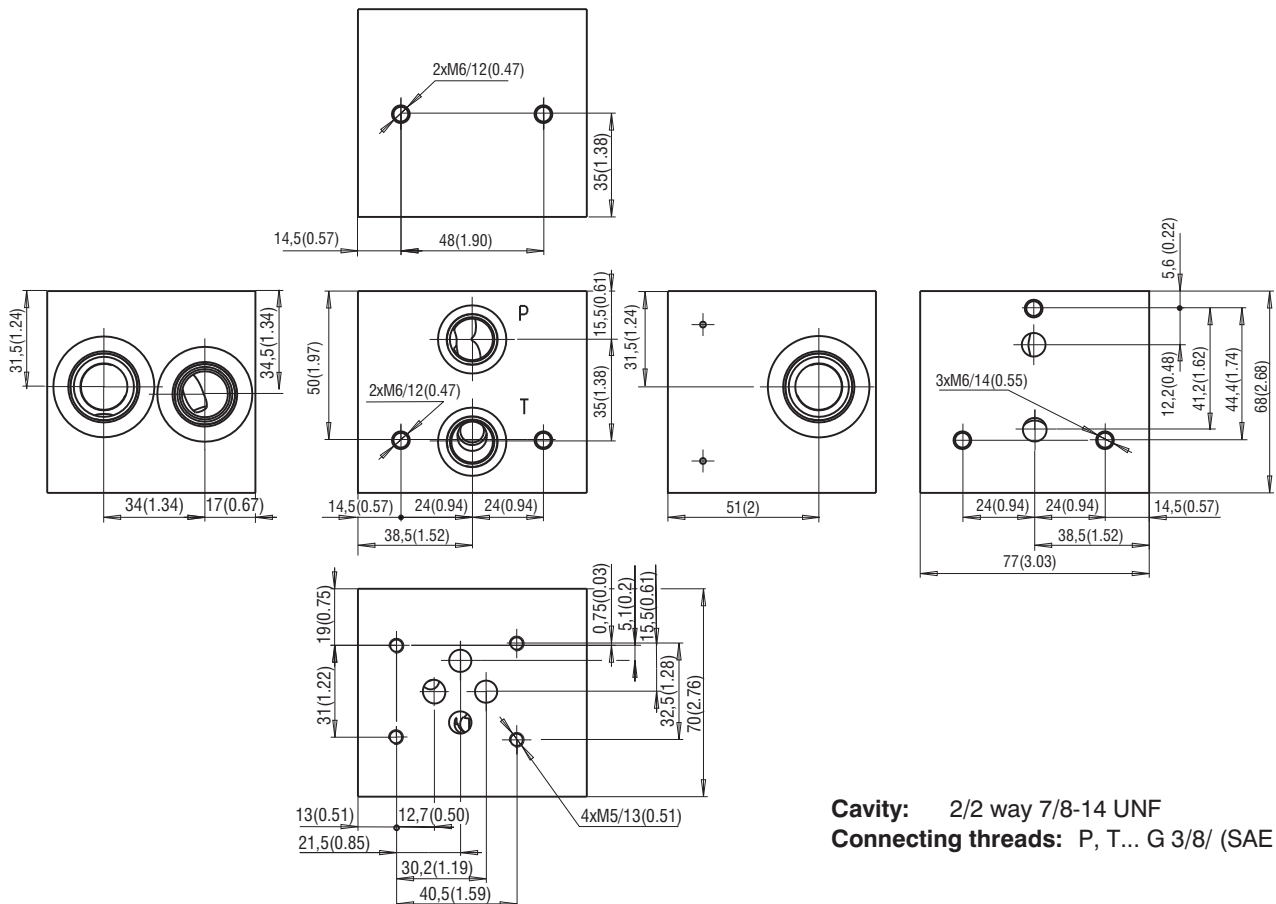

Cavity: 2/2 way 7/8-14 UNF
Connecting threads: P, T... G 3/8/ (SAE 8)

Centre P,T Plate HB03-RPEK-01/- (S)

28659800/(29344600)

- Bolt threads from both sides

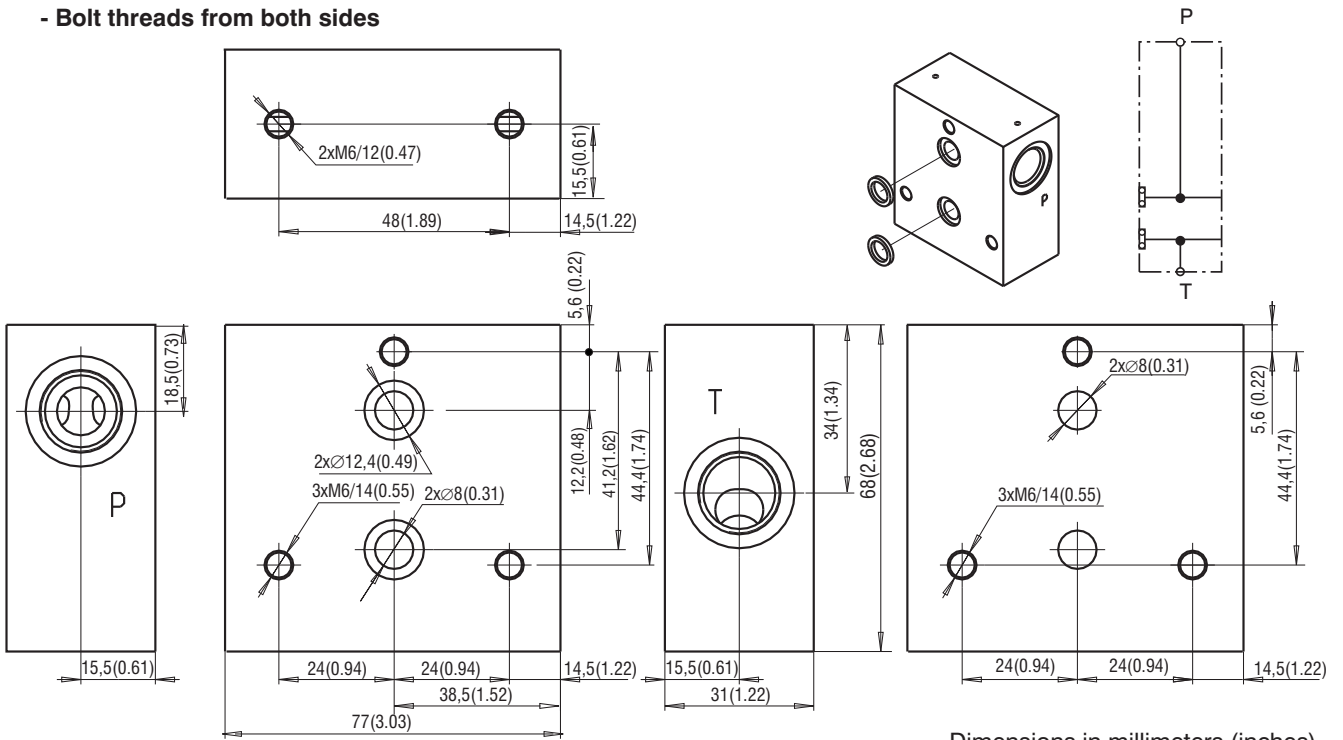

Centre P,T Plate HB03-RPEK-02/- (S)

28659900/(29344700)

- Bolt threads from both sides

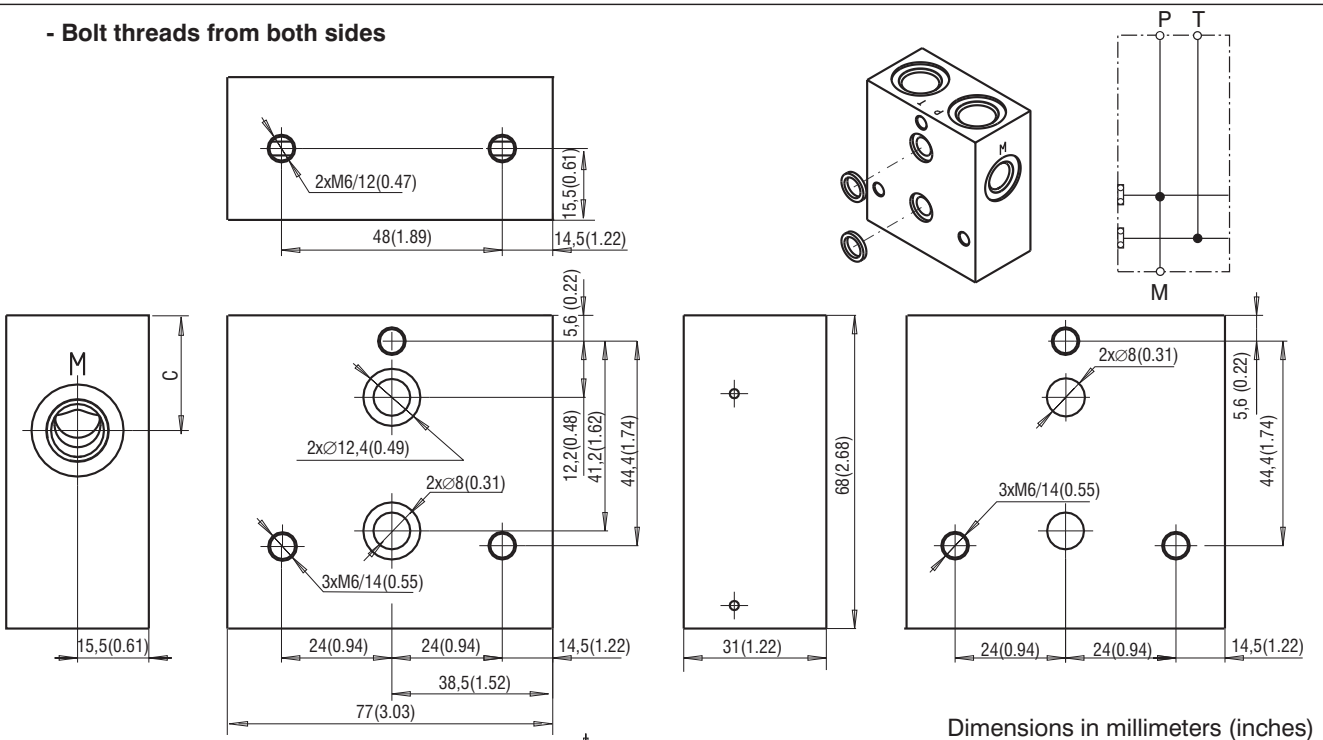

TYPE	A	B	C
G	22,5	32	20
	(0.89)	(1.60)	(0.79)
SAE	20,5	36	24
	(0.81)	(1.42)	(0.94)

Name	Type	Port size			Ordering number	Weight [kg (lb)]
		P	T	M		
Plate+seals	HB03-RPEK-01	G3/8	G3/8	-	28659800	0,318 (0.701)
Plate+seals	HB03-RPEK-01-S	SAE 8	SAE 8	-	29344600	
Plate+seals	HB03-RPEK-02	G3/8	G3/8	G1/4	28659900	0,318 (0.701)
Plate+seals	HB03-RPEK-02-S	SAE 8	SAE 8	SAE 4	29344700	

Centre P,T Plate HB03-RPEK-03/- (S)

28660000/(29344800)

- through holes for bolts - straight

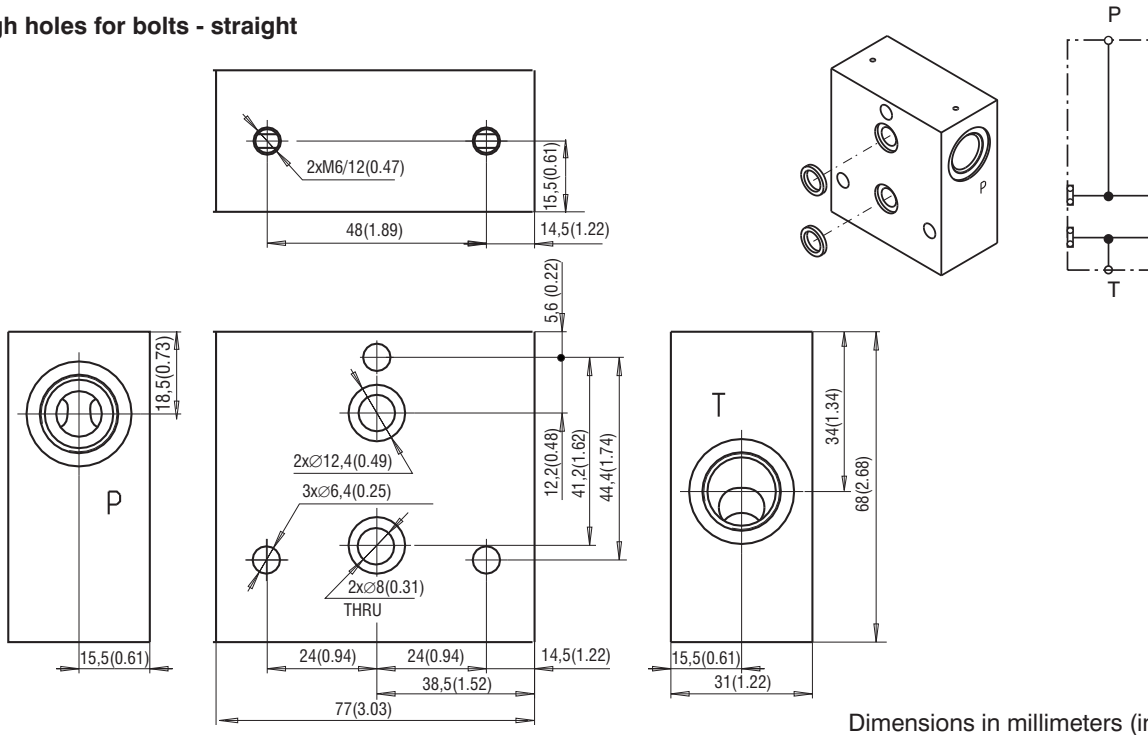

Dimensions in millimeters (inches)

Centre P,T Plate HB03-RPEK-04/- (S)

28660100/(29344900)

- through holes for bolts - straight

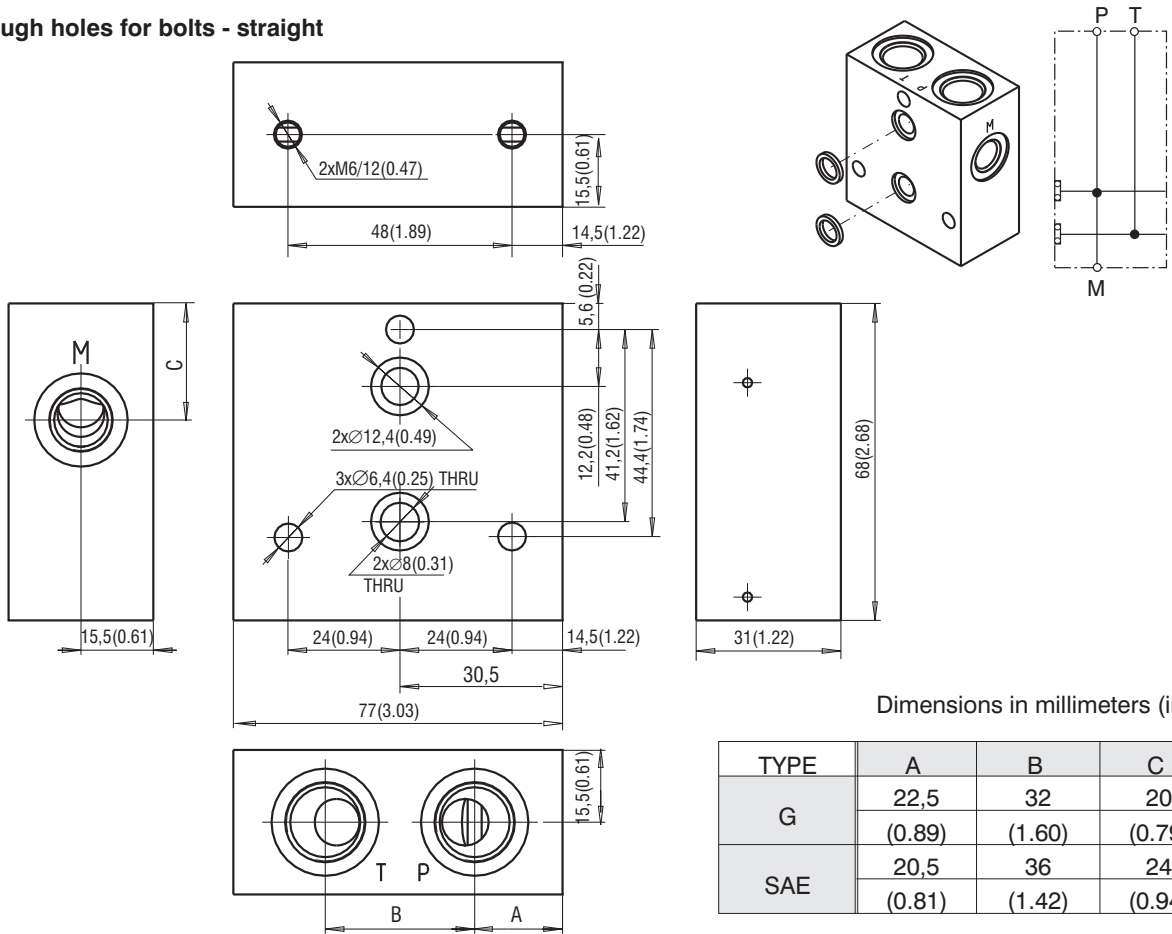

Dimensions in millimeters (inches)

TYPE	A	B	C
G	22,5	32	20
	(0.89)	(1.60)	(0.79)
SAE	20,5	36	24
	(0.81)	(1.42)	(0.94)

Name	Type	Port size			Ordering number	Weight [kg (lb)]
		P	T	M		
Plate+seals	HB03-RPEK-03	G3/8	G3/8	-	28660000	0,315 (0.694)
Plate+seals	HB03-RPEK-03-S	SAE 8	SAE 8	-	29344800	
Plate+seals	HB03-RPEK-04	G3/8	G3/8	G1/4	28666010	0,305 (0.672)
Plate+seals	HB03-RPEK-04-S	SAE 8	SAE 8	SAE 4	29344900	

End Plate

HB03-RPEK-05

16786901

- without sealing rings

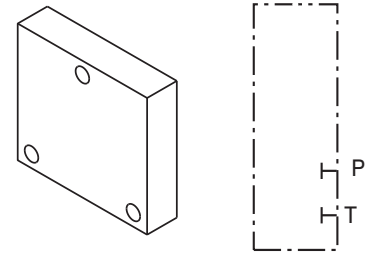
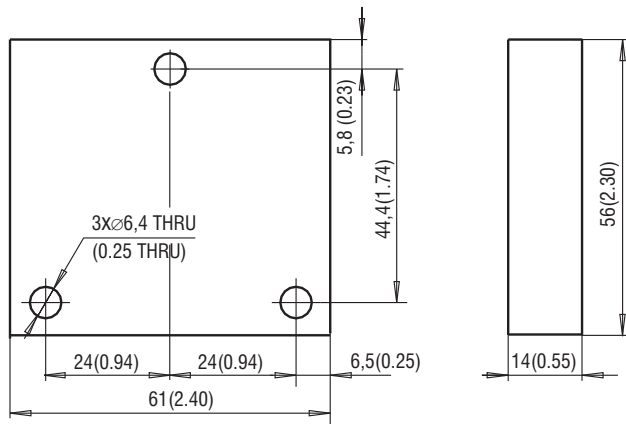

Dimensions in millimeters (inches)

Inlet P,T Plate

HB03-RPEK-06/- (S)

28566800/(29343300)

- without recess for sealing

Dimensions in millimeters (inches)

TYPE	A	B
G	23 (0.91)	23 (0.91)
SAE	18 (0.71)	21 (0.83)

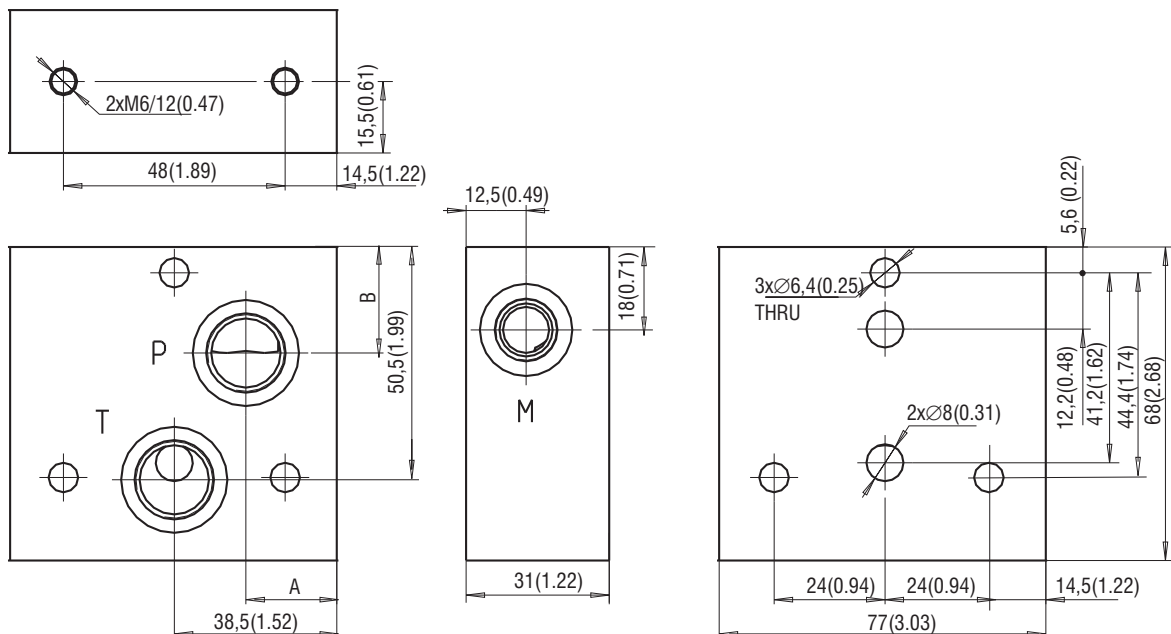
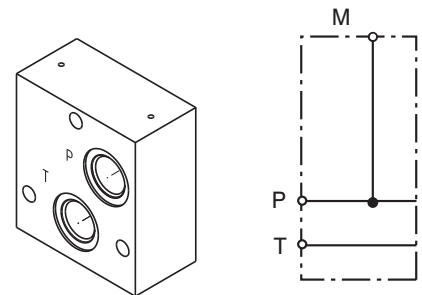

Name	Type	Port size			Ordering number	Weight [kg (lb)]
		P	T	M		
Plate	HB03-RPEK-05	-	-	-	16786901	0,130 (0.287)
Plate	HB03-RPEK-06	G3/8	G3/8	G1/4	28566800	0,315 (0.694)
Plate	HB03-RPEK-06-S	SAE 8	SAE 8	SAE 4	29343300	

Inlet P,T Plate HB03-RPEK-07/- (S)

28660200/(29345000)

- with sealing rings

Dimensions in millimeters (inches)

TYPE	A	B
G	23 (0.91)	23 (0.91)
SAE	18 (0.71)	21 (0.83)

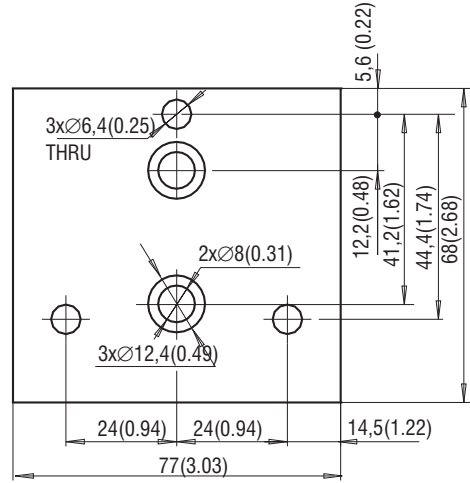
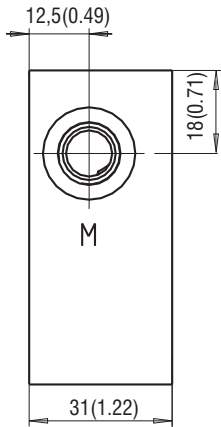
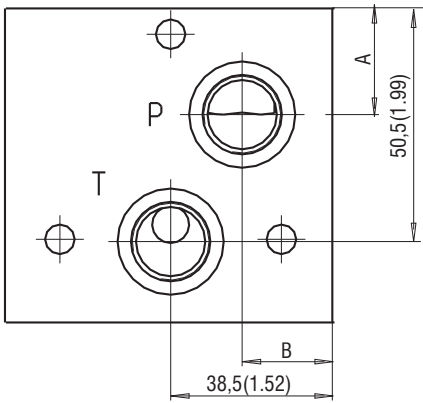
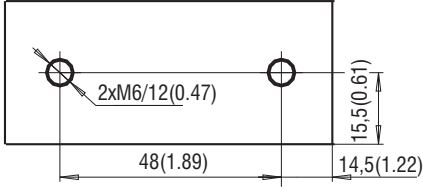
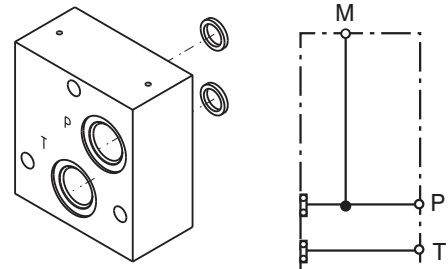

End Plate HB03-RPEK-08

28660300

- with sealing rings

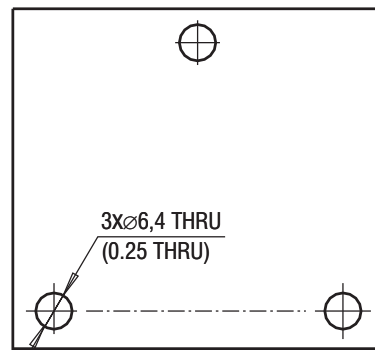
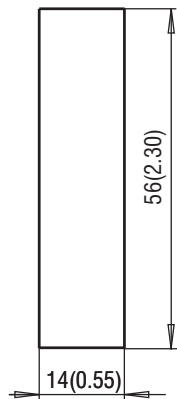
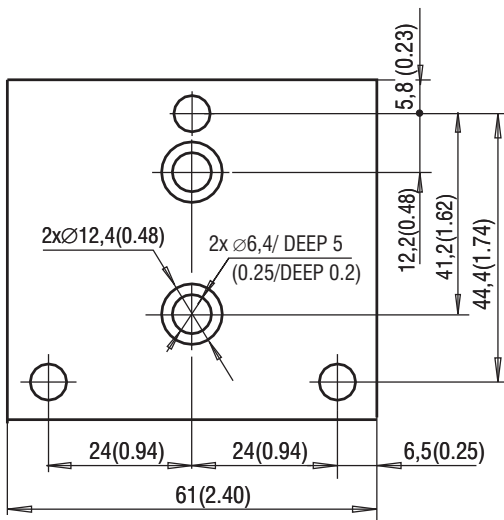
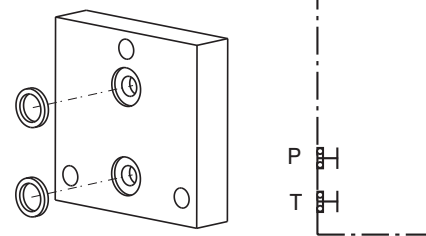

Dimensions in millimeters (inches)

Name	Type	Port size			Ordering number	Weight [kg (lb)]
		P	T	M		
Plate+seals	HB03-RPEK-07	G3/8	G3/8	G1/4	28660200	0,314 (0.692)
Plate+seals	HB03-RPEK-07-S	SAE 8	SAE 8	SAE 4	29345000	
Plate+seals	HB03-RPEK-08	-	-	-	28660300	0,135 (0.298)

Sandwich Plate

HB03-RPEK-MP1/- (S)

28658500/(29344000)

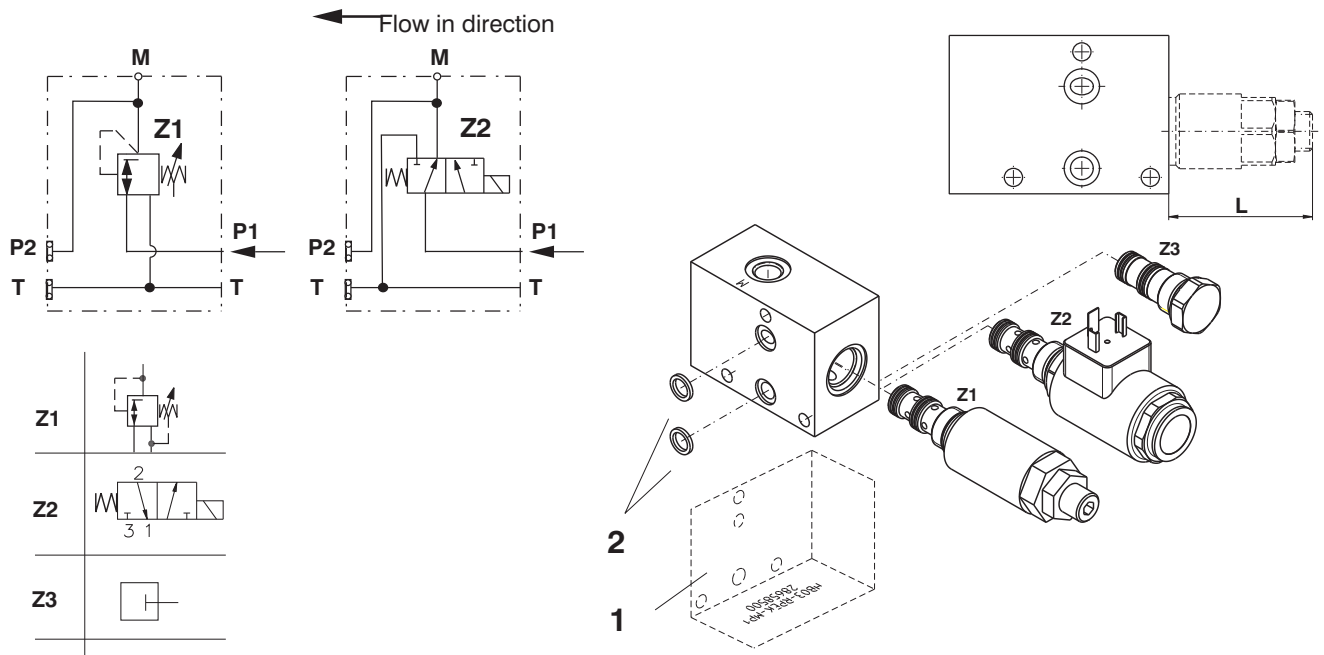

Pos.	Name	Type	Max. L [mm (in)]	Weight [kg (lb)]	Data sheet	Ordering number
1	Sandwich plate + seals	HB03-RPEK-MP1		0,325(0.716)		28658500
		HB03-RPEK-MP1-S				29344000
Z1	Pressure valve	SP2A-A3	77 (3.03)		HA 5143	
Z2	Directional valve	SD2E-A3	70 (2.75)		HA 4041	
Z3	Plug 3/4-16UNF		5 (0.20)			22751900
2	Spare Seal kit- Square ring					
	Standard - NBR70		9,25 x 1,68 (2 pcs.)			15608800
	Viton		9,25 x 1,78 (2 pcs.)			20152400

Valve Dimensions - MP1/- (S)

Dimensions in millimeters (inches)

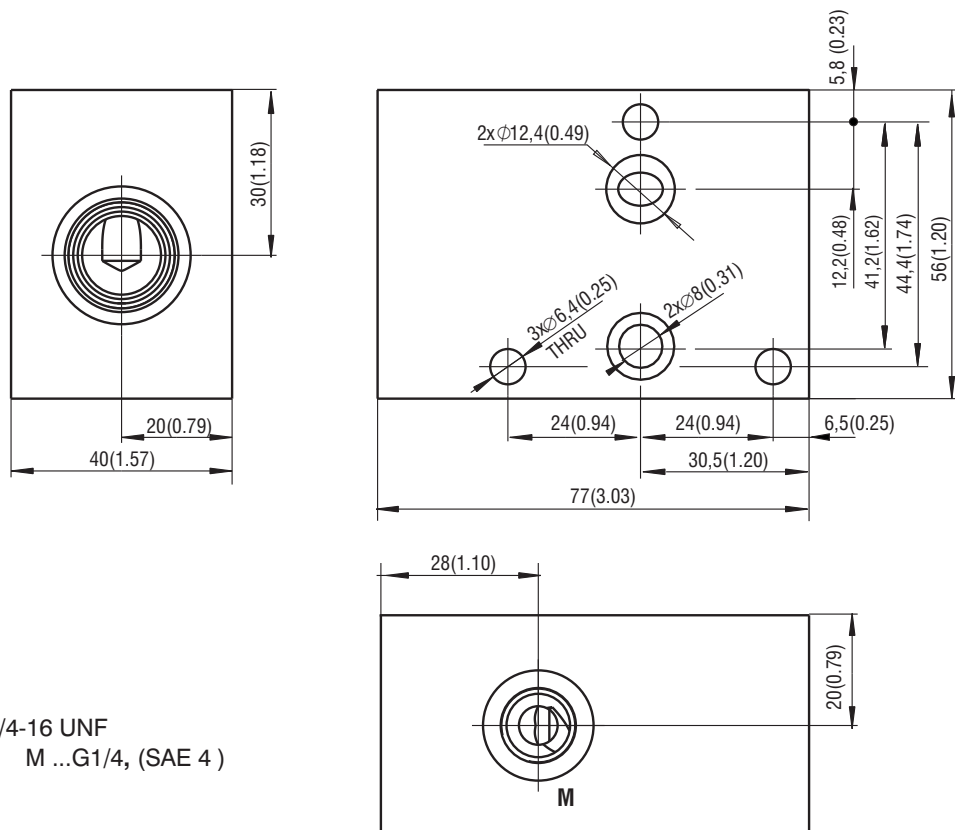

Cavity: 3/2 way 3/4-16 UNF
Measuring output: M ...G1/4, (SAE 4)

Sandwich Plate

HB03-RPEK-MP2/-(S)

28658900/(29344100)

1

→ Flow in direction

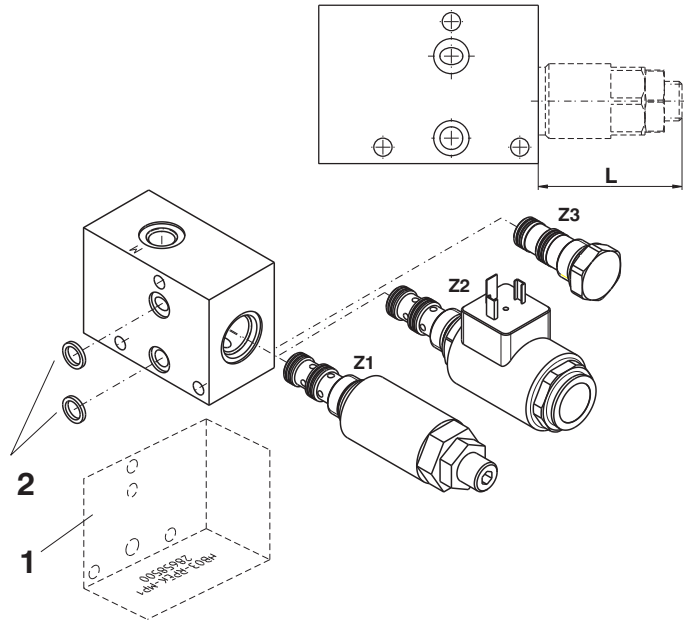
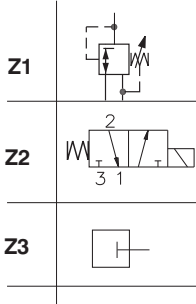
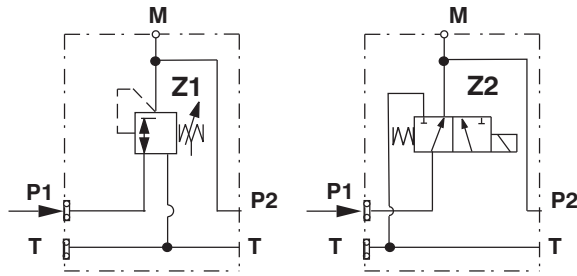

Pos.	Name	Type	Max. L [mm (in)]	Weight [kg (lb)]	Data sheet	Ordering number
1	Sandwich Plate + seals	HB03-RPEK-MP2		0,325(0.716)		28658900
		HB03-RPEK-MP2-S				29344100
Z1	Pressure reducing valve	SP2A-A3	77 (3.03)		HA 5143	
Z2	Directional valve	SD2E-A3	70 (2.75)		HA 4041	
Z3	Plug 3/4-16UNF		5 (0.20)			22751900
2	Spare Seal kit- Square ring					
	Standard - NBR70		9,25 x 1,68 (2 pcs.)			15608800
	Viton		9,25 x 1,78 (2 pcs.)			20152400

Valve Dimensions - MP2/-(S)

Dimensions in millimeters (inches)

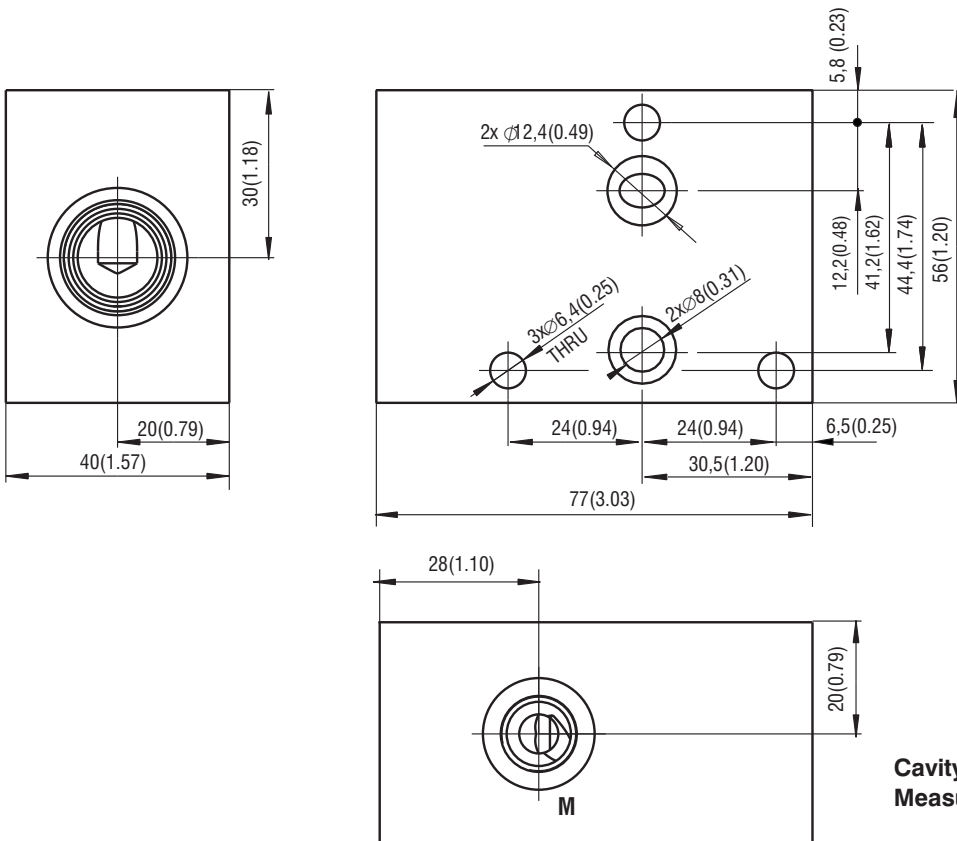

Cavity: 3/2 way 3/4-16 UNF
Measuring output: M ...G1/4, (SAE 4)

Sandwich Plate

HB03-RPEK-MC

28659200

1

CONNECTION A-B, B-A

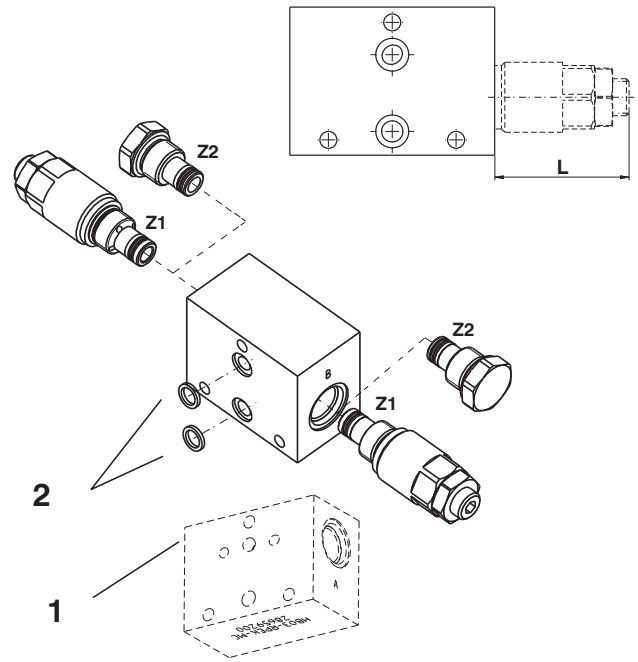
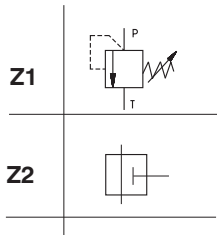
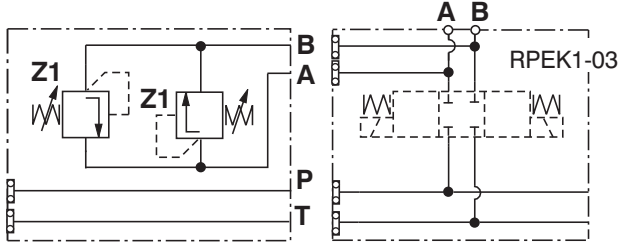

Pos.	Name	Type	max L [mm (in)]	Weight [kg (lb)]	Data sheet	Ordering number
1	Block + seals	HB03-RPEK-MC		0,379 (0.835)		28659200
Z1	Pressure valve	SR1A-A2	49,5 (1.95)		HA 5063	
Z2	Plug 2/2- 3/4-16UNF		7,5 (0.29)			15960800
Spare Seal kit- Square ring						
2	Standard - NBR70		9,25 x 1,68 (2 pcs.)			15608800
	Viton		9,25 x 1,78 (2 pcs.)			20152400

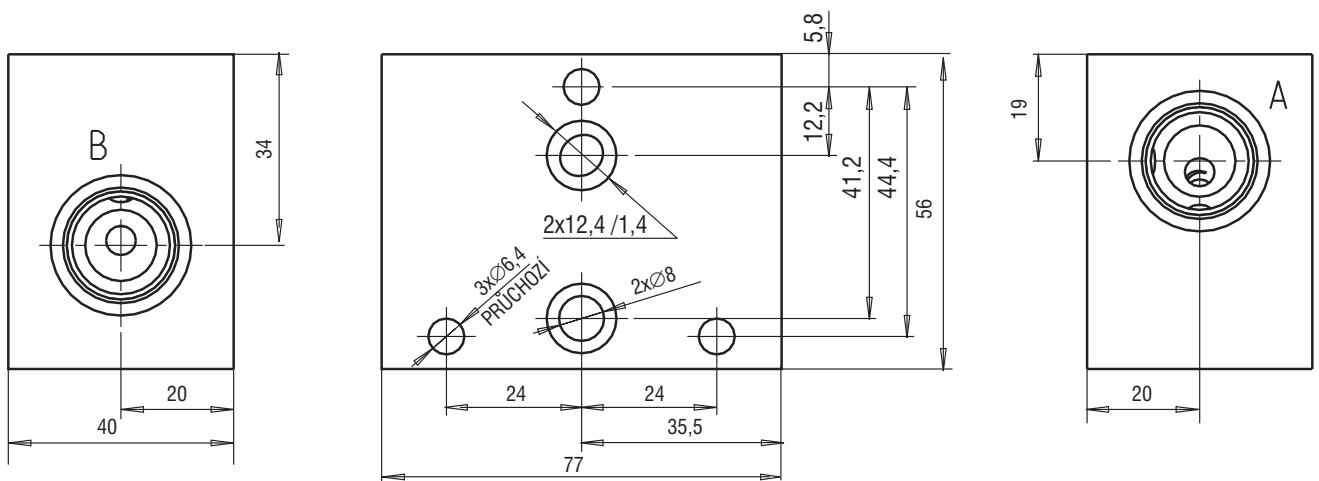

Cavity: 2/2-3/4-16 UNF

Sandwich Plate

HB03-RPEK-MD

28659400

CONNECTION A-T, B-T

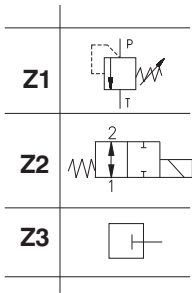
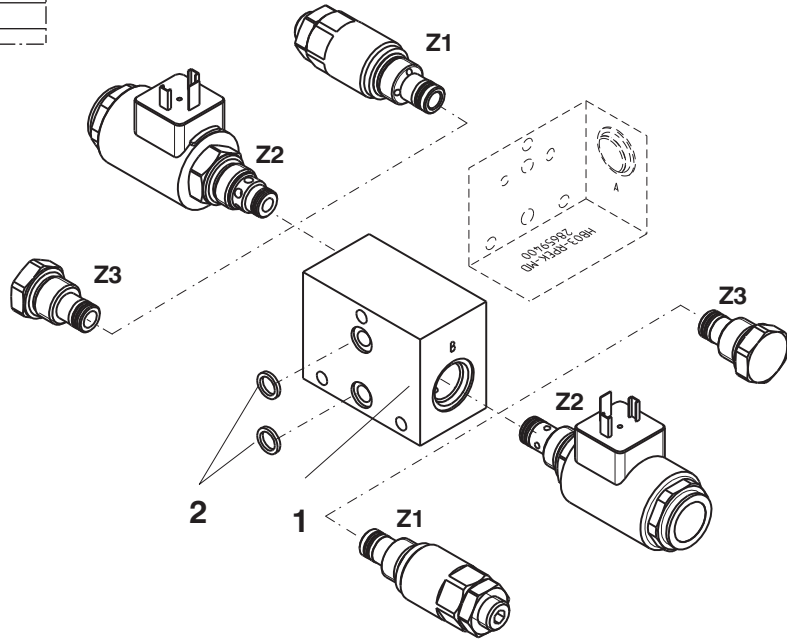
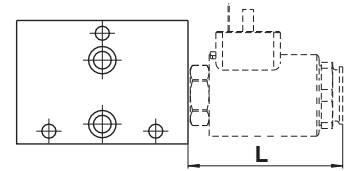
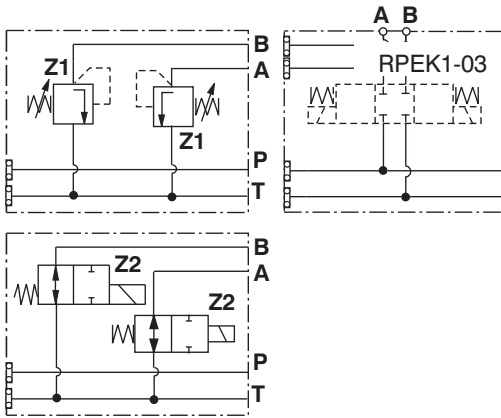

Pos.	Name	Type	Max. L [mm (in)]	Weight [kg (lb)]	Data sheet	Ordering number
1	Sandwich Plate + seals	HB03-RPEK-MD		0,378(0.833)		28659400
Z1	Pressure valve	SR1A-A2	49,5 (1.95)		HA 5063	
Z2	Directional valve	SD2E-A2	70 (2.75)		HA 4040	
Z3	Plug 3/4-16UNF		7,5 (0.29)			15960800
Spare Seal kit- Square ring						
2	Standard - NBR70		9,25 x 1,68 (2 pcs.)			15608800
	Viton		9,25 x 1,78 (2 pcs.)			20152400

Valve Dimensions - MD

Dimensions in millimeters (inches)

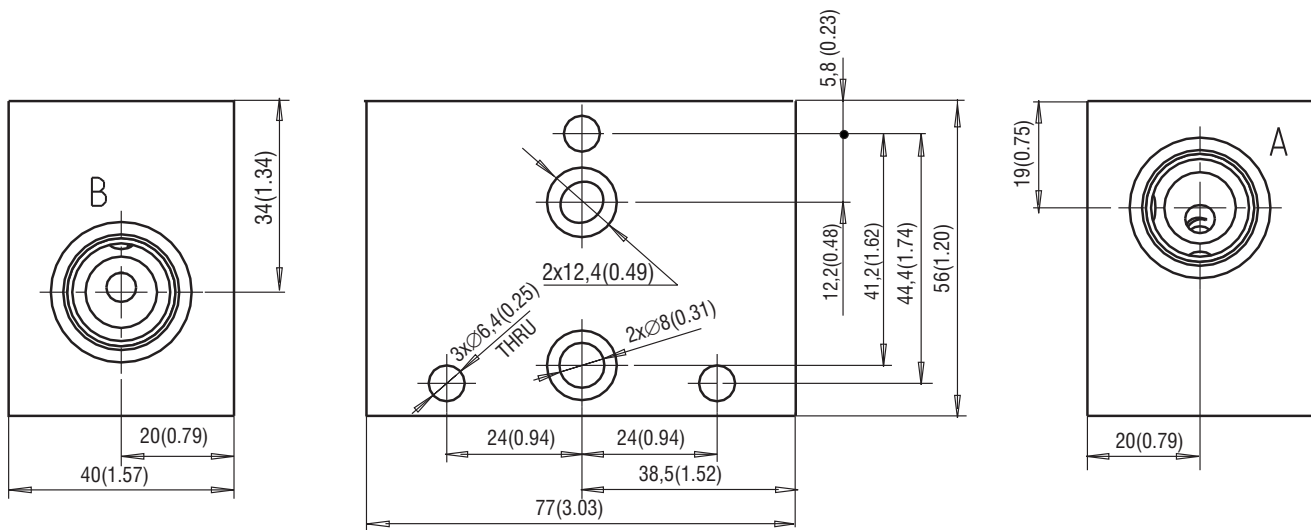

Cavity: 2/2 way 3/4-16 UNF

Sandwich Plate

HB03-RPEK-MAB/-(S)

28659700/(29344200)

1

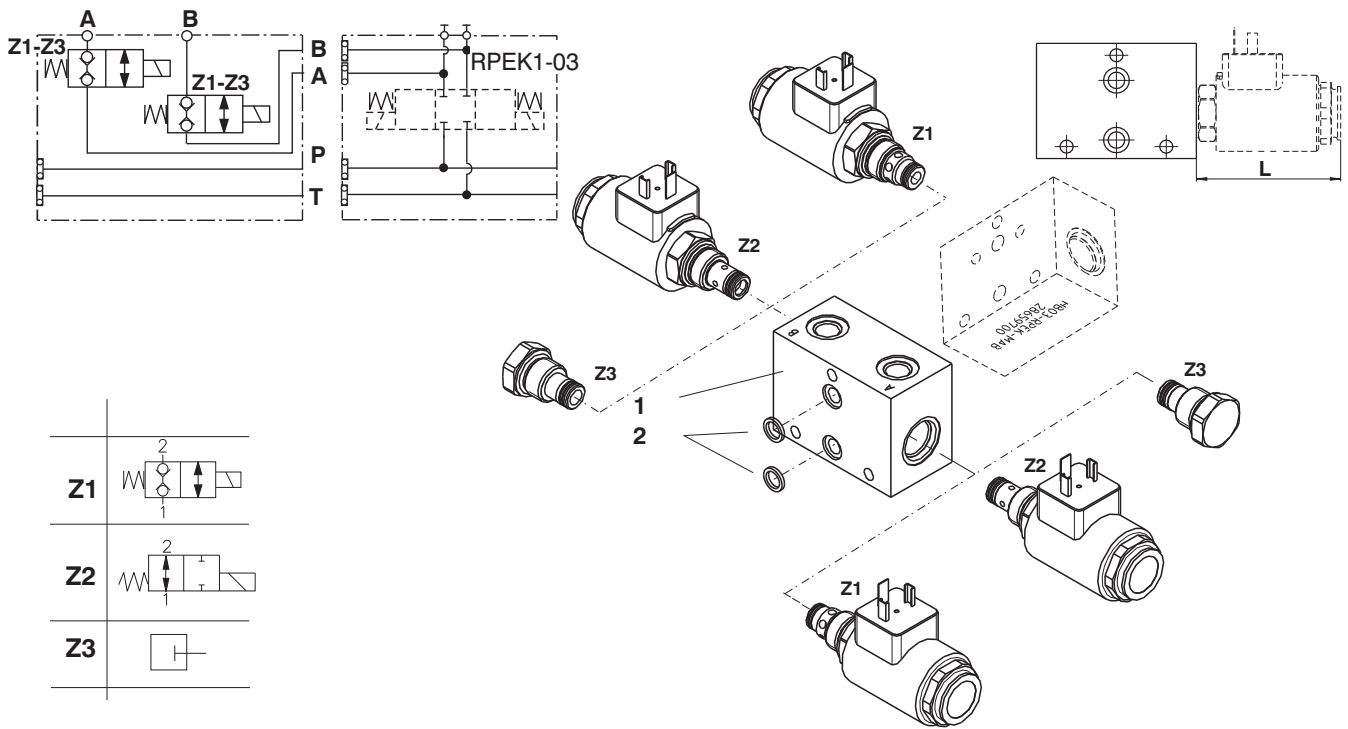

Pos.	Name	Type	Max. L [mm (in)]	Weight [kg (lb)]	Data sheet	Ordering number
1	Sandwich Plate + seals	HB03-RPEK-MAB		0,407(0.897)		28659700
		HB03-RPEK-MAB-S				29344200
Z1	Directional valve	SD3E-A2	70 (2.75)		HA 4043	
Z2	Directional valve	SD2E-A2	70 (2.75)		HA 4040	
Z3	Plug 3/4-16UNF		7,5(0.29)			15960800
2	Spare Seal kit- Square ring					
	Standard - NBR70		9,25 x 1,68 (2 pcs.)			15608800
	Viton		9,25 x 1,78 (2 pcs.)			20152400

Valve Dimensions - MAB/-(S)

Dimensions in millimeters (inches)

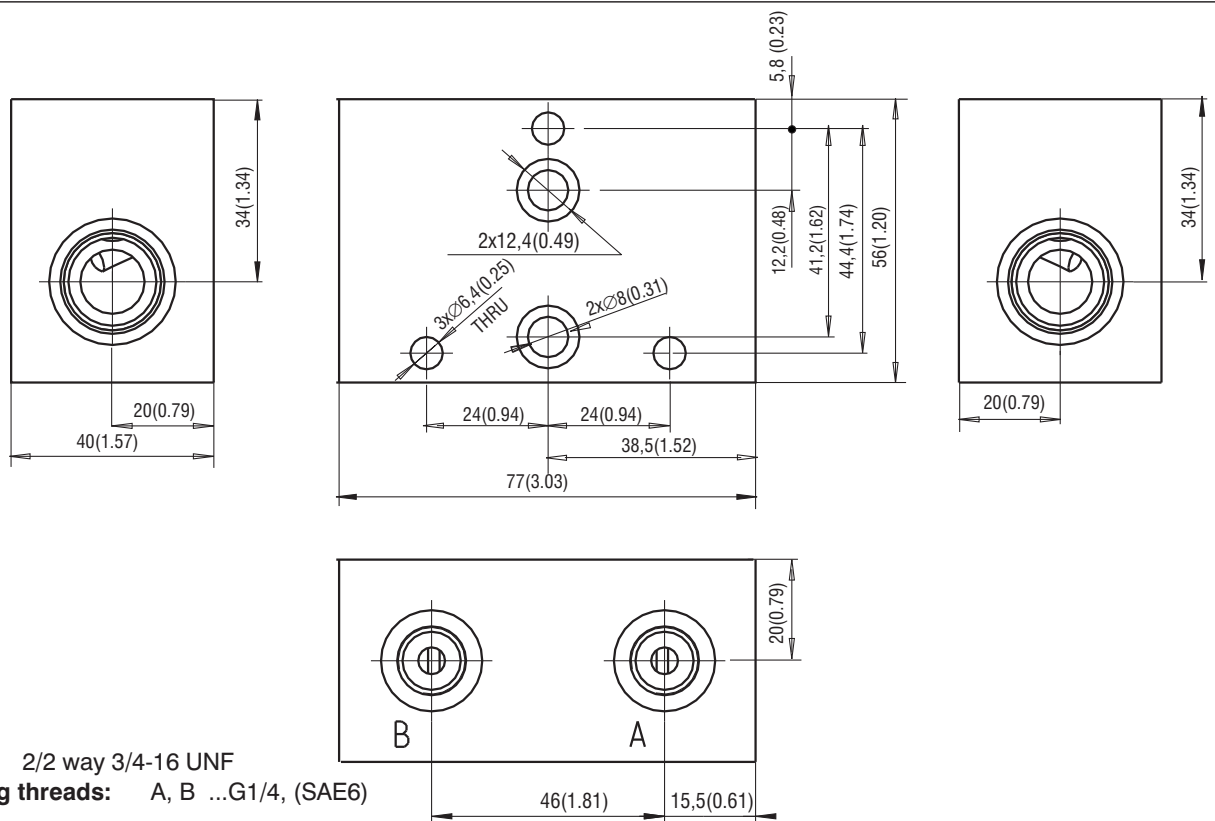

Cavity: 2/2 way 3/4-16 UNF
Connecting threads: A, B ...G1/4, (SAE6)

Sandwich Plate

HB03-RPEK-MAB1/-(S)

28650700/(29344500)

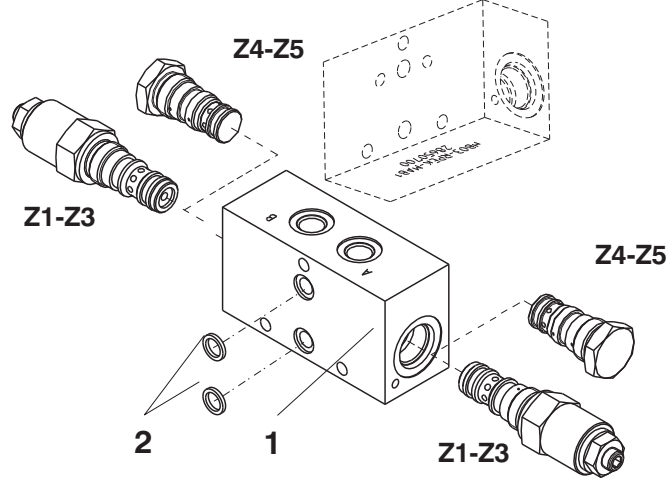
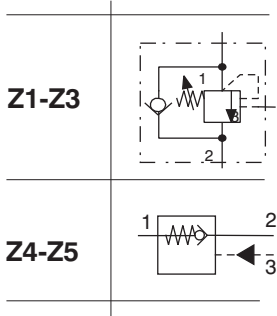
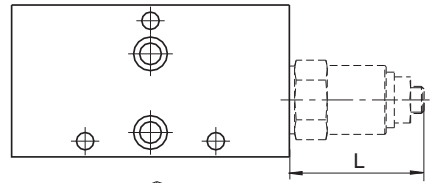
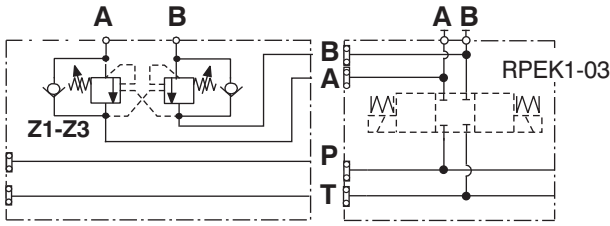

Pos.	Name	Type	Max. L [mm (in)]	Weight [kg (lb)]	Data sheet	Ordering number
1	Sandwich Plate + seals	HB03-RPEK-MAB1		0,532(1.173)		28650700
		HB03-RPEK-MAB1-S				29344500
Z1	Overcentre valve	SOPA-Q3	47 (1.85)		HA 5200	
Z2	Overcentre valve	SOP5A-Q3/I	47 (1.85)		HA 5201	
Z3	Overcentre valve	SOB5A-Q3/I	47 (1.85)		HA 5202	
Z4	Check valve	SC5H-Q3/I	7 (0.27)		HA 5217	
Z5	Check valve	SCC5H-Q3/I	7 (0.27)		HA 5221	
2	Spare Seal kit- Square ring					
	Standard - NBR70		9,25 x 1,68 (2 pcs.)			15608800
	Viton		9,25 x 1,78 (2 pcs.)			20152400

Valve Dimensions - MAB1/-(S)

Dimensions in millimeters (inches)

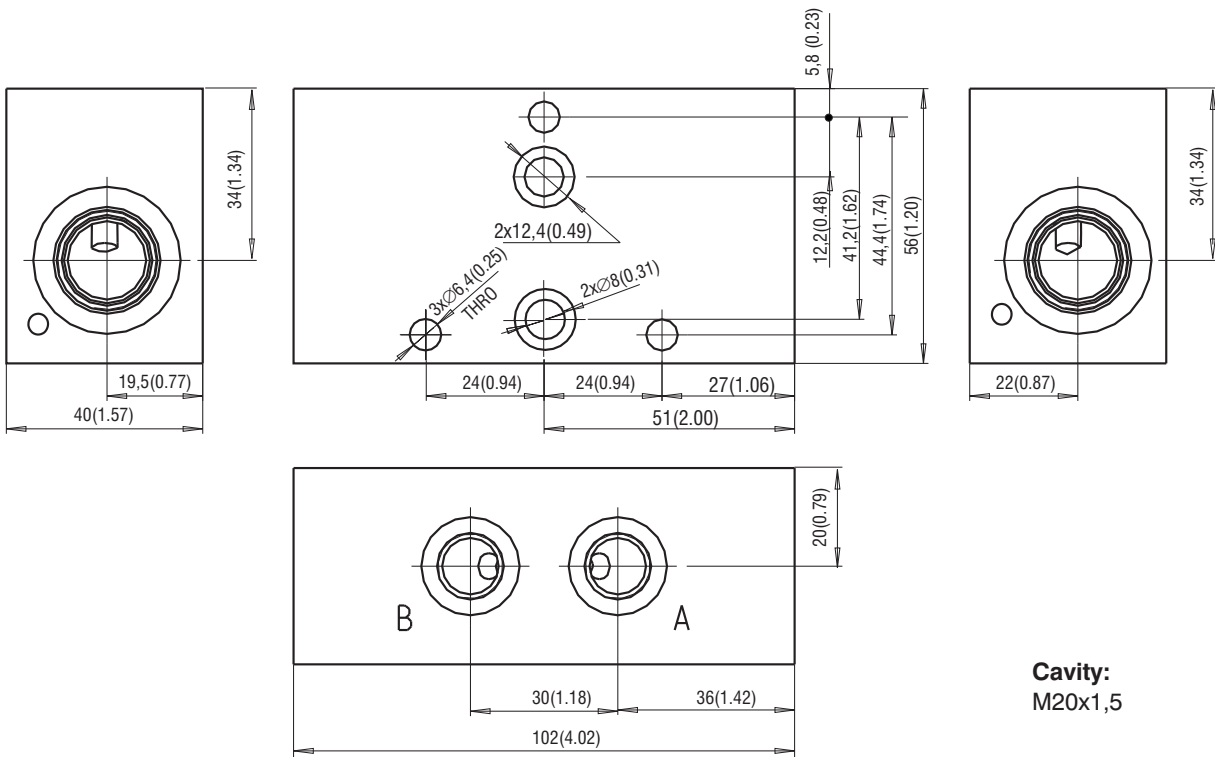

Cavity:
M20x1,5

Sandwich Plate

HB03-RPEK-MAB2

29397800

1

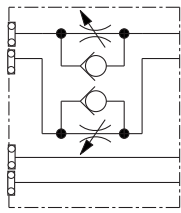

Z1-Z5

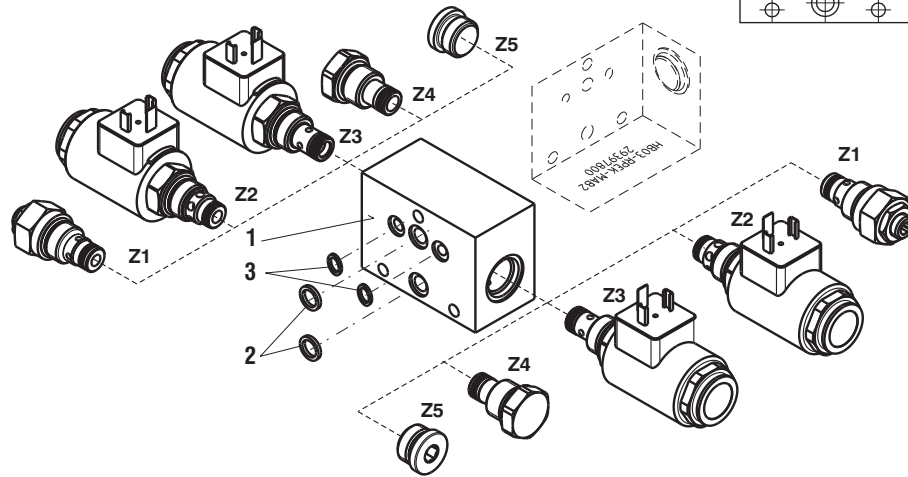
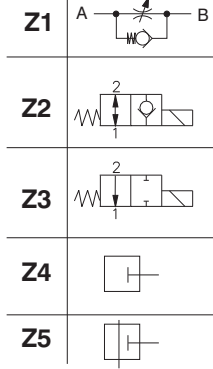
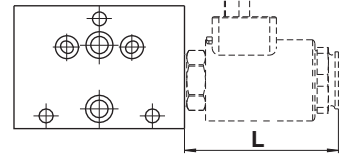

Pos.	Name	Type	Max. L [mm (in)]	Weight [kg (lb)]	Data sheet	Ordering number
1	Sandwich Plate +seals	HB03-RPEK-MAB2		0,415(0.915)		29397700
Z1	Flow valve	VSV2-J1-3/4-16UNF	22 (0.87)		HA 5132	29399300
Z2	Directional valve	SD3E-A2	70 (2.75)		HA 4043	
Z3	Directional valve	SD2E-A2	70 (2.75)		HA 4040	
Z4	Plug 3/4-16UNF		7,5 (0.29)			15960800
Z5	Plug 3/4-16UNF		3 (0.12)			15625300
Spare Seal kit- Square ring						
2	Standard - NBR70	9,25 x 1,68 (2 pcs.)				15608800
	Viton	9,25 x 1,78 (2 pcs.)				20152400
3	DKAR 00011BN7033	7,65 x 1,68 (2 pcs.)				15608700

Valve Dimensions - MAB2

Dimensions in millimeters (inches)

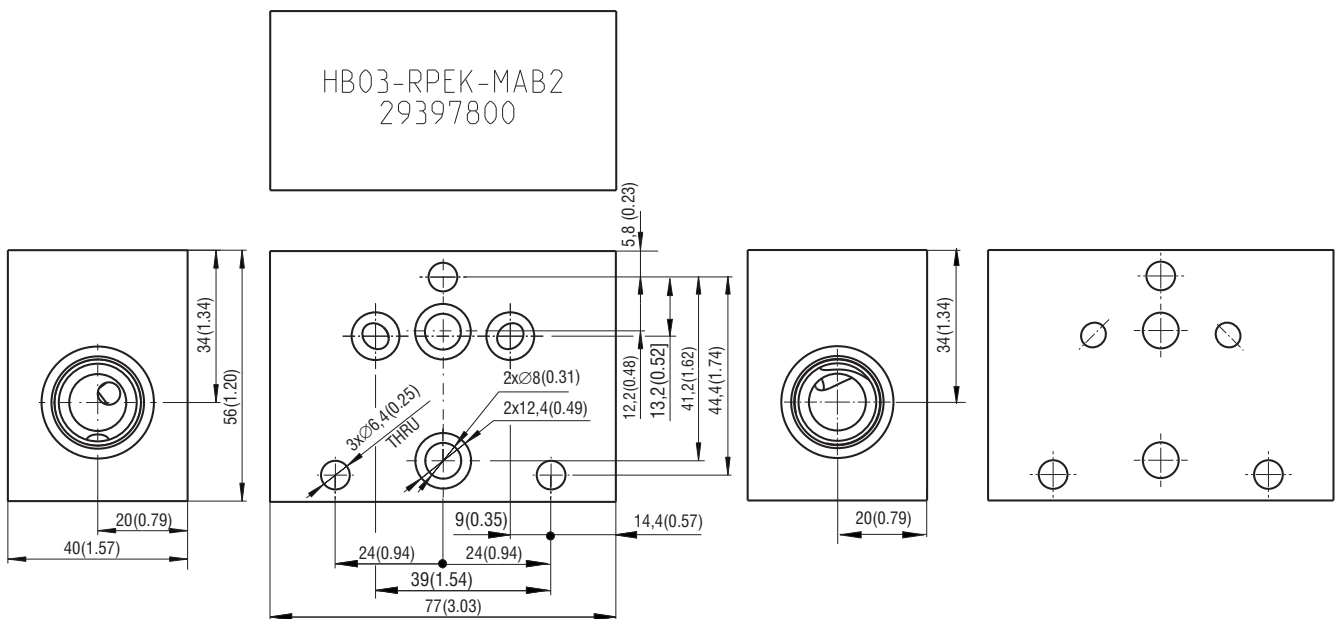

Cavity: 2/2 way 3/4-16 UNF

Mounting Angle

Dimensions in millimeters (inches)

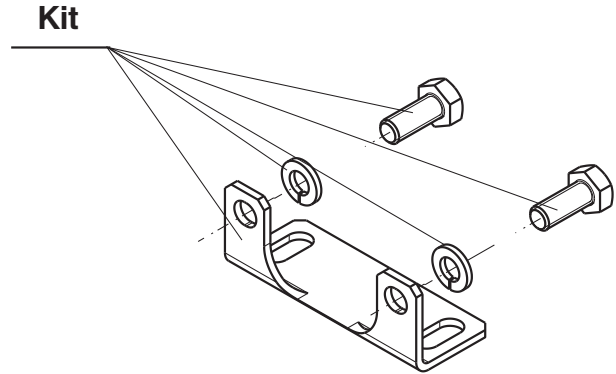
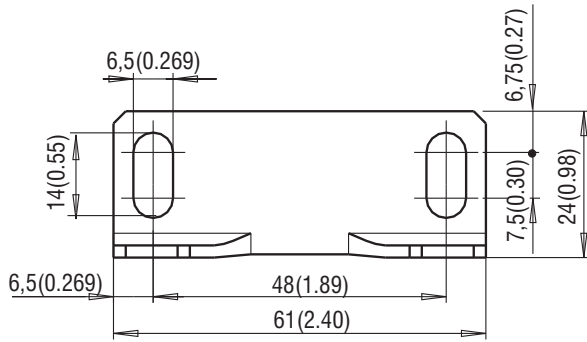
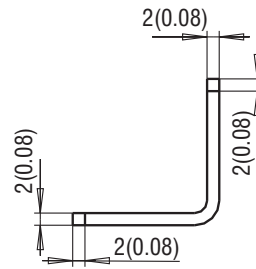
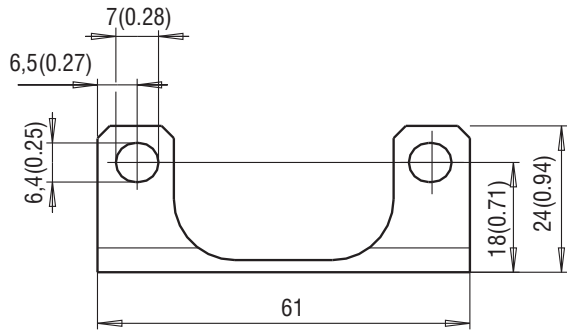

Name		Tightening torque	Ordering number / Kit
Kit	Mounting Angle (1 pc.)	12 (8.85) [Nm (lbf-ft)]	28799600
	Bolt M6 x 12 (2 pcs.)		
	Washer 6 (2 pcs.)		

Spare Parts - Plates

Seal kit - Square ring		
Name	Dimensions, number	Ordering number
Standard - NBR70	9,25 x 1,68 (2 pcs.)	15608800
Viton	9,25 x 1,78 (2 pcs.)	20152400

M6 BOLTS/STUDS LENGTH – for Horizontal Assembly (Mu -12 (8.85)[Nm (lbf-ft)])

1

$$L = (L1 \times X) + (L2 \times X) + (L3 \times X) + Y$$

- L = total length** (to 100 cm screw bolt hereinafter)
L1 = 40 mm (1.57 in) (Horizontal plate with length 40 mm (1.57 in))
L2 = 31 mm (1.22 in) (Horizontal plate with length 31 mm (1.22 in))
L3 = 14 mm (0.55 in) (End plate)
X = Number of plates of the given width (see page 3)
Y = 14 mm (0.55 in) for bolts
 - Additional length of bolt thread used for nuts mounting
25 mm (0.98 in) for studs
 - Additional length of bolt thread used for nuts mounting

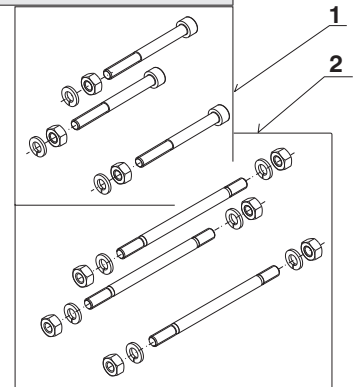

L [mm (in)]	Ordering number / Kit	L [mm (in)]	Ordering number / Kit
1 - BOLTS		2 - STUDS	
45 (1.772)	29204400	199 (7.835)	29207300
60 (2.362)	29204600	203 (7.992)	29207400
75 (2.953)	29204800	209 (8.228)	29207500
85 (3.346)	29205000	219 (8.622)	29207600
100 (3.937)	29205100	224 (8.819)	29207700
2 - STUDS		229 (9.015)	29207800
109 (4.291)	29205300	236 (9.291)	29207900
115 (4.527)	29205400	245 (9.646)	29208000
125 (4.921)	29205500	253 (9.961)	29208100
133 (5.24)	29205600	256 (10.078)	29208300
136 (5.35)	29205700	259 (10.197)	29208400
143 (5.630)	29205800	265 (10.433)	29208500
147 (5.787)	29205900	273 (10.748)	29208600
152 (5.984)	29206000	279 (10.984)	29208700
157 (6.181)	29206200	287 (11.299)	29208800
163 (6.417)	29206300	295 (11.614)	29208900
167 (6.575)	29206400	300 (11.811)	29209000
172 (6.772)	29206900	309 (12.165)	29209100
179 (7.047)	29207000	314 (12.362)	29209200
187 (7.362)	29207100	320 (12.59)	29209300
194 (7.638)	29207200	328 (12.913)	29209400

Note:

Select the bolt or screw length according to the nearest dimension available in the table.

Vertical Assembly Illustrative Figure

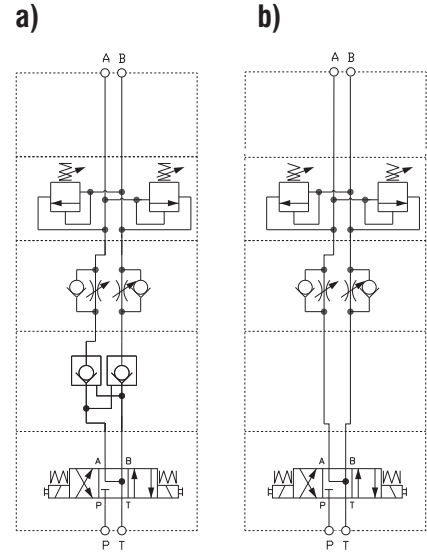
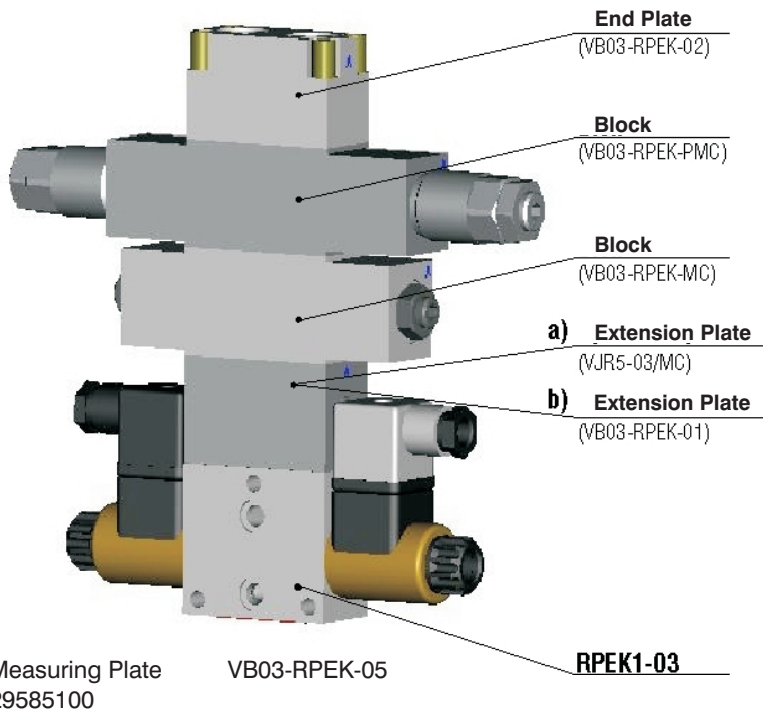

VERTICAL ASSEMBLY

1- 4 Section

Extension Plate

Type	Cavity	Connecting threads	Ordering number	Page	Description (to select the studs)
VB03-RPEK-01			28131500	35	L1=40 mm (1.57 in)

Pilot Operated Check Valve

VJR5-03	Dn 03	Katalog HA 5027		36	L1=40 mm (1.57 in)
---------	-------	-----------------	--	----	--------------------

Vertical Sandwich Plate with Valves

VB03-RPEK-PMC	2/2 - 3/4-16UNF		28672700	37	L1=40 mm (1.57 in)
VSVJ1-03/MC	M12x1		28672500	38	L1=40 mm (1.57 in)
VSVJ1-03/MD	M12x1		28672400	39	L1=40 mm (1.57 in)

Cover Plate - A,B Ports

VB03-RPEK-02		A,B - G1/4	28130400	40	L2=26 mm (1.02 in)
VB03-RPEK-02-S		A,B - SAE 6		40	L2=26 mm (1.02 in)
VB03-RPEK-03		A,B - G1/4 - side	28476200	41	L2=26 mm (1.02 in)
VB03-RPEK-03-S		A,B - SAE 6 - side	29009000	41	L2=26 mm (1.02 in)
VB03-RPEK-04		A,B - G3/8 - side	28672900	41	L2=26 mm (1.02 in)

Measuring Plate - A,B Ports

VB03-RPEK-05		A,B - G1/4	295851000	40	L2=26 mm (1.02 in)
--------------	--	------------	-----------	----	--------------------

Extension Plate

VB03-RPEK-01

28131500

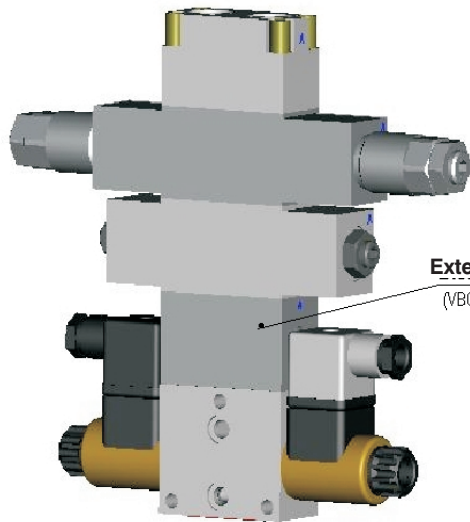

Extension Plate
(VB03-RPEK-01)

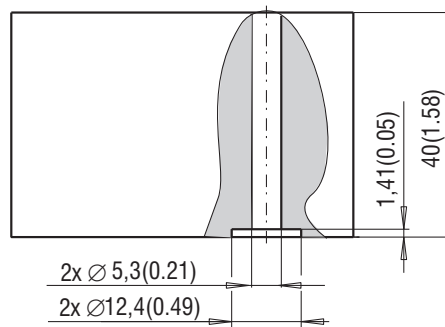
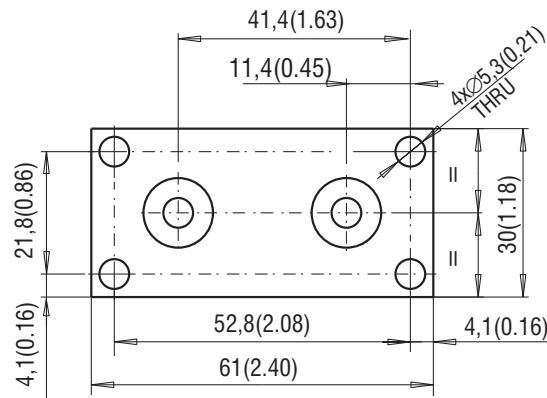
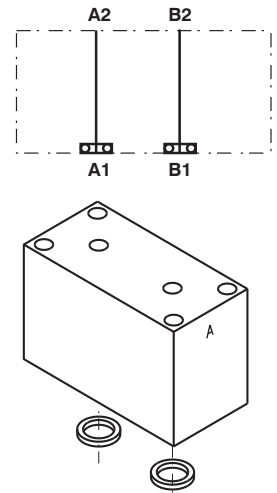
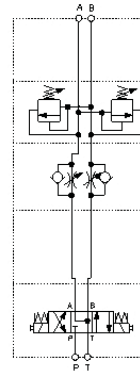

Dimensions in millimeters (inches)

The application of a extension plate is required only in vertical assembly situation in case no Pilot Operated Check valve is used and is required a free space for electrical connectors of RPEK directional valve (see example of assembly in picture).

Name	Type	Port size		Ordering number	Weight [kg (lb)]
		A	B		
Extension Plate+ seals	VB03-RPEK-01	-	-	28131500	0,189 (0.436)

Pilot Operated Check Valve

HA 5027

VJR5-03/MA

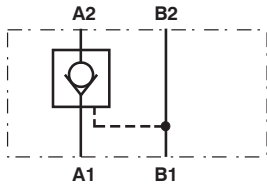

VJR5-03/MB

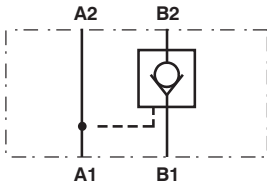

VJR5-03/MC

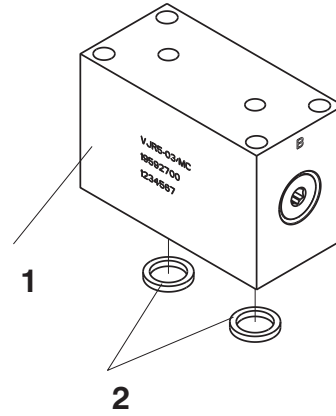
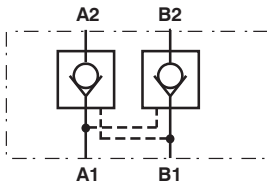

Pos.	Name	Type	Weight [kg (lb)]	Data sheet	Ordering number
1	Hydraulic lock + seals	VJR5-03/Mx	0,2 (0.441)	HA 5027	
2	Spare Seal kit	Square ring	O-ring		
	Standard - NBR70	9,25 x 1,68 (2 pcs.)	4,47 x 1,78 (2 pcs.)		28407200
	Viton	-	9,25 x 1,78 (2 pcs.)		28407300
			4,47 x 1,78 (2 pcs.)		

Valve Dimensions

Dimensions in millimeters (inches)

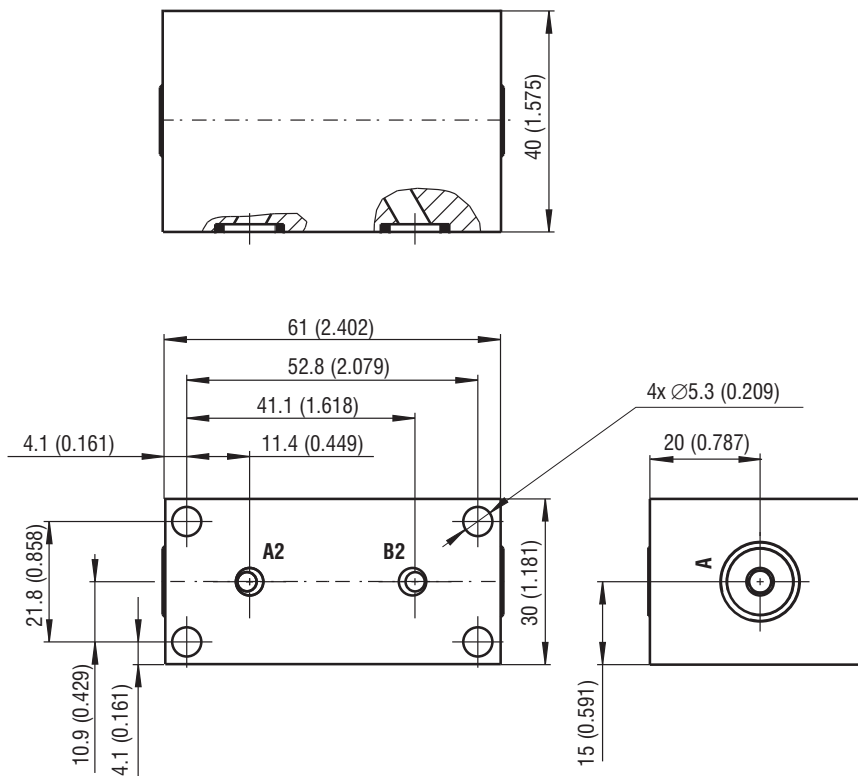

Sandwich Plate

VB03-RPEK-PMx

28672700

1

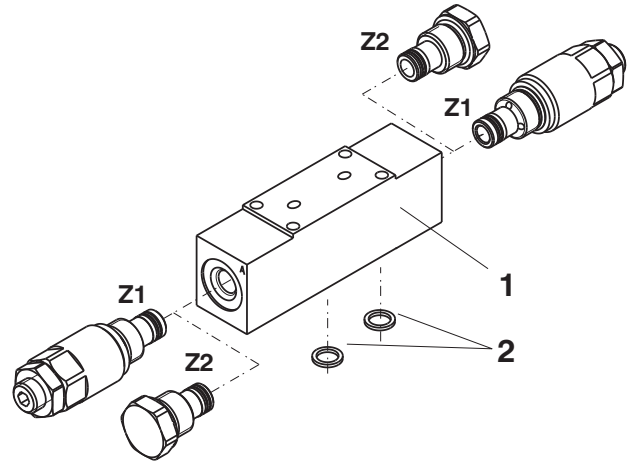
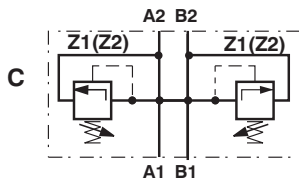
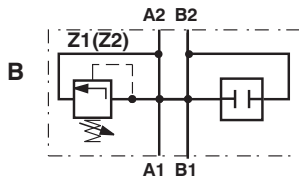
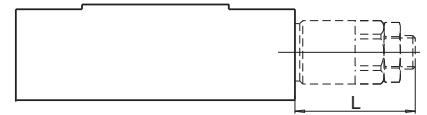
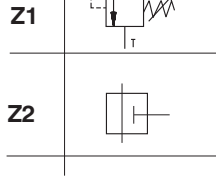
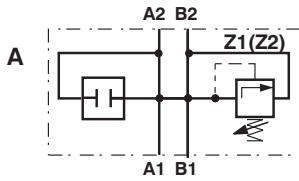

Pos.	Name	Type	Max. L [mm (in)]	Weight [kg (lb)]	Data sheet	Ordering number
1	Sandwich plate +seals	VB03-RPEK-PMx		0,349 (0.769)		28672700
Z1	Pressure valve	SR1A-A2	78 (3.07)		HA 5063	
Z2	Plug 3/4-16UNF		7,5 (0.29)			15960800
Spare Seal kit- Square ring						
2	Standard - NBR70		9,25 x 1,68 (2 pcs.)			15608800
	Viton		9,25 x 1,78 (2 pcs.)			20152400

Valve Dimensions - PMC

Dimensions in millimeters (inches)

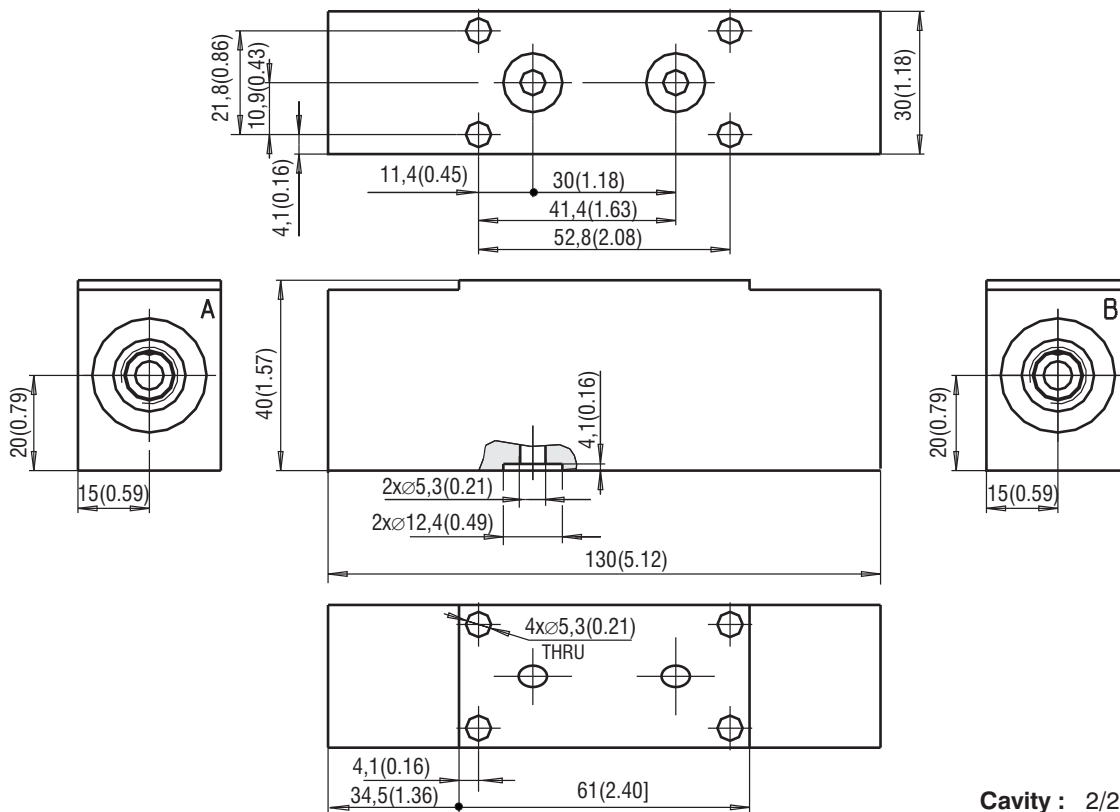

Cavity : 2/2 -3/4/16UNF

Sandwich Plate VB03-RPEK-Mx

28672500

Screw-in Cartridge Throttle Valve with Bypass Check Valve

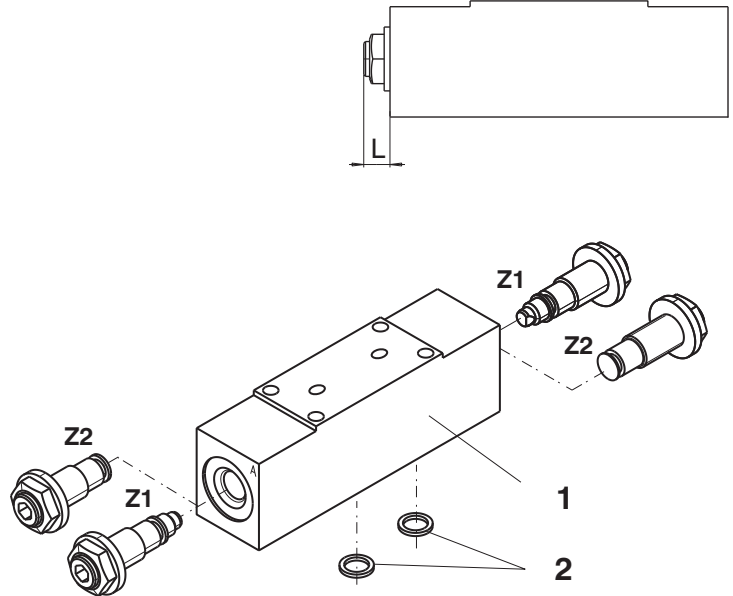
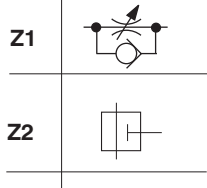
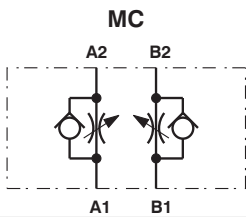
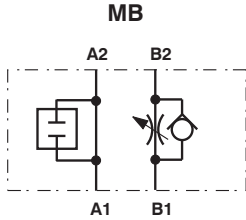
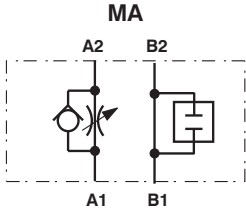

Pos.	Name	Type	Max. L [mm (in)]	Weight [kg (lb)]	Data sheet	Ordering number
1	Sandwich plate+seals	VB03-RPEK-MC		0,361(0.795)		28672500
Z1	Flow valve	VSV2 (only model -1, - J1)	11 (0.43)		HA 5132	
Z2	Plug	VSV/ M12x1	11 (0.43)			22727000
Spare Seal kit- Square ring						
2	Standard - NBR70		9,25 x 1,68 (2 pcs.)			15608800
	Viton		9,25 x 1,78 (2 pcs.)			20152400

Valve Dimensions - MC

Dimensions in millimeters (inches)

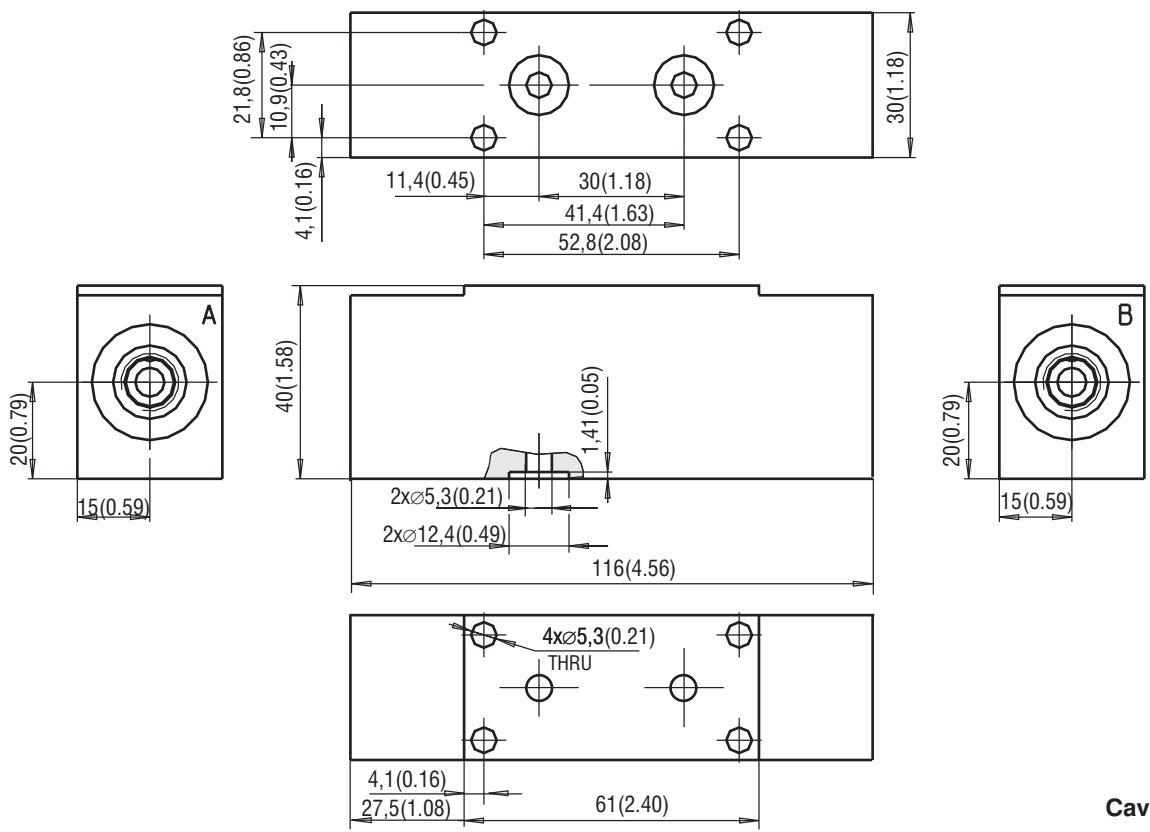

Cavity: M12x1

Sandwich Plate VB03-RPEK-Mx

28672400

1

Screw-in Cartridge Throttle Valve with Bypass Check Valve

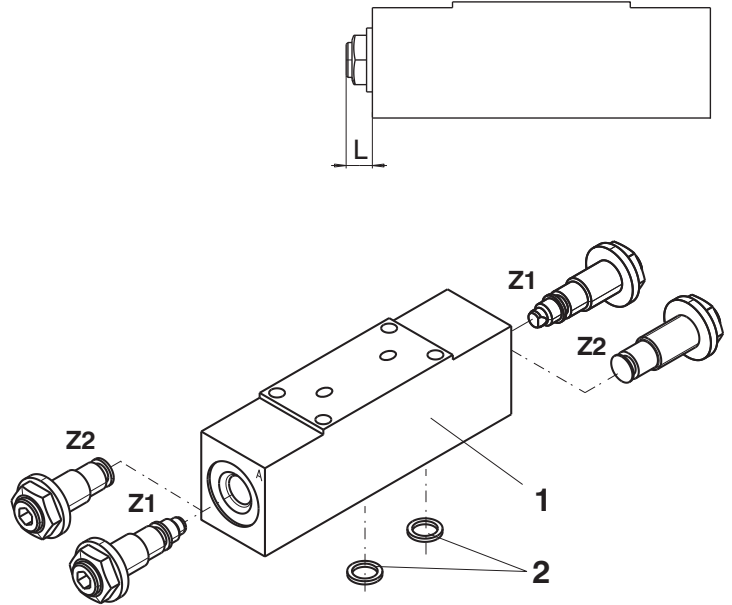
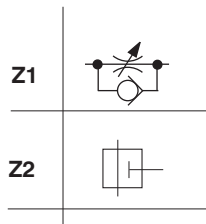
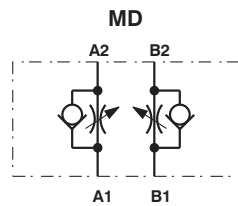
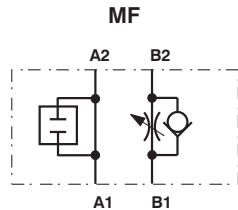
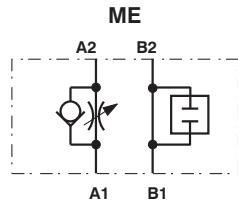

Pos.	Name	Type	Max. L [mm (in)]	Weight [kg (lb)]	Data sheet	Ordering number
1	Sandwich plate +seals	VB03-RPEK-MD		0,361 (0.795)		28672400
Z1	Flow valve	VSV2 (only model -1, - J1)	11 (0.43)		HA 5132	
Z2	Plug	VSV/ M12x1	11 (0.43)			22727000
Spare Seal kit- Square ring						
2	Standard - NBR70		9,25 x 1,68 (2 pcs.)			15608800
	Viton		9,25 x 1,78 (2 pcs.)			20152400

Valve Dimensions - MD

Dimensions in millimeters (inches)

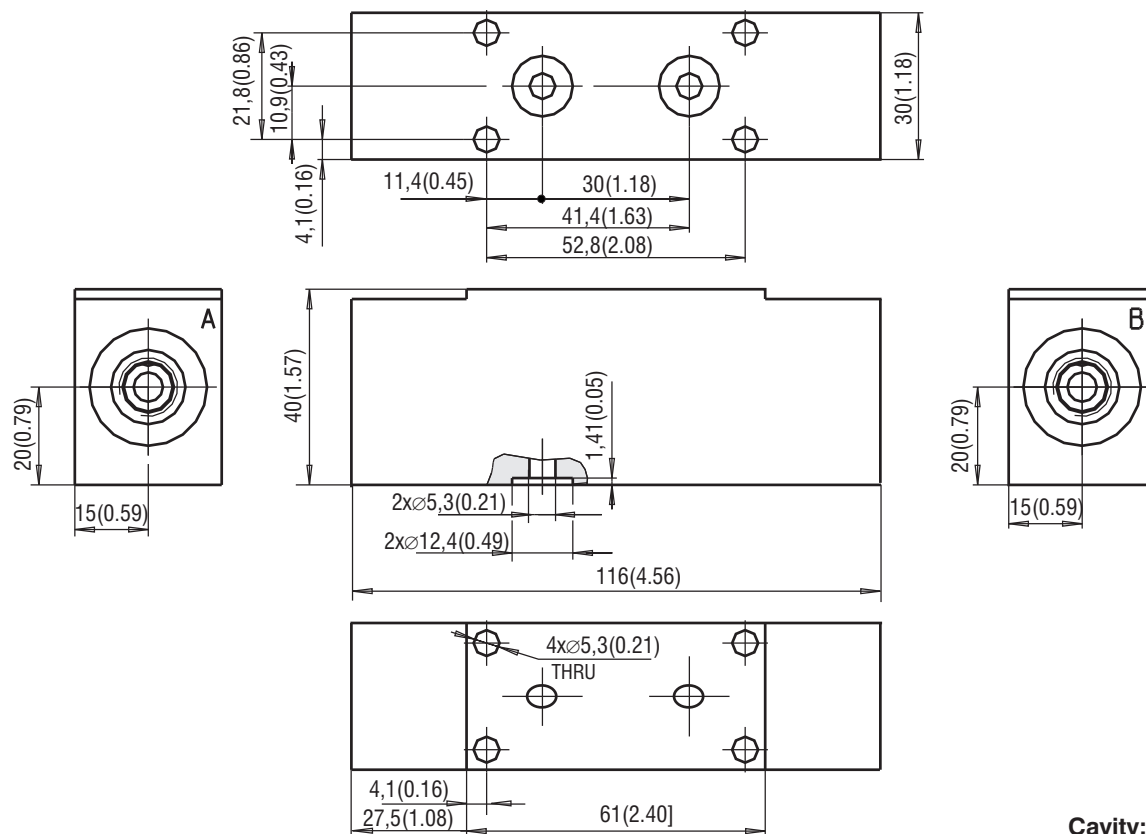

Cavity: M12x1

Cover Plate VB03-RPEK-02- /(S)

28130400/(29008900)

1

VB03-RPEK-02

VB03-RPEK-02-S

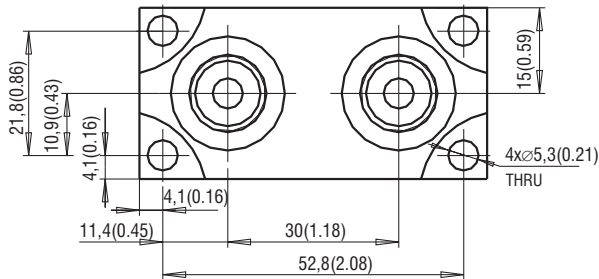
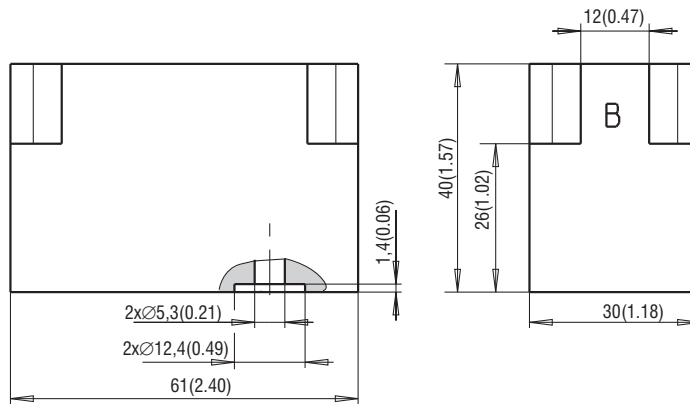
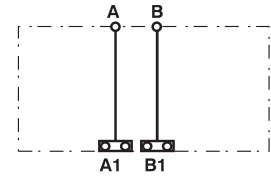
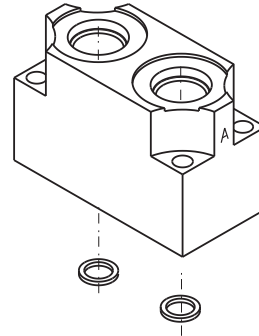
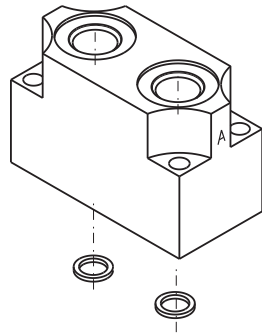

VB03-RPEK-02

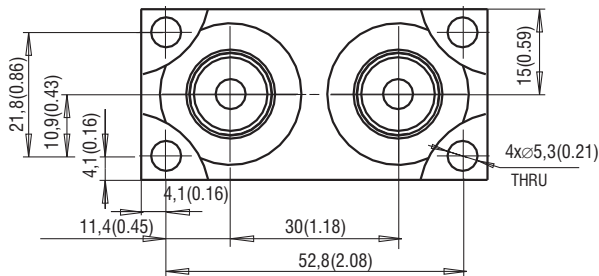

VB03-RPEK-02-S

Dimensions in millimeters (inches)

Connecting threads : A, B ... G1/4 (SAE6)

Name	Type	Port size		Ordering number	Weight [kg (lb)]
		A	B		
Cover plate + seals	VB03-RPEK-02	G1/4	G1/4	28130400	0,172 (0.379)
	VB03-RPEK-02-S	SAE 6	SAE 6	29008900	

Cover Plate

VB03-RPEK-03-/(S)

28476200/(29009000)

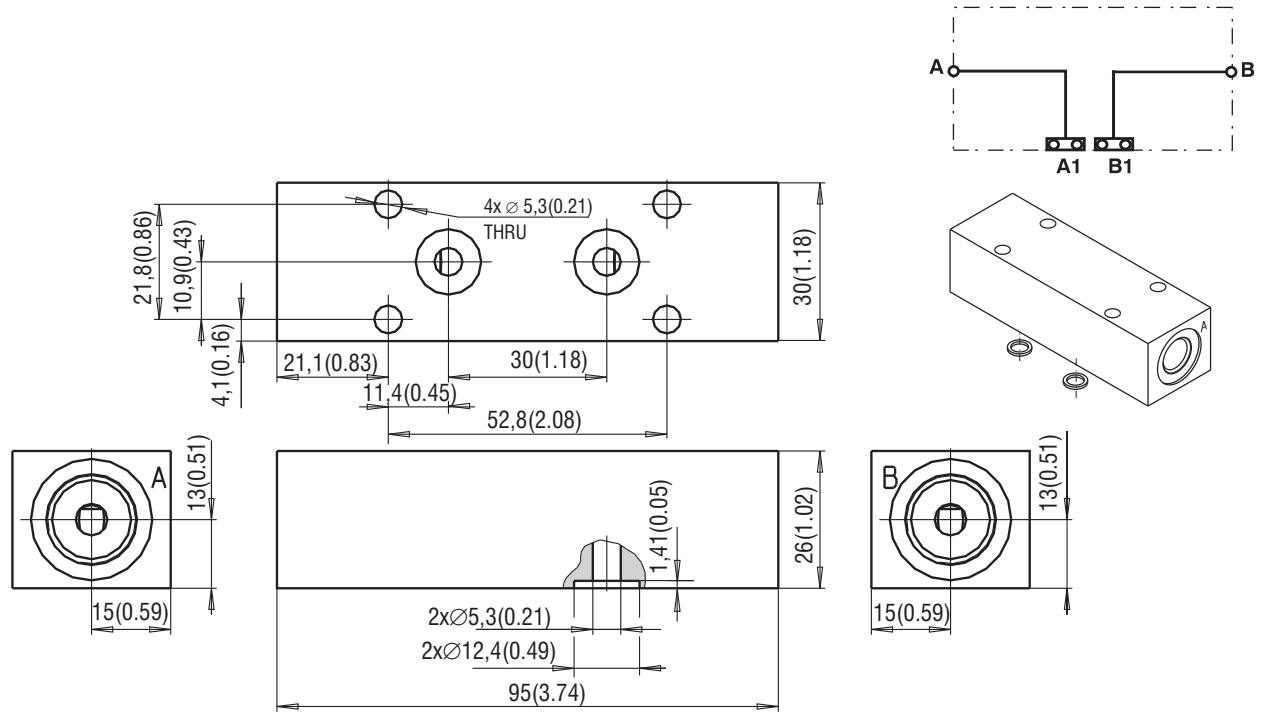

Dimensions in millimeters (inches)
Connecting threads: A, B ... G1/4 (SAE 6)

Cover Plate

VB03-RPEK-04

28672900

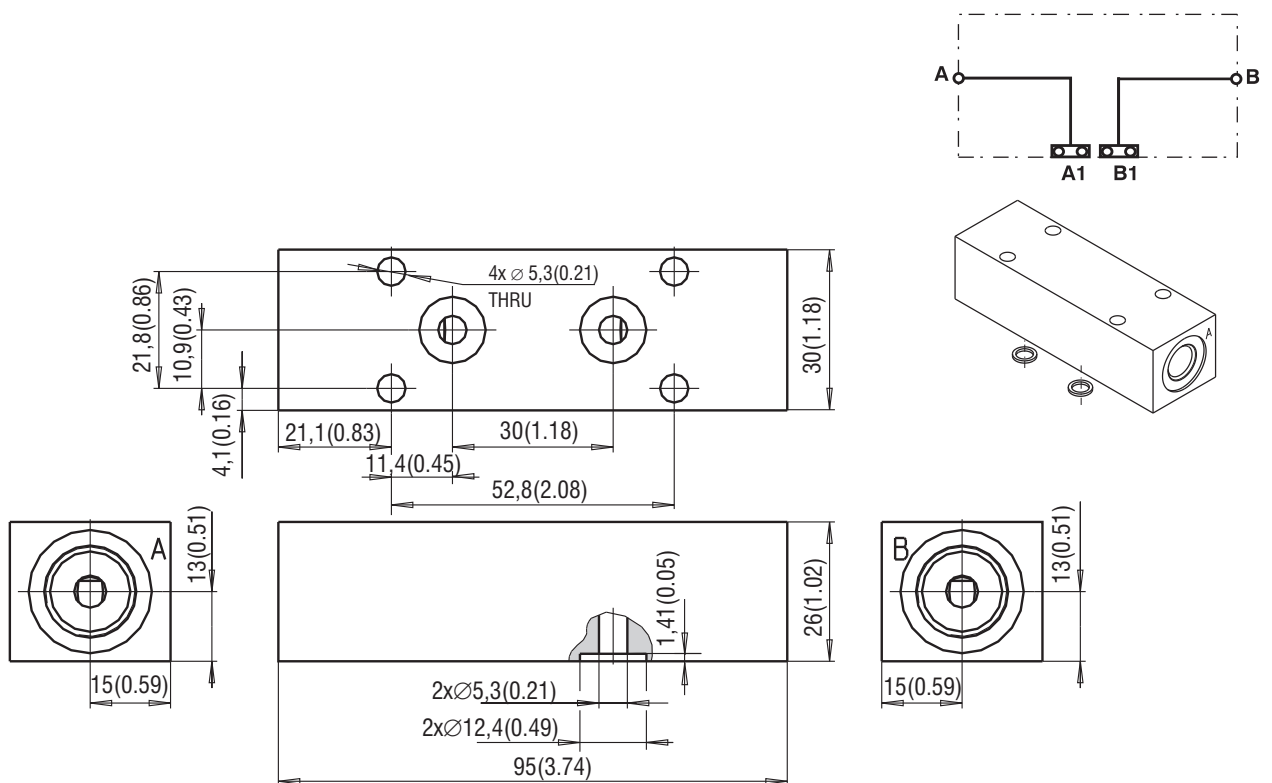

Dimensions in millimeters (inches)
Connecting threads: A, B ... G 3/8

Name	Type	Port size		Ordering number	Weight [kg (lb)]
		A	B		
Cover plate + seals	VB03-RPEK-03	G1/4	G1/4	28476200	0,131 (0.289)
	VB03-RPEK-03-S	SAE 6	SAE 6	29009000	
Cover plate + seals	VB03-RPEK-04	G3/8	G3/8	28672900	0,177 (0.390)

Measuring Plate

VB03-RPEK-05

29585100

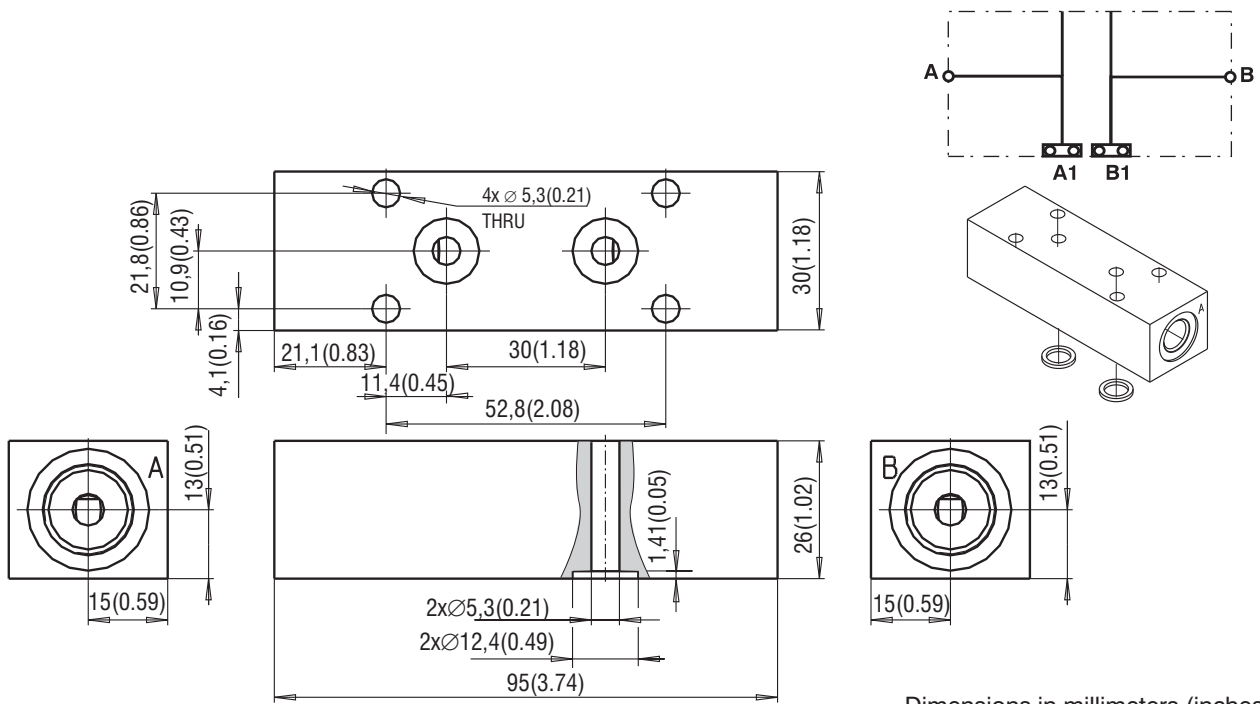

Dimensions in millimeters (inches)

Connecting threads: A, B ... G1/4

Name	Type	Port size		Ordering number	Weight [kg (lb)]
		A	B		
Measuring plate + seals	VB03-RPEK-05	G1/4	G1/4	29585100	0,177 (0.390)

Spare Parts - Plates

Seal kit - Square ring

Name	Dimensions, number	Ordering number
Standard - NBR70	9,25 x 1,68 (2 pcs.)	15608800
Viton	9,25 x 1,78 (2 pcs.)	20152400

M5 BOLTS LENGTH – for Vertical Assembly ($M_u - 5(3.69)$ [Nm (lbf-ft)])

$$L = (L1 \times X) + L2 + 9$$

L = total length**L1** = 40 mm (1.57 in) (Vertical plates with height 40 mm (1.57 in))**L2** = 26 mm (1.02 in) (Vertical plates with height 26 mm (1.02 in))**X** = Number of plates of the given width (see page 3)

L [mm (in)]	Ordering number/Kit (4x bolts)
75 (2.952)	29245200
115 (4.527)	29245300
155 (6.102)	29245400

Note:

Select the bolt or screw length according to the nearest dimension available in the table.

ARGO-HYTOS s.r.o CZ - 543 15 Vrchlabí
 tel.: 499 403111, fax: 499 403421
 e-mail: sales.cz@argo-hytos.com
 www.argo-hytos.com

- 4/3-, 4/2- way directional control valves with solenoid control
- Solenoids can be turned around their axis to any position
- Push button manual override
- Installation dimensions according to DIN 24 340 / ISO 4401 / CETOP RP121-H
- Subplates see data sheet HA 0002
- CSA Upon request

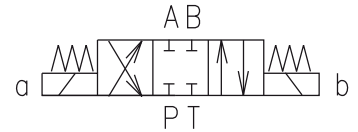

Functional Description

The RPE3-04 directional control valves consist of cast iron housing (1), control spool (5) with two centering springs (4) and operating solenoids (2, 3).

The three-position directional valves are fitted with two solenoids and two springs. Two-position directional valves have either one solenoid and one return spring or two solenoids and a detent assembly.

The operating solenoids are DC solenoids supplied through connectors A, B (6, 7). For AC supply the solenoids are provided with a rectifiers which are

integrated in the DIN connector socket as part of the solenoid. By loosening the nut (8), the solenoid can be turned around its axis up to 360°.

In the case of solenoid malfunction or power failure, the spool of the valve can be repositioned by manual override (9), provided the pressure in the T-port does not exceed 25 bar (363 PSI).

The valve housing (1) is phosphate coated and the solenoids (2, 3) are zinc coated.

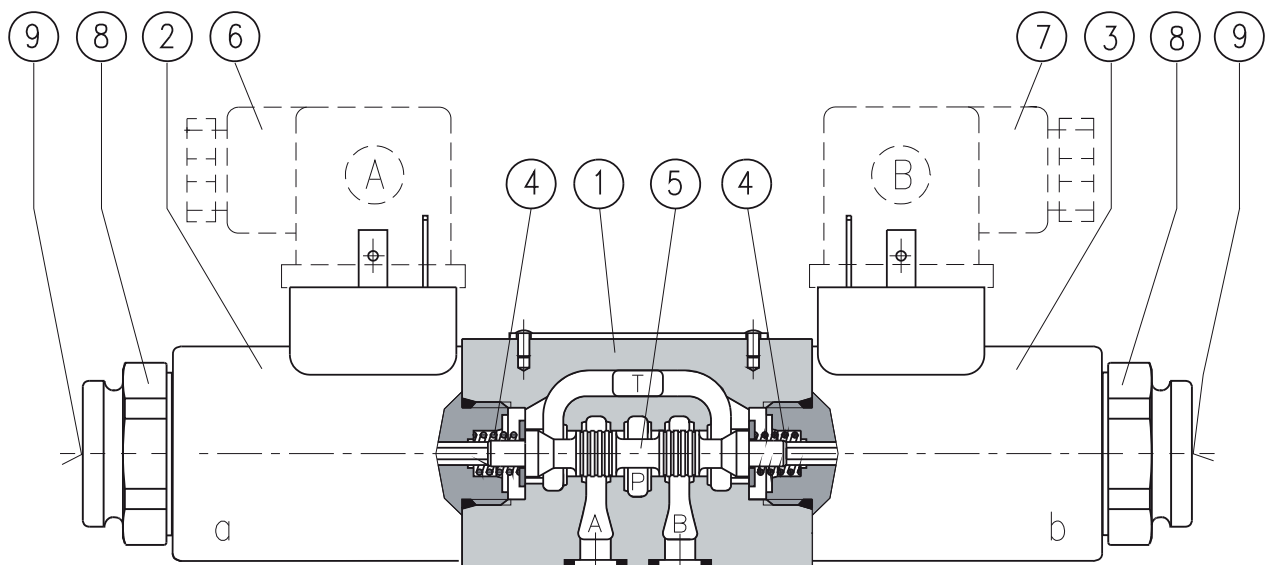

Ordering Code

RPE3-04 /

**Solenoid Operated
Directional Control Valve**

**no designation
V**

Seals
NBR
FPM (Viton)

Nominal size **04(D02)**

no designation
D1
D2
D3
D4
D5

Orifice in P-Port
without orifice
Ø0.8 mm (0.031 in)
Ø1.0 mm (0.039 in)
Ø1.2 mm (0.047 in)
Ø1.5 mm (0.059 in)
Ø0.7 mm (0.027 in)

Number of valve positions
two positions **2**
three positions **3**

no designation
N2

Manual override
standard
covered with rubber protective boot

Functional symbols
see the table functional symbols

Rated supply voltage of solenoids
(at the coil terminals)

12 V DC / 2.41 A	Ⓢ	01200
14 V DC / 1.66 A	Ⓢ	01400
21 V DC / 1.14 A		02100
24 V DC / 1.16 A		02400
42 V DC / 0.59 A		04200
48 V DC / 0.56 A		04800
60 V DC / 0.41 A		06000
102 V DC / 0.24 A		10200
205 V DC / 0.12 A		20500
24 V AC / 1.44 A / 50 (60) Hz	Ⓢ	02450
115V AC / 0.26 A / 50 (60) Hz	Ⓢ	11550
230 V AC / 0.14 A / 50 (60) Hz		23050

***Electrical connector, EN 1745301-803**
no designation
K1
K2

K3
K4

K5

without connector
connector without rectifier
connector without rectifier with LED
and quenching diode
connector with rectifier
connector with rectifier with LED
and quenching diode
connector without rectifier

E1
E2

E3
E4
E5

Type of solenoid coil
with terminal for the connector, EN 1745301-803
with terminal for the connector, EN 1745301-803
and quenching diode
with AMP-Junior-Timer-connector
with AMP-Junior-Timer-connector and quenching diode
with integrated rectifier and with terminal
for the connector, EN 1745301-803

The AC coils correspond with E5 type.

Other coils on demand see catalog HA 8007

CSA Upon request Ⓢ

Note: Electrical connectors have to be ordered separately. See see pages 6 and 8.

Recommended solenoid coils used with electrical connector with rectifiers - type designation K3, K4

Rated supply source voltage (permissible rated voltage variation ±10 %)	Type designation of the solenoid voltage
24 V AC / 1.44 A / 50 (60) Hz	02100
115 V AC / 0.26 A / 50 (60) Hz	10200
230 V AC / 0.14 A / 50 (60) Hz	20500

**FOR PREFERRED TYPES SEE BOLD TYPING IN ORDERING CODE, FUNCTIONAL SYMBOLS
AND TABLE OF PREFERRED TYPES ON PAGE 8**

Technical Data

Valve size	mm (US)	04 (D 02)
Maximum flow	L/min (GPM)	see p-Q characteristics
Maximum operating pressure at ports P, A, B	bar (PSI)	320 (4600)
Maximum operating pressure at port T	bar (PSI)	210 (3045)
Pressure drop	bar (PSI)	see Δp -Q characteristics
Hydraulic fluid		Hydraulic oils of power classes (HL, HLP) to DIN 51524
Fluid temperature range (NBR / Viton)	°C (°F)	-30 ... +80 (-22 ... +176) / -20 ... +80 (-4 ... +176)
Ambient temperature, max.	°C (°F)	+50 (122)
Viscosity range	mm ² /s (SUS)	20 ... 400 (98 ... 1840)
Maximum degree of fluid contamination		Class 21/18/15 to ISO 4406
Maximum allowable voltage variation	%	AC: ± 10 DC: ± 10
Maximum switching frequency	h ⁻¹	15 000
Switching time, ON; at $v = 156$ SUS (32 mm ² /s)	ms	30 ... 50
Switching time, OFF; at $v = 156$ SUS (32 mm ² /s)	ms	AC: 70 ... 100 DC: 30 ... 50
Duty cycle	%	100
Service life	cycles	10 ⁷
Enclosure type to EN 60 529		IP 65
Weight - valve with 1 solenoid - valve with 2 solenoid	kg (lbs)	0.9 (1.978) 1.25 (2.747)
Mounting position		unrestricted

Spool Symbols

Type	Symbol	Crossover	Type	Symbol	Crossover
Z11			P51		
C11			Y51		
H11			C51		
P11			Z51		
Y11			Z11		
L21			X11		
B11			C11		
Y71			H11		
R11			J15		
R21			J75		
A51					

p-Q Characteristic

Measured at $v = 32 \text{ mm}^2/\text{s}$ (156 SUS)

Operating limits for maximum hydraulic power transferred by the directional valve. For respective spool type - see spool symbols.

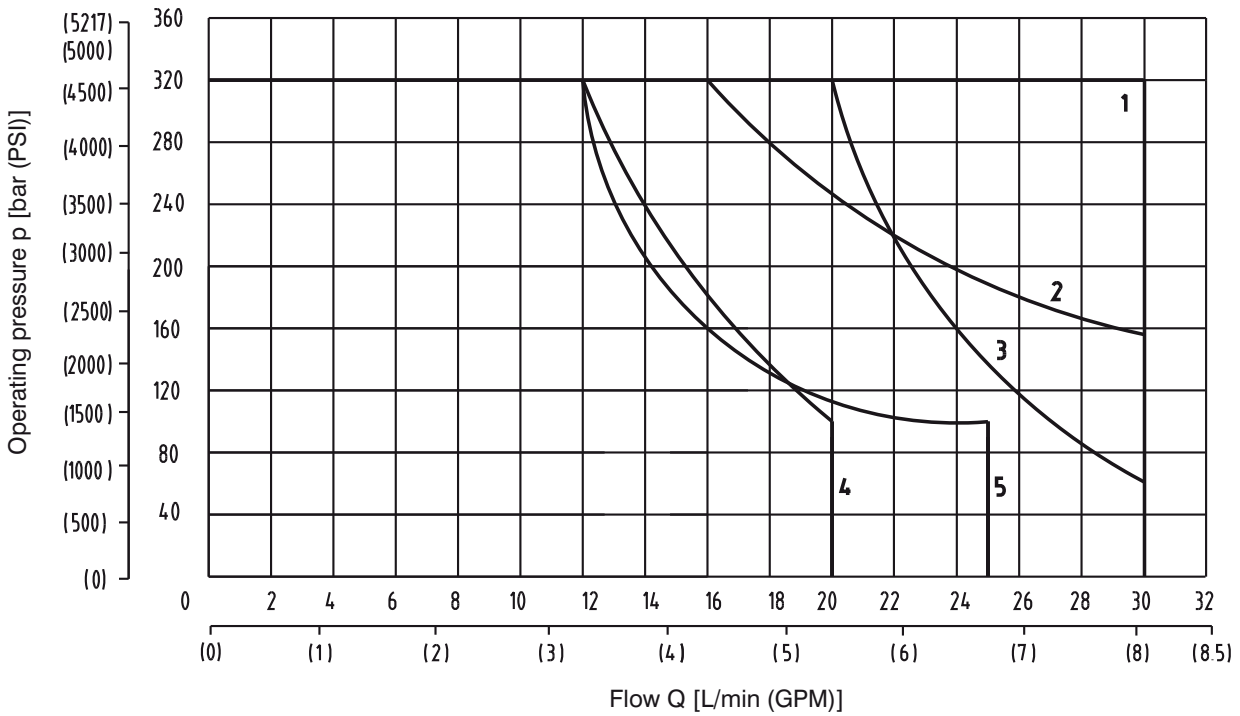

Z11	C11	H11	P11	Y11	L21	B11	Y71	R11	R21	A51	P51	Y51	C51	Z51	X11	J15	J75
1	2	1	1	1	4	1	5	1	3	4	1	1	2	1	1	1	4

Δp-Q Characteristic

Measured at $v = 32 \text{ mm}^2/\text{s}$ (156 SUS)

Pressure drop Δp related to flow rate.

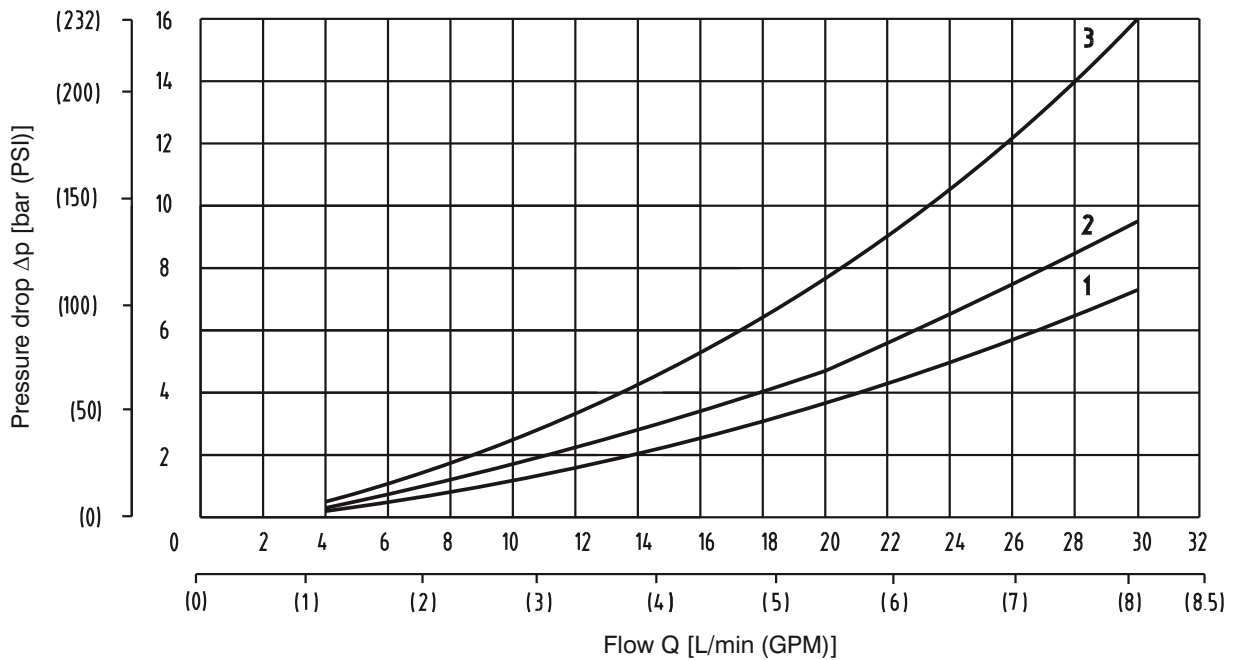

	Z11	C11	H11	P11	Y11	L21	B11	Y71	R11	R21	A51	P51	Y51	C51	Z51	X11	J15	J75
P-A	1	3	1	1	1	1	1	2	2	2	1			3		2	2	1
P-B	1	3	1	1	1	1	1		2	2	1	1	1		1	2	2	1
A-T	1	3	1	1	1	1	1	2	2	2		1	1		1	2	2	
B-T	1	3	1	1	1	1	1	1	2	2				3		2	2	
P-T		2	2											2				

Valve Dimensions

Dimensions in millimeters (inches)

1

Valve with two solenoids

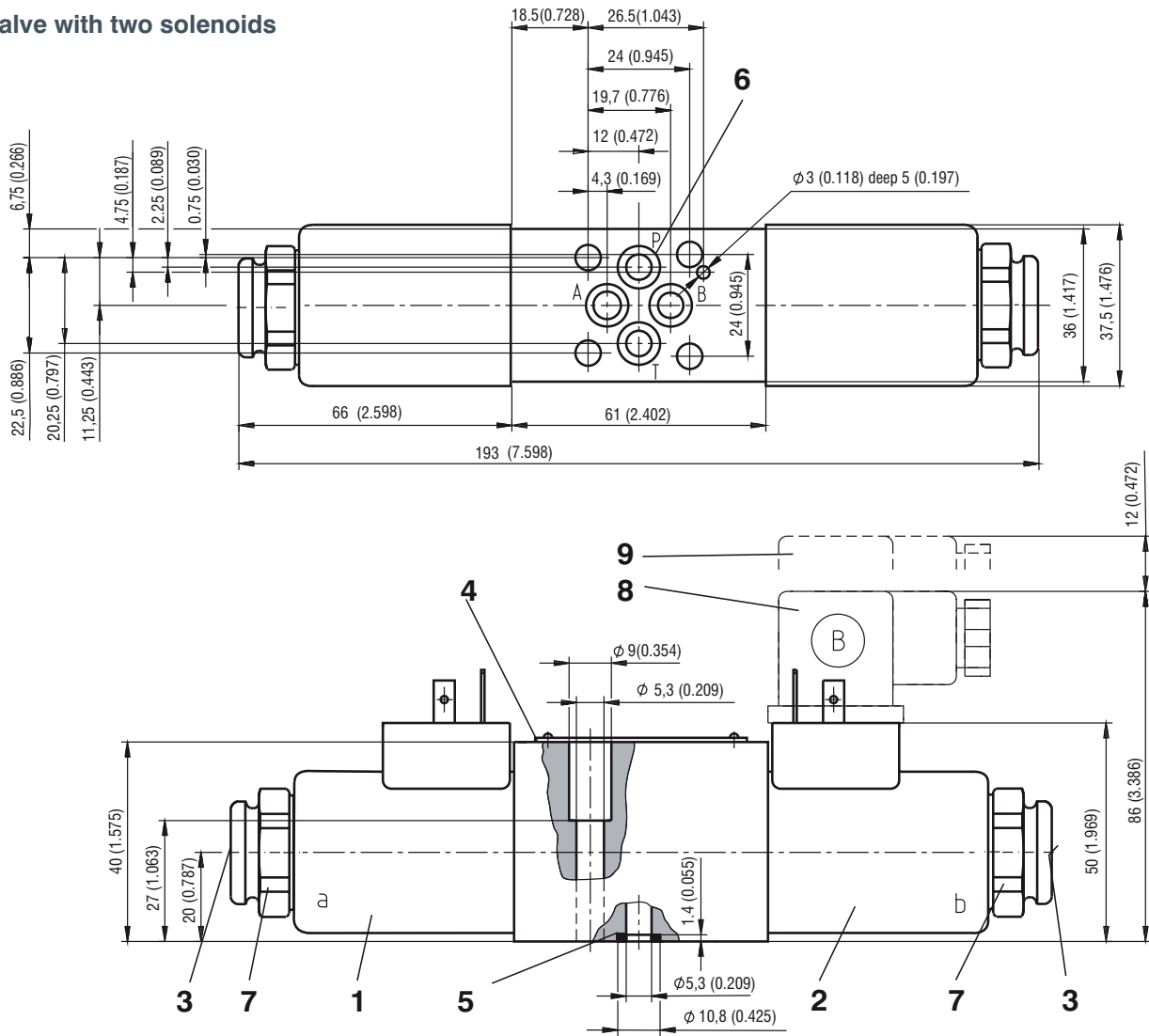

- 1 Solenoid a
[(Nut torque 2.21 ft-lbs. (3Nm))]
- 2 Solenoid b
[(Nut torque 2.21 ft-lbs. (3Nm))]
- 3 Manual override
- 4 Name plate
- 5 Square ring 7.65 x 1.68 (4 pcs.)
supplied with valve
- 6 4 mounting holes
- 7 Retaining nut of the solenoid
- 8 Electrical connector,
DIN EN1745301-803
- 9 Space required to remove connector

Valve with one solenoid a

Spool symbols R11, R21, A51, P51,
Y51, C51, Z51

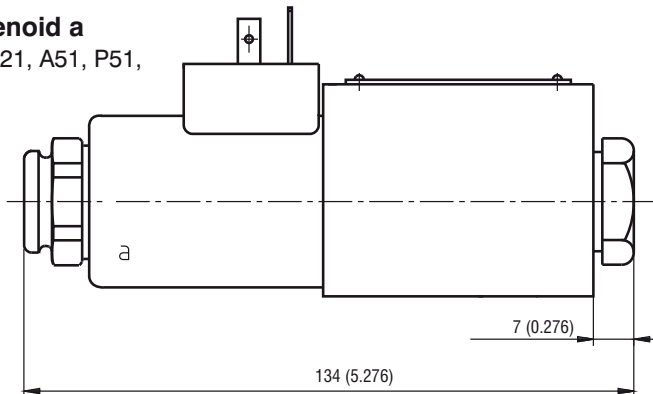

Valve with one solenoid b

Spool symbols Z11, X11, C11, H11

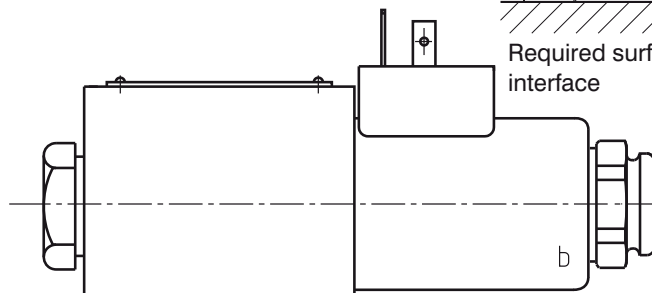

	0.0004 / 4.0 [in]
	0.01 / 100 [mm]

0,8(32) Rmax 6,3(248) [µm(µin)]

Required surface finish of interface

Type of the Solenoid Coil

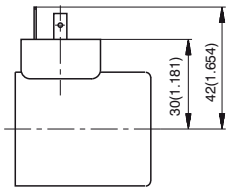
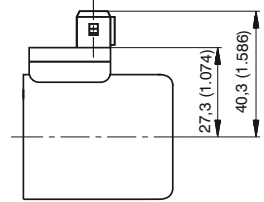
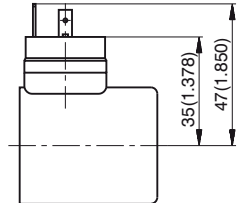
Type	Dimensions	Description
E1		Solenoid coil with terminal for the electrical connector, EN 1745301-803
E2		Solenoid coil with integrated quenching diode (bipolar transistor diode) and terminal for the electrical connector, EN 1745301-803
E3		Solenoid coil with terminal for AMP-Junior-Timer electrical connector.
E4		Solenoid coil with integrated quenching diode (bipolar transistor diode) and terminal for AMP-Junior-Timer electrical connector.
E5		Solenoid coil with integrated rectifier and terminal for the electrical connector, EN 1745301-803

Electrical connector, EN1745301-803

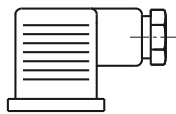
K1	Connector B (black)	without rectifier - M16x1.5 (bushing bore Ø 6-8 mm)	230 V AC/DC	
	Connector A (grey)			
K5	Connector B (black)	without rectifier - M16x1.5 (bushing bore Ø 4-6 mm)	230 V AC/DC	
	Connector A (grey)			
K2	Connector B (black)	without rectifier with LED and quenching diode - M16x1.5 (bushing bore Ø 6-8 mm)	12 ... 24 V DC	
	Connector A (grey)			
K3	Connector B (black)	with rectifier - M16x1.5 (bushing bore Ø 6-8 mm)	230 V AC	
	Connector A (grey)			
K4	Connector B (black)	with rectifier with LED and quenching diode - M16x1.5 (bushing bore Ø 6-8 mm)	230 V AC	

Manual override

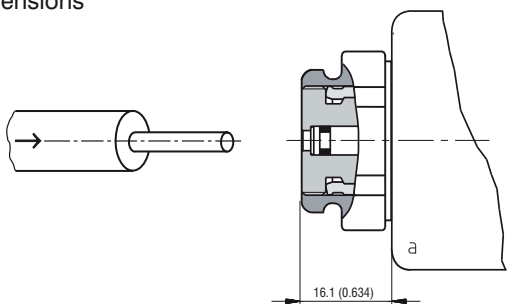
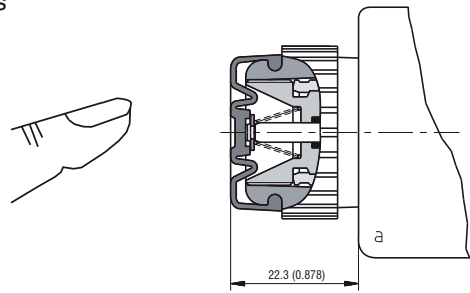
STANDARD	RUBBER BOOT
<p>no designation Dimensions</p>  <p>Standard model of manual override. Standard retaining nut of the solenoid.</p>	<p>Type N2 Dimensions</p>  <p>Manual override protected by rubber boot.</p>

Orifice in P-Port

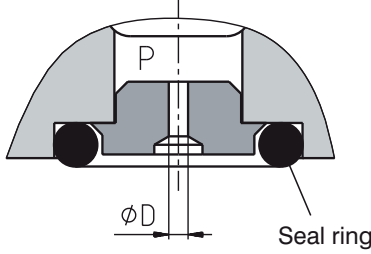
Type	∅D mm (inch)		P-port orifices limits the flow into the directional control valve. Attention: When the orifice in P port is additionally mounted the standard used square ring NBR is replaced with O-ring from Viton.
D1	0,8 (0.032)		
D2	1,0 (0.040)		
D3	1,2 (0.047)		
D4	1,5 (0.059)		
D5	0,7 (0.028)		

Spare Parts

- 1 Solenoid coil
- 2 Retaining nut with seal
- 3 Electrical connector
- 4 Orifice in P-port with seal
- 5 Seal kit
- 6 Mounting bolts

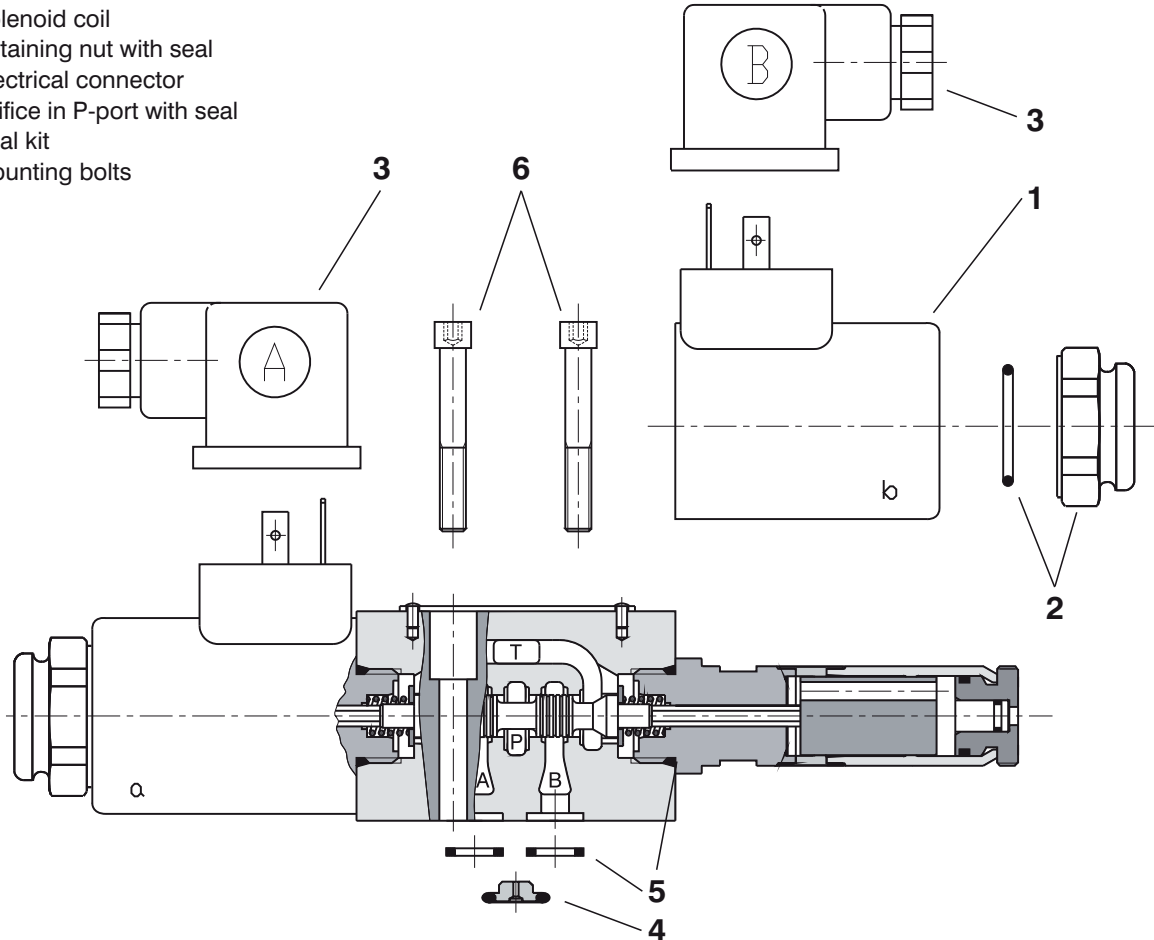

Solenoid coil

Type designation	Type of the coil				
	E1	E2	E3	E4	E5
	Ordering number				
01200	27316600	27631400	27330200	27631600	
*01200	24140700				
02400	27316700	27632400	27449700	27633400	
*02400	24140800				
20500	27382400	-	-	-	
23050					27449900
*23050					24141000

Solenoid retaining nut with seal

Type of the nut	Seal ring	Ordering number
Standard nut	18 x 1.5	15874500
Nut with rubber boot		15874800

* CSA Upon request 

Electrical connector, EN 175301-803			
Type designation	Connector A grey		Connector B black
	Ordering number		
K1	16202200		16202100
K5	16202600		16202500
K2	16202800		16202700
K3	16202400		16202300
K4	16203000		16202900

Orifice in P-Port			
Type designation	∅D mm (in)	Seal ring	Ordering number
D1	0.8 (0.031)	7.65 x 1.78	15874000
D2	1.0 (0.039)		15874100
D3	1.2 (0.047)		15874200
D4	1.5 (0.059)		15874300
D5	0.7 (0.027)		15874900

Seal kit			
Type	Dimensions, number		Ordering number
	Square ring	O-ring	
Standard NBR70	7.65 x 1.68 (4 pcs.)	16 x 2 (2 pcs.)	15873800
Viton	7.65 x 1.78 (4 pcs.)	16 x 2 (2 pcs.)	15874400

Mounting bolts			
Dimensions, number		Tightening torque	Ordering number
M5 x 35 DIN 912-10.9 (4 pcs.)		5 Nm (3.68 lbf . ft)	15874600

Preferred Types of Valves

Type	Ordering number	Type	Ordering number
RPE3-042Z11/01200E1	16711100	RPE3-042R11/02400E1	15855300
RPE3-043Z11/01200E1	15849000	RPE3-042R21/02400E1	15855700
RPE3-043C11/01200E1	15849900	RPE3-042A51/02400E1	15855200
RPE3-043H11/01200E1	15850300	RPE3-042Y51/02400E1	15855100
RPE3-043Y11/01200E1	15850500	RPE3-042J15/02400E1	15856600
RPE3-042R11/01200E1	15851900	RPE3-042Z11/23050E5	21714900
RPE3-042R21/01200E1	16711000	RPE3-043Z11/23050E5	16712400
RPE3-042A51/01200E1	16710900	RPE3-043C11/23050E5	16712700
RPE3-042Y51/01200E1	15851800	RPE3-043H11/23050E5	15858800
RPE3-042J15/01200E1	16711400	RPE3-043Y11/23050E5	16712500
RPE3-042Z11/02400E1	15855900	RPE3-042R11/23050E5	15859100
RPE3-043Z11/02400E1	15852200	RPE3-042R21/23050E5	21764800
RPE3-043C11/02400E1	15852800	RPE3-042A51/23050E5	16712600
RPE3-043H11/02400E1	15853200	RPE3-042Y51/23050E5	21785500
RPE3-043Y11/02400E1	15853600	RPE3-042J15/23050E5	21785600

Caution!

- When the distributor contains two electromagnets any of the two electromagnets can be switched on only after the other one switches off. The electromagnets switching time on distributors with locking arrangement must not be shorter than 60 ms.
- Distributors with other interconnections than those shown in the catalogue can be supplied on request.
- The packaging foil can be recycled
- The transport base plate can be returned to the manufacturer.
- Mounting screws M5 x 35 DIN 912-10.9 or bolts must be ordered separately.
The screws tightening torque is 5 Nm (3.68 lbf . ft).
- The mentioned data only serve to describe the product and in no case are to be understood in terms of law as guaranteed characteristics.

ARGO-HYTOS s.r.o. CZ - 543 15 Vrchlaví
Tel.: +420-499-403 111
E-mail: info.cz@argo-hytos.com
www.argo-hytos.com

Size 06 • p_{max} 250 bar (3626 PSI) • Q_{max} 50 L/min (13.2 GPM)

- 4/3 - and 4/2- way directional control valve
- Solenoid with removable coils - electrical connector can be rotated in direction by 90°
- Push button manual override
- Installation dimensions to DIN 24 340 / ISO 4401 / CETOP RP121-H
- Subplates see datasheet HA 0002

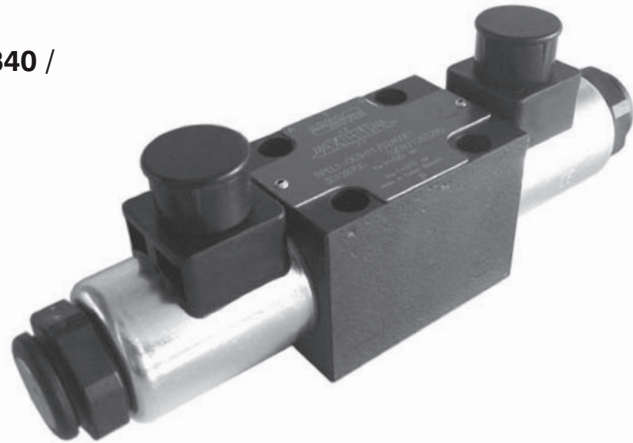
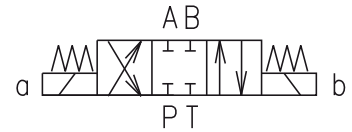

Functional Description

The RPEL1 directional control valves consist of housing (1), a control spool (5) with two centering springs (4) and cylindrical operating solenoids (2, 3).

The three-position directional control valves are fitted with two solenoids and two springs. Two-position directional control valves have either one solenoid and one return spring.

The operating solenoids are DC solenoids. The connectors (6, 7) can be turned by 90°. By loosening the

nut (8), solenoids can be turned around the actuator axis.

In the case of solenoid malfunction or power failure, the spool of the valve can be shifted by manual override (9), provided the pressure in T-port does not exceed 25 bar.

The basic surface treatment of the valve housing (1) is phosphate coated and the solenoids (2, 3) are zinc coated.

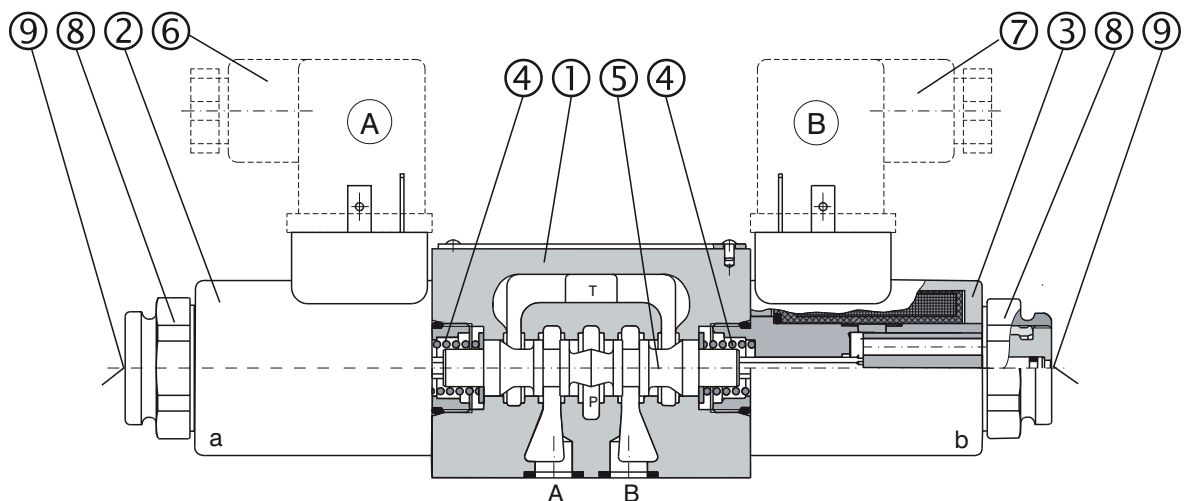

Ordering Code

RPEL1-06 /

**Directional Control Valve
Solenoid Operated**

Nominal size

Number of operating positions

two positions
three positions

2
3

Spool symbols

see the table Spool symbols

Rated supply voltage of solenoids

(at the coil terminals)

12 V DC / 2.41 A

24 V DC / 1.16 A

Other voltage on request.

01200

02400

no designation

M2

Manual override

standard
covered with rubber boot

E1

E2

E3

E4

E12

E13

Type of the solenoid coil

with the connector to EN 1745301-803-A

with the integrated quenching diode and

the connector to EN 1745301-803-A

with the connector AMP-Junior-Timer 2 PIN

with integrated quenching diode and

the connector AMP-Junior-Timer 2 PIN

with the connector Deutsch DT04-2P

with integrated quenching diode and

the connector Deutsch DT04-2P

**For selection of the solenoid coil and the terminal box
type use catalogue HA 8007.**

Technical Data

Nominal size	mm (US)	06 (03)
Maximum flow	L/min (GPM)	see p-Q characteristics
Max. operating pressure at porte P, A, B	bar (PSI)	250 (3626)
Max. operating pressure at port T	bar (PSI)	100 (1450)
Pressure drop	bar (PSI)	see Δp -Q characteristics
Hydraulic fluid		Hydraulic oils of power classes (HL, HLP) to DIN 51524
Fluid temperature range for NBR seals	°C (°F)	-30 ... +80 (-22... +176)
Ambient temperature, max.	°C (°F)	up to +50 (122)
Viscosity range	mm ² /s (SUS)	20 ... 400 (98... 1840)
Maximum degree of fluid contamination		Class 21/18/15 to ISO 4406
Max. allowable voltage variation	%	±10
Max. switching frequency	1/h	10 000
Switching time, on: at v=32 mm ² /s (156 SUS)	ms	30 ... 50
Switching time, off: at v=32 mm ² /s (156 SUS)	ms	10 ... 50
Duty cycle	%	100
Service life	cycles	10 ⁶
Type of protection to EN 60 529	see connector definition	IP 65, IP 67, IP 69K according to the selected design coils*
Weight - valve with 1 solenoid	kg (lbs)	1.4 (3.1)
- valve with 2 solenoids		1.6 (3.5)
Mounting position		unrestricted

*That degree of protection only applies with a properly attached connector plug

Spool Symbols

Designation	Symbol	Interposition	Designation	Symbol	Interposition
Z11			Z51		
C11			H51		
H11			Z11		
Y11			X11		
L21			C11		
R11			H11		
Y51			Y11		
C51					

p-Q Characteristics

Measured at $v = 32 \text{ mm}^2/\text{s}$ (156 SUS) and $t = 40 \text{ }^\circ\text{C}$ (104 $^\circ\text{F}$)

Operating limits for maximum hydraulic power transferred by the directional valve.

Z11	2	Z51	2
C11	4	C51	4
H11	1	H51	1
R11	1	Y51	3
Y11	3	L21	5
X11	1		

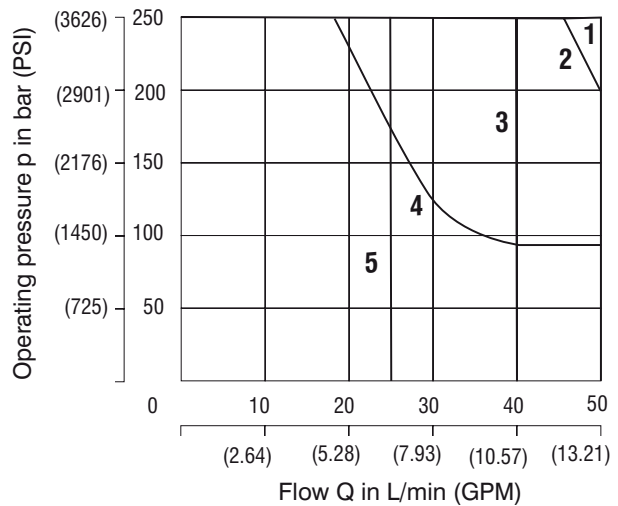

Δp -Q Characteristics

Measured at $v = 32 \text{ mm}^2/\text{s}$ (156 SUS) and $t = 40 \text{ }^\circ\text{C}$ (104 $^\circ\text{F}$)

Pressure drop Δp related to flow rate.

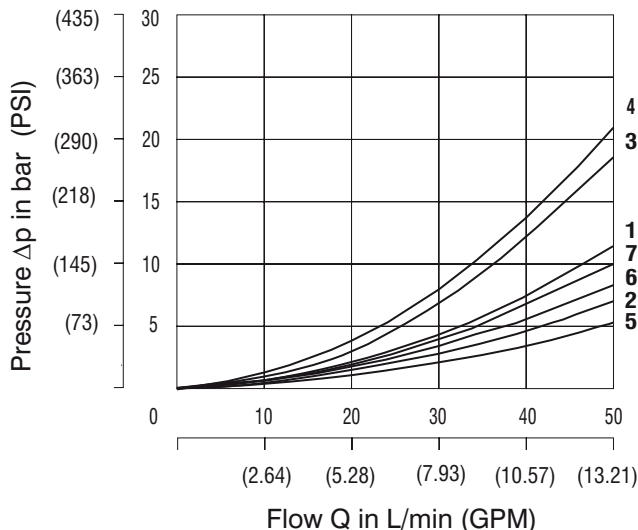

	P-A	P-B	A-T	B-T	P-T
Z11	1	1	1	1	
C11	4	4	4	4	7
H11	5	5	5	5	
Y11	6	6	5	5	
L21	5	6	5	6	4
R11	2	3	3	2	
X11	3	2	2	3	
Z51		1	1		
C51	4			4	7
H51		5	5		
Y51		6	5		

Type of the Solenoid Coil

Dimensions in millimeters (inches)

Designation	Dimensional sketch	Description
E1		Solenoid coil with the connector to EN 1745301-803-A Type of protection to EN 60 529 - IP 65
E2		Solenoid coil with the integrated quenching diode (bipolar transil diode) and the connector to EN 1745301-803-A Type of protection to EN 60 529 - IP 65
E3		Solenoid coil with the connector AMP- Junior-Timer 2 PIN Type of protection to EN 60 529 - IP 67
E4		Solenoid coil with the integrated quenching diode (bipolar transil diode) and the connector AMP- Junior-Timer 2 PIN Type of protection to EN 60 529 - IP 67
E12		Solenoid coil with the connector Deutsch DT04-2P Type of protection to EN 60 529 - IP 67 / IP 69K
E13		Solenoid coil with the integrated quenching diode (bipolar transil diode) and the connector Deutsch DT04-2P Type of protection to EN 60 529 - IP 67 / IP 69K

Manual Override

Dimensions in millimeters (inches)

STANDARD	RUBBER BOOT
<p>Dimensions</p> <p>65,5 (2.579)</p> <p>Standard model of the manual override.</p>	<p>Type M2 Dimensions</p> <p>78,5 (3.091)</p> <p>Manual override protected by rubber boot.</p>

Valve Dimensions

Dimensions in millimeters (inches)

1

Valve with two solenoids

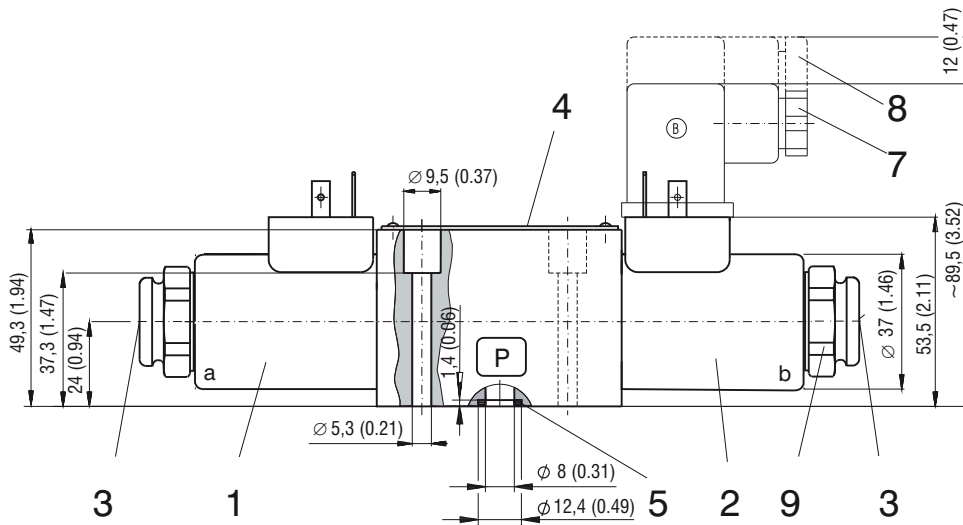
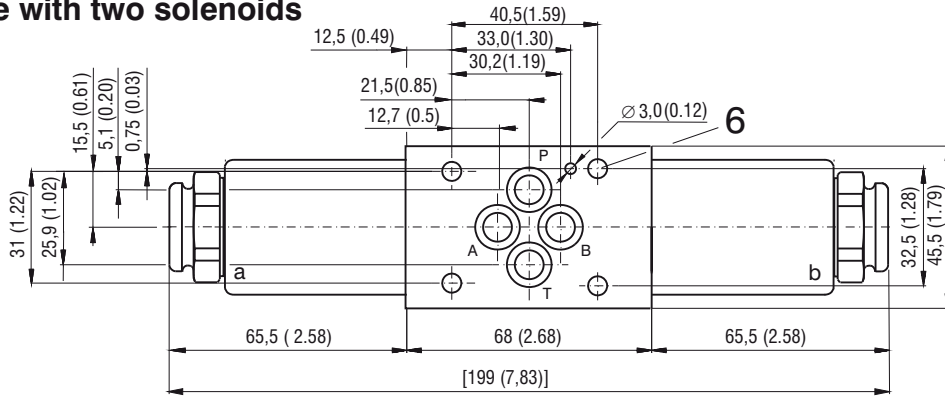

Valve with one solenoid "a"

Spool symbols R11, Z51, C51, H51, Y51

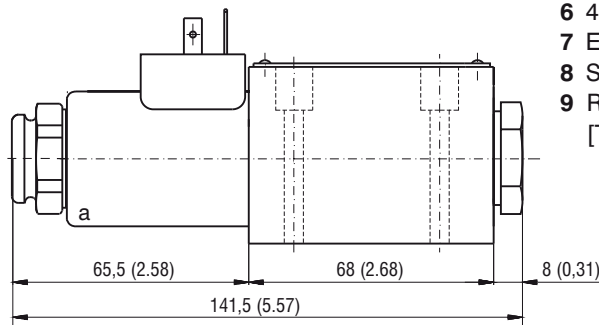

- 1 Solenoid a
- 2 Solenoid b
- 3 Manual override
- 4 Name plate
- 5 Square ring (4 pcs.)
9.25 x 1.68 supplied with valve
- 6 4 mounting holes
- 7 Electrical connector, EN 1745301-803-A
- 8 Space required to remove connector
- 9 Retaining nut of the solenoid
[Tightening torque 3+1 Nm (2.2+0.7 lbf.ft)]

Valve with one solenoid "b"

Spool symbols Z11, X11, C11, H11, Y11

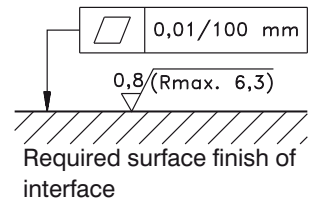
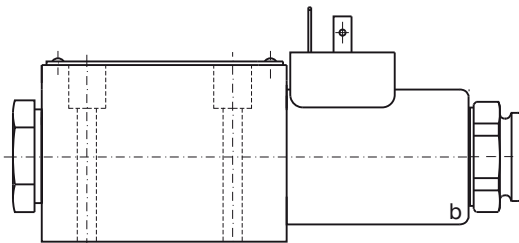

Spare Parts

- 1 Solenoid coil
- 2 Nut with seal
- 3 Kit M2
- 4 Seal kit
- 5 Mounting bolts
- 6 Electrical connector

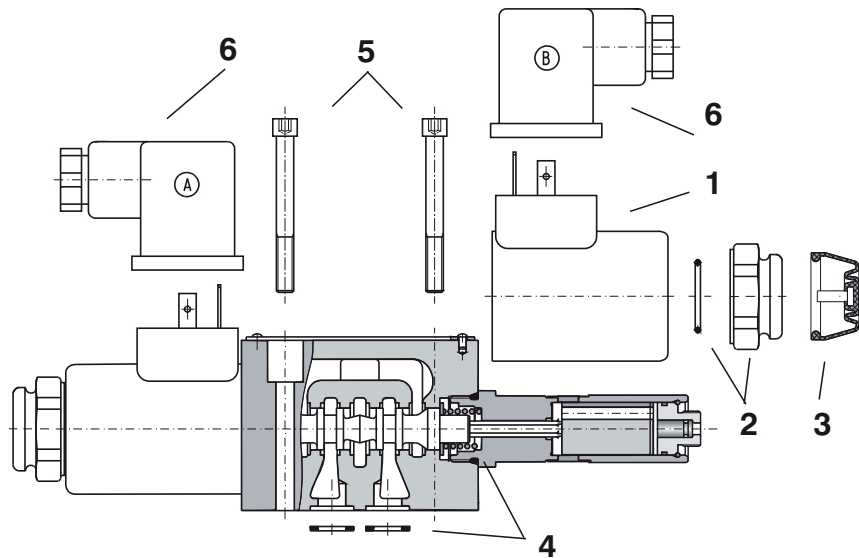

1. Solenoid coil

For selection of solenoid coil and terminal box type use catalogue HA 8007.

Solenoid type	Coil type					
	E1	E2	E3	E4	E12	E13
01200	27316600	27631400	27330200	27631600	27351400	27632000
02400	27316700	27632400	27449700	27633400	27330500	27633500

2. Solenoid retaining nut with seal

Type of the nut	Seal ring	Ordering number
Standard nut	18 x 1,5	15874500

3. Kit M2

Rubber boot with pin	24142800
----------------------	----------

4. Seal kit

Type	Dimensions, number	Ordering number
Standard - NBR70	9,25 x 1,68 (4 pcs.)	15845200

5. Mounting bolts

Dimensions, number	Tightening torque	Ordering number
M5 x 45 DIN 912-10.9 (4 pcs.)	8,9 Nm	15845100

6. Electrical connector, EN 175301-803

Type designation	Type	Model	Max. input voltage	Ordering number	
K1	Connector B (black)	without rectifier - M16x1.5 (bushing bore \varnothing 6-8 mm)	230 V AC/DC	16202100	
	Connector A (gray)			16202200	
K2	Connector B (black)	without rectifier with LED and quenching diode - M16x1.5 (bushing bore \varnothing 6-8)	12...24 V DC	16202700	
	Connector A (gray)			16202800	

Caution!

- For applications outside the given parameters, please consult us.
- For directional control valves with two solenoids, one solenoid must be without power before the other solenoid can be powered charged. Other spool types are available on request.
- The packing foil is recyclable.
- The protective plate can be returned to the manufacturer.
- The tightening torque is 8,9 Nm.
- The technical information regarding the product presented in this catalogue is for descriptive purposes only. It should not be construed in any case as a guaranteed representation of the product properties in the sense of the law.

ARGO-HYTOS a. s. CZ - 543 15 Vrchlabí
 Tel.: +420-499-403 111
 E-mail: info.cz@argo-hytos.com
 www.argo-hytos.com

- 4/3-, 4/2- way directional control valves
- Solenoids can be turned around their axis to any position
- Four-land spool - reduced functional dependence on fluid viscosity
- Push button manual override
- Installation dimensions to DIN 24 340 / ISO 4401 / CETOP RP121-H
- Subplates see data sheet HA 0002
- CSA Upon request

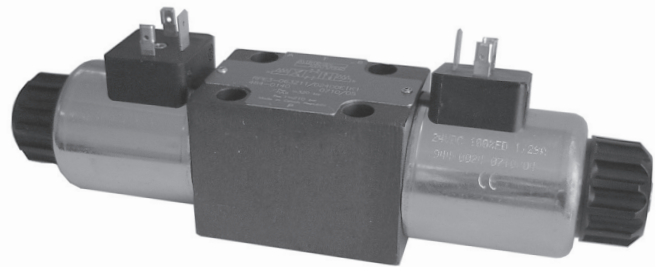
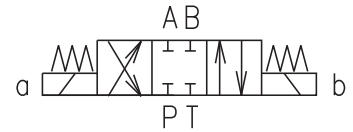

Functional Description

The RPE3 directional control valves consist of housing (1), a control spool (5) with two centering springs (4) and cylindrical operating solenoids (2, 3).

The three-position directional control valves are fitted with two solenoids and two springs. Two-position directional control valves have either one solenoid and one return spring or two solenoids and a detent assembly.

The operating solenoids are DC solenoids. For AC supply the solenoids are provided with a rectifiers which

are integrated in the DIN connector socket as part of the solenoid. The connectors (6, 7) can be turned by 90°. By loosening the nut (8), the solenoids can be turned or replaced without interfering with any seals of the valve. In the case of solenoid malfunction or power failure, the spool of the valve can be shifted by manual override (9), provided the pressure in T-port does not exceed 25 bar. The valve housing (1) is phosphate coated and the solenoids (2, 3) are zinc coated.

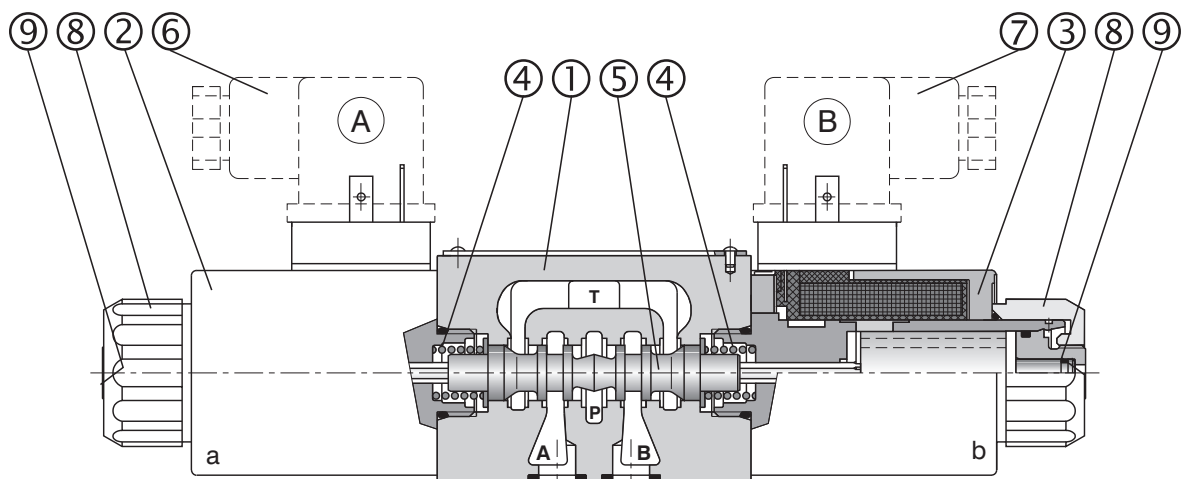

Ordering Code

RPE3-06 /

Directional Control Valves Solenoid Operated

Valve size

Number of valve positions

two positions **2**
three positions **3**

Spool symbols

see the table spool symbols

Rated supply voltage of solenoids

(at the coil terminals)

12 V DC / 2.72 A **01200**
24 V DC / 1.29 A **02400**
205 V DC / 0.15 A **20500**
230 V AC / 0.17 A / 50 (60) Hz **23050**

The AC coils correspond with E5 type

CSA Upon request 

Type of solenoid coil

with terminal for the connector, EN 1745301-803 **E1**
with integrated quenching diode and terminal for the connector, EN 1745301-803 **E2**
with AMP-Junior-Timer-connector **E3A**
with integrated quenching diode and terminal for AMP-Junior-Timer connector **E4A**
with integrated rectifier and terminal for the connector, EN 1745301-803 **E5**

Other coils on demand see catalog HA8007

Sensing of the end position

no designation without sensor
S1 normally-open sensor to 50 bar (725PSI)
S2 normally-open sensor to 210bar (3045 PSI)
S4 normally-closed sensor to 50bar (725 PSI)

Seals

no designation NBR
V FPM (Viton)

Orifice in P port

no designation without orifice
D1 Ø1.0 mm (0.039 inch)
D2 Ø1.5 mm (0.059 inch)
D3 Ø2.0 mm (0.079 inch)
D4 Ø2.2 mm (0.087 inch)
D5 Ø2.5 mm (0.098 inch)

Soft Shift -

Spool speed control orifice

no designation without damping
T1 orifice Ø 0.7 mm (0.03 inch) in solenoid

Manual override

no designation Standard
N1 covered with retaining nut
N2 covered with rubber boot
N3 with detent assembly

Note: Connector of the position sensor **is not supplied**
(see ordering number on page 10)

FOR PREFERRED TYPES SEE BOLD TYPING IN ORDERING CODE, FUNCTIONAL SYMBOLS AND TABLE OF PREFERRED TYPES ON PAGE 10

Technical Data

Valve size	mm (US)	D 06 (03)
Maximum flow	L/min (GPM)	see p-Q characteristics
Max. operating pressure at porte P, A, B	bar (PSI)	standard 350 (5076), according to CSA 320 bar (4641PSI)
Max. operating pressure at port T	bar (PSI)	50 (725) for version S1, S4 and 210 (3000) for version S2
Pressure drop	bar (PSI)	see Δp-Q characteristics
Hydraulic fluid		Hydraulic oils of power classes (HL, HLP) to DIN 51524
Fluid temperature range for NBR seals	°C (°F)	-30 ... +80 (-22 ... +176)
Fluid temperature range for FPM seals	°C (°F)	-20 ... +80 (-4 ... +176)
Ambient temperature max.	°C (°F)	+50 (+122)
Viscosity range	mm ² /s (SUS)	20 ... 400 (98 ... 1840)
Maximum degree of fluid contamination		Class 21/18/15 to ISO 4406
Max. allowable voltage variation	%	DC: ±10 AC: ±10
Max. switching frequency	h ⁻¹	15 000
Switching time, on: at v=32 mm ² .s ⁻¹ (156 SUS)	ms	DC: 30 ... 50 AC: 30 ... 40
Switching time, off: at v=32 mm ² .s ⁻¹ (156 SUS)	ms	DC: 10 ... 50 AC: 30 ... 70
Duty cycle	%	100
Service life	cycles	10 ⁷
Enclosure type to EN 60 529		IP 65
Weight - valve with 1 solenoid	kg (lbs)	1.6 (3.52)
- valve with 2 solenoids		2.2 (4.84)
Mounting position		unrestricted

Spool Symbols

Type	Symbol	Crossover	Type	Symbol	Crossover
Z11			Z51		
C11			Z71		
H11			Z81		
P11			Z91		
Y11			R31		
L21			H51		
B11			F51		
Y41			Z11		
Z21			X11		
C41			C11		
F11			H11		
R11			K11		
R21			N11		
A51			F11		
P51			X25		
Y51			J15		
C51			J75		

p-Q Characteristics

Measured at $v = 32 \text{ mm}^2/\text{s}$ (156 SUS)

Operating limits for maximum hydraulic power transferred by the directional valve.
For respective spool type - see spool symbols.

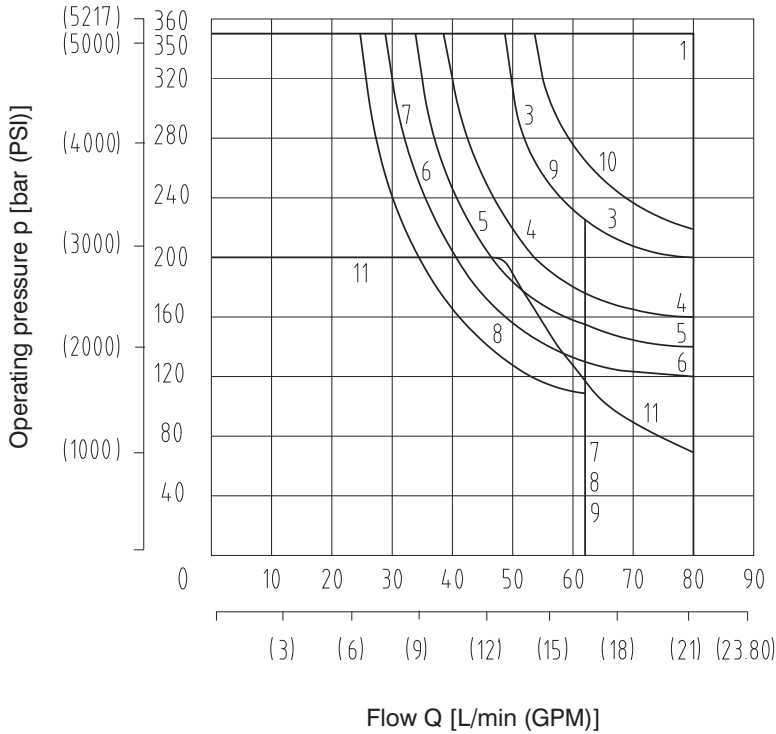

Z11	1
C11	7
H11	4
P11	1
Y11	3
L21	6
B11	9
Y41	7
Z21	1
C41	6
F11	6
R11	4
R21	5
A51	6
P51	1
Y51	3
C51	7
Z51	1
Z71	8
Z81	8
Z91	8
R31	6
H51	8
F51	8
X11	4
K11	8
N11	8
X25	11
J15	1
J75	10

Δp-Q Characteristics

Measured at $v = 32 \text{ mm}^2/\text{s}$ (156 SUS)

Pressure drop Δp related to flow rate.

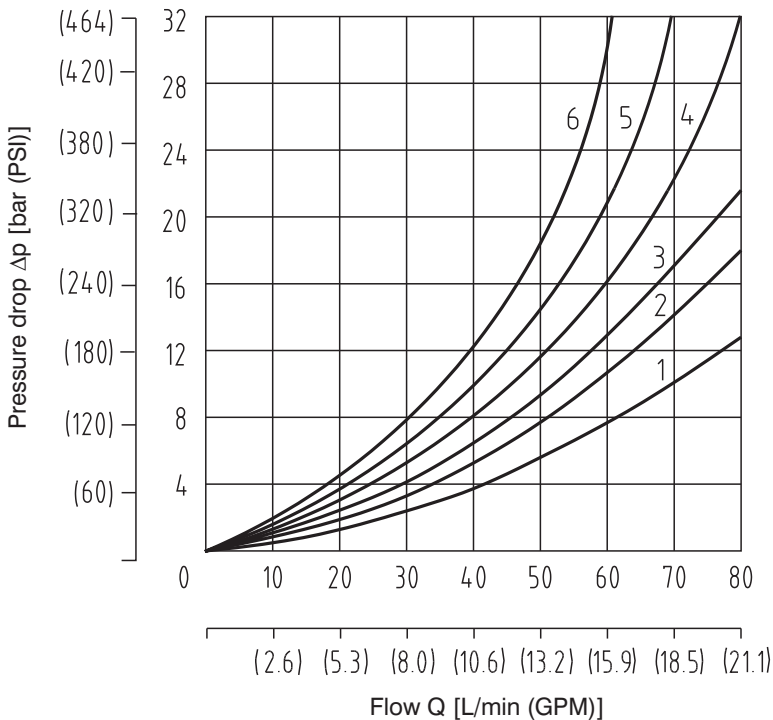

	P-A	P-B	A-T	B-T	P-T
Z11	2	2	3	3	
C11	5	5	5	6	3
H11	2	2	2	3	3
P11	1	1	3	3	
Y11	2	2	2	2	
L21	2	2	3	3	
B11	2	2	3	3	
Y41	3	3	3	3	
Z21		2	3		
C41	4	4			5
F11	1	2		3	3
R11	2	2	3	3	
R21	2	2	3	3	
A51	2	2			
P51		1	3		
Y51		2	2		
C51	2			3	4
Z51		2	3		
Z71	3	3			
Z81			3	3	
Z91	3			3	3
R31	2			3	
H51		2	3		
F51		2	3		
X11	2	2	3	3	
K11		2	3		
N11	2	2	3	3	
X25	3	3	3		
J15	2	2	3	3	
J75	2	2			

Valve Dimensions

Dimensions in millimeters (inches)

1

Valve with two solenoids

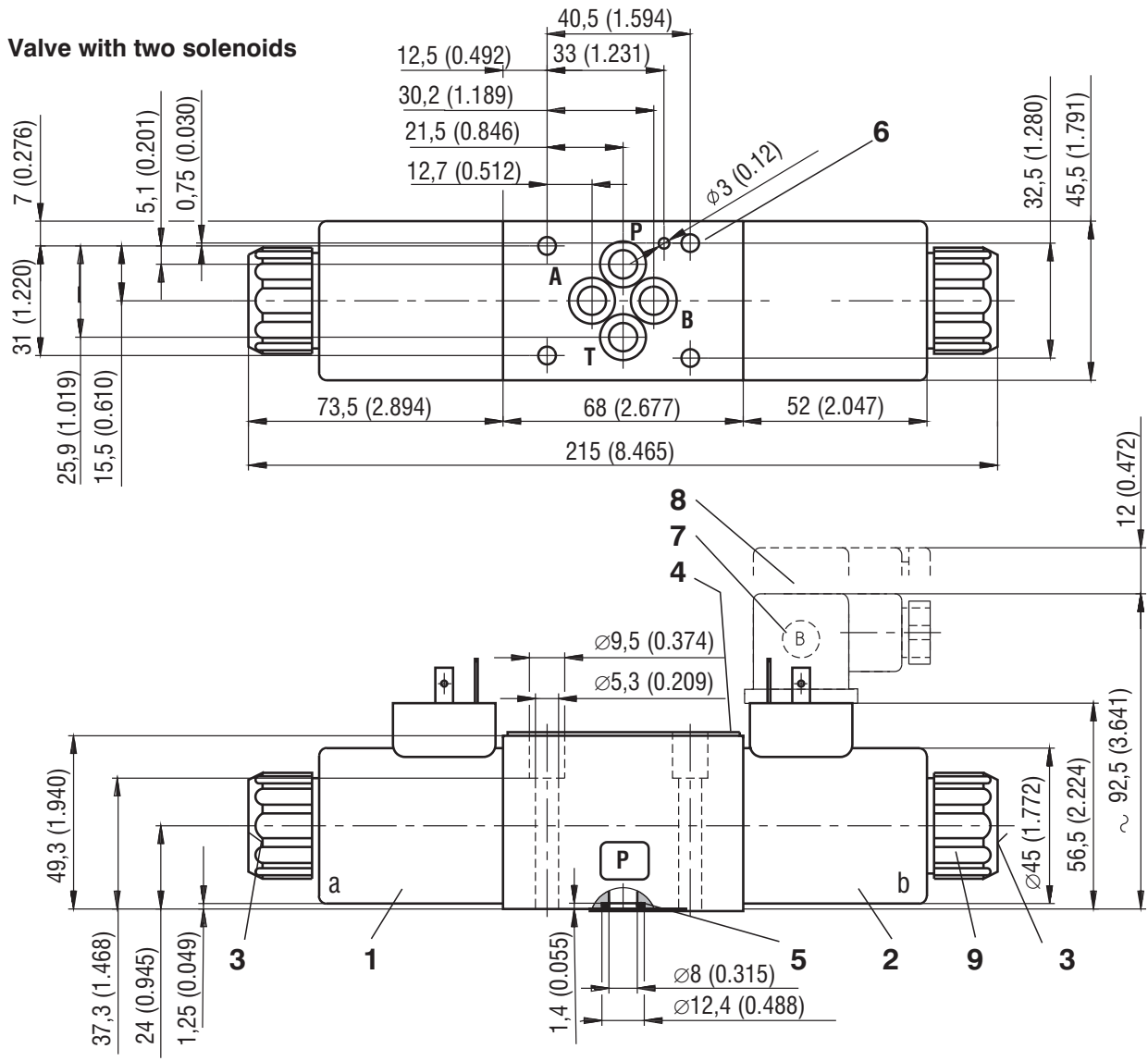

Valve with one solenoid "a"

Spool symbols R11, R21, A51, P51, Y51, Z51, C51, Z71, Z81, Z91, R31, H51, F51, X25

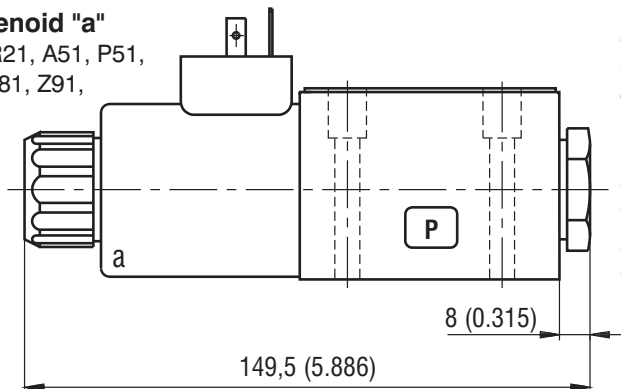

- 1 Solenoid a
- 2 Solenoid b
- 3 Manual override
- 4 Name plate
- 5 Square ring (4 pcs.)
9.25 x 1.68 supplied with valve
- 6 4 mounting holes
- 7 Electrical connecto, EN 1745301-803
- 8 Space required to remove connector
- 9 Solenoid fixing nut
[Nut torque 2.95 ft-lbs (4 Nm)]

Valve with one solenoid "b"

Spool symbols X11, Z11, C11, H11, K11, N11, F11

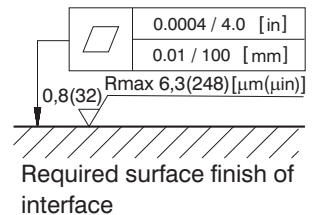
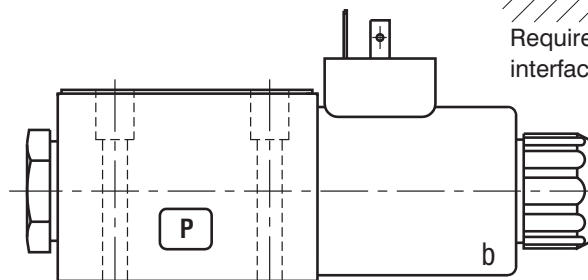

Required surface finish of interface

Type of the Solenoid Coil

Designation	Dimensional sketch	Description
E1		Solenoid coil with terminal for the electrical connector, EN 1745301-803.
E2		Solenoid coil with integrated quenching diode (bipolar transil diode) and terminal for the electrical connector, EN 1745301-803.
E3A		Solenoid coil with terminal for AMP-Junior-Timer electrical connector.
E4A		Solenoid coil with integrated quenching diode (bipolar transil diode) and terminal for AMP-Junior-Timer electrical connector.
E5		Solenoid coil with integrated rectifier and terminal for the electrical connector, EN 1745301-803.

Manual Override

STANDARD	CLOSED NUT
<p>no designation Dimensions</p> <p>Standard model of the manual override. Standard retaining nut of the solenoid.</p>	<p>Type N1 Dimensions</p> <p>Manual override with retaining nut. Can be used after removing nut.</p>
RUBBER BOOT	DETENT ASSEMBLY
<p>Type N2 Dimensions</p> <p>Manual override protected by rubber boot.</p>	<p>Type N3 Dimensions</p> <p>Manual override holds the spool in the shifted position.</p>

Spool Speed Control Orifice

Type	Dimension	Description
T1		<p>Important: This directional valve provides control spool soft shifting by means of orifice situated in the solenoid armature. To ensure the proper function of the valve, perfect air bleeding of the solenoid is required (by us of bleeding plug (1). The plugs are accessible after removing the rubber boot (2) from the solenoid retaining nut (3).</p>

Switching times

Switching time, on and off	ms	300 ... 800
----------------------------	----	-------------

The switching times shown are valid for viscosity $\nu = 32 \text{ mm}^2/\text{s}$ (156 SUS) and nominal voltage. They are dependent upon working pressure and flow rate of the directional control valve

Orifice in P-Port

Type	ØD mm (inch)	Dimensions	Description
D1	1,0 (0.039)		<p>P-port orifices limit the flow into the directional control valve.</p> <p>Attention: When the orifice in P port is additionally mounted the standard used square ring NBR is replaced with O-ring from Viton.</p>
D2	1,5 (0.059)		
D3	2,0 (0.079)		
D4	2,0 (0.087)		
D5	2,0 (0.098)		

Spool Ship Position Sensor

S1, S2 - Circuit diagram of the normally-open sensor

S4 - Circuit diagram of the normally-closed sensor

The proximity sensor transforms the spool position into an electrical step signal. It can be used with directional control valves with one or two solenoids.

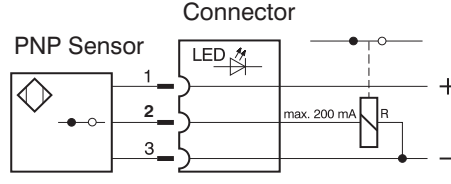
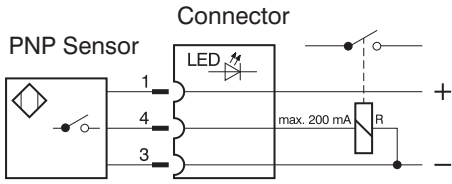

Technical Data of the Sensor

Rated power supply voltage	V	S1, S4	24 DC	S2
Power supply voltage range	V		10 ... 30 DC	
Rated current	mA		200	
Enclosure type of sensor to EN 60529			IP 67	
Max. operating pressure	bar (PSI)		50 (725)	210 (3046)
Switching frequency	Hz		1000	
Ambient temperature range	°C (°F)		-25 ... +80 (-13 ... +176)	

Technical Data of the Connector

Power supply voltage range	V	10 ... 30 DC
Ambient temperature range	°C (°F)	-25 ... +80 (-13 ... +176)
Indication		yellow LED

Two-Position Directional Control Valve

Dimensions in millimeters (inches)

Signal of solenoid a (b)	Signal of sensor Sa (Sb)		LED	
	S1, S2 - normally-open	S4 - normally-closed	S1, S2	S4
0	1	0	ON	OFF
1	0	1	OFF	ON

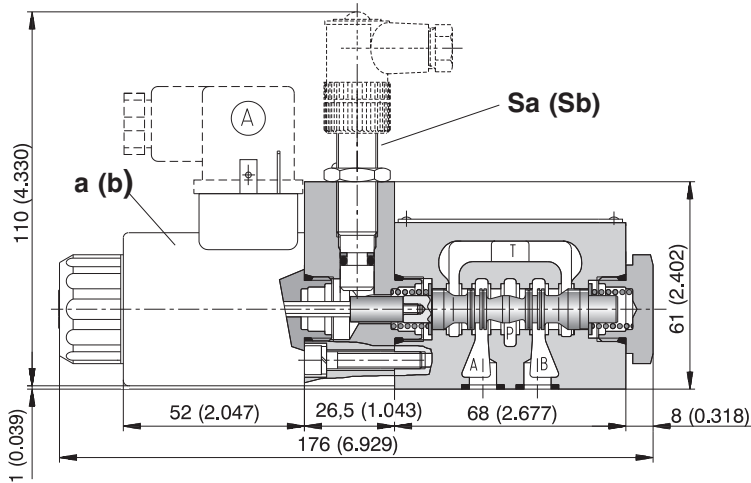

Three-Position Directional Control Valve

Dimensions in millimeters (inches)

Signal of solenoid		Signal of sensor Sa (Sb)				LED			
		S1, S2 - normally-open		S4 - normally-closed		S1, S2		S4	
a	b	Sa	Sb	Sa	Sb	Sa - LED	Sb - LED	Sa - LED	Sb - LED
0	0	1	1	0	0	ON	ON	OFF	OFF
1	0	0	1	1	0	OFF	ON	ON	OFF

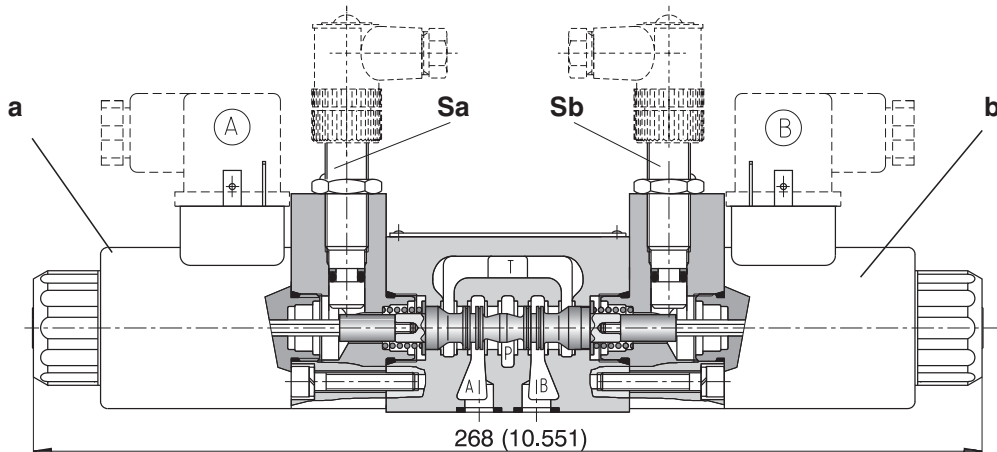

Spare Parts

- 1 Electrical connector
- 2 Solenoid coil
- 3 Nut with seal
- 4 Orifice in P port with seal ring
- 5 Sensor
- 6 Connector of position sensor with LED
- 7 Seal kit
- 8 Mounting bolts

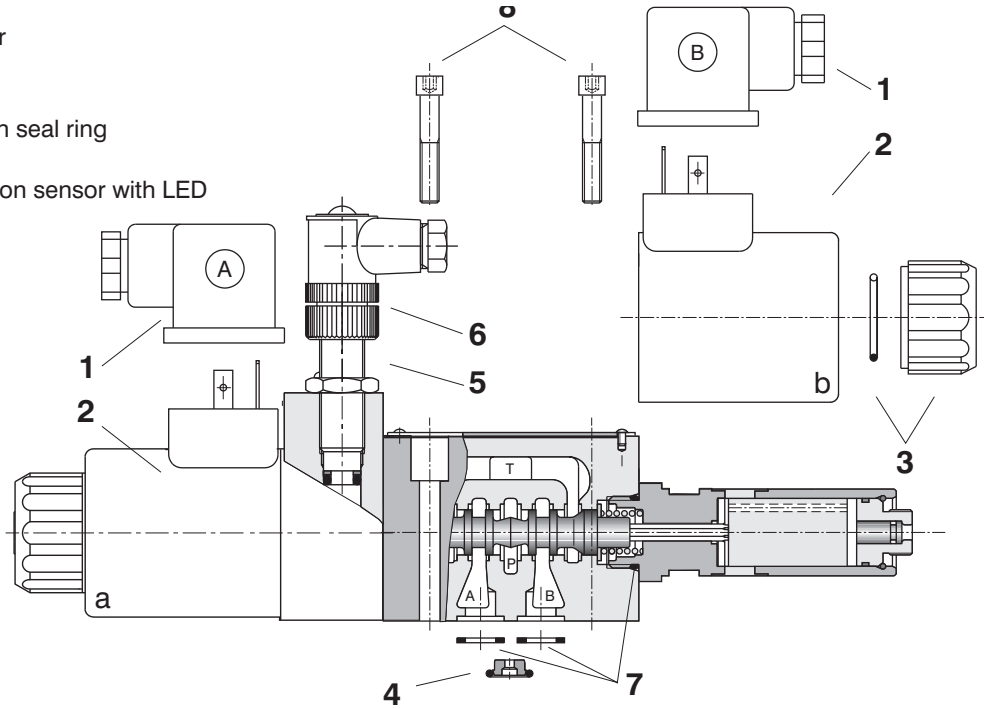

Solenoid coil					
Solenoid type	Coil type				
	E1	E2	E3A	E4A	E5
Order number					
01200	16211400	24156100	24159600	24159700	
01200*	24154300	-	-	-	
02400	-	24157400	24159800	24159900	
02400*	24154400				
20500	-				
23500				18849000	
23500*				24154600	

*CSA Upon request

Solenoid retaining nut with seal		
Type of the nut	Seal ring	Order number
Standard nut	22 x 2	15844600
Closed nut		15844700
Nut with rubber boot		15844800
Nut with detent assembly		15844900

Connector of position sensor			
Type designation	Model	Max. input voltage	Ordering number
K02	connector of position sensor with LED	10...30 V DC	17364800
S1	normally-open sensor	10...30 V DC	16688500
S2	normally-open sensor	10...30 V DC	18838900
S4	normally-closed sensor	10...30 V DC	20725300

Orifice in P-port			
Type	ØD mm (inch)	Seal ring	Order number
D1	1,0 (0.039)	9.25 x 1.75	15845600
D2	1,5 (0.059)		15845700
D3	2,0 (0.079)		15845800
D4	2,2 (0.087)		15846000
D5	2,5 (0.098)		15845900

Bolt kit		
Dimensions, quantity	Bolt torque	Order number
M5 x 45 DIN 912-10.9 (4 pcs.)	8.9 Nm (6.6 ft-lbs)	15845100

Seal kit			
Type	Dimensions, quantity		Order number
Standard - NBR70	9,25 x 1,68 x 1,68 (4 pcs.)	17 x 1.8 (2 pcs.)	15845200
Viton	9,25 x 1,78 (4 pcs.)	17,17 x 1,78 (2 pcs.)	15845400

Electrical connector, EN 1745301-803		
Type	Connector A grey	Connector B black
	Ordering number	
K1	16202200	16202100
K5	16202600	16202500
K2	16202800	16202700
K3	16202400	16202300
K4	16203000	16202900

Electrical Connector, EN 175301-803				
K1	Connector B (black)	without rectifier - M16x1.5 (bushing bore Ø 6-8 mm)	230 V AC/DC	
	Connector A (grey)			
K5	Connector B (black)	without rectifier - M16x1.5 (bushing bore Ø 4-6 mm)	230 V AC/DC	
	Connector A (grey)			
K2	Connector B (black)	without rectifier with LED and quenching diode - M16x1.5 (bushing bore Ø 6-8 mm)	12 ... 24 V DC	
	Connector A (grey)			
K3	Connector B (black)	with rectifier - M16x1.5 (bushing bore Ø 6-8 mm)	230 V AC	
	Connector A (grey)			
K4	Connector B (black)	with rectifier with LED and quenching diode - M16x1.5 (bushing bore Ø 6-8 mm)	230 V AC	

Recommended solenoid coils used with electrical connector with rectifiers - **type designation K3, K4**

Rated supply source voltage (permissible rated voltage variation $\pm 10\%$)	Type designation of the solenoid voltage
230 V AC / 0.17 A / 50 (60) Hz	20500

Preferred Types of Valves

Type	Ordering Number	Type	Ordering Number
RPE3-062Z11/01200E1	15720300	RPE3-063Y11/02400E1	15728400
RPE3-063Z11/01200E1	15711300	RPE3-062R11/02400E1	15731100
RPE3-062Z51/01200E1	15719300	RPE3-062R21/02400E1	15734500
RPE3-063C11/01200E1	15712600	RPE3-062A51/02400E1	15732800
RPE3-062C51/01200E1	15719600	RPE3-062Y51/02400E1	15737400
RPE3-063H11/01200E1	15713500	RPE3-062J15/02400E1	15733500
RPE3-063Y11/01200E1	15714300	RPE3-062Z11/23050E5	15768800
RPE3-062R11/01200E1	15716000	RPE3-063Z11/23050E5	15747100
RPE3-062R21/01200E1	15717100	RPE3-062Z51/23050E5	21262800
RPE3-062A51/01200E1	15716700	RPE3-063C11/23050E5	15748900

Caution!

- When the distributor contains two electromagnets any of the two electromagnets can be switched on only after the other one switches off. The electromagnets switching time on distributors with locking arrangement must not be shorter than 60 ms. With directional valves with cushioned spool shifting, the switching time must correspond with the shifting time.
- Distributors with other interconnections than those shown in the catalogue can be supplied on request.
- The packaging foil can be recycled
- The transport base plate can be returned to the manufacturer.
- Mounting screws M5 x 45 DIN 912-10.9 or bolts must be ordered separately.
The screws tightening torque is 8.9 Nm (6.6 ft-lbs).
- The mentioned data only serve to describe the product and in no case are to be understood in terms of law as guaranteed characteristics.

ARGO-HYTOS s.r.o. CZ - 543 15 Vrchlaví
Tel.: +420-499-403 111
E-mail: info.cz@argo-hytos.com
www.argo-hytos.com

- 4/3-, 4/2- way directional control valves
- Enclosure type to IP65
- Push button manual override
- Installation dimensions to DIN 24 340 / ISO 4401 / CETOP RP121-H
- Subplates see data sheet HA 0002

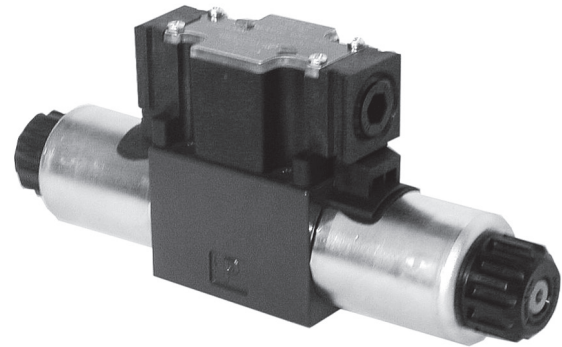
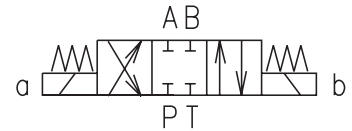

Functional Description

The RPEA3 directional control valves consist of housing (1), a control spool (5) with two centering springs (4), cylindrical operating solenoids (2, 3), electric wirebox (9) and connector (6).

The three-position directional control valves are fitted with two solenoids and two springs. Two-position directional control valves have either one solenoid and one return spring or two solenoids and a detent assembly.

The solenoids are supplied with DC voltage through the Ports on the wirebox optional on both sides or through Connector Item (5 - Pin) M12, see wiring diagram (page

6). The wires are connected to a terminal plate inside the wirebox. Optional lights are installed on this terminal plate for shift indication. The lights are visible as raised arrows on the valve label. The solenoids are retained by the Nut (7) and plug-in to the wirebox. Plug-in design allows easy removal without wire change.

In the case of solenoid malfunction or power failure, the spool of the valve can be shifted by manual override (8), provided the pressure in T- port does not exceed 25 bar (362,5 PSI).

The valve housing (1) is phosphate coated and the solenoids (2, 3) are zinc coated.

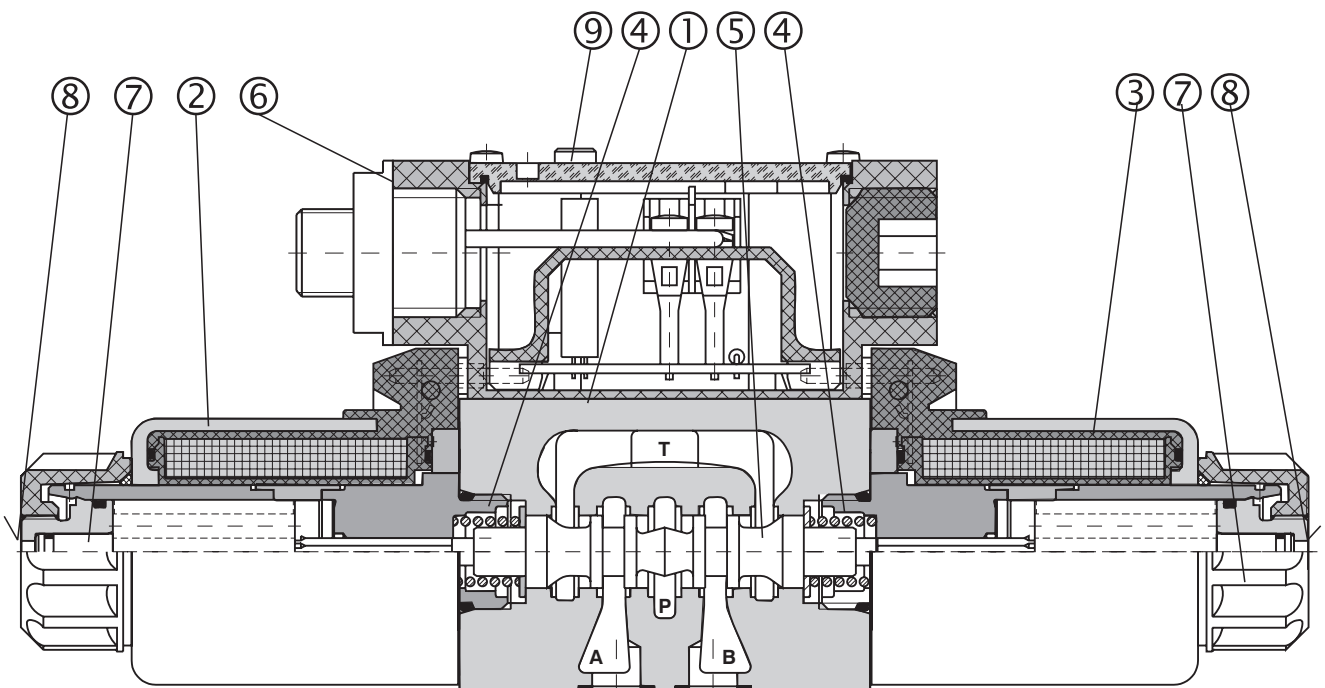

Ordering Code

RPEA3-06 /

Solenoid - Operated Directional Control Valves with 8W Coil

Nominal Size

Number of Valve Positions

two positions
three positions

2
3

Spool Symbols

see the table spool symbols

Rated Supply Voltage of Solenoids

24 V DC / 0.33 A

02400

Type of Solenoid Coil for Wiring Box (Plug-In-Coil)

DC solenoid 8W

EW1

Type of Wirebox

Wirebox for DC and AC

K

Solenoid identification
no designation standard ISO
A US Standard ANSI-B93.9

Seals
no designation
V NBR
FPM (Viton)

Orifice in P Port
no designation without orifice
D1 Ø1.0 mm (0.039 in)
D2 Ø1.5 mm (0.059 in)
D3 Ø2.0 mm (0.079 in)
D4 Ø2.2 mm (0.087 in)
D5 Ø2.5 mm (0.098 in)

Manual Override
no designation standard
N1 covered with retaining nut
N2 covered with rubber boot

Wirebox Configurations

- 63** Wiring box with 5 PIN connector M12 mounted on A-side (B-side plugged)
- 64** Wiring box with 5 PIN connector M12 mounted on B-side (A-side plugged)
- 65** Wiring box with 5 PIN connector M12 mounted on A-side with LED diode (B-side plugged)
- 66** Wiring box with 5 PIN connector M12 mounted on B-side with LED diode (A-side plugged)

Technical Data

Valve size	mm (US)	06 (D 03)
Maximum flow	L/min (GPM)	see p-Q characteristics
Max. operating pressure at porte P, A, B	bar (PSI)	350 (5076)
Max. operating pressure at port T	bar (PSI)	210 (3000)
Pressure drop	bar (PSI)	see Δp-Q characteristics
Hydraulic fluid		Hydraulic oils of power classes (HL, HLP) to DIN 51524
Fluid temperature range for NBR seals	°C (°F)	-30 ... +80 (-22 ... +176)
Fluid temperature range for FPM seals	°C (°F)	-20 ... +80 (-4 ... +176)
Ambient temperature max.	°C (°F)	+50 (+122)
Viscosity range	mm ² /s (SUS)	20 ... 400 (98 ... 1840)
Maximum degree of fluid contamination		Class 21/18/15 to ISO 4406
Max. allowable voltage variation	%	DC: ±10
Max. switching frequency	h ⁻¹	15 000
Switching time, on: at v=32 mm ² /s (156 SUS)	ms	DC: 30 ... 50
Switching time, off: at v=32 mm ² /s (156 SUS)	ms	DC: 10 ... 50
Duty cycle	%	100
Service life	cycles	10 ⁷
Enclosure type to EN 60529		IP 65
Weight - valve with 1 solenoid - valve with 2 solenoids	kg (lbs)	1,3 (2.9) 1,9 (4.2)
Mounting position		unrestricted

Functional Symbols

Type	Symbol	Crossover	Type	Symbol	Crossover
Z11			C51		
C11			Z51		
P11			Z11		
Y11			X11		
R11			C11		
P51			Y11		
Y51			P11		

Note: Contrary to the European Norm, the US Standard ANSI-B93.9 states that the solenoid routing on energizing the oil flow to port **A** be marked with **a**, and the solenoid routing on energizing the oil flow to port **B** be marked with **b**. This rule is valid independently from the solenoid lay-out.

p-Q Characteristics

Measured at $v = 32 \text{ mm}^2/\text{s}$ (156 SUS)

Operating limits for maximum hydraulic power transferred by the directional valve.

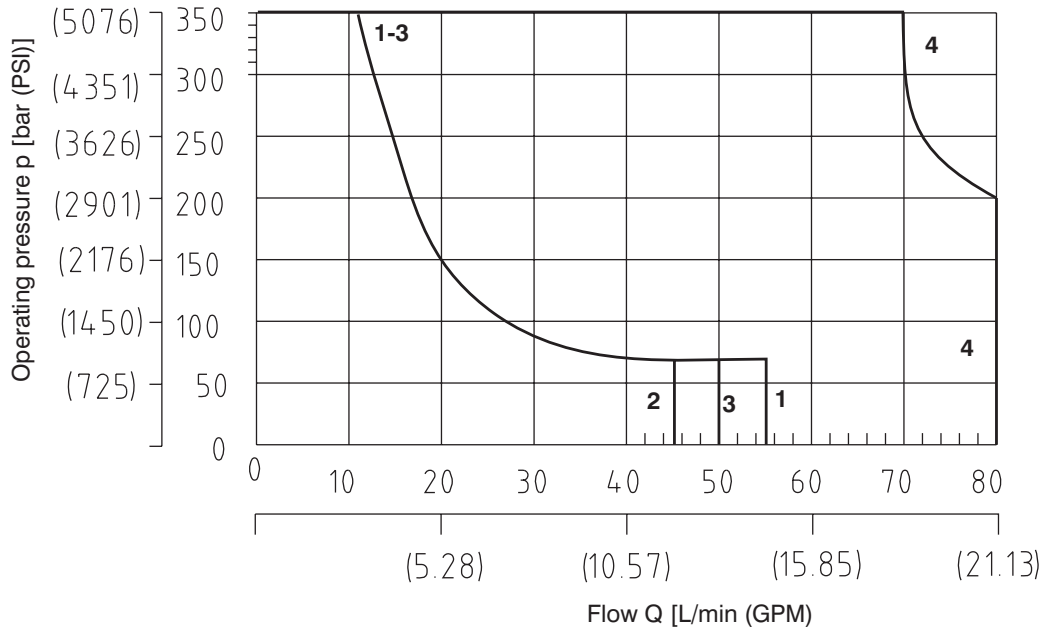

Z11	C11	P11	Y11	R11	P51	Z51	C51	X11	Y51
1	3	4	1	2	4	1	3	2	1

Δp -Q Characteristics

Measured at $v = 32 \text{ mm}^2/\text{s}$ (156 SUS)

Pressure drop Δp related to flow rate.

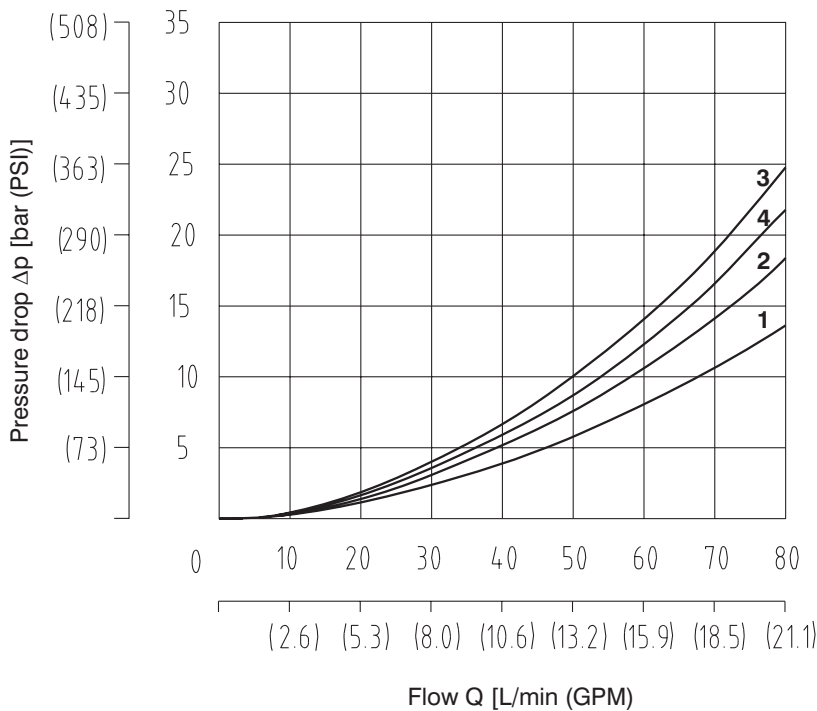

	P-A	P-B	A-T	B-T	P-T
Z11	2	2	2	2	
C11	2	2	2	2	3
P11	2	2	4	4	
Y11	2	2	1		
R11	2	2	4	2	
X11	2	2	4	2	
Z51		2	2		
C51	2			2	3
P51		1	1		
Y51		2	4		

Valve Dimensions

Dimensions in millimeters (inches)

1

Valve with two solenoids

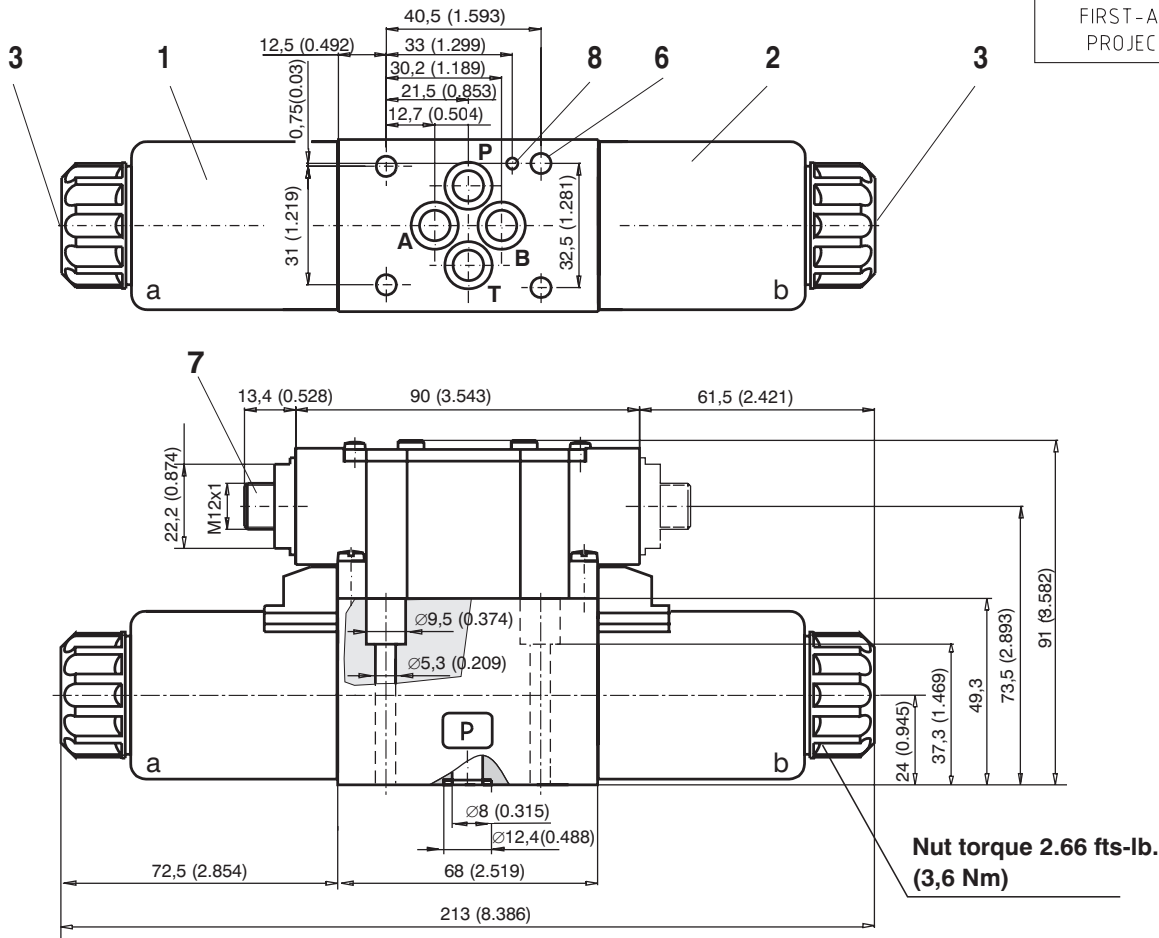
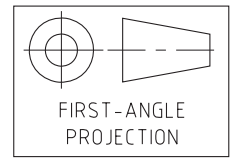

Valve with one solenoid a

Spool symbols R11, P51, Y51, Z51, C51

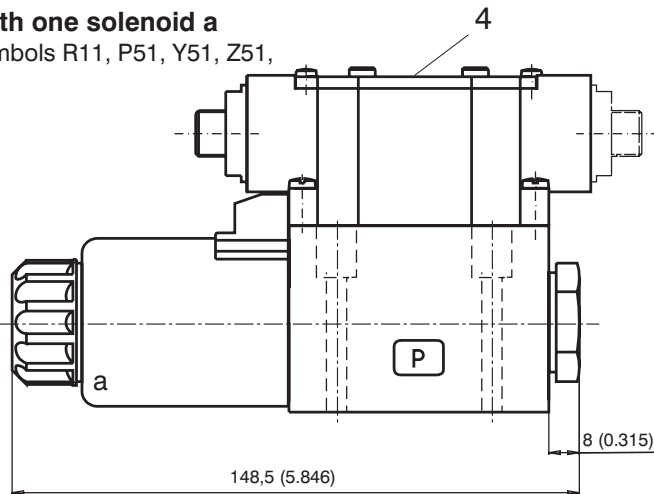

- 1 Solenoid a*
- 2 Solenoid b*
- 3 Manual override
- 4 Name plate
- 5 Square ring (4 pcs.)
0.36 x 0.66 (9.25 x 1.68 mm)
supplied with valve
- 6 4 mounting holes
- 7 Electrical connector
- 8 Pin hole

***Note:** On valves with solenoid identification according to US Standard ANSI-B93.9 can the solenoid designation vary from this arrangement, this is based on the function symbol.

Valve with one solenoid b

Spool symbols X11, Z11, C11, Y11, P11

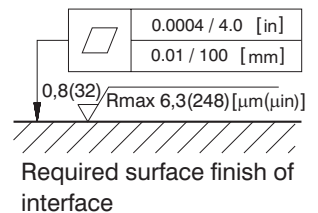
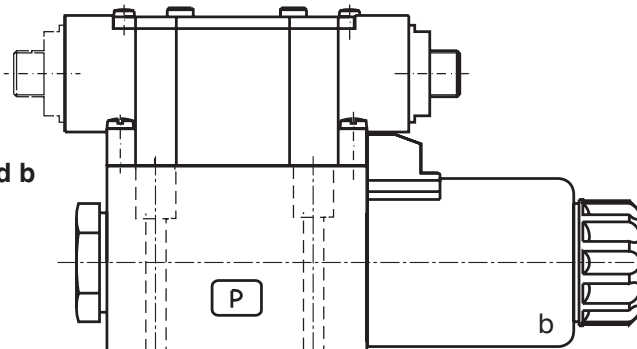

Manual Override

STANDARD

No designation
Dimensions

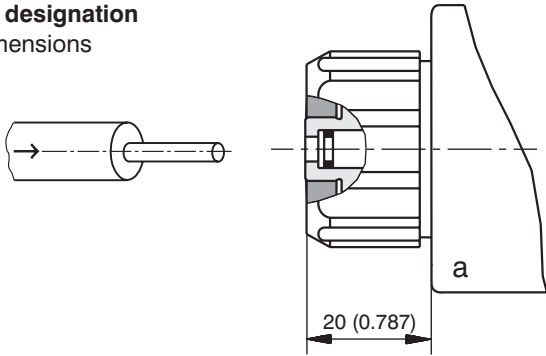

Standard model of the manual override.
Standard retaining nut of the solenoid.

CLOSED NUT

Type **N1** (For DC voltage solenoids only)
Dimensions

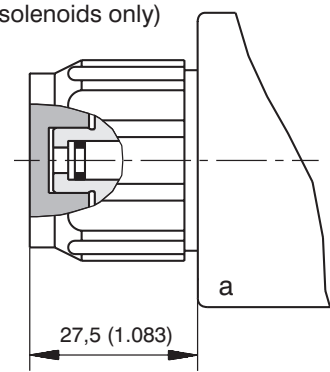

Manual override with retaining nut.
Can be used after removing nut.

RUBBER BOOT

Type **N2** (For DC voltage solenoids only)
Dimensions

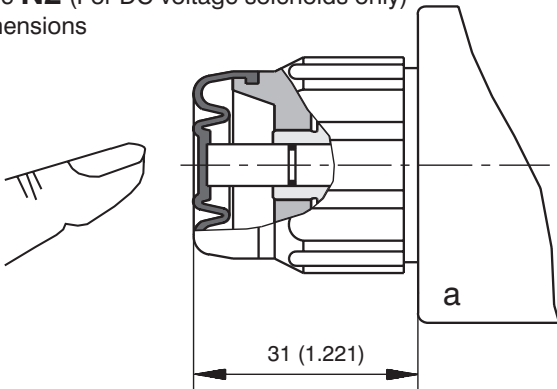

Manual override protected by rubber boot.

Orifice in P-Port

Type	ØD mm (inch)	Dimensions	Description
D1	1,0 (0.039)		P-Port orifices limit the flow into the directional control valve. Attention: When the orifice in P port is additionally mounted the standard used square ring NBR is replaced with O-ring from Viton.
D2	1,5 (0.059)		
D3	2,0 (0.079)		
D4	2,2 (0.087)		
D5	2,5 (0.098)		

Connector - M12

Pin - location

Valve with 2 Magnets

Magnet a

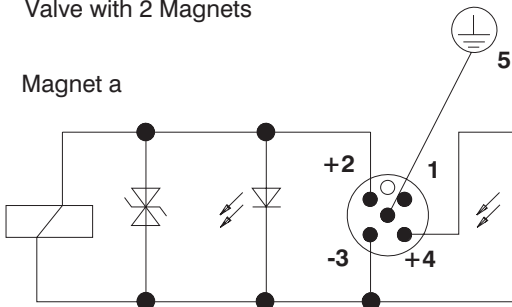

Pin - location

Valve with 1 Magnet

Magnet a or b

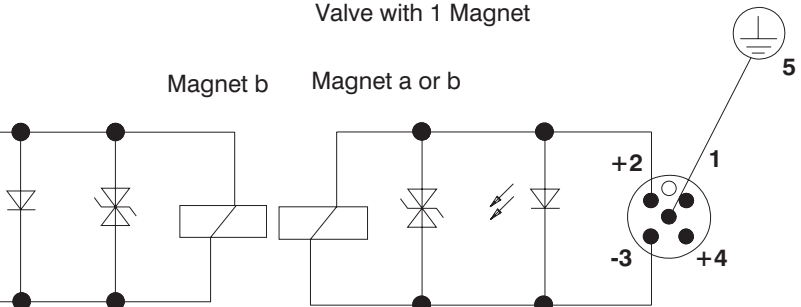

Note: On valves with solenoid identification according to US Standard ANSI-B93.9 wiring will be different from above: on valves with one (1) solenoid always Pin 2 for the *a*-Solenoid and Pin 4 for the *b*-Solenoid. This is independent from the actual physical location of the solenoid.

Spare parts

1

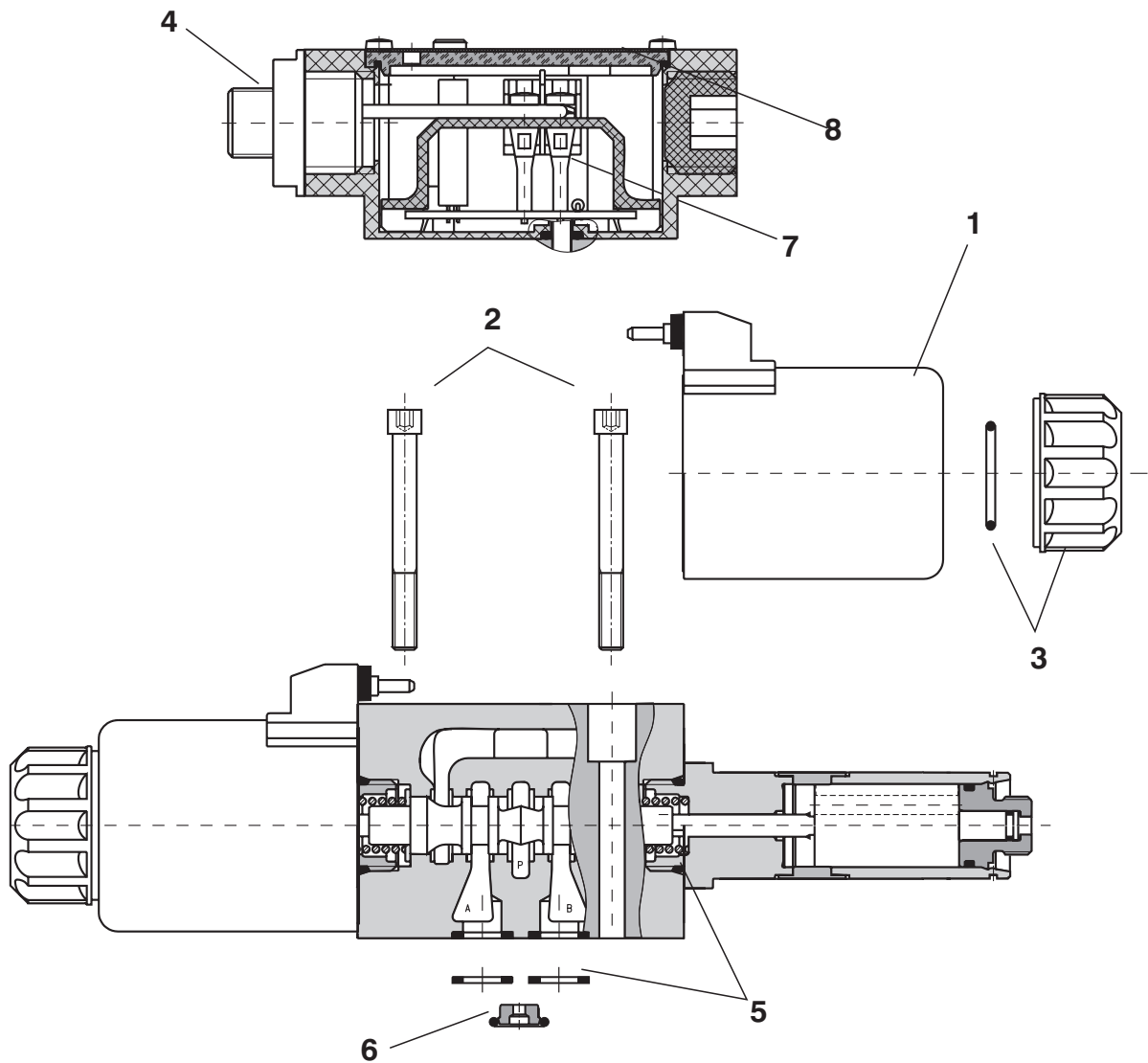

- 1 - Solenoid coil (DC solenoid)
- 2 - Mounting bolts
- 3 - Nut with seal (Nut torque 3 Nm (2.21lbf))
- 4 - Connector M12
- 5 - Seal kit
- 6 - Orifice in P port with seal ring
- 7 - Terminal plate
- 8 - Wiring box

Wiringbox				
Type			Ordering number	
Wiring box without terminal plate			16203600	
Terminal Plates				
Type			Ordering number	
Terminal plate 24V - preventive A+B			28572900	
Terminal plate 24V - preventive A			24007600	
Terminal plate 24V - preventive B			28572800	
Terminal plate 24V - LED diode and preventive A+B			24007700	
Terminal plate 24V - LED diode and preventive A			24007800	
Terminal plate 24V - LED diode and preventive B			28572800	
Solenoid Coil				
Voltage rating		Type	Ordering number	
24 V DC		EW1	24014000	
Solenoid Retaining Nut with Seal				
Type of the nut		Seal ring	Ordering number	
Standard nut		22 x 2	15844600	
Closed nut (DC only)			15844700	
Nut with rubber boot (DC only)			15844800	
Electrical Connector M12				
Type			Ordering number	
Male 5 PIN			24007900	
Orifice in P-Port				
Type	∅D mm (inch)	Seal ring	Ordering number	
D1	1.0 (0.039)	9.25 x 1.75	15845600	
D2	1.5 (0.059)		15845700	
D3	2.0 (0.079)		15845800	
D4	2.2 (0.087)		15846000	
D5	2.5 (0.098)		15845900	
Seal Kit				
Type	Dimensions, quantity		Ordering number	
Standard - NBR70	9.25 x 1.68 (4 pcs.)	17 x 1.8 (2 pcs.)	9.25 x 1.75 (1 pc)	21483800
Viton	9.25 x 1.78 (4 pcs.)	17.17 x 1.78 (2 pcs.)		15845400
Bolt Kit (for studs see HU 0030)				
Dimensions, quantity		Bolt torque	Ordering number	
M5 x 45 DIN 912-10.9 (4 pcs.)		8.9 Nm (6.6 lbf)	15845100	
Caution!				
<ul style="list-style-type: none"> When the distributor contains two electromagnets any of the two electromagnets can be switched on only after the other one switches off. Distributors with other interconnections than those shown in the catalogue can be supplied on request. The packaging foil can be recycled The transport base plate can be returned to the manufacturer. Mounting screws M5 x 45 DIN 912-10.9 or bolts must be ordered separately. The screws tightening torque is 8.9 Nm (6.6 ft-lbs). The mentioned data only serve to describe the product and in no case are to be understood in terms of law as guaranteed characteristics. 				
ARGO-HYTOS s.r.o. CZ - 543 15 Vrchlaví Tel.: +420-499-403 111 E-mail: info.cz@argo-hytos.com www.argo-hytos.com				

- 4/3-, 4/2- way directional control valves
- Four-land spool - reduced functional dependence on fluid viscosity
- Push button manual override
- Installation dimensions to DIN 24 340 / ISO 4401 / CETOP RP121-H
- Subplates see Data Sheet HA 0002
- CSA Upon request

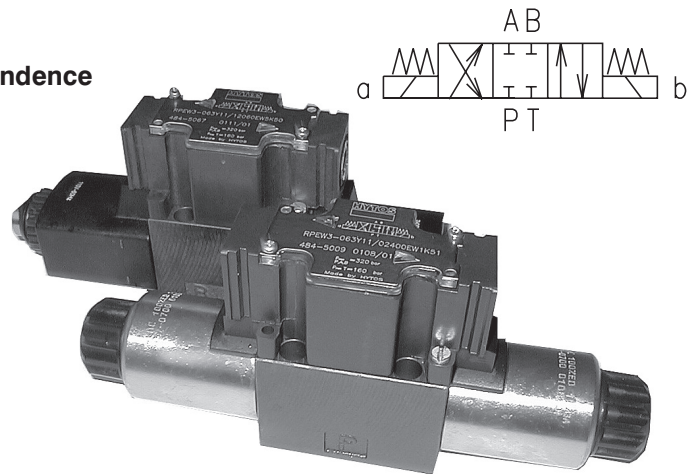

Functional Description

The RPEW4 directional control valves consist of housing (1), a control spool (5) with two centering springs (4) and cylindrical operating solenoids (2, 3), electric wirebox (9) and connector (6). 12 and 24 volt DC solenoids can be supplied with diodes (built in) the AC/DC rectifier is part of the terminal plate in the wirebox.

The three-position directional control valves are fitted with two solenoids and two springs. Two-position directional control valves have either one solenoid and one return spring or two solenoids and a detent assembly.

The solenoids are supplied with DC (2,3) voltage through the 1/2 NPT Ports on the wirebox (standard on both sides) or through Connector Item (3 - Pin single

solenoid, 5 - Pin - double solenoid) see wiring diagram (page 7). The wires are connected to a terminal plate inside the wirebox. Optional lights are installed on this terminal plate for shift indication. The lights are visible as raised arrows on the valve label. The solenoids are retained by the Nut (7) and plug-in to the wirebox. Plug-in design allows easy removal without wire change.

In the case of solenoid malfunction or power failure, the spool of the valve can be shifted by manual override (8), provided the pressure in T- port does not exceed 25 bar (362,5 PSI).

The valve housing (1) is phosphate coated and the solenoids (2, 3) are zinc coated.

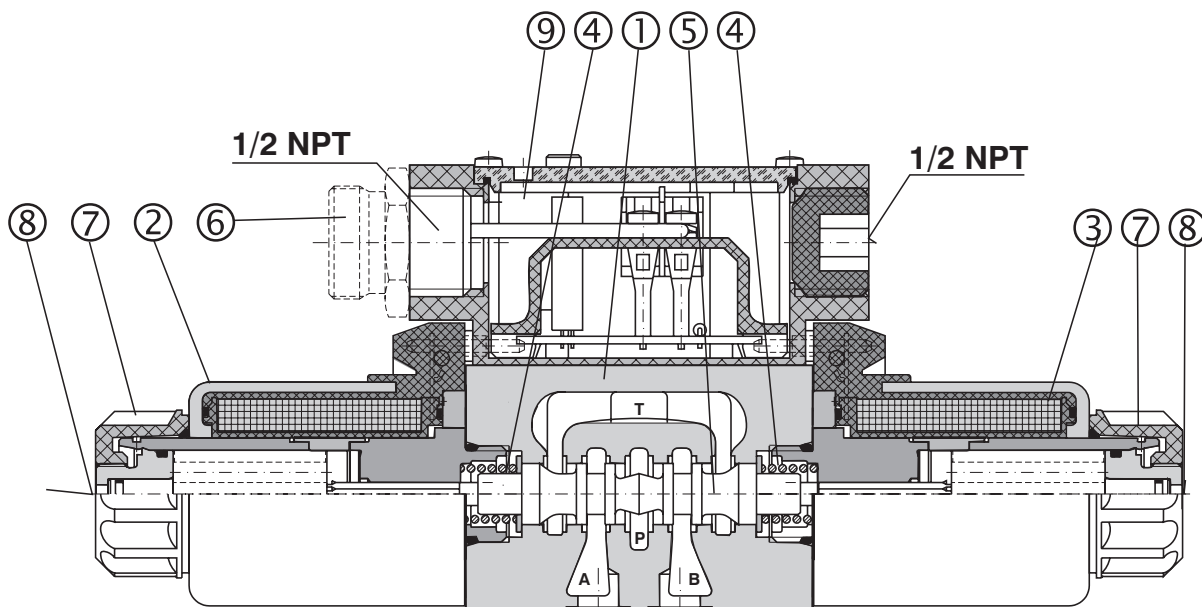

Ordering Code



RPEW4-06 /

**Solenoid Operated
Directional Control Valves
with Wirebox**

Valve Size 06 (D 03)

Number of Valve Positions
two positions **2**
three positions **3**

Spool Symbols
see the table spool symbols

Rated Supply Voltage of Wirebox
(at the wirebox terminals)
12 V DC / 2.64 A  **01200**
24 V DC / 1.32 A  **02400**

** CSA for DC voltage only

Note: For other voltages consult factory
CSA Upon request 

Type of Solenoid Coil for Wiring Box (Plug-In-Coil)

DC solenoid (DC-rectified) **EW1**
DC solenoid with quenching diode **EW2**

Type of Wirebox
Wirebox for DC **K**

Seals
no designation NBR
V FPM (Viton)

Orifice in P Port
no designation without orifice
D1 Ø1,0 mm (0.039 inch)
D2 Ø1,5 mm (0.059 inch)
D3 Ø2,0 mm (0.079 inch)
D4 Ø2,2 mm (0.087 inch)
D5 Ø2,5 mm (0.098 inch)

Spool Speed Control Orifice
no designation without damping
T1 orifice Ø0.7 mm (0.003 inch) in solenoid

Note: For soft shift details / performance see HA 4010

Manual Override
no designation standard
N1 covered with retaining nut
N2 covered with rubber boot

Wirebox Configurations:

- 50** Standard wiring box with 1/2 NPT both ends (Either side can be used for wiring, Remove cover -plug accordingly)
- 51** Standard wiring box with 1/2 NPT both ends and LED diodes (B- side plugged, A - side covert for shipping)
- 52** Wiring box with 3 PIN connector ANSI/B93.55M mounted on A-side (B-side plugged, only for single solenoid valves)
- 53** Wiring box with 3 PIN connector ANSI/B93.55M mounted on B-side (A-side plugged, only for single solenoid valves)
- 54** Wiring box with 3 PIN connector ANSI/B93.55M mounted on A-side with LED diode (B-side plugged, only for single solenoid valves)
- 55** Wiring box with 3 PIN connector ANSI/B93.55M mounted on B-side with LED diode (A-side plugged, only for single solenoid valves)
- 56** Wiring box with 5 PIN connector ANSI/B93.55M mounted on A-side (B-side plugged, only for double solenoid valves)
- 57** Wiring box with 5 PIN connector ANSI/B93.55M mounted on B-side (A-side plugged, only for double solenoid valves)
- 58** Wiring box with 5 PIN connector ANSI/B93.55M mounted on A-side with LED diode (B-side plugged, only for double solenoid valves)
- 59** Wiring box with 5 PIN connector ANSI/B93.55M mounted on B-side with LED diode (A-side plugged, only for double solenoid valves)

Technical Data

Valve size	mm (US)	06 (D 03)
Maximum flow	L/min (GPM)	see p-Q characteristics
Max. operating pressure at porte P, A, B	bar (PSI)	350 (5076)
Max. operating pressure at port T	bar (PSI)	210 (3000)
Pressure drop	bar (PSI)	see Δp-Q characteristics
Hydraulic fluid		Hydraulic oils of power classes (HL, HLP) to DIN 51 524
Fluid temperature range for NBR seals	°C (°F)	-30 ... +80 (-22 ... +176)
Fluid temperature range for FPM seals	°C (°F)	-20 ... +80 (-4 ... +176)
Ambient temperature max.	°C (°F)	+50 (+122)
Viscosity range	mm ² /s (SUS)	20 ... 400 (98 ... 1840)
Maximum degree of fluid contamination		Class 21/18/15 to ISO 4406
Max. allowable voltage variation	%	DC: ± 10 / AC: ± 10
Max. switching frequency	1/h	15 000
Switching time, on: at v=32 mm ² /s (156 SUS)	ms	DC: 30 ... 50
Switching time, off: at v=32 mm ² /s (156 SUS)	ms	DC: 10 ... 50
Duty cycle	%	100
Service life	cycles	10 ⁷
Enclosure type to EN 60 529		IP 65
Weight - valve with 1 solenoid	kg (lbs)	1,3 (2.9)
- valve with 2 solenoids		1,9 (4.2)
Mounting position		unrestricted

Functional Symbols

Type	Symbol	Crossover	Type	Symbol	Crossover
Z11			X25		
C11			Y51		
H11			C51		
P11			Z51		
Y11			H51		
L21			F51		
B11			Z11		
Z21			X11		
F11			C11		
R11			H11		
R21			N11		
A51			F11		
P51			J15		
			J75		

p-Q Characteristics

Measured at $v = 32 \text{ mm}^2/\text{s}$ (156 SUS)

Operating limits for maximum hydraulic power transferred by the directional valve. For respective spool type - see Functional Symbols.

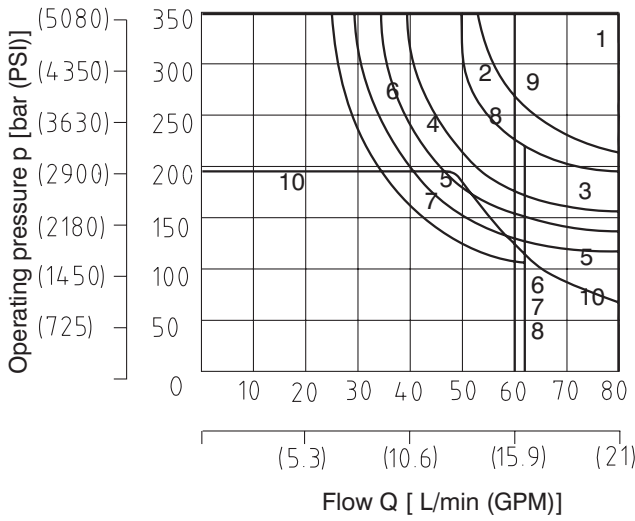

DC		DC		DC	
Z11	1	J75	9	H51	7
C11	6	F11	5	F51	7
H11	3	R11	3	X11	3
P11	1	R21	4	N11	7
Y11	2	A51	5	X25	10
L21	5	P51	1		
B11	8	Y51	2		
J15	1	C51	6		
Z21	1	Z51	1		

Δp -Q Characteristics

Measured at $v = 32 \text{ mm}^2/\text{s}$ (156 SUS)

Pressure drop Δp related to flow rate.

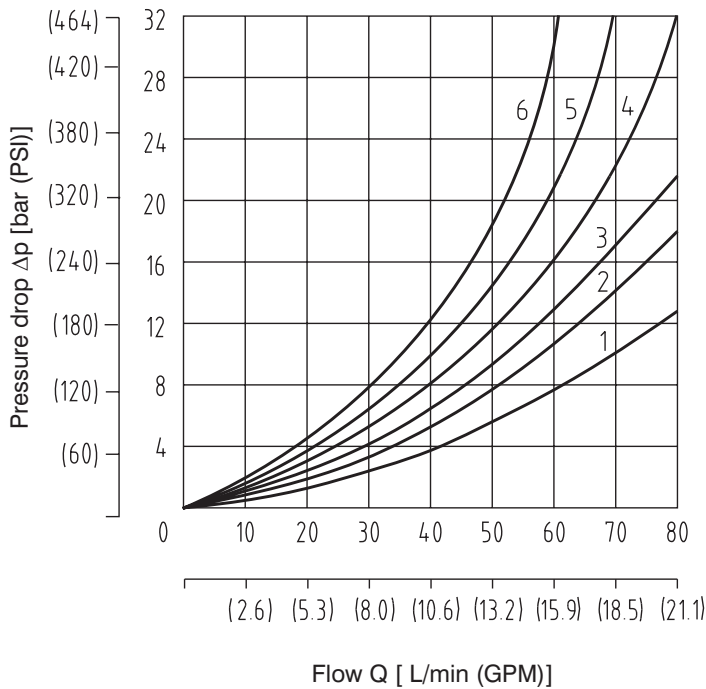

	P-A	P-B	A-T	B-T	P-T
Z11	2	2	3	3	
C11	5	5	5	6	3
H11	2	2	2	3	3
P11	1	1	3	3	
Y11	2	2	2	2	
L21	2	2	3	3	
B11	2	2	3	3	
Z21		2	3		
F11	1	2		3	3
R11	2	2	3	3	
R21	2	2	3	3	
A51	2	2			
P51		1	3		
Y51		2	2		
C51	2			3	4
Z51		2	3		
H51		2	3		
F51		2	3		
X11	2	2	3	3	
N11	2	2	3	3	
J15	2	2	3	3	
J75	2	2			

Valve Dimensions

Dimensions in millimeters and inches

1

Valve with two DC voltage supplied solenoids

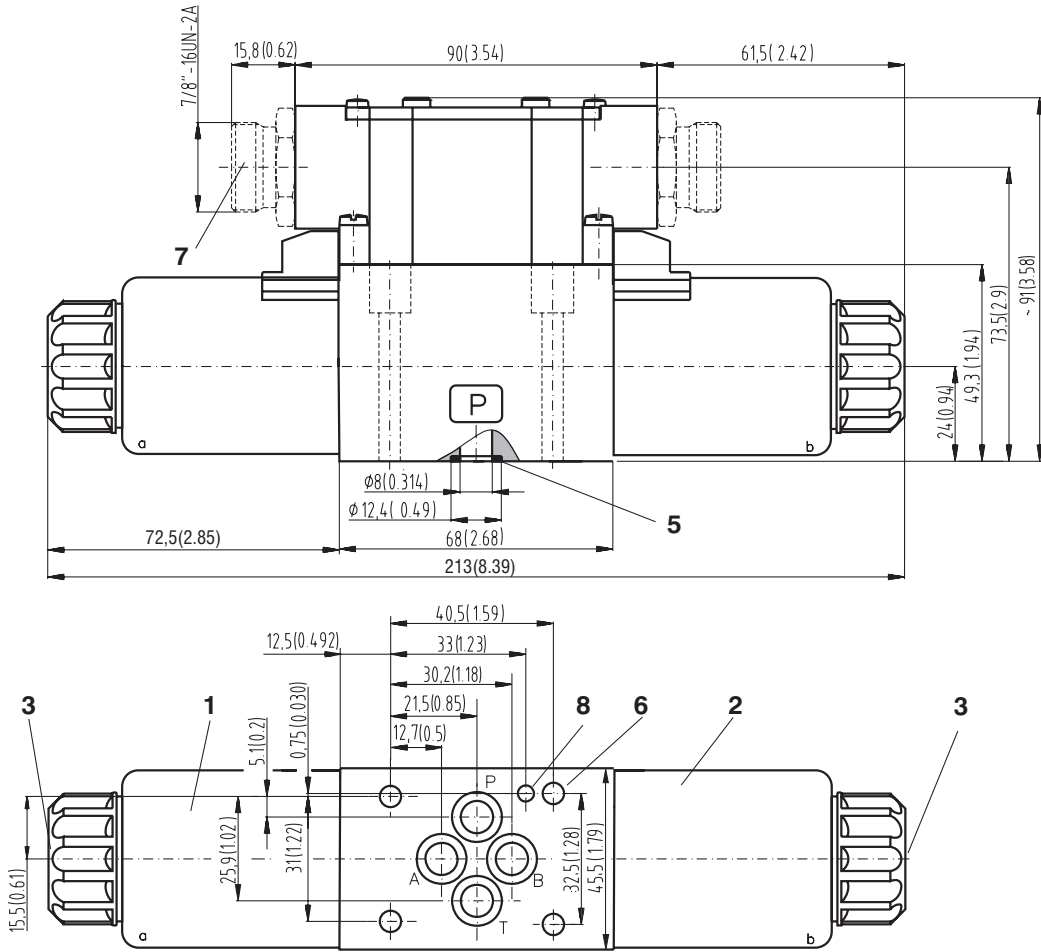

Valve with one (DC) solenoid "a"

Spool symbols R11, R21, A51, P51, Y51, Z51, C51, H51, F51

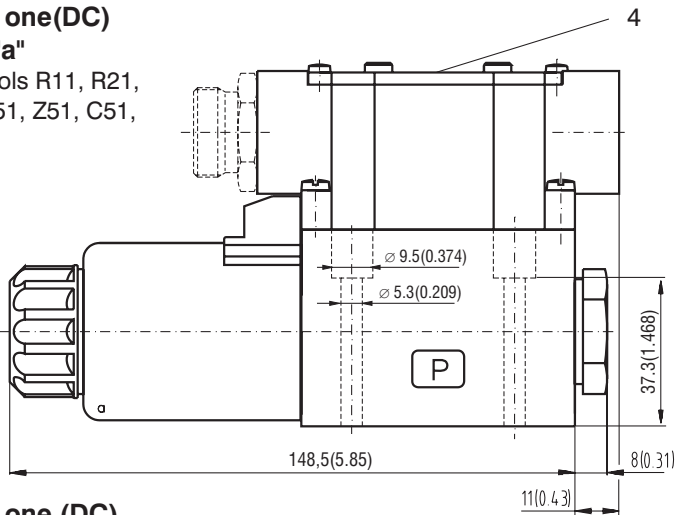

- 1 Solenoid a [(Nut torque 3 Nm (2.21 ft-lbs.))]
- 2 Solenoid b [(Nut torque 3 Nm (2.21 ft-lbs.))]
- 3 Manual override
- 4 Name plate
- 5 Square ring (4 pcs.)
9,25 x 1,68 supplied with valve
- 6 4 mounting holes
- 7 Electrical connector
- 8 Pin Hole

Valve with one (DC) solenoid "b"

Spool symbols X11, Z11, C11, H11, N11, F11

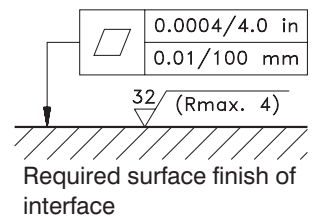
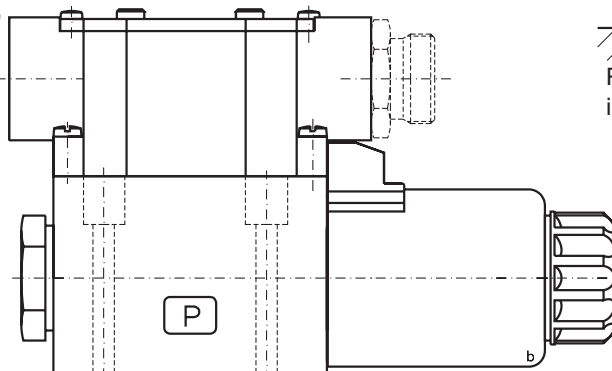

Manual Override

STANDARD

no designation
Dimensions

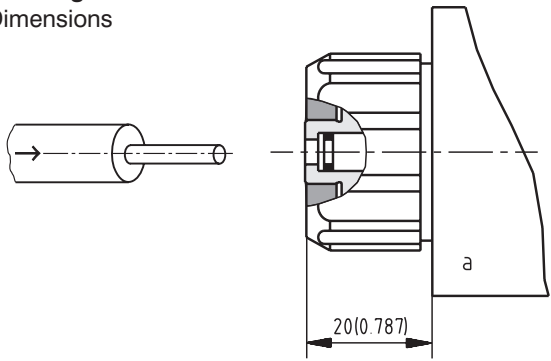

Standard model of the manual override.
Standard retaining nut of the solenoid.

CLOSED NUT

Type **N1** (For DC voltage solenoids only)
Dimensions

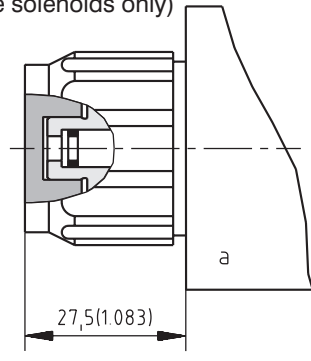

Manual override with retaining nut.
Can be used after removing nut.

RUBBER BOOT

Type **N2** (For DC voltage solenoids only)
Dimensions

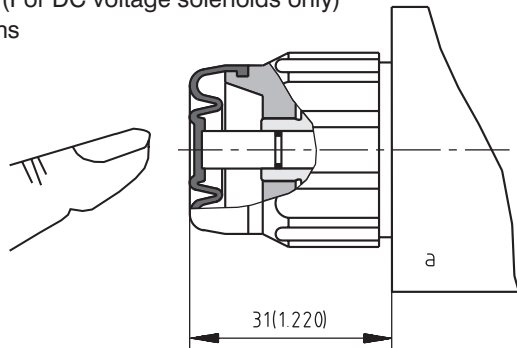

Manual override protected by rubber boot.

Orifice in P-Port

Type	∅D mm(inch)	Dimensions	Description
D1	1,0 (0.039)		P-Port orifices limit the flow into the directional control valve. Attention: When the orifice in P port is additionally mounted the standard used square ring NBR is replaced with O-ring from Viton.
D2	1,5 (0.059)		
D3	2,0 (0.079)		
D4	2,2 (0.087)		
D5	2,5 (0.098)		

Connector - US - Standard - ANSI/B93.55M

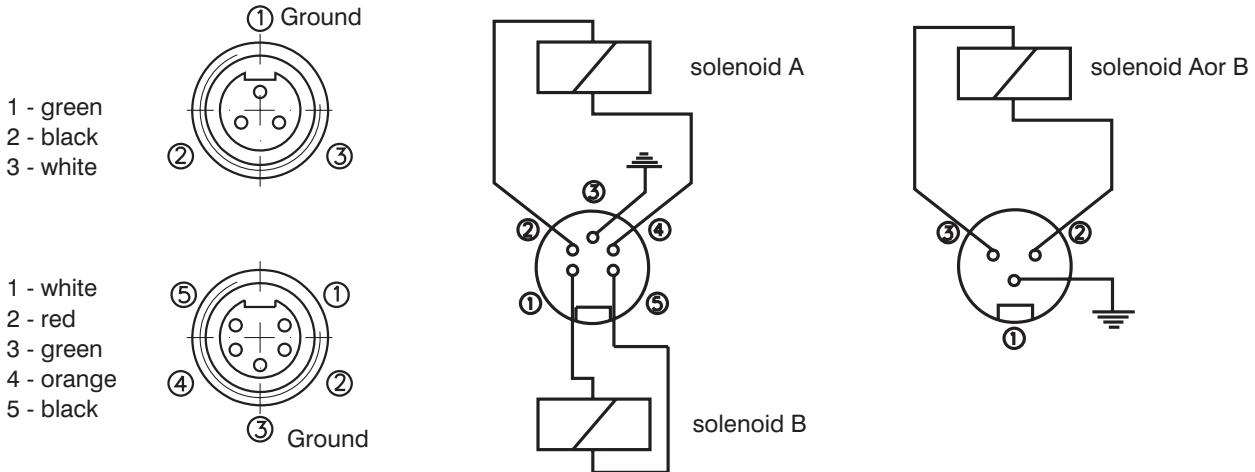

Spare Parts

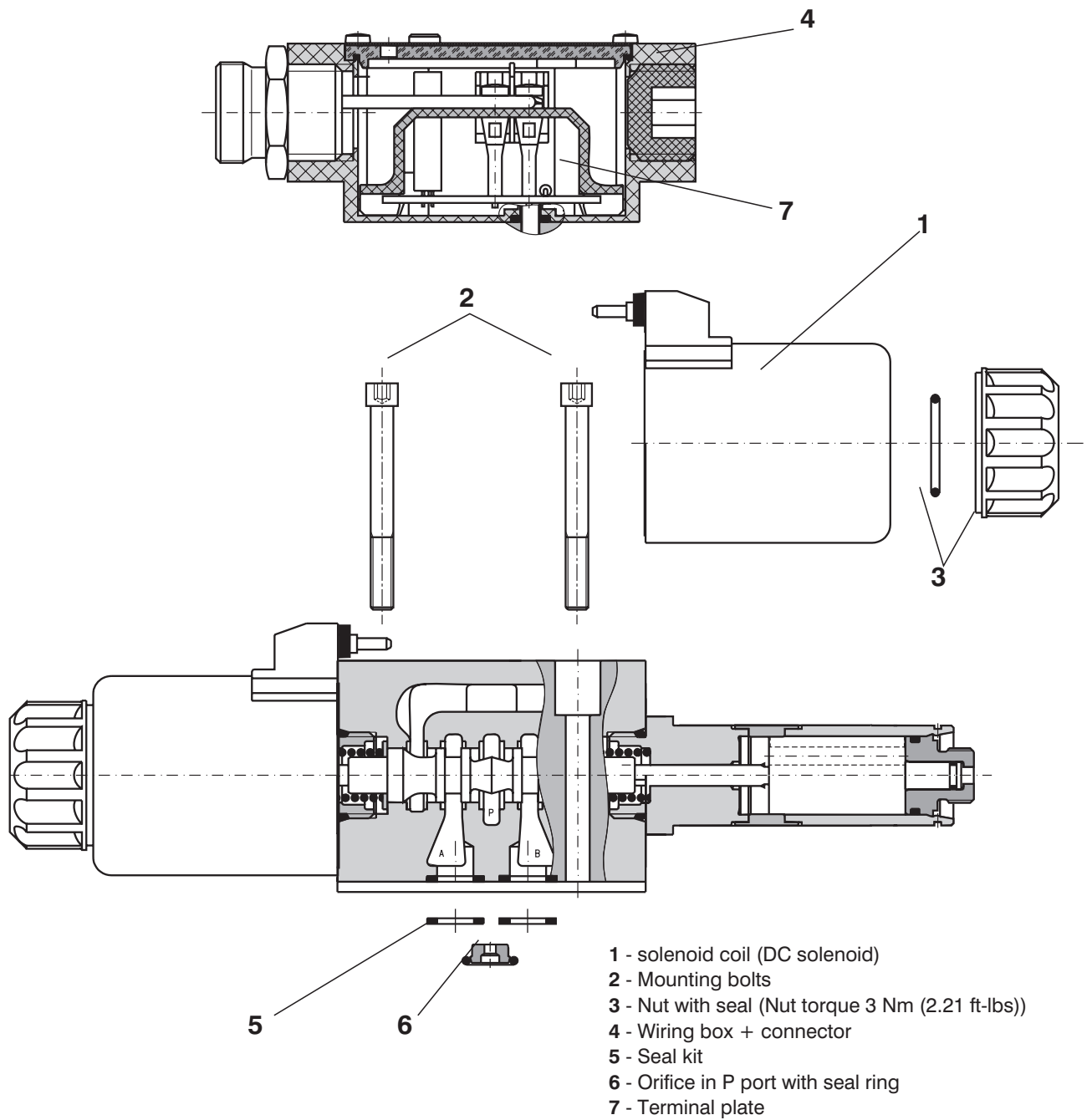

Wiringbox		
Type		Ordering number
Wiring box without terminal plate		24008400
Terminal Plates		
Type		Ordering number
Terminal plate - basic design A+B		16204400
Terminal plate A - basic design		24010800
Terminal plate B - basic design		24008600
Terminal plate 12V DC - lights A+B		16204500
Terminal plate 24V DC - lights A+B		16204600
Terminal plate 12V DC - LED diode A		24008800
Terminal plate 12V DC -LED diode B		24008900
Terminal plate 24V DC - LED diode A		24009100
Terminal plate 24V DC - LED diode B		24009200

Solenoid Coil				
Voltage rating		Type	Ordering number	
01200 DC		EW1	16205100	
*01200 DC		EW1	24154700	
02400 DC		EW1	16205000	
*02400 DC		EW1	24154900	
10600 DC (120V/60Hz rectifier)		EW1	16205200	
01200 DC		EW2	16205400	
02400 DC		EW2	16205500	
Solenoid Retaining Nut with Seal				
Type of the nut		Seal ring	Ordering number	
Standard nut		22 x 2	15844600	
Nut with detent assembly			15844900	
Closed nut			15844700	
Nut with rubber boot			15844800	
Electrical Connector, ANSI/B93.55M				
Type		Ordering number		
3 PIN		24007300		
5 PIN		24007400		
Orifice in P-Port				
Type	ØD mm (inch)	Seal ring	Ordering number	
D1	1,0 (0.039)	9.25 x 1.75	15845600	
D2	1,5 (0.059)		15845700	
D3	2,0 (0.079)		15845800	
D4	2,2 (0.087)		15846000	
D5	2,5 (0.098)		15845900	
Seal Kit				
Type	Dimensions, quantity		Ordering number	
Standard - NBR70	9.25 x 1.68 (4 pcs.)	17 x 1.8 (2 pcs.)	9.25 x 1.75 (1 pc)	21483800
Viton	9.25 x 1.78 (4 pcs.)	17.17 x 1.78 (2 pcs.)		15845400
Bolt Kit (for studs see HA 0030)				
Dimensions, quantity		Bolt torque	Ordering number	
M5 x 45 DIN 912-10.9 (4 pcs.)		8.9 Nm(6.6 ft-lbs)	15845100	
10-24 UNC x 1.75 (4 pcs.)			2 000 107	
* CSA Upon request 				
Caution!				
<ul style="list-style-type: none"> When the distributor contains two electromagnets any of the two electromagnets can be switched on only after the other one switches off. The electromagnets switching time on distributors with locking arrangement must not be shorter than 60 ms. With directional valves with cushioned spool shifting, the switching time must correspond with the shifting time. Distributors with other interconnections than those shown in the catalogue can be supplied on request. The packaging foil can be recycled The transport base plate can be returned to the manufacturer. Mounting screws M5 x 45 DIN 912-10.9 or bolts must be ordered separately. The screws tightening torque is 8.9 Nm (6.6 ft-lbs). The mentioned data only serve to describe the product and in no case are to be understood in terms of law as guaranteed characteristics. 				
ARGO-HYTOS s.r.o. CZ - 543 15 Vrchlaví Tel.: +420-499-403 111 E-mail: info.cz@argo-hytos.com www.argo-hytos.com				

- 4/3, 4/2 way directional control valves
- Cylindrical DC solenoids with removable coils. Electrical connectors can be rotated in three positions 90° apart
- Spool-position sensor optional
- 4 chamber spool - reducing
- Push button manual override
- Installation dimensions to DIN 24 340 / ISO 4401 / CETOP RP121-H
- Subplates see data sheet HA 0002
- CSA Upon request 

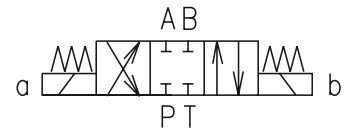

Functional Description

The RPE4-10 directional control valves consist of housing (1), control spool (5), centering springs (4) and operating solenoids (2, 3).

The three-position directional control valves are fitted with two solenoids and two springs. The two position directional control valves have one solenoid and one return spring.

The operating solenoids are DC solenoids and are supplied through connectors (6, 7) without rectifiers. For AC supply the solenoids are provided with rectifiers,

which are integrated directly into the connectors (6, 7) or inside the coil.

By loosening the retaining nut (8), the solenoid can be turned on its axis and locked in three positions 90° apart. Provided that the pressure in T-port does not exceed (25 bar), the spool of the valve can be shifted by manual override (9).

The basic surface treatment of the valve housing (1) is phosphate coated, the operating solenoids (2, 3) are zinc coated.

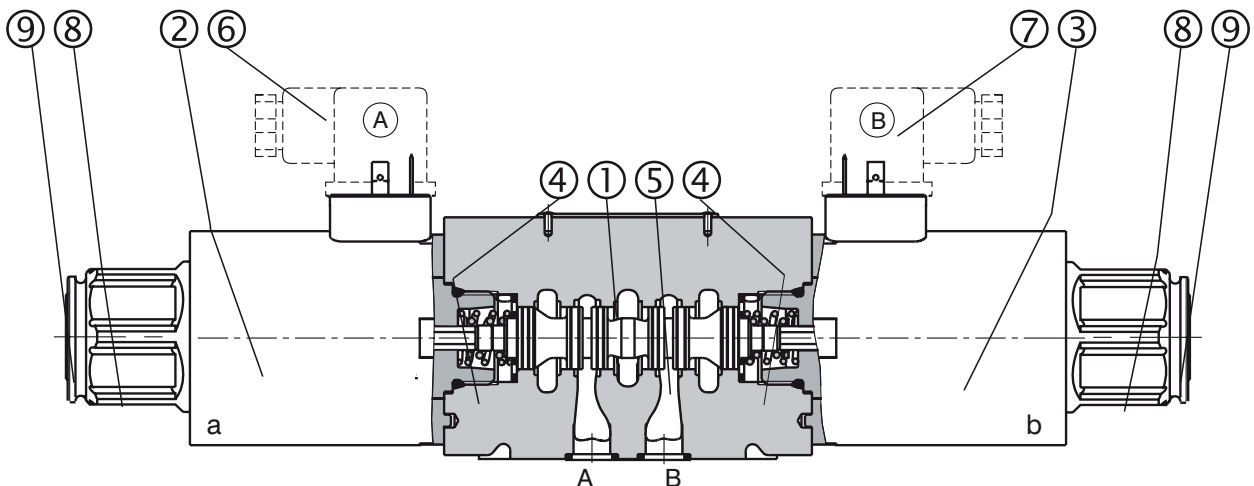

Ordering Code

RPE4-10 /

**Directional Control Valve
Solenoid Operated**

Nominal size

Number of operating positions

two positions
three positions

2
3

Functional symbols

see the table functional symbols

Rated supply voltage of solenoids

(at the coil terminals)

12 V DC / 3.17 A
24 V DC / 1.73 A
205 V DC / 0.20 A
230 V AC / 0.20 A / 50 (60) Hz
120V AC / 60Hz*

01200
02400
20500
23050
 **12060**

The AC coils correspond with E5 type.

CSA Upon request 

Type of the solenoid coil

for the electrical connector, EN 175301-803
with integrated rectifier and for the electrical connector
EN 175301-803

E1
E5

Sensing of the end position

no designation without sensor
S1 normally-open sensor to 50bar
S2 normally-open sensor to 210bar
S4 normally-closed sensor to 50bar

no designation **V** **Seals**
standard (NBR)
Viton (FPM)

no designation **T2** **T3** **Damping**
without damping
with orifice
with throttle screw

no designation **N2** **Manual override**
standard
covered with rubber boot

Note: Connector of the position sensor is not supplied
(see ordering number on page 9)

**FOR PREFERRED TYPES SEE BOLD TYPING IN ORDERING CODE, FUNCTIONAL SYMBOLS
AND TABLE OF PREFERRED TYPES ON PAGE 10**

Technical Data

Nominal size	mm	10	
Maximum flow	L/min	see p-Q characteristics	
Maximum operating pressure at ports P, A, B	bar	350	
Maximum operating pressure at port T	bar	50 for version S1, S4 and 210 for version S2	
Pressure drop	bar	see Δp -Q characteristics	
Hydraulic fluid		Hydraulic oils of power classes (HL, HLP) to DIN 51524	
Fluid temperature range (NBR / Viton)	°C	-30 ... +80 / -20 ... +80	
Ambient temperature max.	°C	+50	
Viscosity range	mm ² /s	20 ... 400	
Maximum degree of fluid contamination		Class 21/18/15 to ISO 4406	
Maximum allowable voltage variation	%	AC: ± 10	DC: ± 10
Maximum switching frequency	1/h	15 000	
Switching time, ON; at $v = 32 \text{ mm}^2/\text{s}$	ms	AC: 50 ... 330	DC: 50 ... 120
Switching time, OFF; at $v = 32 \text{ mm}^2/\text{s}$	ms	AC: 100 ... 300	DC: 30 ... 90
Duty cycle	%	100	
Service life	cycles	10^7	
Enclosure type to EN 60529		IP 65	
Weight - valve with 1 solenoid - valve with 2 solenoids	kg	3.9 5.4	
Mounting position		unrestricted	

Functional Symbols

Designation	Symbol	Interposition	Designation	Symbol	Interposition
Z11			P51		
C11			Y51		
H11			C51		
P11			B51		
Y11			Z51		
L21			H51		
B11			X11		
C21			C11		
R11			H11		
R21			J15		
A51			J75		

p-Q Characteristics

Measured at $v = 32 \text{ mm}^2/\text{s}$

Operating limits for maximum hydraulic power transferred by the directional valve. For respective spool type - see functional symbols. The power curves hold true for symmetrical valve flows (e.g. flows in directions P-A and B-T are identical). In case of an asymmetric flow, the power curves can lie substantially lower. In such cases we highly recommend to consult the respective power curve with the valve manufacture.

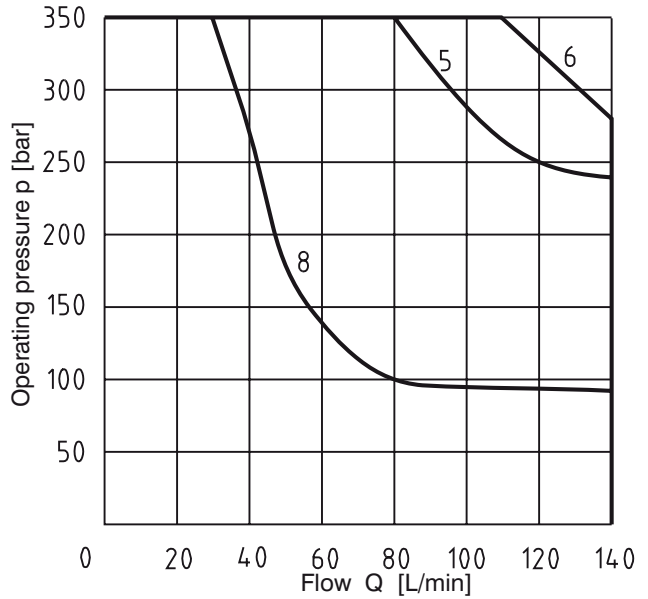
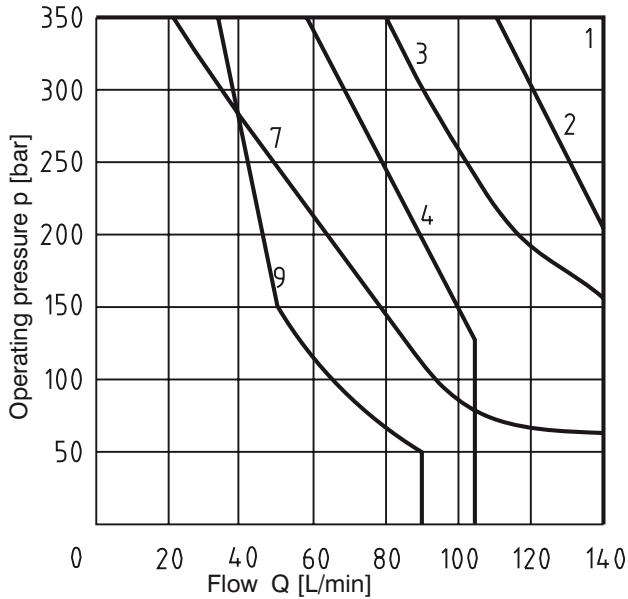

Z11	Z51	H11	H51	P11	P51	Y11	Y51	C11	C51	R11	X11	B11	B51	L21	R21	J15	J75	A51	C21
1	1	1	1	1	1	5	5	3	3	2	2	4	4	7	2	6	6	8	9

Δp -Q Characteristics

Measured at $v = 32 \text{ mm}^2/\text{s}$

Pressure drop Δp related to flow rate.

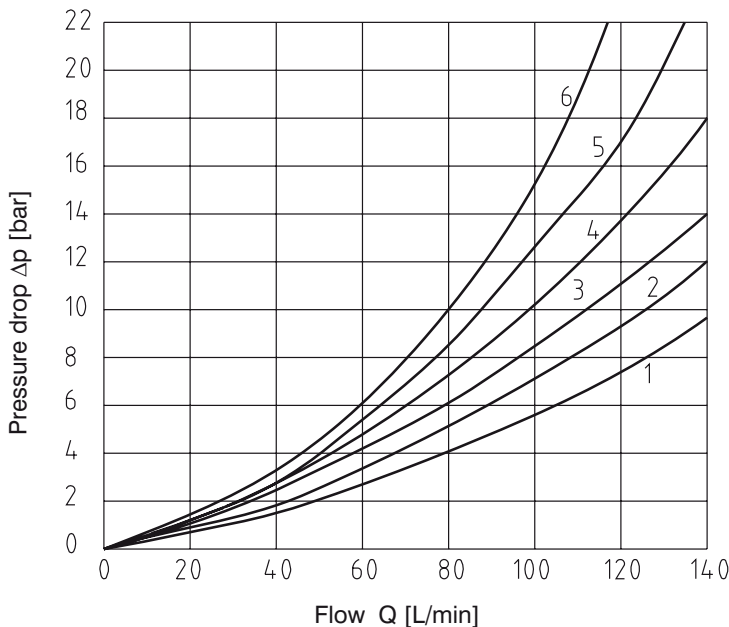

	P-A	P-B	A-T	B-T	P-T
Z11	1	1	2	2	
Z51		1	2		
H11	1	1	2	2	1
H51		1	2		1
P11	1	1	2	2	
P51		1	2		
Y11	1	1	2	2	
Y51		1	2		
C11	4	3	4	5	1
C51	4			5	1
R11	1	1	2	2	
X11	1	1	2	2	
B11	1	1	2	2	
B51		1	2		
L21	1	1	1	2	2
R21	1	1	1	3	
J15	1	1	2	3	
J75	1	1			
A51	1	1			
C21	6	6	6	6	4

Valve Dimensions

Dimensions in millimetres

Valve with two solenoids

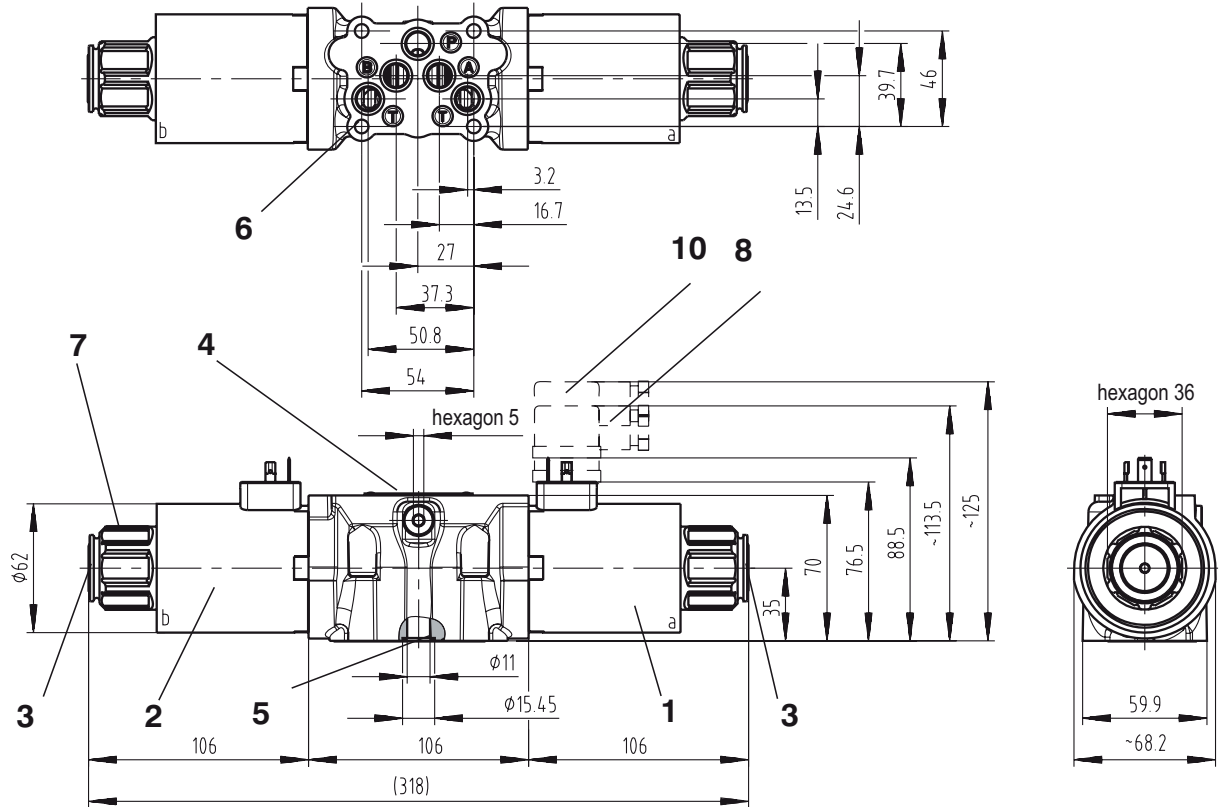

Valve with one solenoid "a"

Functional symbols R11, R21, Y51, C51, Z51, H51,

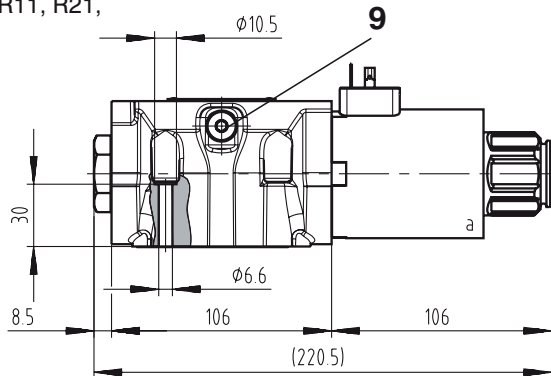

Valve with one solenoid "b"

Functional symbols C11, H11

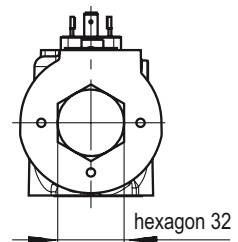
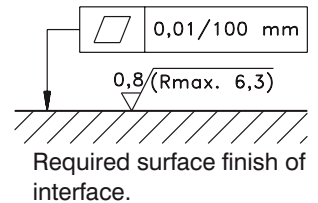
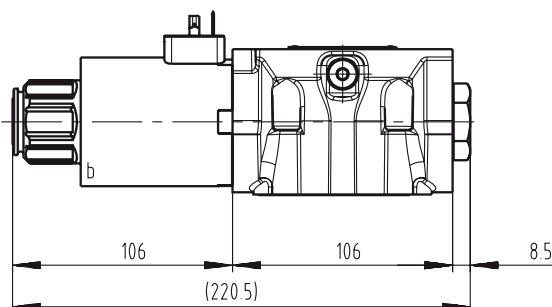

- 1 Solenoid a
- 2 Solenoid b
- 3 Manual override
- 4 Name plate
- 5 Square ring 12,42 x 1,68 (5 pcs.) supplied with valve
- 6 4 mounting holes
- 7 Retaining nut of the solenoid
- 8 Electrical connector, EN 175301-803
- 9 Throttle screw
- 10 Space required to remove connector

Type of the Solenoid Coil

E1

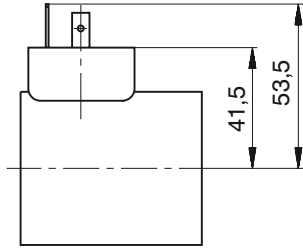

Solenoid coil with terminal for the electrical connector, EN 175301-803

E5

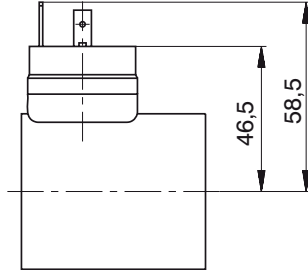

Solenoid coil with integrated rectifier and terminal for electrical connector, EN 175301-803

Manual Override

Standard

Rubber boot

Without designation
Dimensions

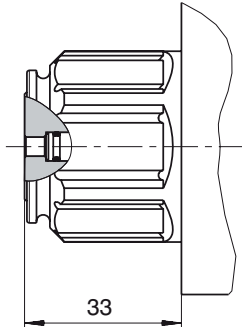
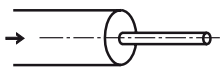

Description:
Standard model of the manual override.
Standard retaining nut of the solenoid.

Designation **N2**
Dimensions

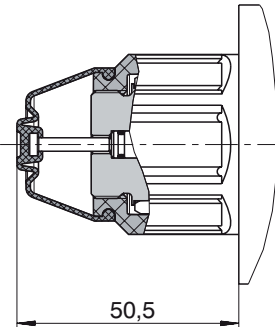
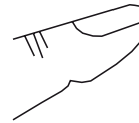

Description:
Manual override protected by rubber boot.

Soft Shifting Spool Options Delay Time

T2 - Nozzle $\varnothing 0,6$

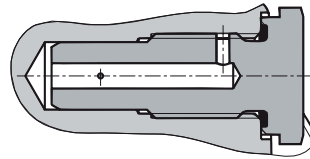
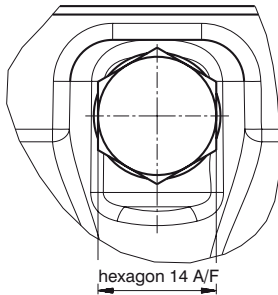

The orifice extends the valve shifting time.

Switching times

Switching time, on and off	ms	120 ... 350
----------------------------	----	-------------

T3 - Throttle Screw

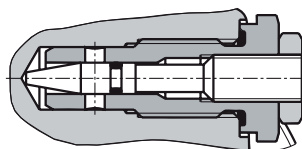
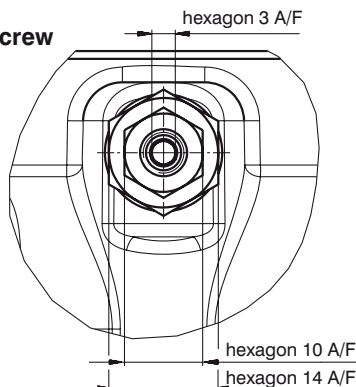

The control orifice allows for stepless adjustment of the valve shifting time.

Switching times

Switching time, on and off	ms	30 ... 2000
----------------------------	----	-------------

Spool Position Sensor

S1, S2 - Circuit diagram of the normally-open sensor

S4 - Circuit diagram of the normally-closed sensor

The proximity sensor transforms the spool position into an electrical step signal. It can be used with directional control valves with one or two solenoids.

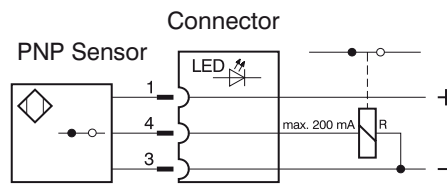
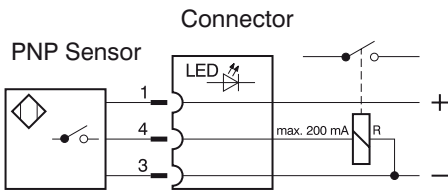

Technical Data of the Sensor

		S1, S4	S2
Rated power supply voltage	V		24 DC
Power supply voltage range	V		10 ... 30 DC
Rated current	mA		200
Enclosure type of sensor to EN 60529			IP 67
Max. operating pressure	bar	50	210
Switching frequency	Hz		1000
Ambient temperature range	°C		-25 ... +80

Technical Data of the Connector

Power supply voltage range	V	10 ... 30 DC
Ambient temperature range	°C	-25 ... +80
Indication		yellow LED

Two-Position Directional Control Valve

Dimensions in millimeters

Signal of solenoid a (b)	Signal of sensor Sa (Sb)		LED	
	S1, S2 - normally-open	S4 - normally-closed	S1, S2	S4
0	1	0	ON	OFF
1	0	1	OFF	ON

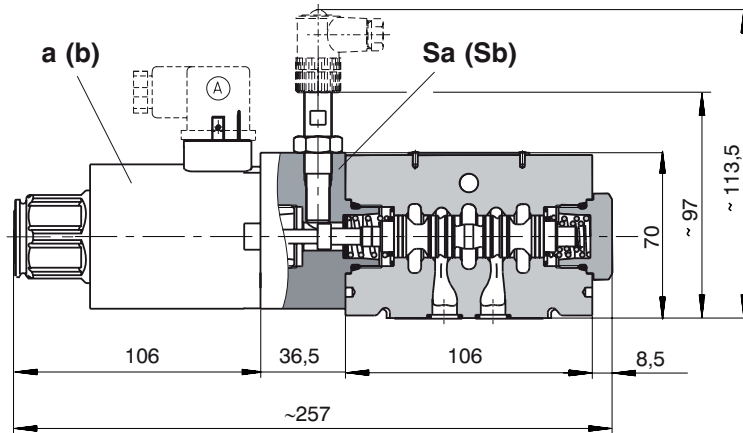

Three-Position Directional Control Valve

Dimensions in millimeters

Signal of solenoid		Signal of sensor Sa (Sb)				LED			
a	b	S1, S2 - normally-open		S4 - normally-closed		S1, S2		S4	
		Sa	Sb	Sa	Sb	Sa - LED	Sb - LED	Sa - LED	Sb - LED
0	0	1	1	0	0	ON	ON	OFF	OFF
1	0	0	1	1	0	OFF	ON	ON	OFF

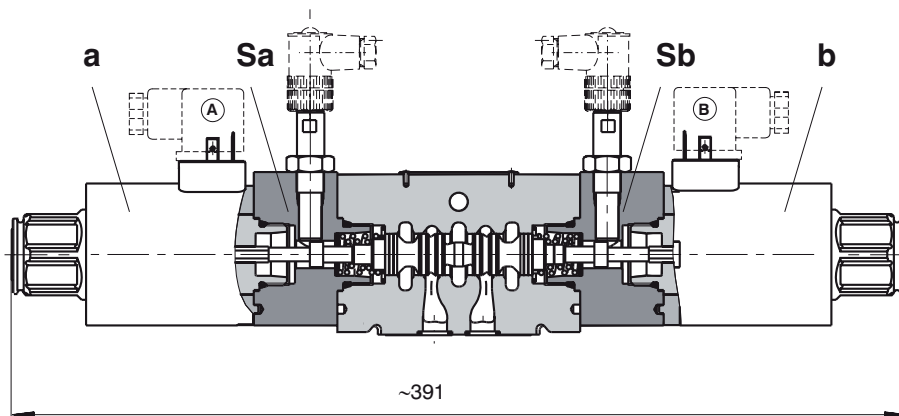

Spare Parts

1

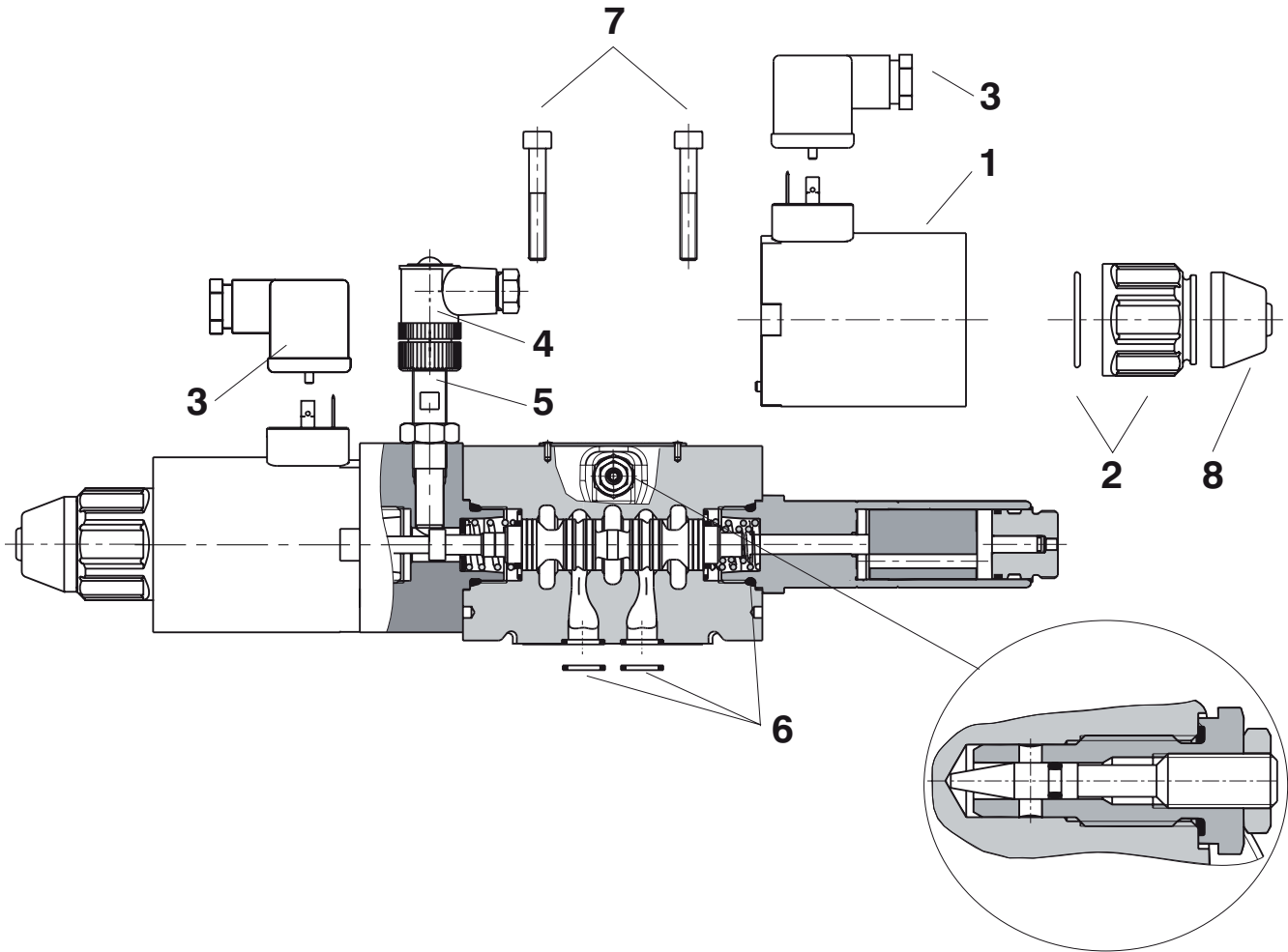

- 1 Solenoid coil
- 2 Nut with seal
- 3 Electrical connector
- 4 Connector of position sensor with LED
- 5 Sensor
- 6 Seal kit
- 7 Mounting bolts
- 8 Rubber cap with manual override

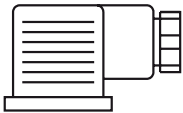
Solenoid coil				
Type designation of the coil voltage	Type of the coil			
	E1	E5		
	Ordering number			
01200	16195700			
02400	16196100			
20500	23898000			
23050		16195100		
12060		16195000		
Solenoid retaining nut with seal				
Type of the nut	Seal ring	Ordering number		
Standard nut	30 x 2	15900800		
Rubber cap with manual override		15900900		
Connector of position sensor				
Type designation	Model	Max. input voltage	Ordering number	
K02	connector of position sensor with LED	10...30 V DC	17364800	
S1	normally-open sensor	10...30 V DC	405111129213	
S2	normally-open sensor	10...30 V DC	18838900	
S4	normally-clsd sensor	10...30 V DC	20725300	
Seal kit				
Type	Dimensions		Ordering number	
	Square ring	O-ring		
Standard NBR70	12,42 x 1,68 (5 pcs.), 11,9 x 8,4 x 1 (1 pc.)	23,81 x 2,62 (2 pcs.), 1,8 x 1 (1 pc.)	15847500	
Viton	12,42 x 1,68 (5 pcs.), 11,9 x 8,4 x 1 (1 pc.)	23,47 x 2,62 (2 pcs.), 1,8 x 1 (1 pc.)	15847800	
Mounting bolts				
Dimensions	Tightening torque	Ordering number		
M6 x 40 DIN 912-10.9 (4 pcs.)	14+2 Nm	15847700		
Soft Shift Conversion Kit				
T2	10 Nm	15901200		
T3	10 Nm	15901300		
Electrical connector, EN 175301-803				
Type designation	Connector A grey	Connector B black		
	Ordering number			
K1	16202200	16202100		
K5	16202600	16202500		
K2	16202800	16202700		
K3	16202400	16202300		
K4	16203000	16202900		
Electrical Connector, EN 175301-803				
K1	Connector B (black)	without rectifier - M16x1.5 (bushing bore \varnothing 6-8 mm)	230 V AC/DC	
	Connector A (grey)			
K5	Connector B (black)	without rectifier - M16x1.5 (bushing bore \varnothing 4-6 mm)	230 V AC/DC	
	Connector A (grey)			
K2	Connector B (black)	without rectifier with LED and quenching diode - M16x1.5 (bushing bore \varnothing 6-8 mm)	12 ... 24 V DC	
	Connector A (grey)			
K3	Connector B (black)	with rectifier - M16x1.5 (bushing bore \varnothing 6-8 mm)	230 V AC	
	Connector A (grey)			
K4	Connector B (black)	with rectifier with LED and quenching diode - M16x1.5 (bushing bore \varnothing 6-8 mm)	230 V AC	
Recommended solenoid coils used with electrical connector with rectifiers - type designation K3, K4				
Rated supply source voltage (permissible rated voltage variation ± 10 %)		Type designation of the solenoid voltage		
230 V AC / 0.17 A / 50 (60) Hz		20500		

Preferred Types

Type	Ordering number	Type	Ordering number
RPE4-103Z11	15888500	RPE4-103Z11/02400E1	15889500
RPE4-102Z51	15892000	RPE4-102Z51/02400E1	15892300
RPE4-103C11	15888700	RPE4-103C11/02400E1	15890000
RPE4-102C51	15892100	RPE4-102C51/02400E1	15892500
RPE4-103H11	15889000	RPE4-103H11/02400E1	15892700
RPE4-103Y11	15888900	RPE4-103Y11/02400E1	15893100
RPE4-102R11	15889100	RPE4-102R11/02400E1	15890700
RPE4-102R21	15889200	RPE4-102R21/02400E1	15893400
RPE4-102Y51	15892200	RPE4-102Y51/02400E1	15893700
RPE4-103Z11/01200E1	15891600	RPE4-103Z11/23050E5	21867800
RPE4-102Z51/01200E1	15891200	RPE4-102Z51/23050E5	21868300
RPE4-103C11/01200E1	15891700	RPE4-103C11/23050E5	21868500
RPE4-102C51/01200E1	15891500	RPE4-102C51/23050E5	21868800
RPE4-103H11/01200E1	15891000	RPE4-103H11/23050E5	21862100
RPE4-103Y11/01200E1	15890400	RPE4-103Y11/23050E5	21868900
RPE4-102R11/01200E1	15891900	RPE4-102R11/23050E5	21869400
RPE4-102R21/01200E1	15891300	RPE4-102R21/23050E5	21869900
RPE4-102Y51/01200E1	15891400	RPE4-102Z51/23050E5	21870100

Caution!

- In the case of directional valves with two solenoids, any of the solenoids may be energized, but only after switching off the other.
- Directional valves with other functional symbols as those shown in the table, please consult with the manufacturer.
- The packing foil is recyclable.
- The protective plate can be returned to manufacturer.
- Mounting bolts M6 x 40 DIN 912-10.9 or studs must be ordered separately.
- The technical information regarding the product presented in this catalogue is for descriptive purposes only. It should not be construed in any case as a guaranteed representation of the product properties in the sense of the law.
- For RPEW4-10 with CSA only: Use supply wires suitable for at least 75°C.

ARGO-HYTOS s.r.o. CZ - 543 15 Vrchlábí
 Tel.: +420-499-403 111
 E-mail: info.cz@argo-hytos.com
 www.argo-hytos.com

- 4/3, 4/2 way directional control valves
- Four-land spool - reduced functional dependence on fluid viscosity
- Push button manual override
- Installation dimensions to DIN 24 340 / ISO 4401 / CETOP RP121-H
- Subplates see data sheet HU 0002
- CSA Upon request

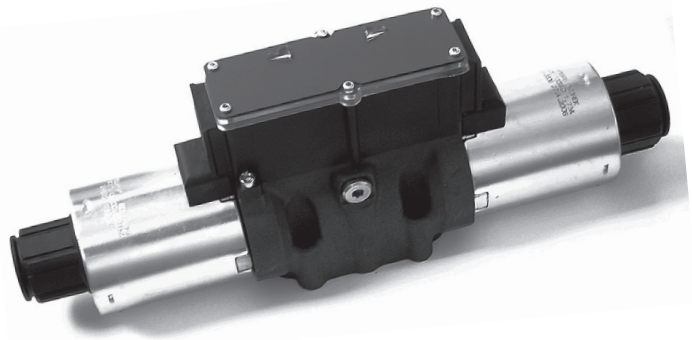
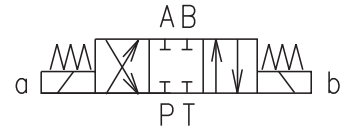

Functional Description

The RPEW4 directional control valves consist of housing (1), a control spool (5) with two centering springs (4) and cylindrical operating solenoids (2, 3), electric wirebox (9) and connector (6).

The three-position directional control valves are fitted with two solenoids and two springs. Two-position directional control valves have either one solenoid and one return spring or two solenoids and a detent assembly.

The solenoids are supplied with DC and AC - voltage through the 1/2 NPT Ports on the wirebox (optional on both sides) or through Connector Item (3 - Pin single solenoid, 5 - Pin - double solenoid) see wiring diagram

(page 7). The wires are connected to a terminal plate inside the wirebox. Optional lights are installed on this terminal plate for shift indication. The lights are visible as raised arrows on the valve label. The solenoids are retained by the Nut (7) and plug-in to the wirebox. Plug-in design allows easy removal without wire change. In the case of solenoid malfunction or power failure, the spool of the valve can be shifted by manual override (8), provided the pressure in T- port does not exceed 25 bar (363 PSI).

The valve housing (1) is phosphate coated and the solenoids (2, 3) are zinc coated.

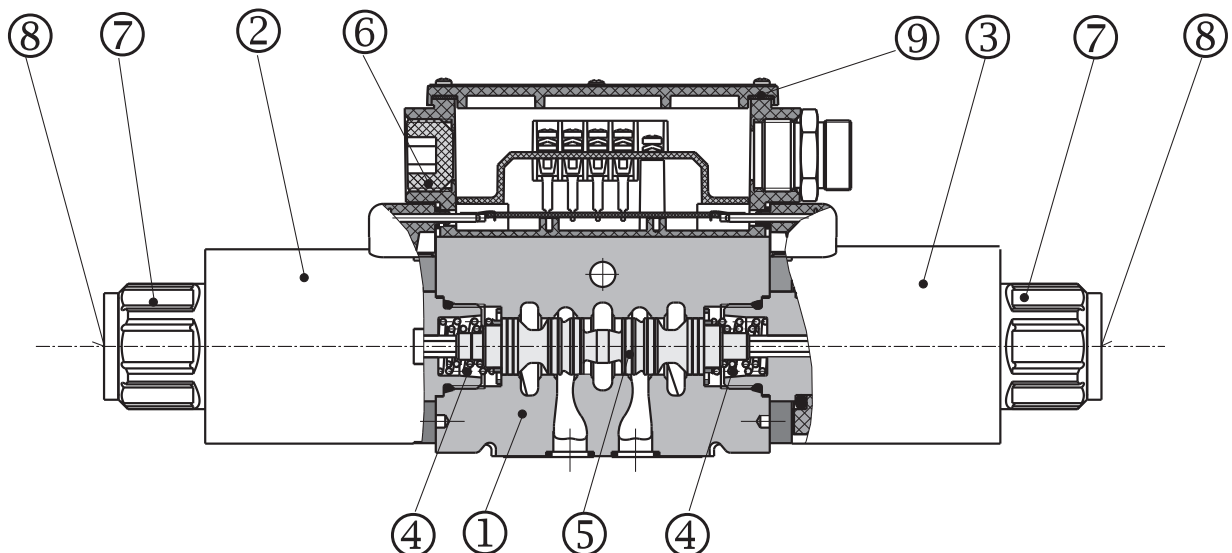

Ordering Code

RPEW4 - 10 /

Solenoid Operated Directional Control Valve with Wirebox

Valve Size 10 (05)

Number of Valve Positions

two positions **2**
three positions **3**

Functional symbols

see the table functional symbols

Rated Supply Voltage of Wirebox (at the wirebox terminals)

12 V DC / 2.64 A **01200**
24 V DC / 1.32 A **02400**
120V AC / 60Hz*  **12060**

* DC coils with rectifier in wirebox only type of Wirebox R

Note: For other voltages consult factory

Type of Solenoid Coil for Wiring Box (Plug-In-Coil)

DC solenoid (DC and AC - rectified) **EW1**

Type of Wirebox

Wirebox for DC
Wirebox AC rectified (rectifier in wirebox)

**K
R**

no designation
V

Seals
NBR
FPM (Viton)

no designation
T2
T3

Damping
without damping
nozzle
throttle screw

no designation
N2

Manual override
standard
covered with rubber boot

Wirebox Configurations:

- 50** Standard wiring box with 1/2 NPT both ends (Either side can be used for wiring, Remove cover -plug accordingly)
- 51** Standard wiring box with 1/2 NPT both ends and LED diodes (B- side plugged, A - side covert for shipping)
- 52** Wiring box with 3 PIN connector ANSI/B93.55M mounted on A-side (B-side plugged, only for single solenoid valves)
- 53** Wiring box with 3 PIN connector ANSI/B93.55M mounted on B-side (A-side plugged, only for single solenoid valves)
- 54** Wiring box with 3 PIN connector ANSI/B93.55M mounted on A-side with LED diode (B-side plugged, only for single solenoid valves)
- 55** Wiring box with 3 PIN connector ANSI/B93.55M mounted on B-side with LED diode (A-side plugged, only for single solenoid valves)
- 56** Wiring box with 5 PIN connector ANSI/B93.55M mounted on A-side (B-side plugged, only for double solenoid valves)
- 57** Wiring box with 5 PIN connector ANSI/B93.55M mounted on B-side (A-side plugged, only for double solenoid valves)
- 58** Wiring box with 5 PIN connector ANSI/B93.55M mounted on A-side with ILED diode (B-side plugged, only for double solenoid valves)
- 59** Wiring box with 5 PIN connector ANSI/B93.55M mounted on B-side with LED diode (A-side plugged, only for double solenoid valves)

CSA Upon request 

Technical Data

Valve size	mm (US)	10 (D 05)	
Maximum flow	L/min (GPM)	see p-Q characteristics	
Maximum operating pressure at ports P, A, B	bar (PSI)	350 (5076)	
Maximum operating pressure at port T	bar (PSI)	210 (3050)	
Pressure drop	bar (PSI)	see Δp-Q characteristics	
Hydraulic fluid		Hydraulic oils of power classes (HL, HLP) to DIN 51524	
Fluid temperature range (NBR / Viton)	°C (°F)	-30 ... +80 (-22 ... +176) / -20 ... +80 (-4 ... +176)	
Ambient temperature max.	°C (°F)	+50 (+122)	
Viscosity range	mm ² /s (SUS)	20 ... 400 (98 ... 1840)	
Maximum degree of fluid contamination		Class 18/15 to ISO 4406. A filter with a retention rate β ₁₀ ≥ 75 is recommended.	
Maximum allowable voltage variation	%	AC: ±10	DC: ±10
Maximum switching frequency	1/h	15 000	
Switching time, ON; at v = 32 mm ² /s (156 SUS)	ms	AC: 50 ... 330	DC: 50 ... 120
Switching time, OFF; at v = 32 mm ² /s (156 SUS)	ms	AC: 100 ... 300	DC: 30 ... 90
Duty cycle	%	100	
Service life	cycles	10 ⁷	
Enclosure type to EN 60529		IP 65	
Weight - valve with 1 solenoid - valve with 2 solenoids	kg (lbs)	3.9 (8.60) 5.4 (11.90)	
Mounting position		unrestricted	

Spool Symbols

Designation	Symbol	Interposition	Designation	Symbol	Interposition
Z11			P51		
C11			Y51		
H11			C51		
P11			B51		
Y11			Z51		
L21			H51		
B11			X11		
C21			C11		
R11			H11		
R21			J15		
A51			J75		

p-Q Characteristics

Measured at $v = 32 \text{ mm}^2/\text{s}$ (156 SUS)

Operating limits for maximum hydraulic power transferred by the directional valve. For respective spool type - see spool symbols. The power curves hold true for symmetrical valve flows (e.g. flows in directions P-A and B-T are identical). In case of an asymmetric flow, the power curves can lie substantially lower. In such cases we highly recommend to consult the respective power curve with the valve manufacture.

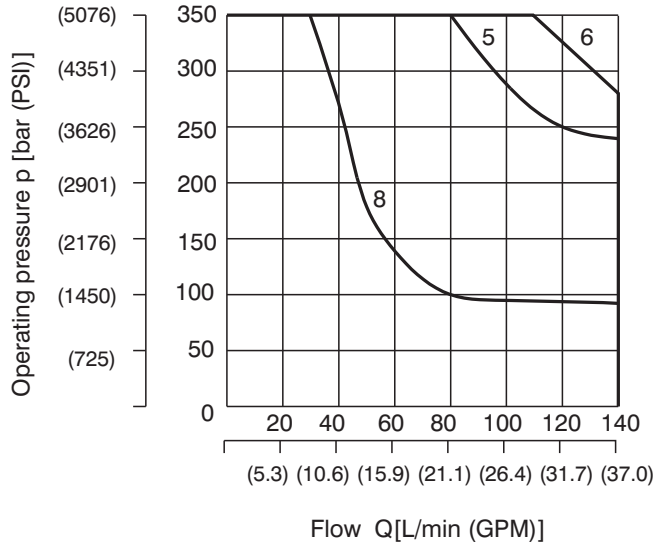
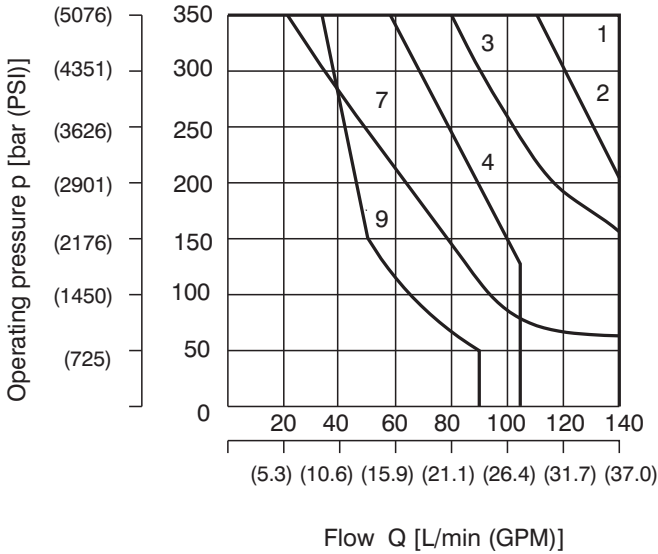

Z11	Z51	H11	H51	P11	P51	Y11	Y51	C11	C51	R11	X11	B11	B51	L21	R21	J15	J75	A51	C21
1	1	1	1	1	1	5	5	3	3	2	2	4	4	7	2	6	6	8	9

Δp-Q Characteristics

Measured at $v = 32 \text{ mm}^2/\text{s}$ (156 SUS)

Pressure drop Δp related to flow rate.

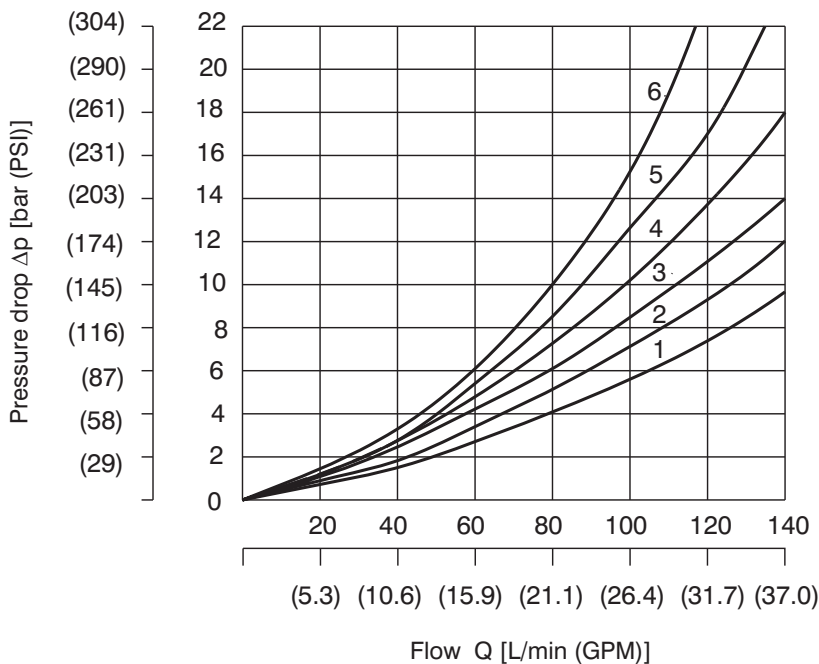

	P-A	P-B	A-T	B-T	P-T
Z11	1	1	2	2	
Z51		1	2		
H11	1	1	2	2	1
H51		1	2		1
P11	1	1	2	2	
P51		1	2		
Y11	1	1	2	2	
Y51		1	2		
C11	4	3	4	5	1
C51	4			5	1
R11	1	1	2	2	
X11	1	1	2	2	
B11	1	1	2	2	
B51		1	2		
L21	1	1	1	2	2
R21	1	1	1	3	
J15	1	2	2	3	
J75	1	1			
A51	1	1			
C21	6	6	6	6	4

Valve Dimensions

Dimensions in millimeters (inches)

Valve with two solenoids

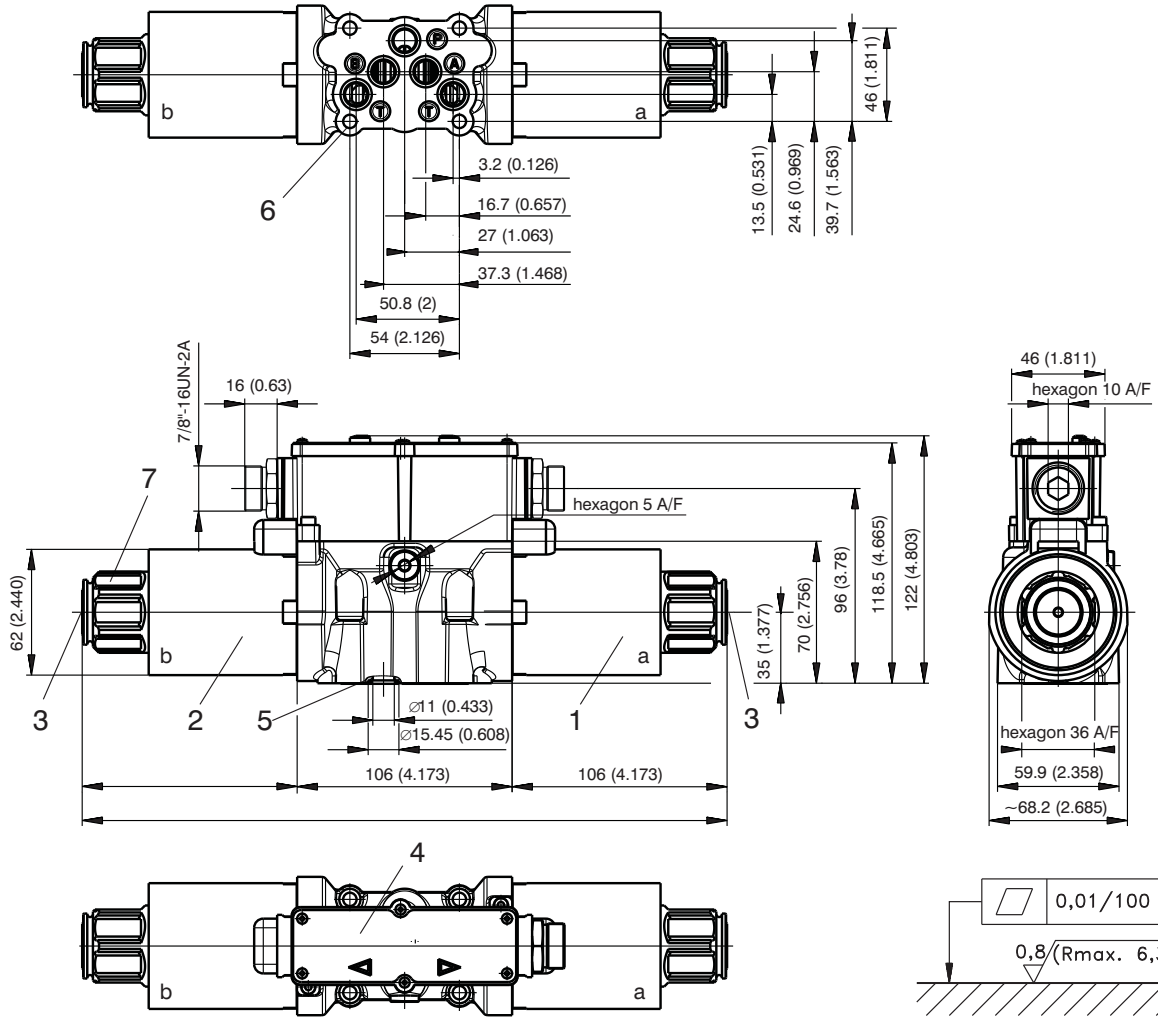

Valve with one solenoid a

Functional symbols R11, R21, Y51, C51, Z51, H51,

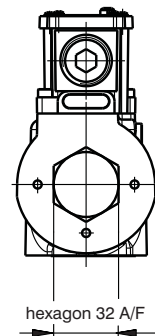
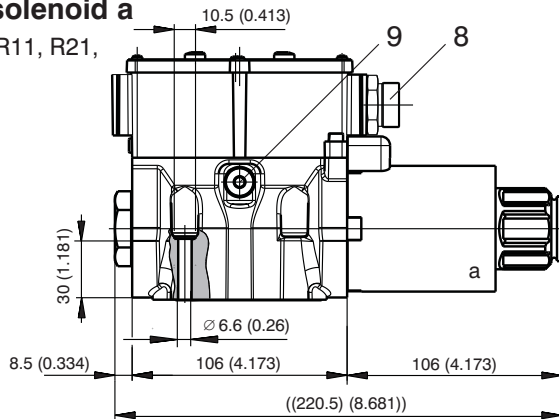

Valve with one solenoid b

Functional symbols C11, H11

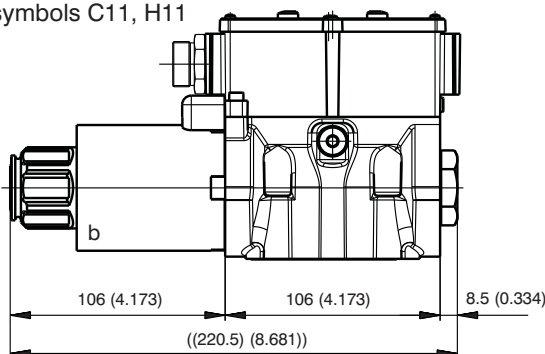

- 1 Solenoid a (Nut torque 6Nm)
- 2 Solenoid b (Nut torque 6Nm)
- 3 Manual override
- 4 Name plate
- 5 Square ring 12.42 x 1.68 (5 pcs.) supplied with valve
- 6 4 mounting holes
- 7 Retaining nut of the solenoid
- 8 Electrical connector

Manual Override

1

Standard

No designation
Dimensions

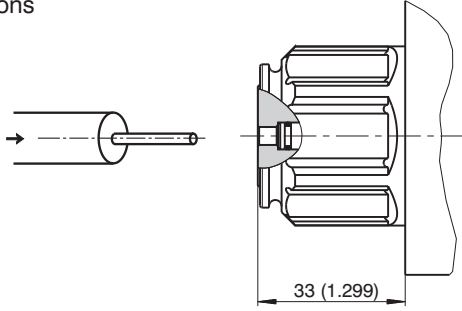

Standard model of the manual override.
Standard retaining nut of the solenoid.

Rubber boot

Type **N2**
Dimensions

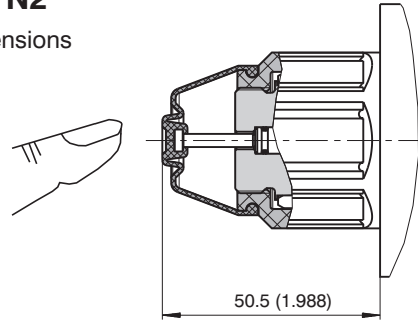

Manual override protected by the rubber boot.

Soft Shifting Spool Options Delay Time

T2 - Nozzle $\varnothing 0.157 (0.6)$

The orifice extends the valve shifting time.

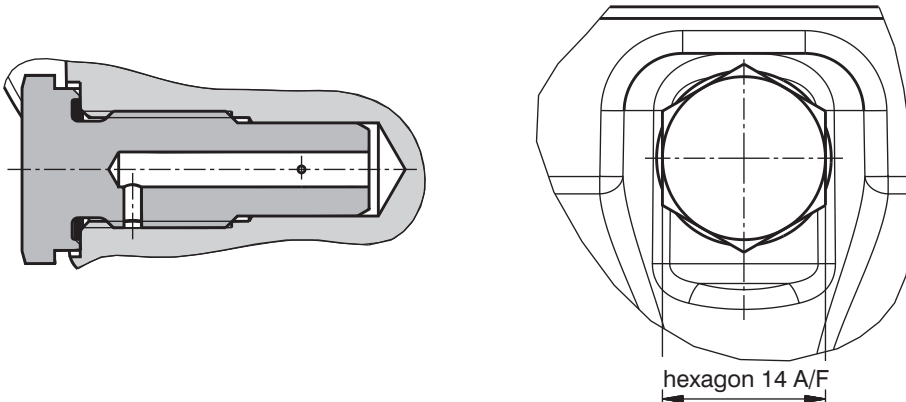

T3 - Throttle Screw

The control orifice allows for stepless adjustment of the valve shifting time.

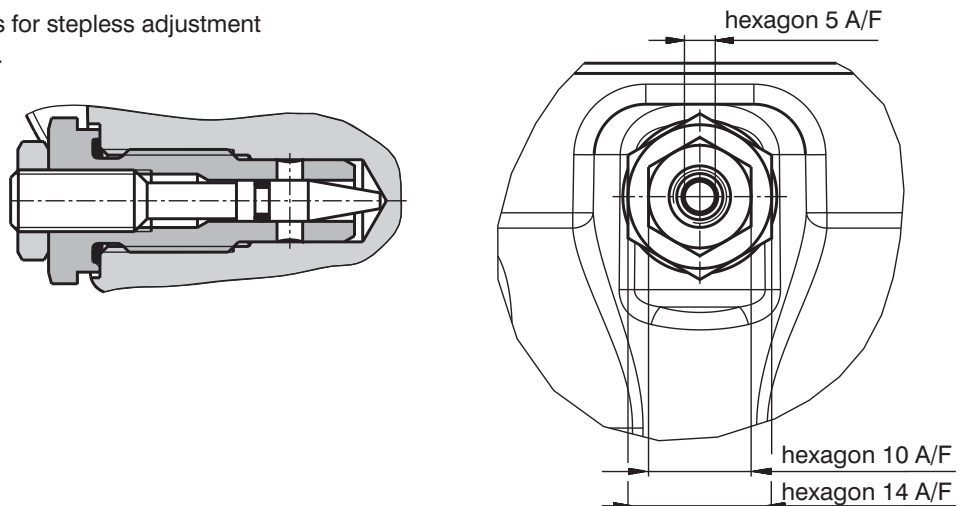

Connector - US - Standard - ANSI/B93.55M

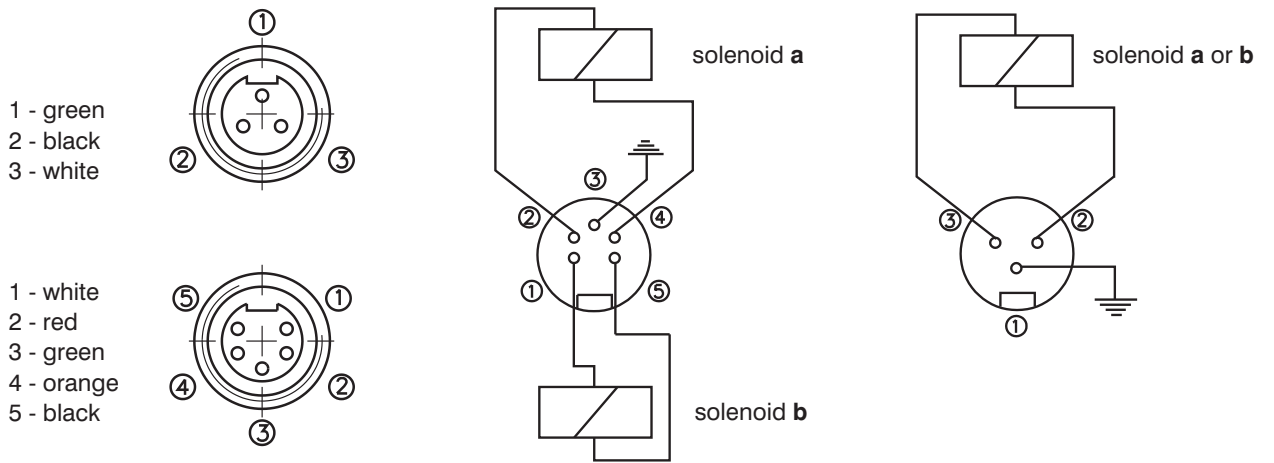

Spare Parts

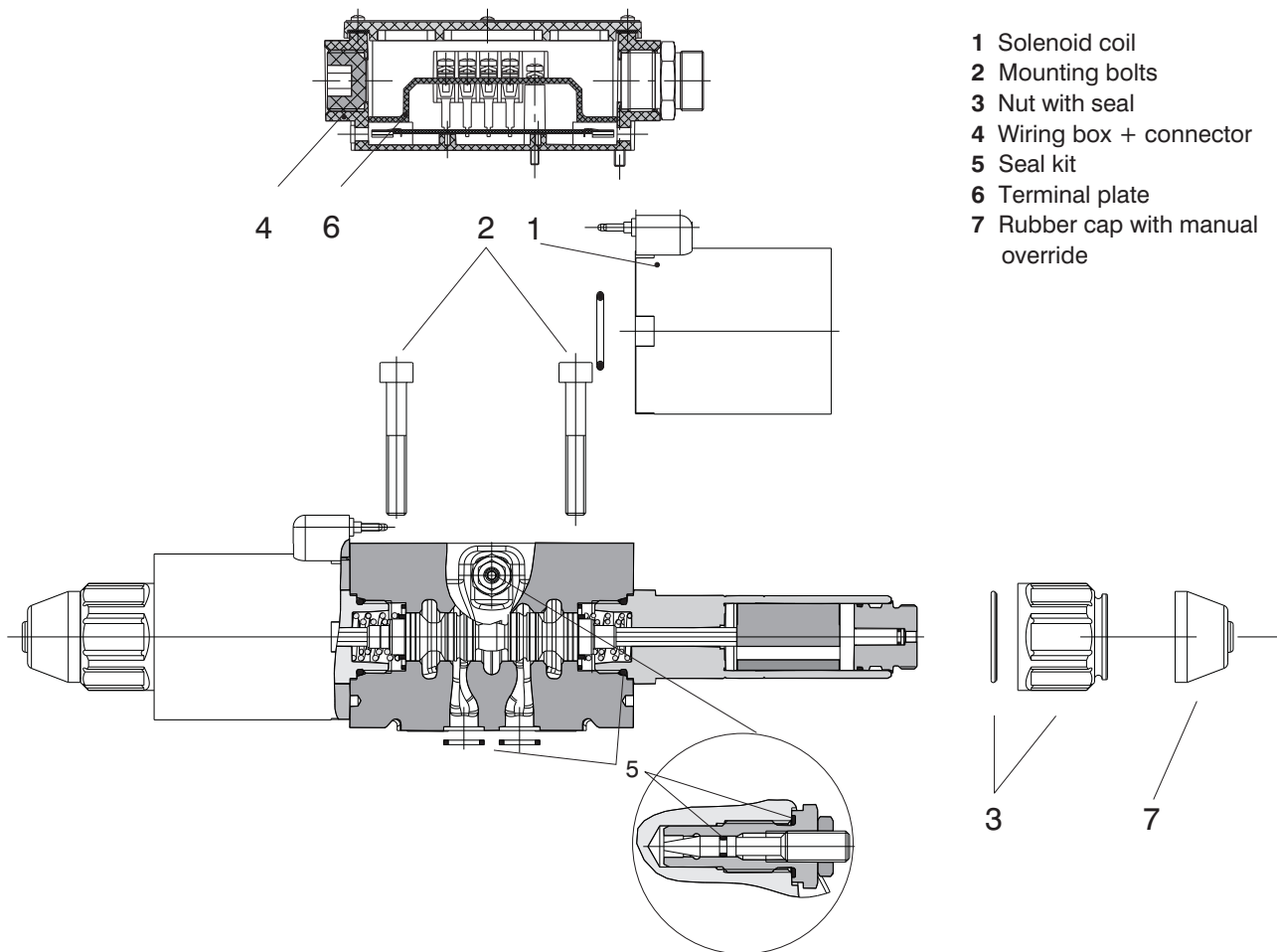

Wiringbox			
Type	Ordering number		
Wiring box without terminal plate	24175100		
Terminal Plates			
Type	Ordering number		
Terminal plate - basic design A+B	24173700		
Terminal plate 12V DC -LED diodes A+B	24173800		
Terminal plate 24V DC - LED diodes A+B	24173900		
*Terminal plate 120V AC - rectifier A+B	24174000		
*Terminal plate 120V AC - rectifier A+B and LED diodes A+B	24174100		
* CSA Upon request 			
Solenoid Coil			
Voltage rating	Type	Ordering number	
01200 DC	EW1	24174200	
02400 DC	EW1	24174300	
10600 DC (120V/60Hz rectified)	EW1	24174400	
Solenoid Retaining Nut with Seal			
Type of the nut	Seal ring	Ordering number	
Standard nut	O-ring 30 x 2	15900800	
Nut with rubber boot		15900900	
Electrical Connector, ANSI/B93.55M			
Type	Ordering number		
3 PIN	24007300		
5 PIN	24007400		
Seal kit			
Type	Dimensions		Ordering number
	Square ring	O-ring	
Standard NBR70	12.42 x 1.68 (5 pcs.), 11,9 x 8,4 x 1 (1 pc.)	23.81 x 2.62 (2 pcs.), 1,8 x 1 (1 pc.)	15901000
Viton	12.42 x 1.68 (5 pcs.), 11,9 x 8,4 x 1 (1 pc.)	23.47 x 2.62 (2 pcs.), 1,8 x 1 (1 pc.)	15901100
Mounting bolts			
Dimensions	Tightening torque	Ordering number	
M6 x 40 DIN 912-10.9 (4 pcs.)	14+2 Nm (10.33+1.48 lbf.ft)	15847700	
Soft Shift Conversion Kit			
T2	10 Nm (7.376 lbf.ft)	15901200	
T3	10 Nm (7.376 lbf.ft)	15901300	
Caution!			
<ul style="list-style-type: none"> In the case of directional control valves with two solenoids, any of the solenoids may be energized, but only after powering off the other. For directional control valves with other spool symbols as those shown in the table, please consult with the manufacturer. Other spool symbols on request. The plastic packaging is recyclable. The protective plate can be returned to manufacturer. Mounting bolts, studs and DIN-connectors must be ordered separately. Certified documentation is available per request. 			
ARGO-HYTOS s.r.o. CZ - 543 15 Vrchlábí Tel.: +420-499-403 111 E-mail: info.cz@argo-hytos.com www.argo-hytos.com			

- Solenoid pilot operated directional valves (RPEH)
- Hydraulic pilot operated directional valves (RPH)
- Small energy input
- Manual overrides optional (only for RPEH)
- Installation dimensions to DIN 24 340 / ISO 4401 / CETOP RP121-H

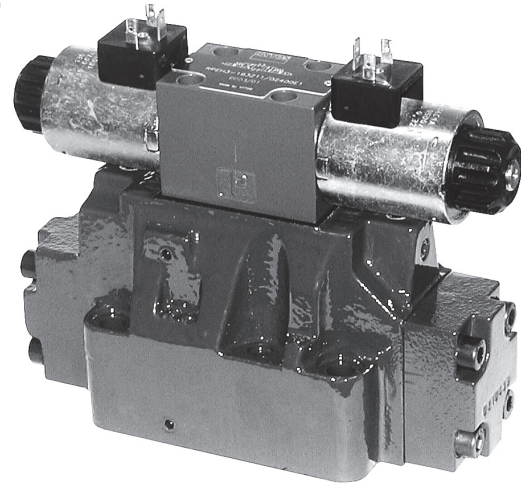
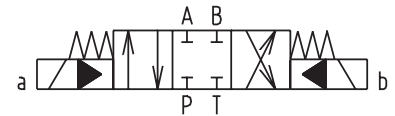

Functional Description

The RPEH solenoid operated - hydropiloted valves are consisting of an RPE3-06 type solenoid operated directional control valve (see data sheet HA 4010) that operates a 4-way hydropiloted control valve with a connection surface in accordance with the ISO 4401 standards. They are available in various configurations and spool types.

The pilot and the drain connections can be made internal or external by inserting or removing the accordant threaded plugs located in the main directional control valve.

A wide range of configurations and different solenoid operated - hydropiloted directional control valve spool positions are available:

- 4-way, 3-position directional control valve, with two solenoids; positioning of the spool in center position is obtained with centering springs.
- 4-way, 2-position directional valve, with one solenoid and one return spring or two solenoids and detent of the spool position.

The basic surface treatment of the valve housing is phosphate coated and the solenoids are zinc coated.

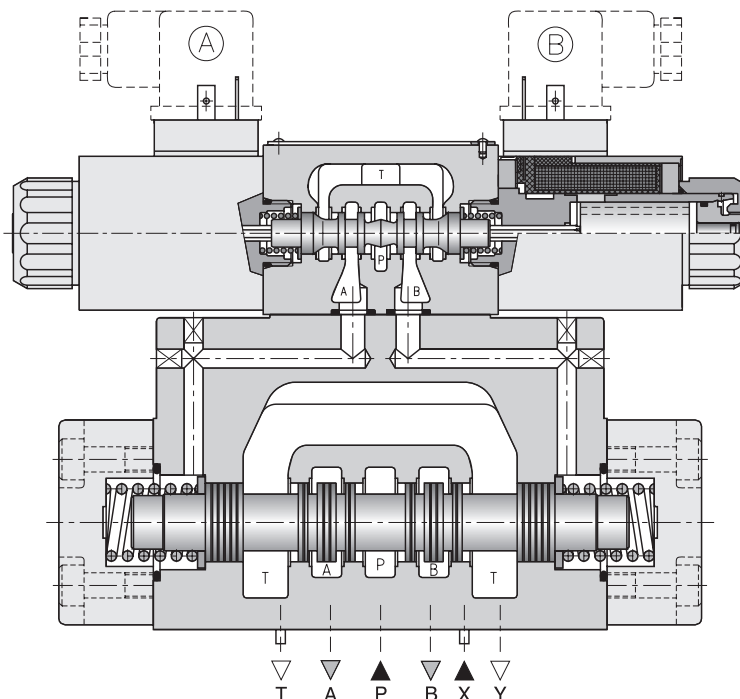

Ordering Code

1

RP [] 4-16 [] [] / [] [] [] / [] /13- [] [] [] / []

Directional Control Valve Pilot Operated

Seals
no designation NBR
V FPM (Viton)

Type of control
electrohydraulically operated **EH**
hydraulically operated **H**

Manual override
no designation standard
N1 covered with retaining nut
N2 covered with rubber boot

Design series

Type of solenoid coil
E1 with terminal for the connector*
E2 with integrated quenching diode and terminal for the connector*
E5 with integrated rectifier and terminal for the connector*
* from EN 1745301-803-A

Valve size

Rated supply voltage of solenoids *
(at the coil terminals)

Number of operating positions
two positions **2**
three positions **3**

01200 12 V DC / 2.72 A
02400 24 V DC / 1.29 A
12060 120 V AC / 0.35 A / 50 (60) Hz
23050 230 V AC / 0.17 A / 50 (60) Hz

The AC coils correspond with E5 type.
* Other voltages per request.

Functional symbols
see the table functional symbols

Series number

Controls
if not required no designation
main spool shifting speed control **D**
shifting speed control, with orifice (0.8 mm) **PF**
in port P of solenoid pilot valve

Check valve incorporated in P-line
no designation if not required
C3 with check valve (see page 7)

Piloting
if not required no designation
external piloting (see note herebelow) **E**

Drain
no designation external drain which is recommended when the valve is used with back pressure on the outlet
I internal drain

Note:
Piloting must always be external for valves with the H11 type pilot valve (available on request). Also valve must have external piloting for spools with P and T connected in the center position. Internal piloting is possible only with a C3 version valve (see page 7), or by installing a check valve with a setting of min. 5 bar on the outlet line. In this case the valve must have external drainage.
Piloting must always be external for valves with the RPH type hydraulic control valve (available on request).

Technical Data

Valve size	mm (US)	16 (D 07)
Maximum flow rate from port P to A, B, T	L/min (GPM)	300 (80)
Max. operating pressure ports P, A, B port T port T (external drain version)	bar (PSI)	320 (4600) 210 (3000) 250 (3600)
Pressure drop	bar (PSI)	see Pressure Drop $\Delta p-Q$
Hydraulic fluid		Hydraulic oils of power classes (HL, HLP) to DIN 51524
Fluid temperature range for NBR seals	°C (°F)	-30 ... +80 (-22 ... +176)
Fluid temperature range for FPM seals	°C (°F)	-20 ... +80 (-4 ... +176)
Ambient temperature max.	°C (°F)	+50 (+122)
Viscosity range	mm ² /s (SUS)	20 ... 400 (98 ... 1840)
Maximum degree of fluid contamination		Class 21/18/15 to ISO 4406
Service life	cycles	10 ⁷
Enclosure type to EN 60529		IP 65
Weight - RPEH4-162 - RPEH4-163	kg (lbs)	8,5 (19) 9,1 (20)

Functional Symbols

Symbols are referred to the solenoid valve RPEH. For the hydraulic control version RPH please verify the connection scheme (see page 7).

Three positions with spring centering		Three positions with spring centering	
Z11			H11
Y11			C11
Two positions with return spring		Two positions with return spring	
R51			X51
R52			X52
Two positions with mechanical detent on pilot valve			
J17			
J27			

Besides the diagrams shown, which are the most frequently used, other special versions are available: consult our technical department for their identification, feasibility and operating limits.

Performance Characteristic

Pressures in bar (PSI)	MIN.	MAX.
Pilot pressure	5 (72.5)	210 (3043)
Pressure on line T with internal drainage	-	140 (2029)
Pressure on line T with external drainage	-	250 (3623)

Maximum flow rates in L/min (GPM)	PRESSURES	
	210 bar (3045 PSI)	320 bar (4640 PSI)
Spool type C11	250 (66)	200 (53)
All other spools	300 (80)	250 (66)

Pressure Drop Δp -Q

Measured at $v = 32 \text{ mm}^2/\text{s}$ (156 SUS) and $t = 40 \text{ }^\circ\text{C}$ (104 $^\circ\text{F}$)

Pressure drop Δp related to flow rate.

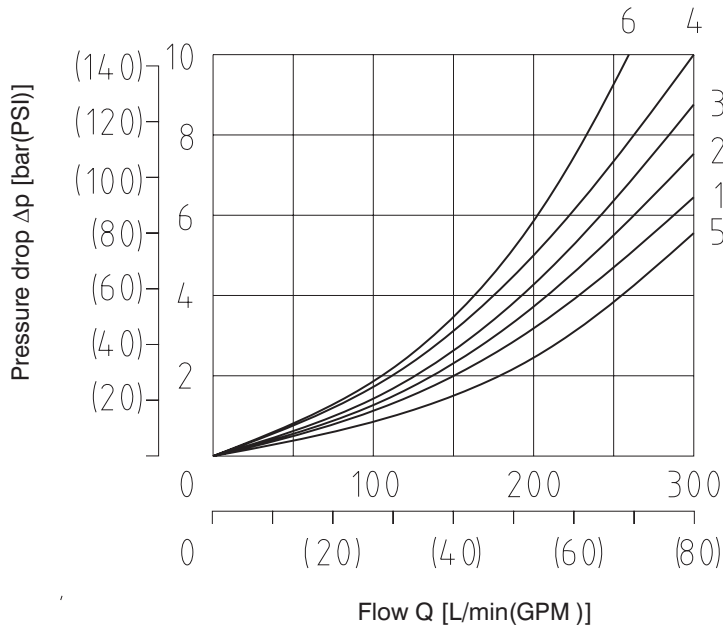

Spool type	Spool position	Connections				
		P - A	P - B	A - T	B - T	P - T
Curves on graph						
Z11	Energized	1	1	2	3	
H11	De-energized					6*
	Energized	5	5	1	2	
Y11	De-energized			4°	4°	
	Energized	1	1	1	2	
C11	De-energized					6
	Energized	6	6	3	4	
R51, R52, X51, X52	De-energized	1			1	
	Energized		1	2		
J17, J27	Energized	1	1	2	3	

* A-B blocked • B blocked ° A blocked

Pilot and Drain

The RPEH4 valves are available with pilot and drain, both internal and external. The version with external drain allows for a higher back pressure on the outlet.

Type of valve		Plug assembly	
		X	Y
RPEH4-16**/*	Internal pilot and external drain	NO	YES
RPEH4-16**/*I	Internal pilot and internal drain	NO	NO
RPEH4-16**/*E	External pilot and external drain	YES	YES
RPEH4-16**/*EI	External pilot and internal drain	YES	NO

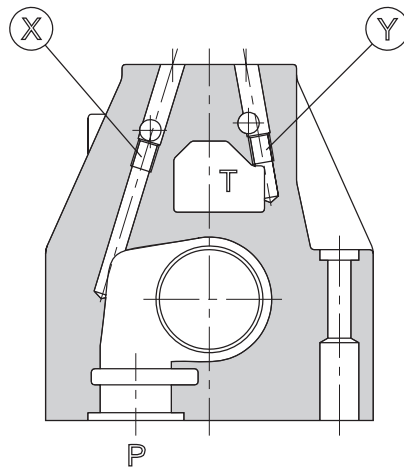

X: plug M6 x 8 for external pilot
Y: plug M6 x 8 for external drain

Electrical Features

Solenoids

The operating solenoids are DC solenoids. For AC supply the solenoids are provided with rectifier which are integrated in the DIN connector socket as part of the solenoid. The connectors can be turned by 90°. By loosening the nut, the solenoids can be turned or replaced without interfering with any seals of the valve. In the case of solenoid malfunction or power failure, the spool of the valve can be shifted by manual override, provided the pressure in T-port does not exceed 25 bar.

		DC solenoid	AC solenoid
Max. allowable voltage variation	%	-10 ... +6	±10
Max. switching frequency	1/h	10 000	
Switching times ±10 %, energizing (two position)	ms	70	60
Switching times ±10 %, de-energizing (two position)	ms	80	80
Switching times ±10 %, energizing (three position)	ms	50	80
Switching times ±10 %, de-energizing (three position)	ms	60	60
Duty cycle	%	100	
Service life	cycles	10 ⁷	
Enclosure type to EN 60 529		IP 65	

The values indicated refer to a solenoid valve operating with piloting pressure 100 bar, viscosity of 32 mm²/s and with PA and BT connections. The switch on times are obtained from the time the spool switches over. The switch off times are measured at the time pressure variation occurs in the line.

Valve Dimensions

Dimensions in millimeters (inches)

RPEH4-162, RPEH4-163

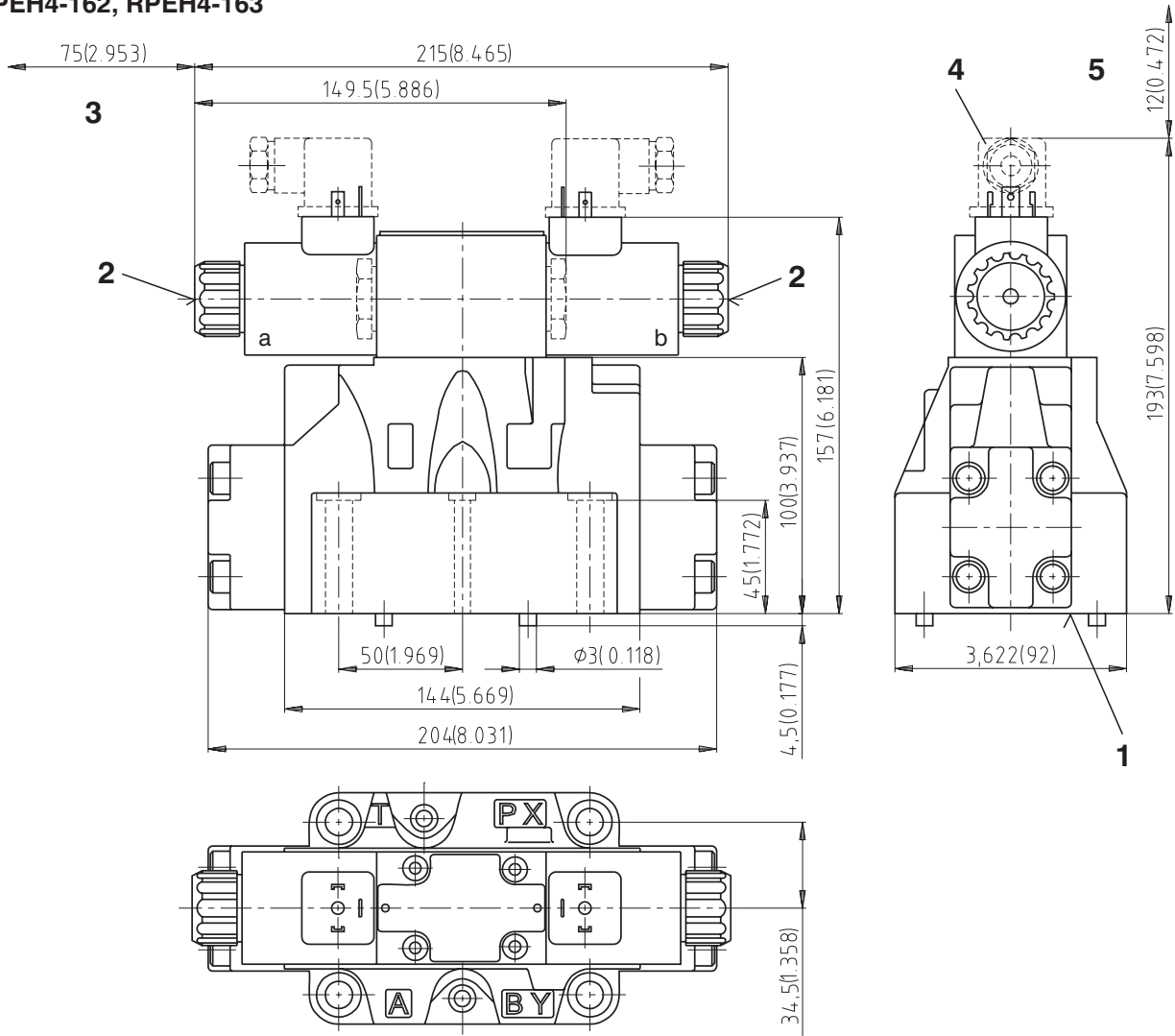

- 1 Mounting surface with seal rings
- 2 Manual override
- 3 Space required to remove coil
- 4 Electrical connector (must be ordered separately)
- 5 Space required to remove connector

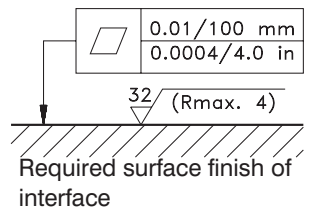
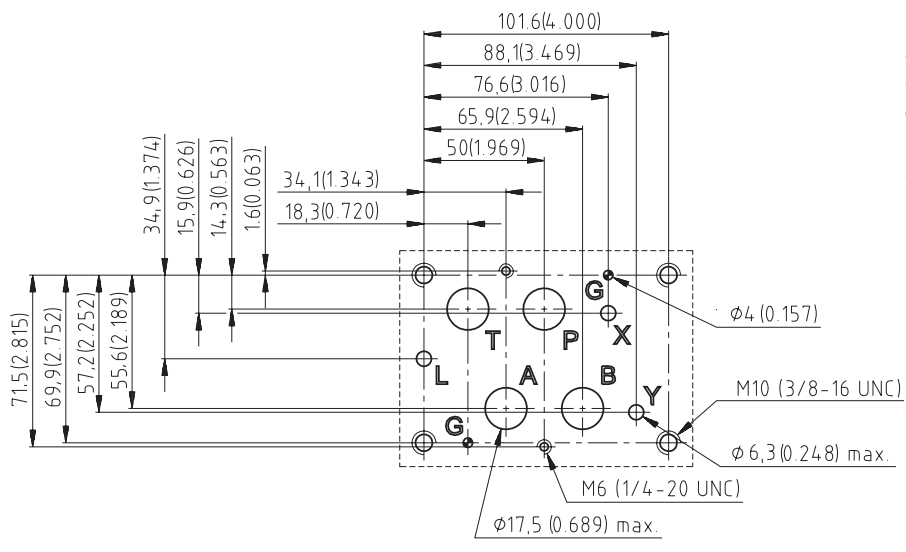

Single valve fastening:	4 bolts M10 x 60 * 2 bolts M6 x 60 *	* Bolts is not supplied
Bolt torque:	M10 x 60: 40 Nm(29.5 ft-lbs) - bolts A 8.8 M6 x 60: 8 Nm(5.9 ft-lbs) - bolts A 8.8	
Threads of mounting holes:	M6 x 18; M10 x 18	
Seal rings:	4 O-rings type 22.22 x 2.62 2 O-rings type 10.82 x 1.78	

Type of Command

Solenoid control: RPEH

The valve is supplied with a pilot solenoid valve type RPE3-06.

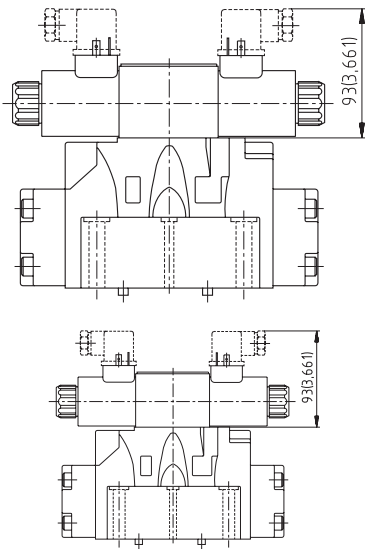

Hydraulic control: RPH

The valve is supplied with a cross-connection cover-plate.

X and Y connections are used for the hydraulic control of the valve.

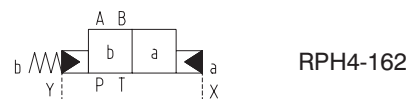
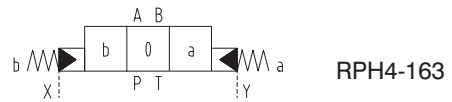

Controls

Control of the main spool shifting speed: D

By placing a 2VS3-06 type double flow control valve between the pilot solenoid valve and the hydropiloted valve, the piloted flow rate can be controlled and therefore the shifting speed can be varied. Add the letter **D** to the identification code to request this device.

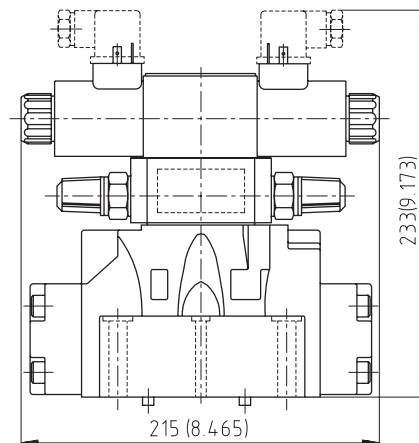

Manual Override

Whenever the solenoid valve installation may involve exposure to atmospheric agents or be used in tropical climates, the manual override, boot protection is recommended. Add the suffix **N1** or **N2** to request this device.

Electrical Connector

The solenoid valves are never supplied with connector. Connectors must be ordered separately.

Special Configurations C3

Check valve incorporated on line P: C3

Valve RPEH is available upon request with check valve incorporated on line P. This is particularly useful to obtain the necessary piloting pressure when the main control valve, in the rest position, has line P connected to the T outlet. The cracking pressure is 5 bar. Add **C3** to the identification code for this request.

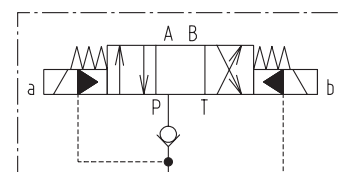

Installation

Configurations with centering and recall springs can be mounted in any position; type J17, J27 valves - without springs and with mechanical retention must be mounted with the longitudinal axis horizontal. Valve fastening takes place by means of screws or tie rods, placing the valve on a flat surface, with values of planarity and smoothness that are equal to or better than those indicated in the drawing. If the minimum values of planarity or smoothness are not met, fluid leakages between valve and mounting surface can easily occur.

Spare Parts

Seal kit

	Design	Dimensions, number			Ordering number	
		O-ring	Square ring	Back-up ring		
Head valve size 16 (D 07)	Standard - NBR	22.22 x 2.62 (4 pcs.)	-	-	21833700	
		10.82 x 1.78 (2 pcs.)				
		31.42 x 2.62 (2 pcs.)				
	Viton	22.22 x 2.62 (4 pcs.)				
		10.82 x 1.78 (2 pcs.)				
		31.42 x 2.62 (2 pcs.)				
Throttle valve 2VS3-06-CS type number 15929600	Standard - NBR	18 x 2.65 (2 pcs.)	9.25 x 1.68 (4 pcs.)	6.73 x 9.43 x 1.14 (2 pcs.)	15936300	
		6.9 x 1.8 (2 pcs.)				17.83 x 22.19 x 1.14 (2 pcs.)
	Viton	17.12 x 2.62 (2 pcs.)			9.43 x 6.73 x 1.14 (2 pcs.)	15936600
		9.25 x 1.78 (4 pcs.)			17.83 x 22.19 x 1.14 (2 pcs.)	
		6.75 x 1.78 (2 pcs.)			-	
		-			-	
Control valve	see data sheet ARGO-HYTOS - HA 4010 - RPE3-06					

Mounting bolt

	Dimensions, number		Tightening torque	Ordering number
Fixation of extension of valve	Bolt M5 x 45	DIN 912-10.9 (4pcs.)	8.9 Nm (6.6 ft-lbs)	15845100
	Bolt M5 x 98 - 8G	(4 pcs.)		16103700
	Nut M5			

Other

	Design	Ordering number
Cover plate	PA, BT	15934200
	PB, TA	15933700

Caution!

- Service valve without range stated parameter consultation with manufacturer.
- Detailed information at control valve - see data sheet RPE3-06, HA 4010
- The packing foil is recyclable.
- The protective plate can be returned to manufacturer.
- The technical information regarding the product presented in this data sheet is for descriptive purposes only. It should not be construed in any case as a guaranteed representation of the product properties in the sense of the law.

ARGO-HYTOS s.r.o. CZ - 543 15 Vrchlaví
Tel.: +420-499-403111, Fax: +420-499-403421
E-mail: sales.cz@argo-hytos.com
www.argo-hytos.com

- Solenoid pilot operated directional valves (RPEH)
- Hydraulic pilot operated directional valves (RPH)
- Small energy input
- Manual overrides optional (only for RPEH)
- Installation dimensions to DIN 24 340 / ISO 4401 / CETOP RP121-H

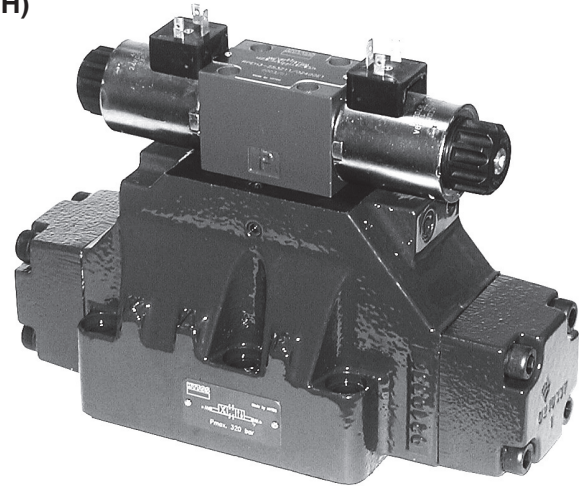
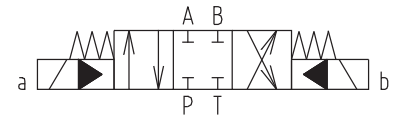

Functional Description

The RPEH solenoid operated - hydropiloted valves are consisting of an RPE3-06 type solenoid operated directional control valve (see data sheet HA 4010) that operates a 4-way hydropiloted control valve with a connection surface in accordance with the ISO 4401 standards. They are available in various configurations and spool types.

The pilot and the drain connections can be made internal or external by inserting or removing the accordant threaded plugs located in the main directional control valve.

A wide range of configurations and different solenoid operated - hydropiloted directional control valve spool positions are available:

- 4-way, 3-position directional control valve, with two solenoids; positioning of the spool in center position is obtained with centering springs.
- 4-way, 2-position directional valve, with one solenoid and one return spring or two solenoids and detent of the spool position.

The basic surface treatment of the valve housing is phosphate coated and the solenoids are zinc coated.

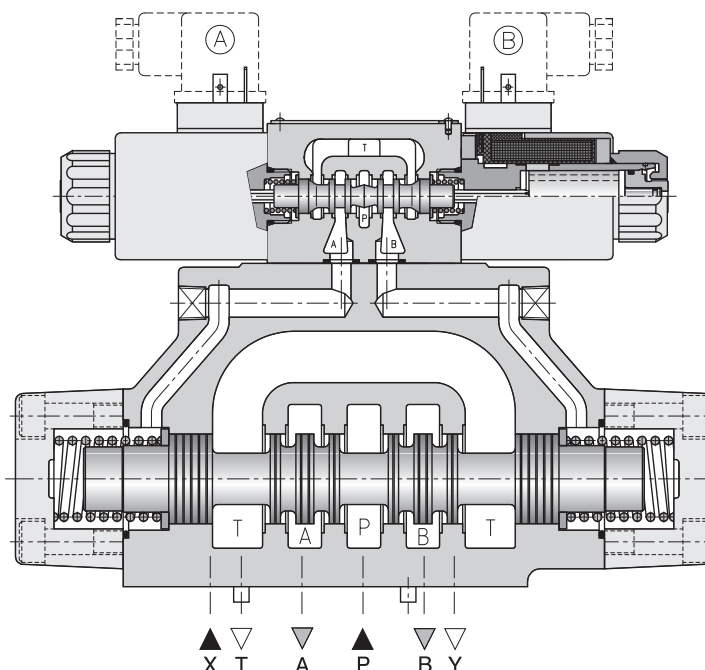

Ordering Code

1

RP [] 4-25 [] [] / [] [] [] / [] /33- [] [] [] / []

Directional Control Valve Pilot Operated

Seals
no designation NBR
V FPM (Viton)

Type of control
electrohydraulically operated **EH**
hydraulically operated **H**

Manual override
no designation standard
N1 covered with retaining nut
N2 covered with rubber boot

Design series

Type of solenoid coil
E1 with terminal for the connector*
E2 with integrated quenching diode and terminal for the connector*
E5 with integrated rectifier and terminal for the connector*
* from EN 1745301-803

Valve size 25 (D 08)

Rated supply voltage of solenoids *
(at the coil terminals)

Number of operating positions
two positions **2**
three positions **3**

01200 12 V DC / 2.72 A
02400 24 V DC / 1.29 A
12060 120 V AC / 0.35 A / 50 (60) Hz
23050 230 V AC / 0.17 A / 50 (60) Hz

Functional symbols
see the table Functional Symbols

The AC coils correspond with E5 type.
* Other voltages per request.

Series number

Controls
if not required no designation
main spool shifting speed control **D**
shifting speed control, with orifice (0.8 mm) **PF**
in port P of solenoid pilot valve

Check valve incorporated on P-line
no designation if not required
C3 with check valve (see pages 5, 7)

Piloting
if not required no designation
external piloting (see note herebelow) **E**

Drain
no designation external drain which is recommended when the valve is used with back pressure on the outlet
I internal drain

Note:
Piloting must always be external for valves with the H11 type pilot valve (available on request). Also valve must have external piloting for spools with P and T connected in the center position. Internal piloting is possible only with a C3 version valve (see page 7), or by installing a check valve with a setting of min. 5 bar on the outlet line. In this case the valve must have external drainage.
Piloting must always be external for valves with the RPH type hydraulic control valve (available on request).

Technical Data

Valve size	mm (US)	25 (D 08)
Maximum flow rate from port P to A, B, T	L/min (GPM)	600 (159)
Max. operating pressure ports P, A, B port T port T (external drain version)	bar (PSI)	320 (4600) 210 (3000) 250 (3600)
Pressure drop	bar (PSI)	see Pressure Drop $\Delta p-Q$
Hydraulic fluid		Hydraulic oils of power classes (HL, HLP) to DIN 51 524
Fluid temperature range for NBR seals	°C (°F)	-30 ... +80 (-22 ... +176)
Fluid temperature range for FPM seals	°C (°F)	-20 ... +80 (-4 ... +176)
Ambient temperature max.	°C (°F)	+50 (+122)
Viscosity range	mm ² /s (SUS)	20 ... 400 (98 ... 1840)
Maximum degree of fluid contamination		Class 21/18/15 to ISO 4406
Service life	cycles	10 ⁷
Enclosure type to EN 60 529		IP 65
Weight - RPEH4-252 - RPEH4-253	kg (lbs)	15 (33) 15.6 (34.3)

Functional Symbols

Symbols are referred to the solenoid valve RPEH. For the hydraulic control version RPH please verify the connection scheme (see page 7).

Three positions with spring centering		Three positions with spring centering	
Z11			H11
Y11			C11
Two positions with return spring		Two positions with return spring	
R51			X51
R52			X52
Two positions with mechanical detent on pilot valve			
J17			
J27			

Besides the diagrams shown, which are the most frequently used, other special versions are available: consult our technical department for their identification, feasibility and operating limits.

Performance Characteristic

Pressures in bar (PSI)	MIN.	MAX.
Pilot pressure	5 (72.5)	210 (3045)
Pressure on line T with internal drain	-	140 (2030)
Pressure on line T with external drain	-	250 (3625)

Maximum flow rates in L/min (GPM)	PRESSURES	
	210 bar (3045 PSI)	320 bar (4640 PSI)
Spool type C11	500 (133)	450 (119)
All other spools	600 (159)	500 (133)

Pressure Drop Δp -Q

Measured at $v = 32 \text{ mm}^2/\text{s}$ (156 SUS) and $t = 40 \text{ }^\circ\text{C}$ (104 $^\circ\text{F}$)

Pressure drop Δp related to flow rate.

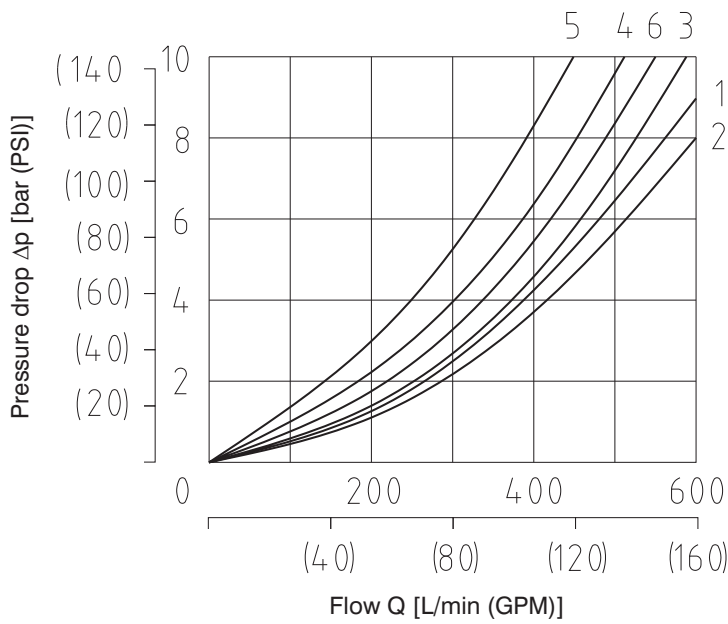

Spool type	Spool position	Connections				
		P - A	P - B	A - T	B - T	P - T
Curves on graph						
Z11	Energized	1	1	2	3	
H11	De-energized					6*
	Energized	5	5	1	2	
Y11	De-energized			4°	4°	
	Energized	1	1	1	2	
C11	De-energized					6
	Energized	6	6	3	4	
R51, R52, X51, X52	De-energized	1			1	
	Energized		1	2		
J17, J27	Energized	1	1	2	3	

* A-B blocked • B blocked ° A blocked

Pilot and Drain

The RPEH4 valves are available with pilot and drain, both internal and external. The version with external drain allows for a higher back pressure on the outlet.

Type of valve		Plug assembly	
		X	Y
RPEH4-25**/*	Internal pilot and external drain	NO*	YES
RPEH4-25**/*I	Internal pilot and internal drain	NO*	NO
RPEH4-25**/*E	External pilot and external drain	YES	YES
RPEH4-25**/*EI	External pilot and internal drain	YES	NO

* C3 version is available only with internal pilot.

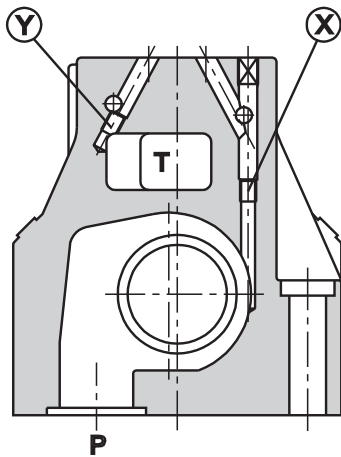

X: plug M6 x 8 for external pilot
Y: plug M6 x 8 for external drain

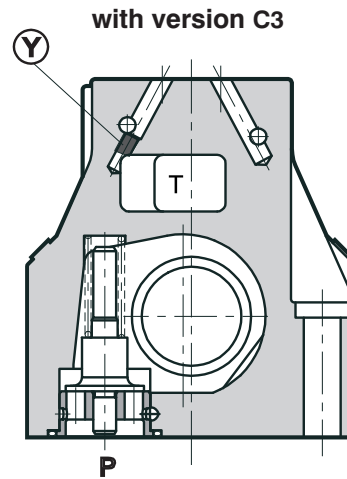

Y: plug M6 x 8 for external drain

Electrical Features

Solenoids

The operating solenoids are DC solenoids. For AC supply the solenoids are provided with rectifier which are integrated in the EN connector socket as part of the solenoid. The connectors can be turned by 90°. By loosening the nut, the solenoids can be turned or replaced without interfering with any seals of the valve.

In the case of solenoid malfunction or power failure, the spool of the valve can be shifted by manual override, provided the pressure in T-port does not exceed 25 bar.

		DC solenoid	AC solenoid
Max. allowable voltage variation	%	-10 ... +6	±10
Max. switching frequency	1/h	8 000	
Switching times ±10 %, energizing (two position)	ms	75	60
Switching times ±10 %, de-energizing (two position)	ms	90	90
Switching times ±10 %, energizing (three position)	ms	55	45
Switching times ±10 %, de-energizing (three position)	ms	60	60
Duty cycle	%	100	
Service life	cycles	10 ⁷	
Enclosure type to EN 60 529		IP 65	

The values indicated refer to a solenoid valve operating with piloting pressure 100 bar, with mineral oil at a temperature of 40 °C, a viscosity of 32 mm²/s and with PA and BT connections. The switch on times are obtained from the time the spool switches over. The switch off times are measured at the time pressure variation occurs in the line.

Valve Dimensions

Dimensions in millimetres (inches)

RPEH4-252, RPEH4-253

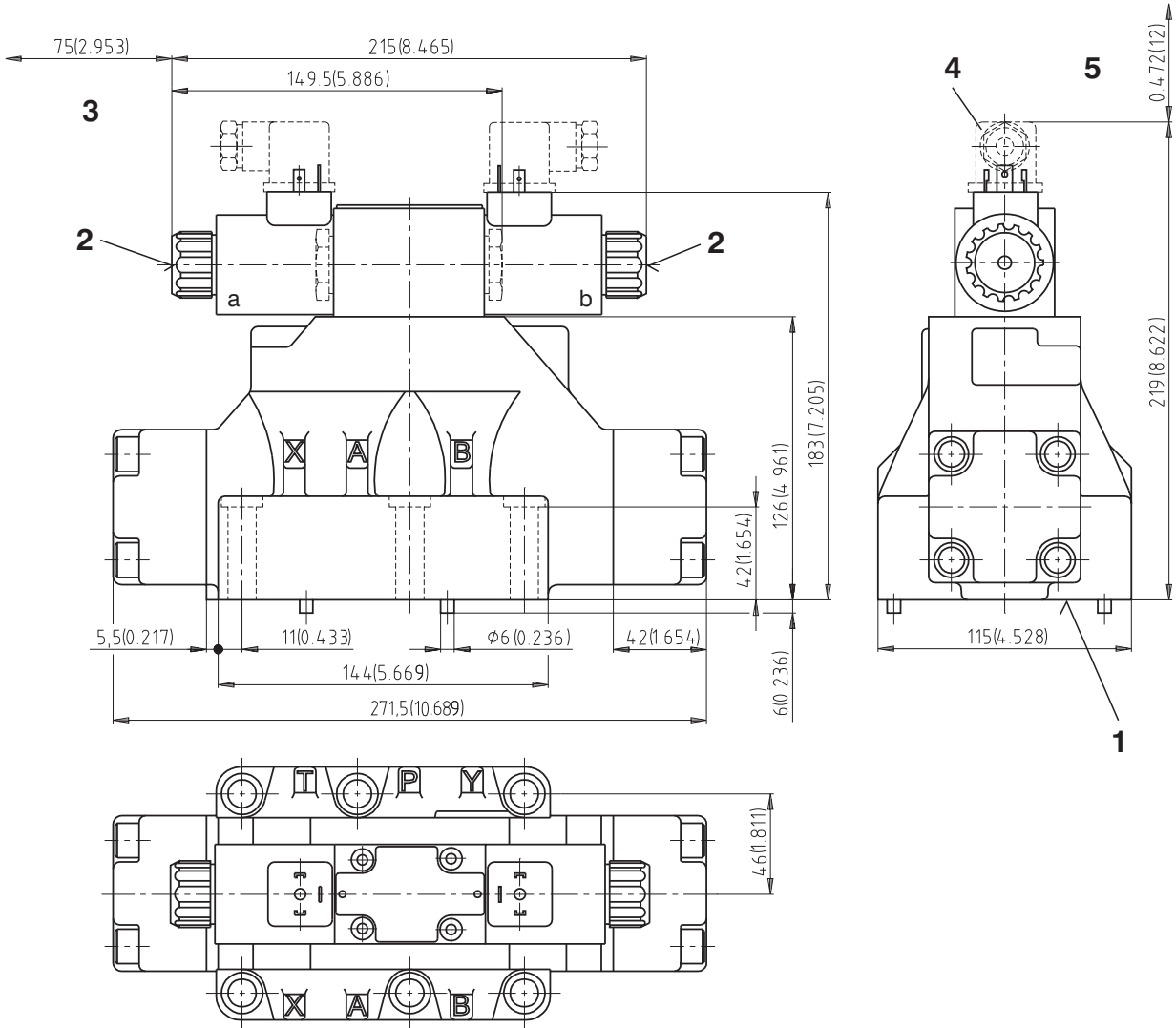

Installation dimensions

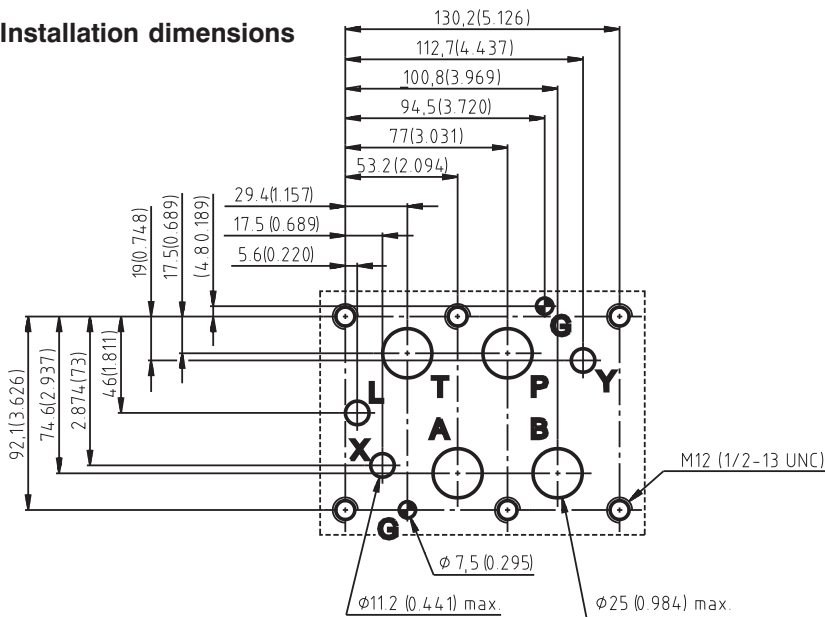

- 1 Mounting surface with seal rings
- 2 Manual override
- 3 Space required to remove coil
- 4 Electrical connector
(must be ordered separately)
- 5 Space required to remove connector

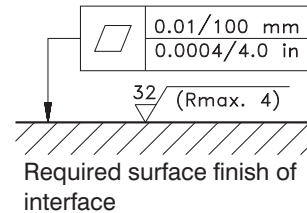

Single valve fastening:	6 bolts M12 x 60 *	* Bolts is not supplied
Bolt torque:	69 Nm (50.9 ft-lbf) - bolts A 8.8	
Threads of mounting holes:	M12 x 20 (1/2-13 UNC)	
Seal rings:	4 O-rings 29,82 x 2,62 2 O-rings 20,29 x 2,62	

Type of Command

Solenoid control: RPEH

The valve is supplied with a pilot solenoid valve type RPE3-06.

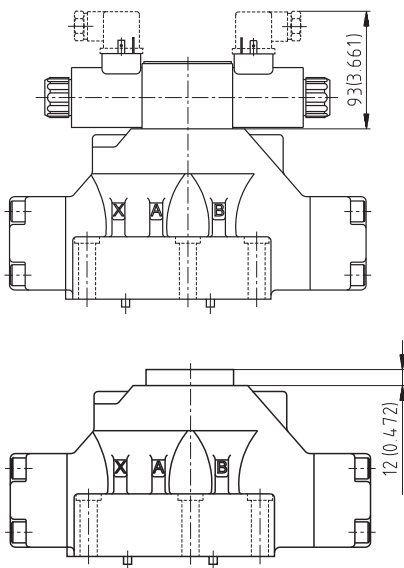

Hydraulic control: RPH

The valve is supplied with a cross-connection cover-plate. X and Y connections are used for the hydraulic control of the valve.

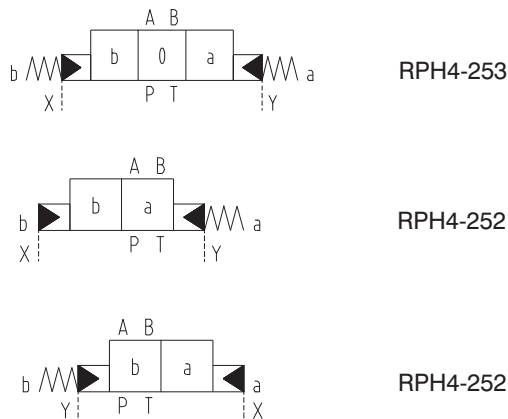

Controls

Control of the main spool shifting speed: D

By placing a 2VS3-06 type double flow control valve between the pilot solenoid valve and the hydropiloted valve, the piloted flow rate can be controlled and therefore the shifting speed can be varied. Add the letter **D** to the identification code to request this device.

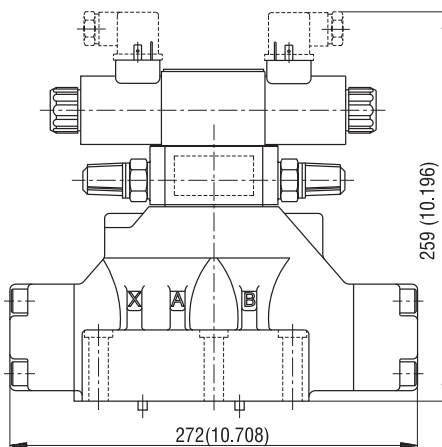

Manual Override

Whenever the solenoid valve installation may involve exposure to atmospheric agents or be used in tropical climates, the manual override, boot protection is recommended. Add the suffix **N1** or **N2** to request this device.

Electrical Connector

The solenoid valves are never supplied with connector. Connectors must be ordered separately.

Special Configurations C3

Check valve incorporated on line P: C3

Valve RPEH is available upon request with check valve incorporated on line P. This is particularly useful to obtain the necessary piloting pressure when the main control valve, in the rest position, has line P connected to the T outlet. The cracking pressure is 5 bar. Add **C3** to the identification code for this request.

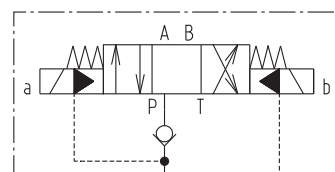

C3 version is available only with internal pilot.

Installation

Configurations with centering and recall springs can be mounted in any position; type J17, J27 valves - without springs and with mechanical retention must be mounted with the longitudinal axis horizontal. Valve fastening takes place by means of screws or tie rods, placing the valve on a flat surface, with values of planarity and smoothness that are equal to or better than those indicated in the drawing. If the minimum values of planarity or smoothness are not met, fluid leakages between valve and mounting surface can easily occur.

Spare Parts

Seal kit

	Design	Dimensions, number			Ordering number	
		O-ring	Square ring	Back-up ring		
Head valve size 25 (D 08)	Standard - NBR	29,82 x 2,62 (4 pcs.)	-	-	21850300	
		20,29 x 2,62 (2 pcs.)				
		40,94 x 2,62 (2 pcs.)				
		34,59 x 2,62* (1 pc.)				
	Viton	29,82 x 2,62 (4 pcs.)				
		20,29 x 2,62 (2 pcs.)				
		40,94 x 2,62 (2 pcs.)				
		34,59 x 2,62* (1 pc.)				
Throttle valve 2VS3-06-CS type number 15929600	Standard - NBR	18 x 2,65 (2 pcs.)	9,25 x 1,68 (4 pcs.)	6,73 x 9,43 x 1,14 (2 pcs.)	15936300	
		6,9 x 1,8 (2 pcs.)				17,83 x 22,19 x 1,14 (2 pcs.)
	Viton	17,12 x 2,62 (2 pcs.)	-	-	9,43 x 6,73 x 1,14 (2 pcs.)	15936600
		9,25 x 1,78 (4 pcs.)			17,83 x 22,19 x 1,14 (2 pcs.)	
		6,75 x 1,78 (2 pcs.)			-	
		-			-	
Control valve	see data sheet ARGO-HYTOS - RPE3-06					

Mounting bolt

	Dimensions, number		Tightening torque	Ordering number
Fixation of extension of valve	Bolt M5 x 45	DIN 912-10.9 (4 pcs.)	8.9 Nm (6.6 ft-lbf)	15845100
	Bolt M5 x 98 - 8G	(4 pcs.)		16103700
	Nut M5			

Other

	Design	Ordering number
Cover plate	PA, BT	15934200
	PB, TA	15933700

Caution!

- Service valve without range stated parameter consultation with manufacturer.
- Detailed information at control valve - see data sheet RPE3-06, HA 4010
- The packing foil is recyclable.
- The protective plate can be returned to manufacturer.
- The technical information regarding the product presented in this data sheet is for descriptive purposes only. It should not be construed in any case as a guaranteed representation of the product properties in the sense of the law.

ARGO-HYTOS s.r.o. CZ - 543 15 Vrchlábí
tel.: +420-499-403 111
e-mail: info.cz@argo-hytos.com
www.argo-hytos.com

- 3/2 way valves construction
- Reducing valves suitable for mobile applications
- Compact design
- Economical Slip-In
- Two cavities sizes

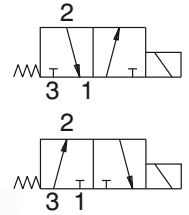

Functional Description

This directly-controlled electromagnetic distributor, in the 3/2 arrangement, is used mostly for opening, blocking and direction controlling of the flow of liquids. The distributor consists of the housing (1), control gate valve (2), counter-spring (3) and magnet coil (4). The electromagnet coil is pressed on (and thus fixed to) the valve control system. The direct current electromagnet coils are supplied for 12 V and 24 V voltage levels.

Once the fixing screw is released, it is possible to turn the distributor around its axis by 360° and change thus the connector socket position (6). The fixing screw (5) and fork (fastening member) (7) form also a part of the supply. In basic variant a part of the valve is exhibited to influence of the environmental atmosphere and the coil zinc plated.

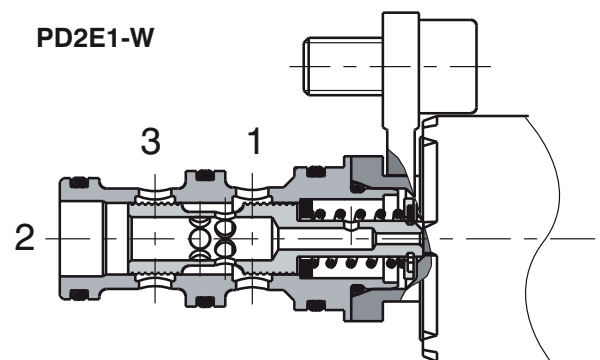
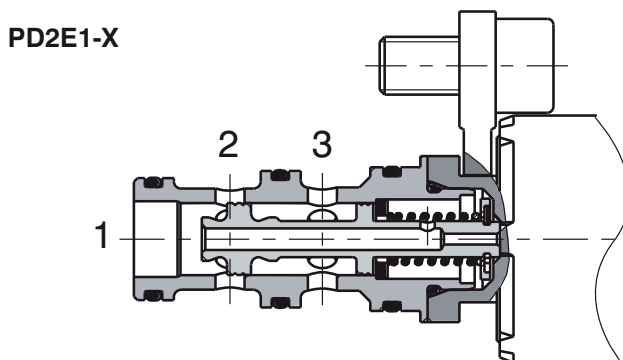
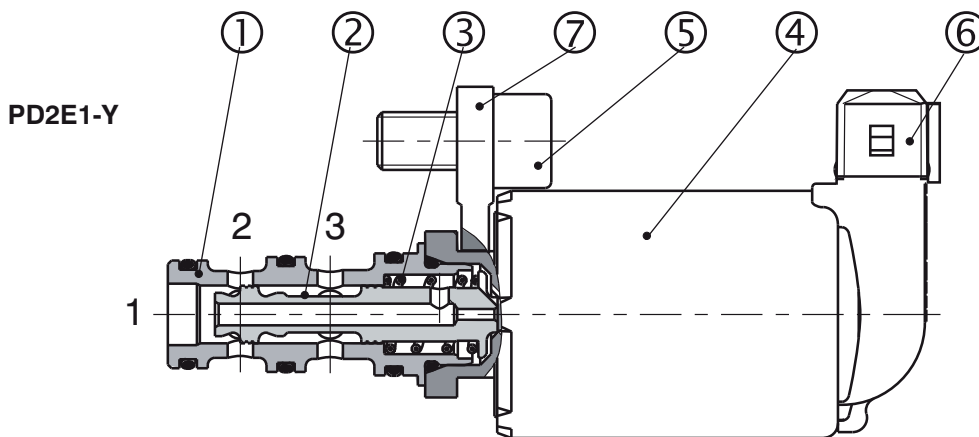

Ordering Code

PD2E - / -

3/2 Way cartridge Directional Valve Solenoid Operated Slip-In

Type of construction 1

Valve cavity
 D17 (mm) (0.669 in) **Y**
 D20 (mm) (0.787 in) **W**
 D20 (mm) (0.787 in) **X**

Number of connections 3

Number of operating positions 2

no designation
V

Seals
 NBR
 FPM (Viton)

Electronics
E3 with AMP-Junior-Timer-connector
E4 with integrated quenching diode and terminal for AMP-Junior-Timer
E12A connector with DEUTSCH DT 04-2P
E13A with integrated quenching diode and terminal for DEUTSCH DT 04-2P

Nominal supply voltage
 12 V DC / 1,67 A
 24 V DC / 0,84 A

Functional Symbols
D21
D26

Functional Symbols

Designation	Symbol	Interposition	Designation	Symbol	Interposition
2D21			2D26		

Technical Data

		Standard	
		D17	D20
Mounting mode			
Maximum flow	L/min (GPM)	30 (7.93)	
Max.operating pressure in Canals Y, X -2, 3, W-3	bar (PSI)	80 (1160)	
Max.operating pressure in Canals Y, X -1, W-2	bar (PSI)	30 (435)	
Pressure drop	bar (PSI)	see Δp-Q characteristic	
Hydraulic fluid		Hydraulic oils of power classes (HL, HLP) to DIN 51524	
Fluid temperature range	°C (°F)	-30 ...90 (-22 ...194), +100 °C (212 °F for a short term)	
Ambient temperature, max.	°C (°F)	-30 ...90 (-22 ...194), +100 °C (212 °F for a short term)	
Viscosity range	mm ² /s (SUS)	10 ... 500 (49 ... 2450)	
Supply voltage	V	12 DC	24DC
Quenching (E4, E13A)		BZW06-19B	BZW06-33B
Maximum degree of fluid contamination		Class 21/18/15 according to ISO 4406	
Supply voltage	%	± 10	
Quenching (E4, E13A)	hod ⁻¹	15 000	
Duty cycle	%	100	
Enclosure type to EN 60529		IP 67	
Service life		10 ⁷	
Weight Directional Control Valves	kg (lbs)	0.2 (0.44)	
Maximum fixing bolt tightening torque	Nm (lbf.ft)	9+2 (6.64+1.48)	
Mounting position		unrestricted	

p-Q Characteristics

Measured at $v = 32 \text{ mm}^2/\text{s}$ (156 SUS)

Oil 90 °C / Ambient temperature 90 °C, Voltage rating $U_n \pm 10\%$

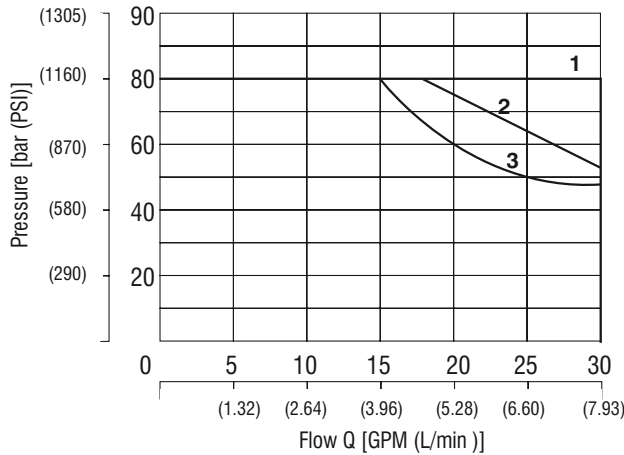

Y3	Connection	Dirrection
1	2D21	2→1
1		3→2
1	2D26	3→2
1		2→1
X3	Connection	Dirrection
1	2D21	2→1
2		3→2
W3	Connection	Dirrection
3	2D21	2→1
1		3→2

Δp-Q Characteristics

Measured at $v = 32 \text{ mm}^2/\text{s}$ (156 SUS)

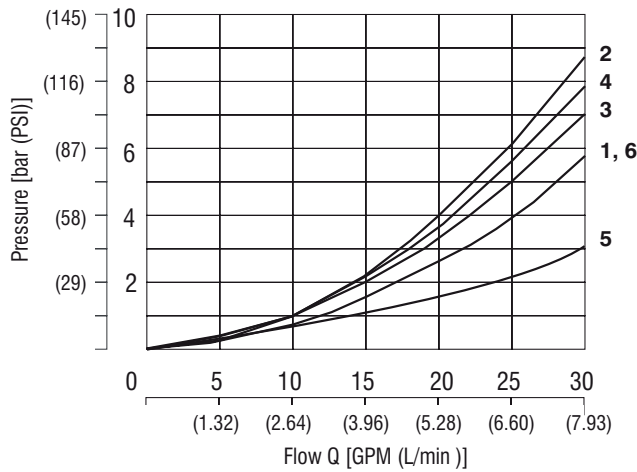

Y3	Connection	Dirrection
1	2D21	2→1
2		3→2
4	2D26	2→1
2		3→2
X3	Connection	Dirrection
4	2D21	3→2
5		2→1
W3	Connection	Dirrection
1	2D21	2→1
6		3→2

Valve body

Dimensions in mm (inches)

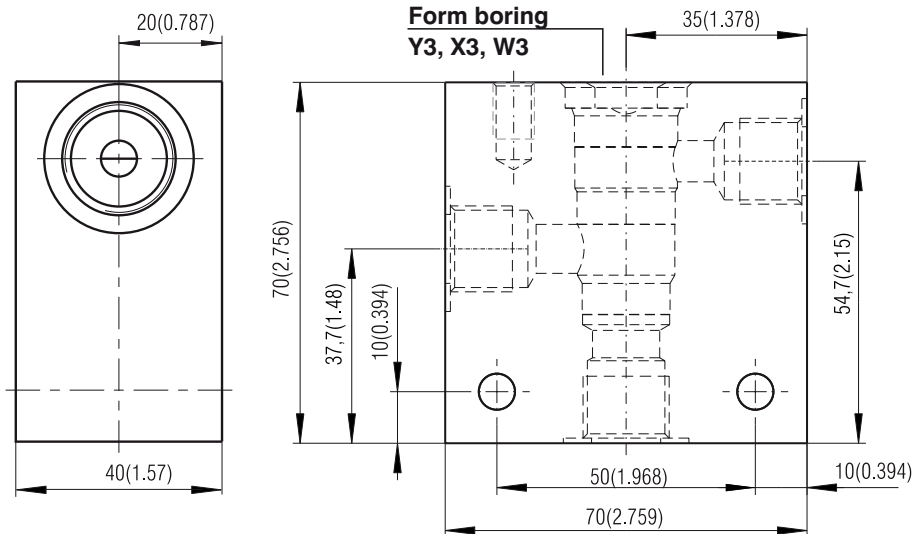

Design	Connecting size	Type code	Body material	Operating pressures
Y	G3/8	SB-Y3-0103AL	Aluminium	250 bar (3625 PSI)
W, X	G3/8	SB-W3-0103AL	Aluminium	250 bar (3625 PSI)

Valve dimensions

Dimensions in mm (inches)

1

PD2E1- Y

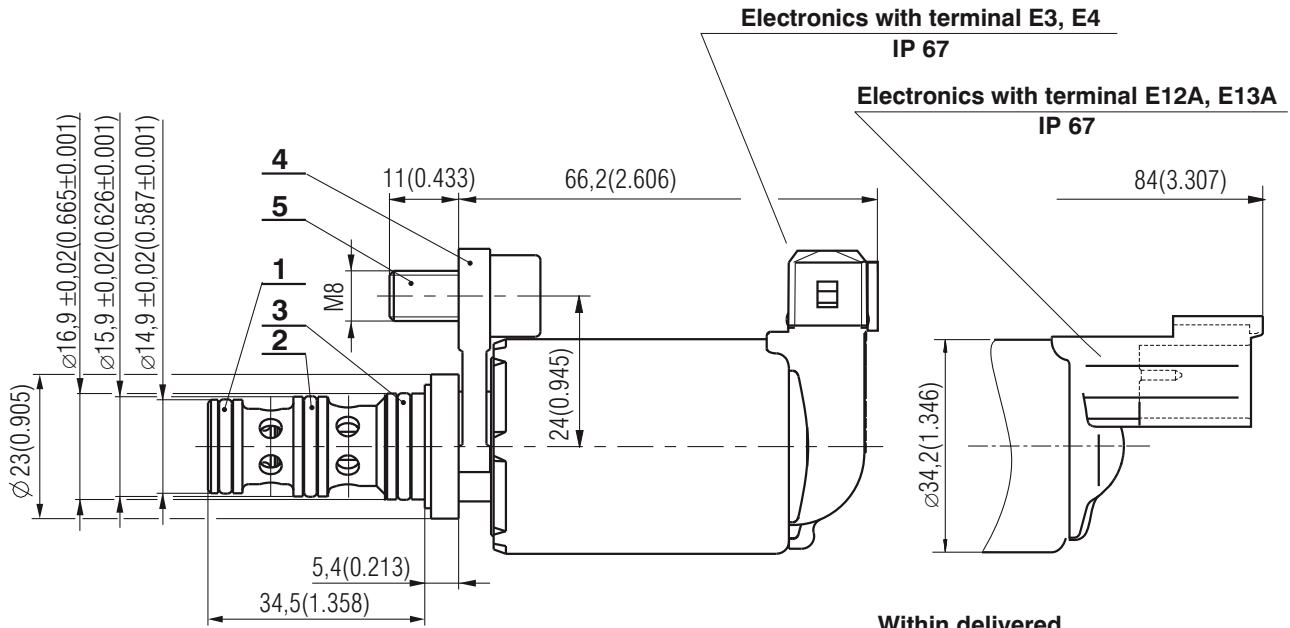

Within delivered

- 1 O-ring 11,2x1,8 NBR 70 (1pc.)
- 2 O-ring 12,42x1,78 NBR 70 (1pc.)
- 3 O-ring 14x1,78-NBR 70 (1 pc.)
- 4 Fork Slip-In M8
- 5 Bolt M8x16 ČSN 021143

PD2E1- X, W

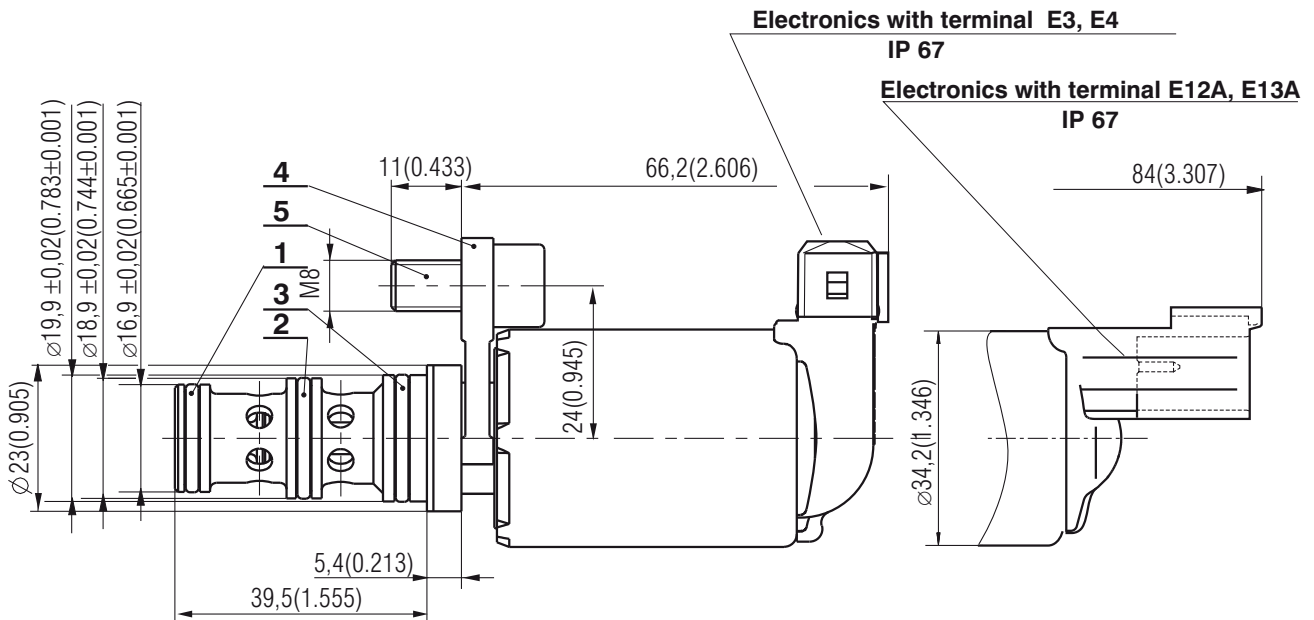

Within delivered

- 1 O-ring 14x1,78 NBR 70 (1pc.)
- 2 O-ring 16x1,8 NBR 70 (1pc.)
- 3 O-ring 17x1,8 NBR 70 (1 pc.)
- 4 Fork Slip-In M8
- 5 Bolt M8x16 ČSN 021143

Cavity

Dimensions in mm

Y - Ø D17

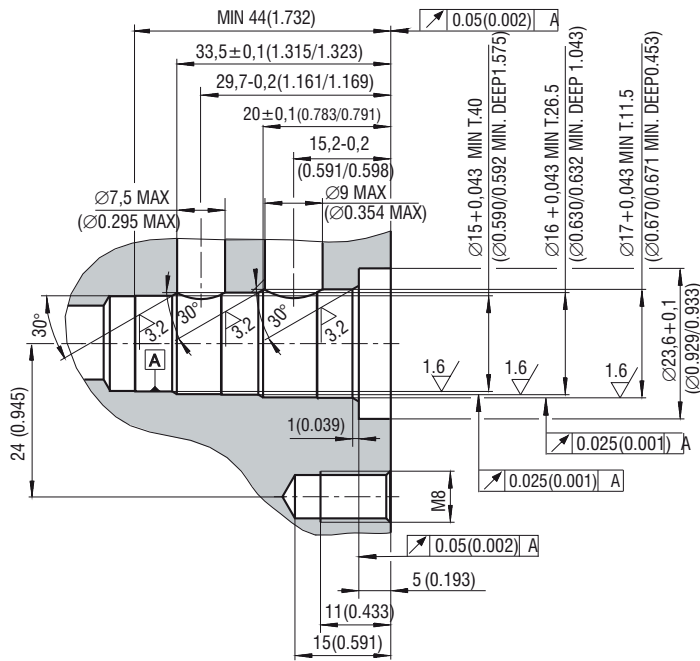

M1:2

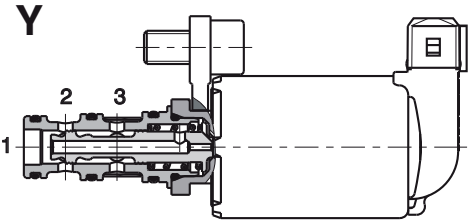

X, W - Ø D20

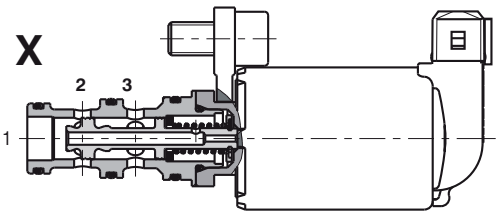
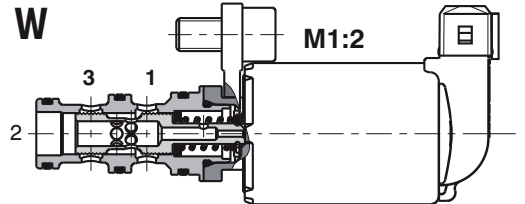
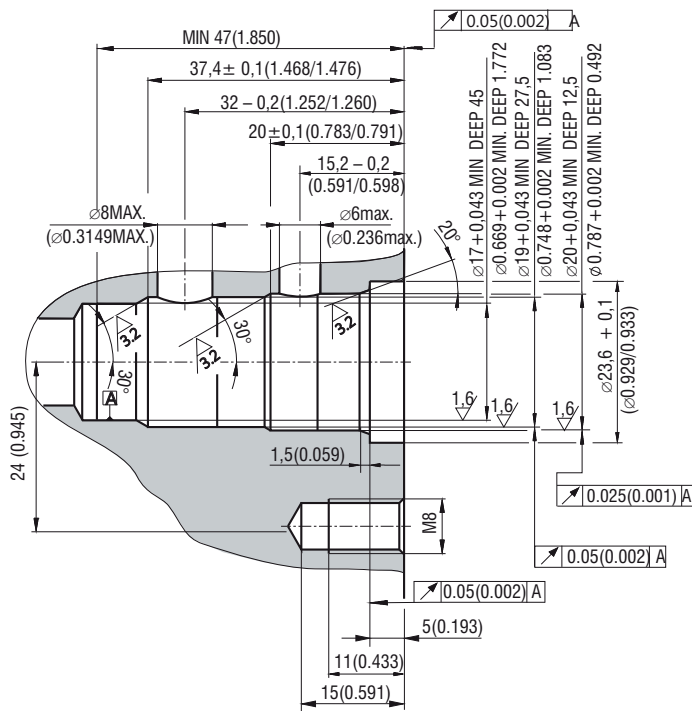

Spare parts

1

Seal set

Design -Standard (NBR70)	Size, number			Ordering number
Y	11,2x1,8 (1pc.)	12,42x1,78 (1pc.)	14x1,78 (1pc.)	17938600
X, W	14x1,78 (1pc.)	16x1,8 (1pc.)	17x1,8 (1pc.)	16961300
Fork+Bolt M8	Fork SLIP-IN M8 (1pc.)	Bolt M8x16 021143 Zn	PO-A (1pc.)	16961500

Caution!

- The plastic packaging is recyclable.
- Certified documentation is available per request.

ARGO-HYTOS s.r.o. CZ - 543 15 Vrchlabí
 Tel.: +420-499-403 111
 E-mail: info.cz@argo-hytos.com
 www.argo-hytos.com

- Hardened precision working parts
- High flow capacity
- High transmitted hydraulic power
- Wide range of manual overrides available
- All ports may be fully pressurized
- Variety of optional spools connections available

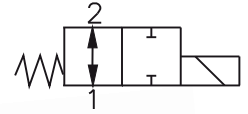

Functional Description

The directly operated 2/2 way solenoid actuated spool valve controls in the first line the start and stop function of the oil flow. The valve consists of the valve body (1), control spool (2), return spring (3), cartridge with actuating system (4) and of the solenoid coil (7).

The valve bushing is fixed in the cartridge by a wire ring (5) and sealed with the seal ring (6). Separation of the valve bushing and the cartridge prevent transmitting the stresses, which could be caused by too high tightening torques. The DC solenoid coils can be delivered for 12 V and 24 V supply voltages. For AC applications 120 V/ 60

Hz or 230 V/ 50 Hz. With the high power solenoid coils in AC variants, the rectifiers are integrated directly in the connector. By loosening the fixing nut (8), the solenoid coil can be replaced or turned in the range of 360°. The valve body is zinc coated.

Note:

The valves are supplied without solenoids coils. The solenoid coil, the terminal box and the housing body for line mounting have to be ordered separately.

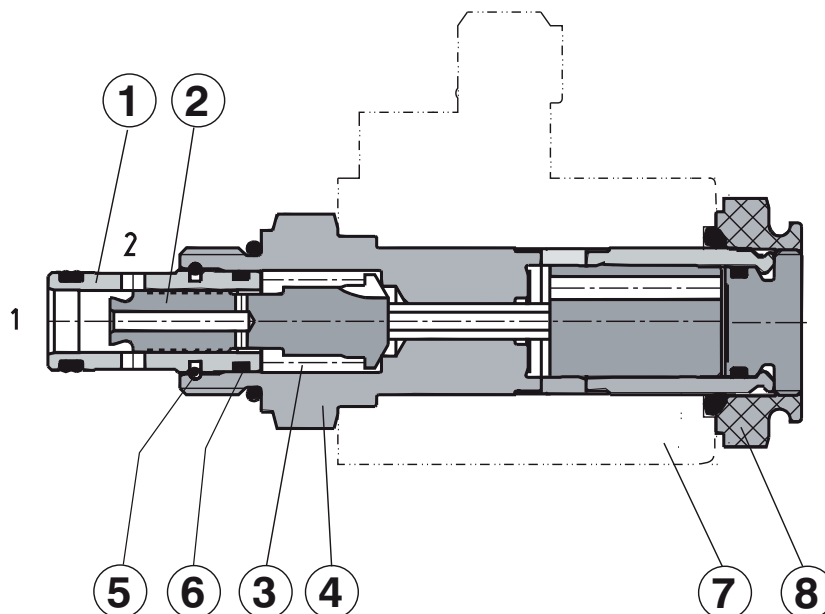

Ordering Code

SD2E-A2 /

**2/2 Way Solenoid Operated
Directional Control Valve Spool
3/4-16UNF**

**No designation
V**

**Seals
NBR
FPM (Viton)**

High performance H

**No designation
M2
M5
M9**

**Manual override
standard
covered with rubber boot
socket head screw
without manual override**

Description
Refer to the table with functional symbols

Solenoid coil, terminal box and body for line mounting have to be ordered separately. For selection of solenoid coil and terminal box type use catalogue HA 8007. For selection of valve body for in-line mounting use catalogue HA0018.

Functional Symbols

Designation	Symbol	Interposition	Designation	Symbol	Interposition
2111			2112		

Manual Override

Dimensions in millimeters (inches)

No designation - standard

Designation M9 - without manual override

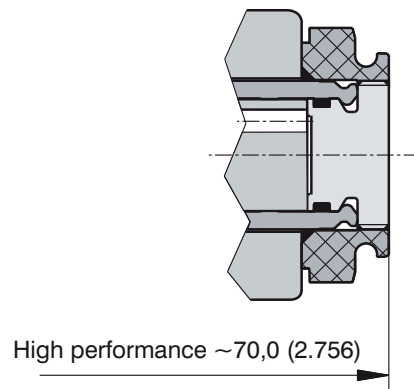
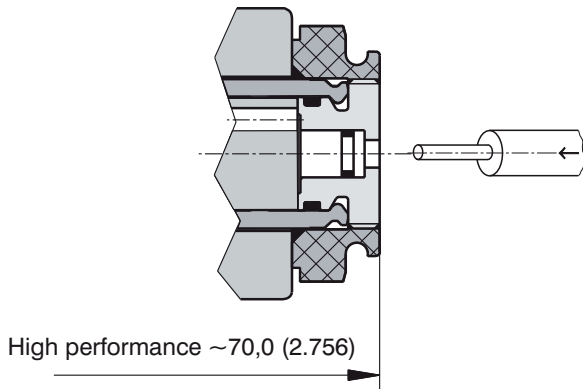

Designation M2 - covered with rubber boot

Designation M5 - with socket head screw 2.5 (0.098)

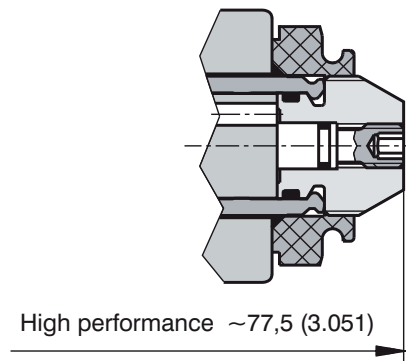
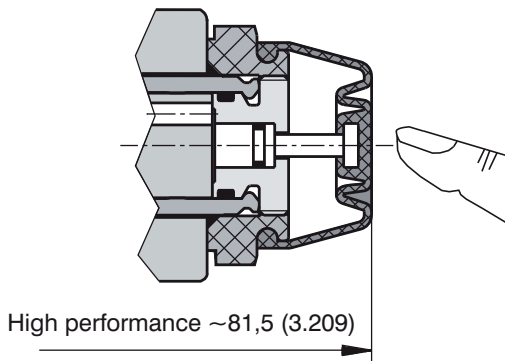

Technical Data

Valve size	A2	
Cartridge cavity	3/4-16 UNF-2A	
Maximum flow	L/min (GPM)	30 (7.9)
Max. operating pressure	bar (PSI)	350 (5076)
Pressure drop	bar (PSI)	see Δp -Q characteristics
Hydraulic fluid	Hydraulic oils of power classes (HL, HLP) to DIN 51524	
Coil groups ¹⁾	C19B	
Fluid temperature range	°C (°F)	-20 ... 80 (-4 ... 176)
Ambient temperature, max.	°C (°F)	-20 ... 80 (-4 ... 176)
Viscosity range	mm ² /s (SUS)	10 ... 500 (49 ... 2450)
Maximum degree of fluid contamination	Class 21/18/15 according to ISO 4406	
Permissible rated voltage variation	%	AC, DC \pm 15
Max. switching frequency	1/h	15 000
Duty cycle	%	100
Enclosure type to EN 60529 ¹⁾	IP 67 (IP 65)	
Service life	cycles	10 ⁷
Valve tightening torque	Nm (lbf.ft)	30+2 (22.127+1.475)
Plastic nut tightening torque	Nm (lbf.ft)	3+1 (2.213+0.738)
Weight	kg(lbs)	0,20 (0.44)
Mounting position	unrestricted	
Valve body (data sheed HA 0018)	SB-A2	

¹⁾ see data sheet coils HA 8007

p-Q Characteristic

Δp -Q Characteristic

Measured at $v = 32 \text{ mm}^2/\text{s}$ (156 SUS)

Operating limits for hydraulic power transferred by the directional valve.
For respective spool type - see functional symbols.

Oil 80 °C (176 °F) / Ambient temperature 50 °C (122 °F)
Voltage Un -10% [V] 24 VDC

Pressure drops related to flow rate.

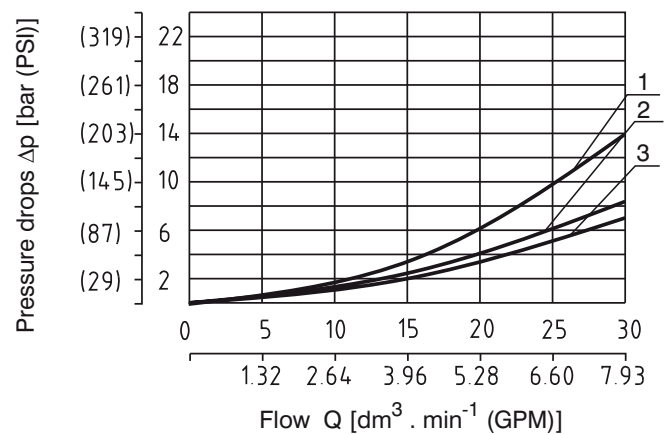
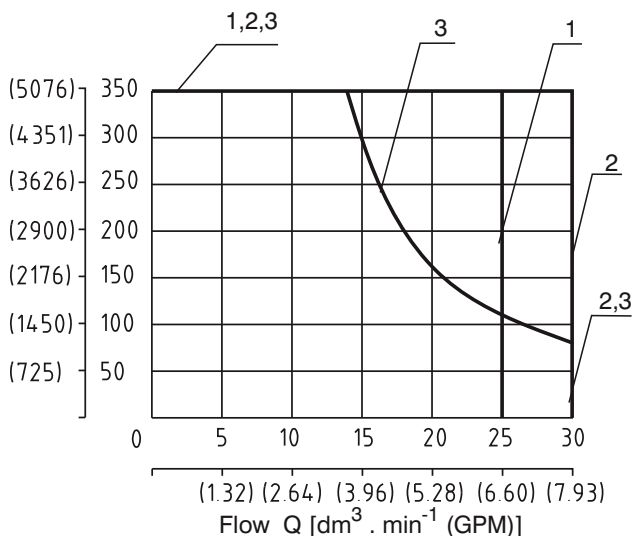

Type of the Solenoid Coils

Dimensions in millimeters (inches)

Example of most frequent coil types.

For complete range of valve coils with technical informatik about voltage, enclosure type, connectors please afer to coil data sheet HA 8007.

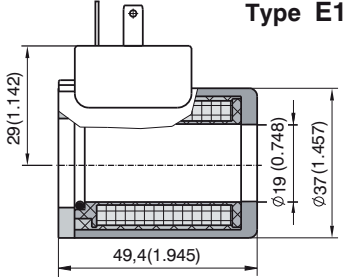
Coil example	Voltage	Connector	Type code
 <p>Type E1</p>	12 VDC	EN 175301-803-A	C19B-01200E1-7,1NA
	24 VDC	EN 175301-803-A	C19B-02400E1-28,8NA
	12 VDC	AMP Junior Timer	C19B-01200E3-7,1NA
	24 VDC	AMP Junior Timer	C19B-02400E3-28,8NA
	120 VAC	EN 175301-803-A with integrated rectifier	C19B-12060E5-527NA
	230 VAC	EN 175301-803-A with integrated rectifier	C19B-23050E5-2065NA
	120 VAC*	EN 175301-803-A	C19B-10600E1-527NA
	230 VAC*	EN 175301-803-A	C19B-20500E1-2065NA

*Use the connector plug with rectifier!

Valve Dimensions

Dimensions in millimeters (inches)

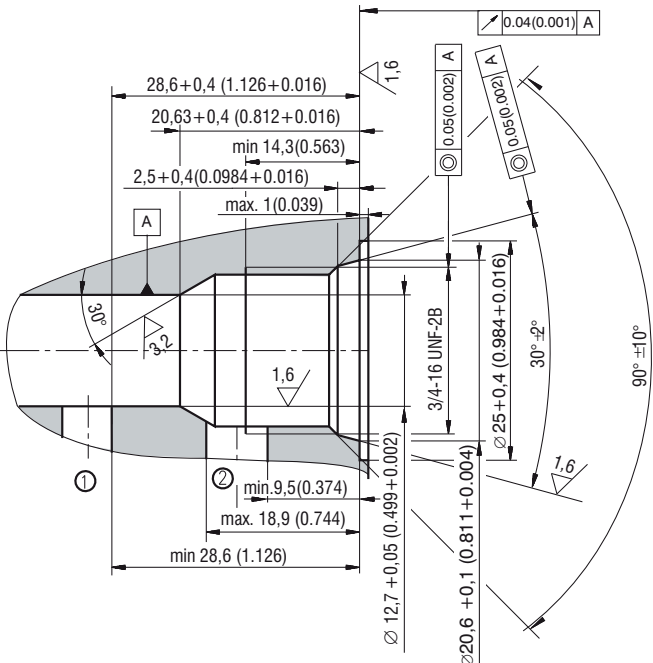
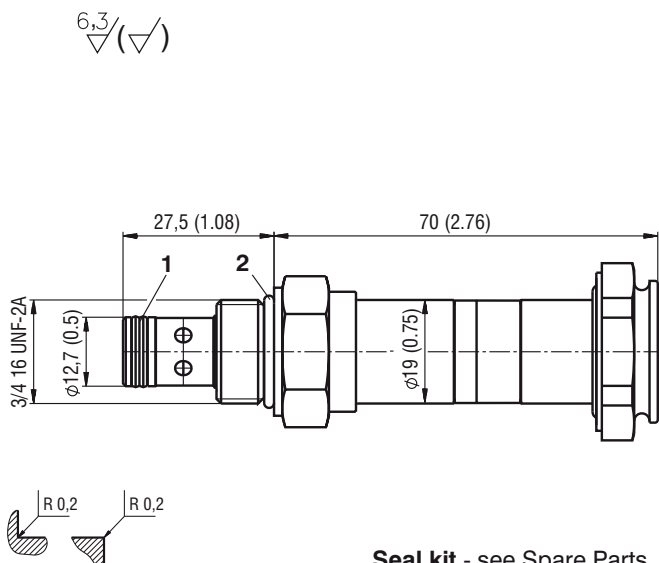
Cavity	Standard manual override
	 <p>Seal kit - see Spare Parts 1. Dualseal - PU 2. O-ring</p>

Spare Parts

Dimensions in millimeters

Seal kit			Ordering number (kit)
Dualseal - PU	O-ring - NBR	O-ring - Viton	
10,3 x 12,7 x 3,1 (1pc.)	17 x 1,8 (1pc.)	-	20776700
10,3 x 12,7 x 3,1 (1pc.)	-	17,17 x 1,78 (1pc.)	17014300
Type of nut			
Standard nut			20777000
Nut M2			20777600

Caution!

- The packing foil is recyclable.
- The technical information regarding the product presented in this catalogue is for descriptive purposes only. It should not be construed in any case as a guaranteed representation of the product properties in the sense of the law.

ARGO-HYTOS s.r.o. CZ - 543 15 Vrchlabí
 Tel.: +420-499-403 111
 E-mail: info.cz@argo-hytos.com
 www.argo-hytos.com

- Hardened precision working parts
- High flow capacity
- High transmitted hydraulic power
- Wide range of manual overrides available
- All ports may be fully pressurized
- Variety of optional spools connections available

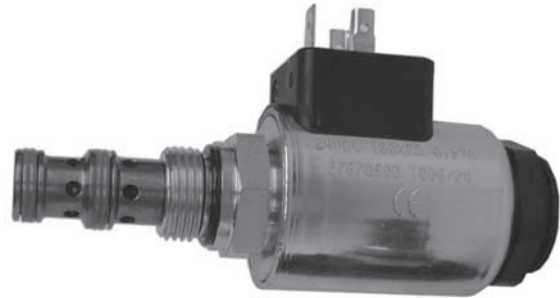
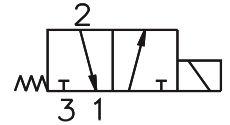

Functional Description

The directly operated 3/2 way solenoid actuated spool valve controls in the first line the start and stop function of the oil flow. The valve consists of the valve body (1), control spool (2), return spring (3), cartridge with actuating system (4) and of the solenoid coil (7).

The valve bushing is fixed in the cartridge by a wire ring (5) and sealed with the seal ring (6). Separation of the valve bushing and the cartridge prevent transmitting the stresses, which could be caused by too high tightening torques. The DC solenoid coils can be delivered for 12 V and 24 V supply voltages. For AC applications 120 V/ 60

Hz or 230 V/ 50 Hz. With the high power solenoid coils in AC variants, the rectifiers are integrated directly in the connector. By loosening the fixing nut (8), the solenoid coil can be replaced or turned in the range of 360°. The valve body is zinc coated.

Note:

The valves are supplied without solenoids coils. The solenoid coil, the terminal box and the housing body for line mounting have to be ordered separately.

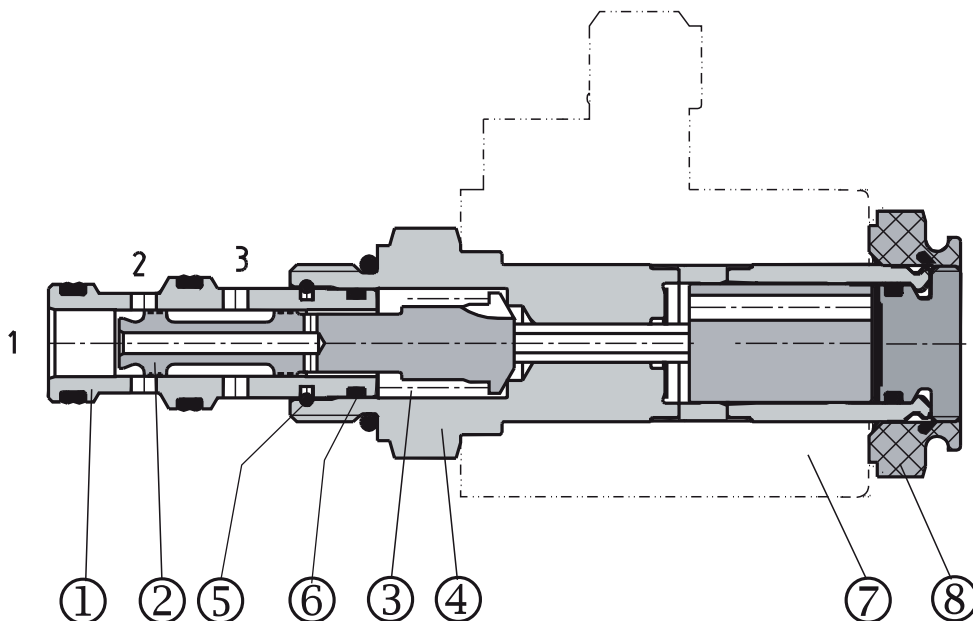

Ordering Code

SD2E-A3 /

**3/2 Way Solenoid Operated
Directional Control Valve
3/4-16UNF**

No designation
V

Seals
NBR
FPM (Viton)

High performance

H

No designation
M2
M5
M9

Manual override
standard
covered with rubber boot
socket head screw
without manual override

Description

Refer to the table with functional symbols

Solenoid coil, terminal box and body for line mounting have to be ordered separately. For selection of solenoid coil and terminal box type use catalogue HA 8007. For selection of valve body for in-line mounting use catalogue HA0018.

Functional Symbols

Designation	Symbol	Interposition	Designation	Symbol	Interposition
2D21			2D26		
2D25					

Manual Override

Dimensions in millimeters (inches)

No designation - standard

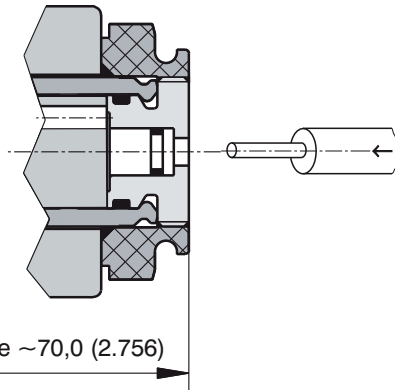

Designation **M9** - without manual override

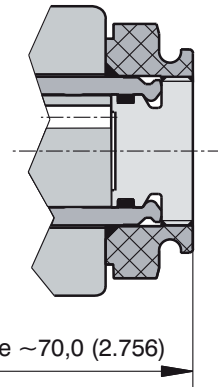

Designation **M2** - covered with rubber boot

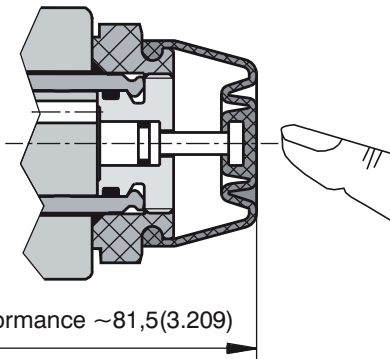

Designation **M5** - with socket head screw 2.5 (0.098)

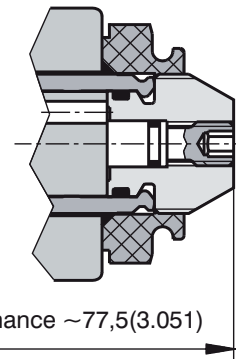

Technical Data

Valve size	A3	
Cartridge cavity	3/4-16 UNF-2A	
Maximum flow	L/min (GPM)	30 (7.9)
Max. operating pressure	bar (PSI)	350 (5076)
Pressure drop	bar (PSI)	see Δp -Q characteristics
Hydraulic fluid	Hydraulic oils of power classes (HL, HLP) to DIN 51524	
Fluid temperature range	°C (°F)	-20 ... 80 (-4 ... 176)
Ambient temperature, max.	°C (°F)	-20 ... 80 (-4 ... 176)
Viscosity range	mm ² /s (SUS)	10 ... 500 (49 ... 2450)
Maximum degree of fluid contamination	Class 21/18/15 according to ISO 4406	
Coil groups ¹⁾	C19B	
Permissible rated voltage variation	%	AC, DC ± 15
Max. switching frequency	1/h	15 000
Duty cycle	%	100
Enclosure type to EN 60529 ¹⁾	IP 67 (IP 65)	
Service life	cycles	10 ⁷
Valve tightening torque	Nm (lbf.ft)	30+2 (22.127+1.475)
Plastic nut tightening torque	Nm (lbf.ft)	3+1 (2.213+0.738)
Weight	kg(lbs)	0,20 (0.44)
Mounting position	unrestricted	
Valve body (data sheed HA 0018)	SB-A3	

¹⁾ see data sheet coils HA 8007

p-Q Characteristic

Δp -Q Characteristics

Operating limits for hydraulic power transferred by the directional valve.
For respective spool type - see functional symbols.

Measured at $v = 32 \text{ mm}^2/\text{s}$ (156 SUS)

Öl 80 °C (176 °F) / Ambient temperature 50 °C (122 °F)
Voltage Un -10% [V] 24 VDC

Pressure drops related to flow rate.

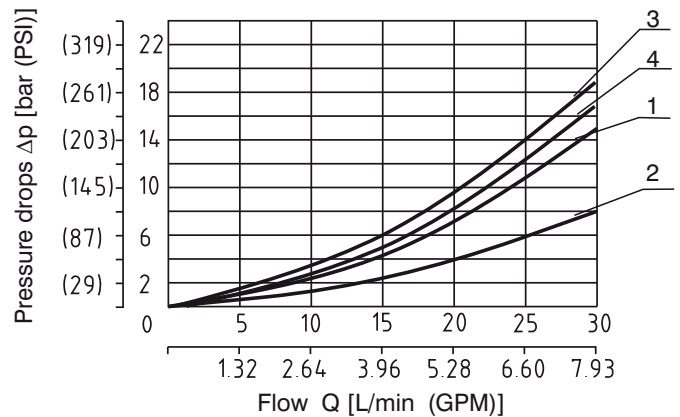
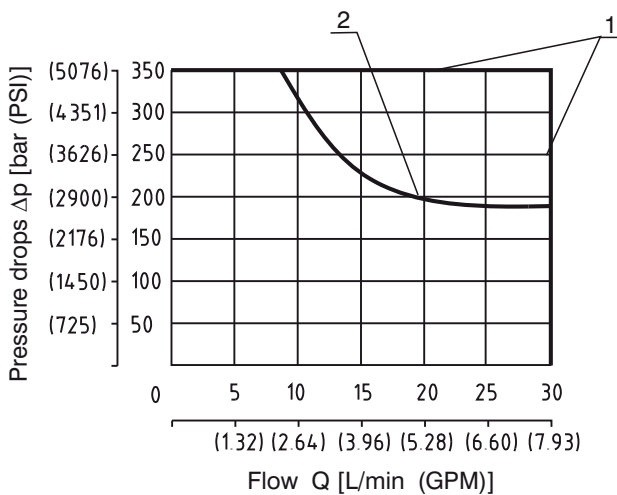

	Connection
1	2D21
1	2D25
2	2D26

	Connection	Direction
1	2D21	3→2
1	2D25	3→2
2	2D21	2→1
3	2D26	3→2
4	2D25	2→1
4	2D26	2→1

Type of the Solenoid Coils

Dimensions in millimeters (inches)

Example of most frequent coil types.

For complete range of valve coils with technical informatik about voltage, enclosure type, connectors please refer to coil data sheet HA 8007.

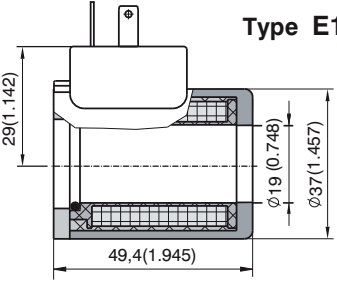
Coil example	Voltage	Connector	Type code
 <p>Type E1</p>	12 VDC	EN 175301-803-A	C19B-01200E1-7,1NA
	24 VDC	EN 175301-803-A	C19B-02400E1-28,8NA
	12 VDC	AMP Junior Timer	C19B-01200E3-7,1NA
	24 VDC	AMP Junior Timer	C19B-02400E3-28,8NA
	120 VAC	EN 175301-803-A with integrated rectifier	C19B-12060E5-527NA
	230 VAC	EN 175301-803-A with integrated rectifier	C19B-23050E5-2065NA
	120 VAC*	EN 175301-803-A	C19B-10600E1-527NA
	230 VAC*	EN 175301-803-A	C19B-20500E1-2065NA

*Use the connector plug with rectifier!

Valve Dimensions

Dimensions in millimeters (inches)

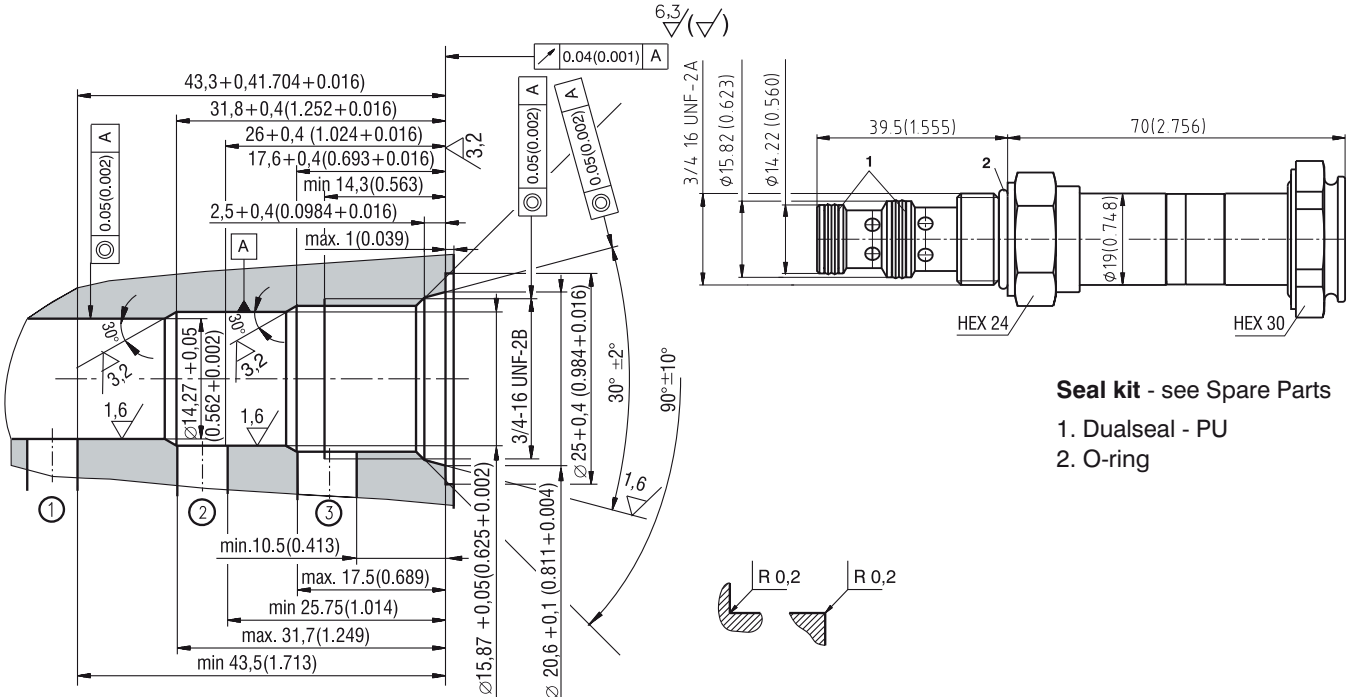
Cavity	Standard manual override
	
<p>Seal kit - see Spare Parts</p> <ol style="list-style-type: none"> 1. Dualseal - PU 2. O-ring 	

Spare Parts

Dimensions in millimeters

Seal kit			
Dualseal - PU	O-ring - NBR	O-ring - Viton	Ordering number
11,87 x 14,27 x 3,1 (1pc.)	17 x 1,8 (1pc.)	-	15661700
13,4 x 15,87 x 3,1 (1pc.)			
11,87 x 14,27 x 3,1 (1pc.)	-	17,17 x 1,78 (1pc.)	20777200
13,4 x 15,87 x 3,1 (1pc.)			
Type of nut			Ordering number
Standard nut			20777000
Nut M2			20777600

Caution!

- The packing foil is recyclable.
- The technical information regarding the product presented in this catalogue is for descriptive purposes only. It should not be construed in any case as a guaranteed representation of the product properties in the sense of the law.

ARGO-HYTOS s.r.o. CZ - 543 15 Vrchlabí
 Tel.: +420-499-403 111
 E-mail: info.cz@argo-hytos.com
 www.argo-hytos.com

- Hardened precision working parts
- High flow capacity
- High transmitted hydraulic power
- Wide range of manual overrides available
- All ports may be fully pressurized
- Variety of optional spools connections available

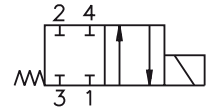

Functional Description

The directly operated 4/2 way solenoid actuated spool valve controls in the first line the start and stop function of the oil flow. The valve consists of the valve body (1), control spool (2), return spring (3), cartridge with actuating system (4) and of the solenoid coil (7).

The valve bushing is fixed in the cartridge by a wire ring (5) and sealed with the seal ring (6). Separation of the valve bushing and the cartridge prevent transmitting the stresses, which could be caused by too high tightening torques. The DC solenoid coils can be delivered for 12 V and 24 V supply voltages. For AC applications 120 V/ 60 Hz or 230 V/ 50 Hz,

With the high power solenoid coils in AC variants, the rectifiers are integrated directly in the connector. By loosening the fixing nut (8), the solenoid coil can be replaced or turned in the range of 360°. The valve body is zinc coated.

Note:

The valves are supplied without solenoids coils. The solenoid coil, the terminal box and the housing body for line mounting have to be ordered separately.

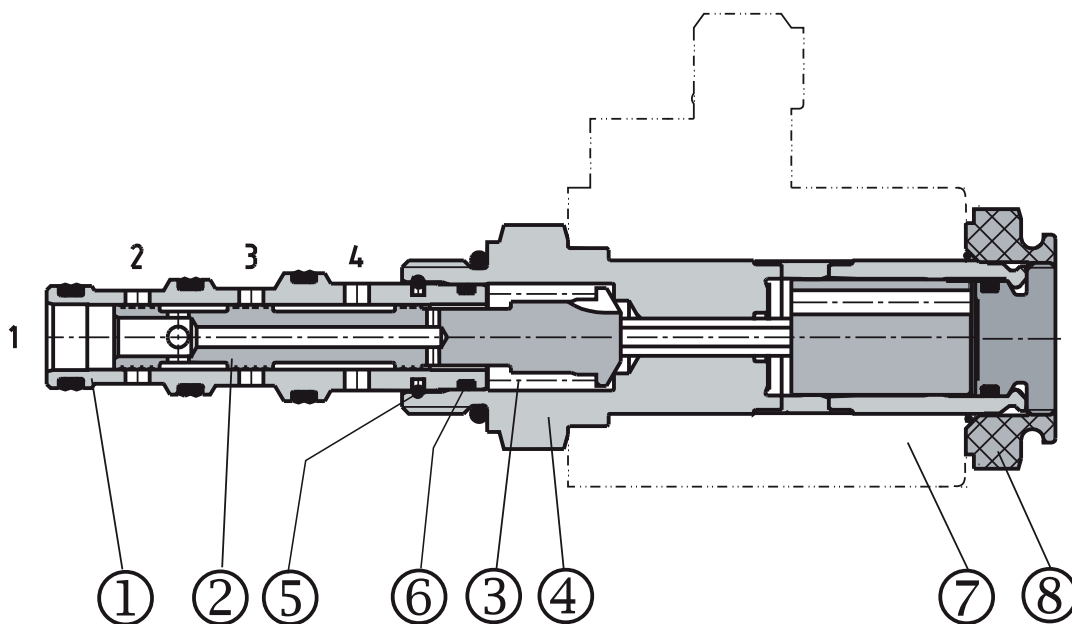

Ordering Code

SD2E-A4 /

4/2 Way Solenoid Operated Directional Control Valve
3/4-16UNF

No designation
V

Seals
NBR
FPM (Viton)

High Performance **H**

No designation
M2
M5
M9

Manual override
standard
covered with rubber boot
socket head screw
without manual override

Description
Refer to the table with functional symbols

Solenoid coil, terminal box and body for line mounting have to be ordered separately. For selection of solenoid coil and terminal box type use catalogue HA 8007. For selection of valve body for in-line mounting use catalogue HA0018.

Functional Symbols

Designation	Symbol	Interposition	Designation	Symbol	Interposition
2Z51			2X21		
2Z11			2R21		
2Y11					

Manual Override

Dimensions in millimeters (inches)

No designation - standard

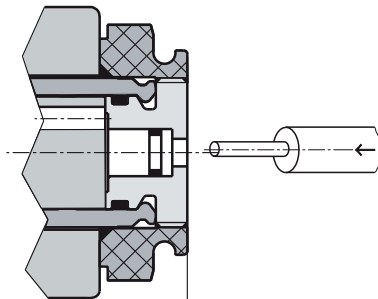

High performance ~70,0 (2.756)

Designation **M9** - without manual override

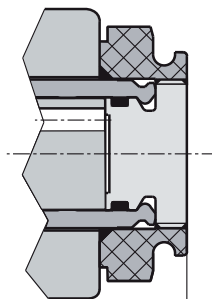

High performance ~70,0 (2.756)

Designation **M2** - covered with rubber boot

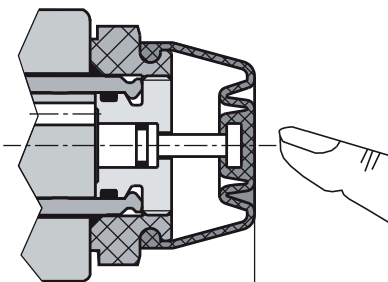

High performance ~81,5(3.209)

Designation **M5** - with socket head screw 2.5 (0.098)

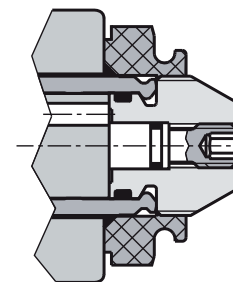

High performance ~77,5(3.051)

Technical Data

Valve size	A4	
Cartridge cavity	3/4-16 UNF- 2A (according to 17209)	
Maximum flow	L/min (GPM)	30 (7.9)
Max. operating pressure	bar (PSI)	350 (5076)
Pressure drop	bar (PSI)	see Δp -Q characteristics
Hydraulic fluid	Hydraulic oils of power classes (HL, HLP) to DIN 51524	
Coil groups ¹⁾	C19B	
Fluid temperature range	°C (°F)	-20 ... 80 (-4 ... 176)
Ambient temperature, max.	°C (°F)	-20 ... 80 (-4 ... 176)
Viscosity range	mm ² /s (SUS)	10 ... 500 (49 ... 2450)
Maximum degree of fluid contamination	Class 21/18/15 according to ISO 4406	
Permissible rated voltage variation	%	AC, DC ± 15
Max. switching frequency	1/h	15 000
Duty cycle	%	100
Enclosure type to EN 60529 ¹⁾	IP 67 (IP 65)	
Service life	cycles	10 ⁷
Weight	kg (lbs)	0,23 (0.51)
Valve tightening torque	Nm (lbf.ft)	30+2 (22.127+1.475)
Plastic nut tightening torque	Nm (lbf.ft)	3+1 (2.213+0.738)
Mounting position	unrestricted	
Valve body (data sheed HA 0018)	SB-A4	

¹⁾ see data sheet coils HA 8007

p-Q Characteristics

Measured at $v = 32\text{mm}^2/\text{s}$ (156 SUS)

Operating limits for maximum hydraulic power transferred by the directional valve.
For respective spool type - see functional symbols.

Oil 80 °C (176 °F) / Ambient temperature 50 °C(122 °F)
Voltage Un -10% [V] 24 VDC

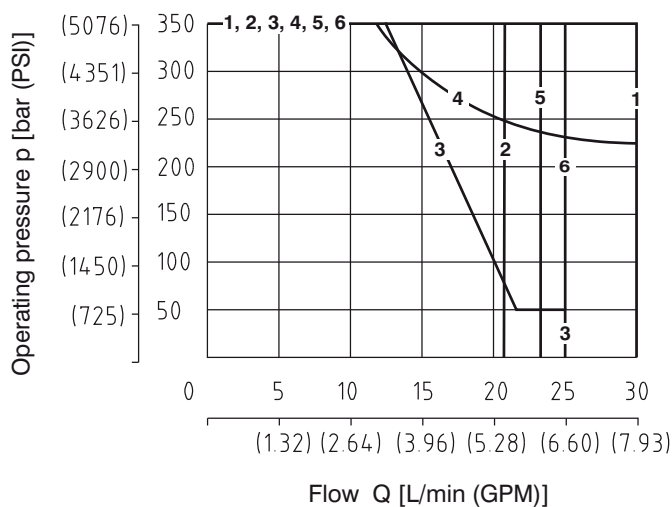

	Connection	Direction
1	2Z51	3→4
1	2Z51	2→1
2	2Z11	3→2
2	2Z11	4→1
3	2R21	3-2→4-1
4	2X21	3-4→2-1
5	2X21	3-2→4-1
1	2R21	3-4→2-1
6	2Y11	3-2→4-1

Δp-Q Characteristics

Measured at $v = 32\text{mm}^2/\text{s}$ (156 SUS)

Pressure drops related to flow rate.

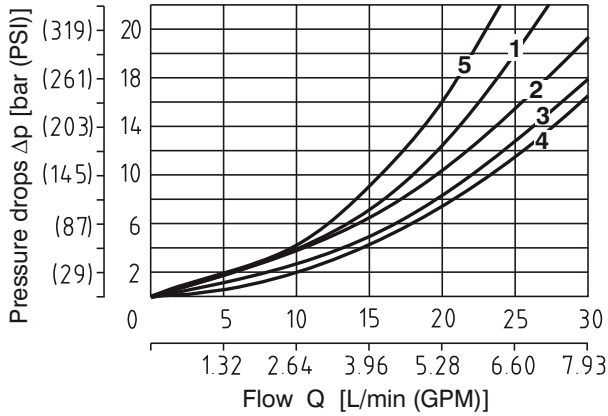

	Connection	Direction
1	2Z11	4→1
1	2R21	2→1
2	2Z11	3→2
2	2Z51	2→1
2	2X21	3→4
2	2X21	4→1
2	2R21	3→2
3	2Z51	3→4
4	2X21	3→2
3	2R21	3→4
4	2X21	2→1
5	2R21	4→1
3	2Y11	3→2
3	2Y11	4→1

Type of the Solenoid Coils

Dimensions in millimeters (inches)

Example of most frequent coil types.

For complete range of valve coils with technical informatik about voltage, enclosure type, connectors please refer to coil data sheet HA 8007.

Coil example	Voltage	Connector	Type code
<p>Type E1</p>	12 VDC	EN 175301-803-A	C19B-01200E1-7,1NA
	24 VDC	EN 175301-803-A	C19B-02400E1-28,8NA
	12 VDC	AMP Junior Timer	C19B-01200E3-7,1NA
	24 VDC	AMP Junior Timer	C19B-02400E3-28,8NA
	120 VAC	EN 175301-803-A with integrated rectifier	C19B-12060E5-527NA
	230 VAC	EN 175301-803-A with integrated rectifier	C19B-23050E5-2065NA
	120 VAC*	EN 175301-803-A	C19B-10600E1-527NA
	230 VAC*	EN 175301-803-A	C19B-20500E1-2065NA

*Use the connector plug with rectifier!

Valve Dimensions

Dimensions in millimeters (inches)

Standard manual override

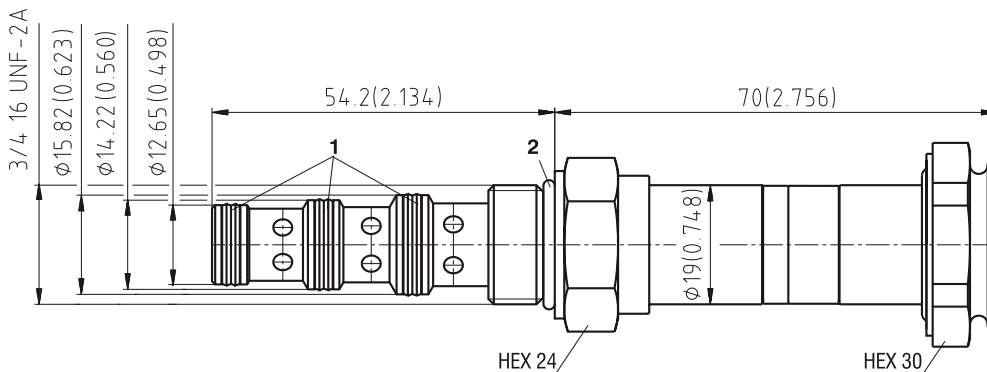

Seal kit - see Spare Parts
 1. Dualseal - PU
 2. O-ring

Cavity

Dimensions in millimeters (inches)

1

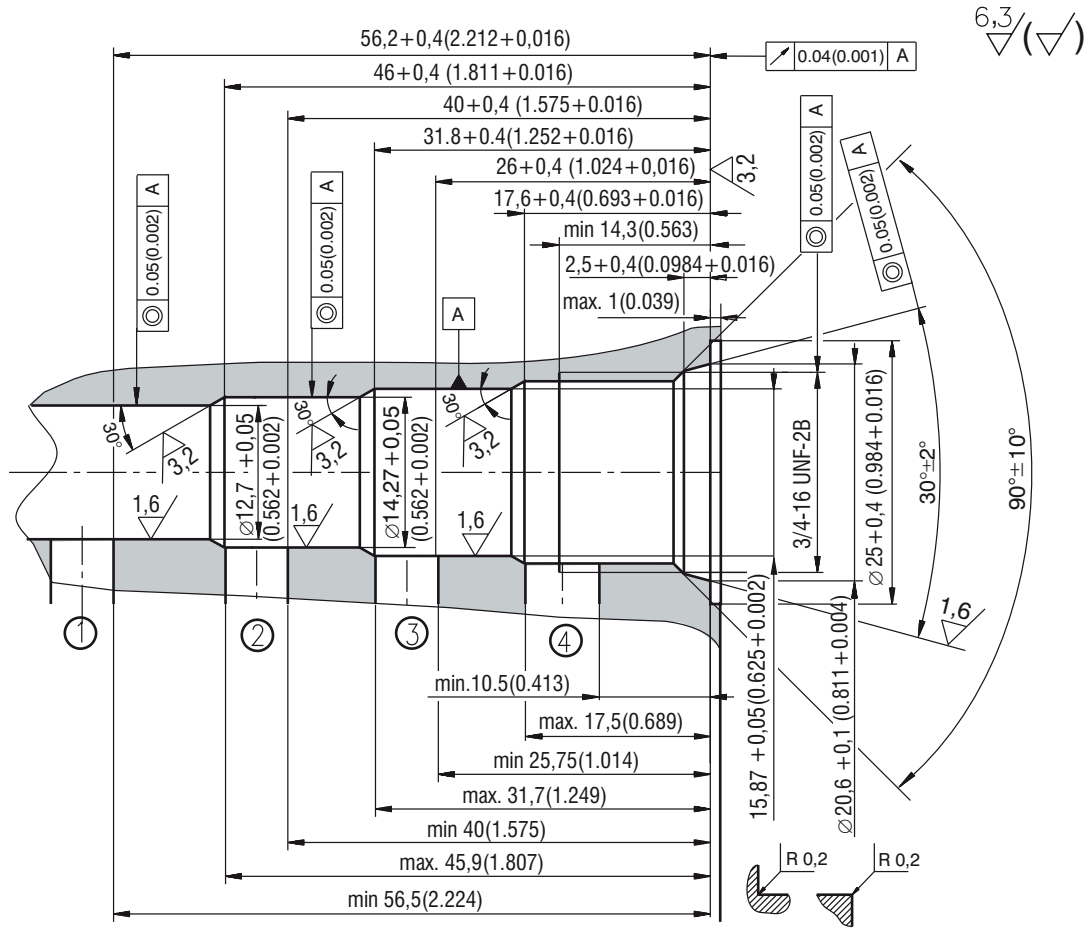

Spare Parts

Dimensions in millimeters

Seal kit			
Dualseal - PU	O-ring - NBR	O-ring - Viton	Ordering number
10,3 x 12,7 x 3,1 (1pc.)	17 x 1,8 (1pc.)	-	20777300
11,87 x 14,27 x 3,1 (1pc.)			
13,4 x 15,87 x 3,1 (1pc.)			
10,3 x 12,7 x 3,1 (1pc.)	-	17,17 x 1,78 (1pc.)	20777400
11,87 x 14,27 x 3,1 (1pc.)			
13,4 x 15,87 x 3,1 (1pc.)			
Type of nut		O-ring - Viton	Ordering number
Standard nut			20777000
Nut M2			20777600

Caution!

- The packing foil is recyclable.
- The technical information regarding the product presented in this catalogue is for descriptive purposes only. It should not be construed in any case as a guaranteed representation of the product properties in the sense of the law.

ARGO-HYTOS s.r.o. CZ - 543 15 Vrchlabí
Tel.: +420-499-403 111
E-mail: info.cz@argo-hytos.com
www.argo-hytos.com

- 2/2 way cartridge poppet valves solenoid operated
- Manual override
- High transmitted power
- Leakfree
(Less than 3 drops/min at 350 bar ((5076 PSI))

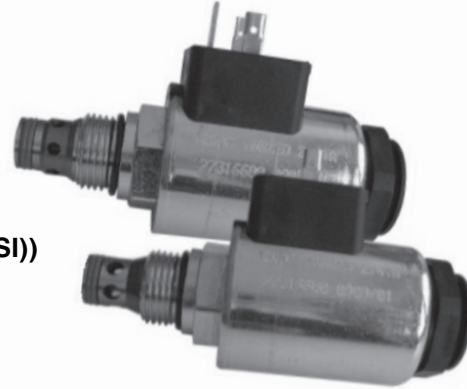
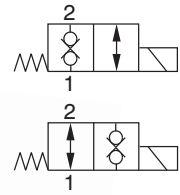

Functional Description

The directly controlled two-way two-position directional control poppet valve is used to open or close the medium flow to the consumer and, simultaneously, from the consumer to discharge. The typical example is control of a single-action cylinder. The control valve consists of the valve saddle (1), poppet (2), return spring (3) and controlling electromagnet (4). The opening and closing of the valve is ensured by the electromagnet controlled poppet which sits on the seat and guarantees it is in the closed, leak-free position. When

energized, the valve allows free flow in both directions, 1-2 or 2-1.

Coils are available for both DC or AC voltage. The solenoid coil can be replaced or adjusted up to 360° by loosening the fixing nut (5). The solenoid is zinc coated.

Note:

The valves are supplied without solenoid coils. The solenoid coil, the terminal box and the housing body for line mounting have to be ordered separately.

Designation 2S5

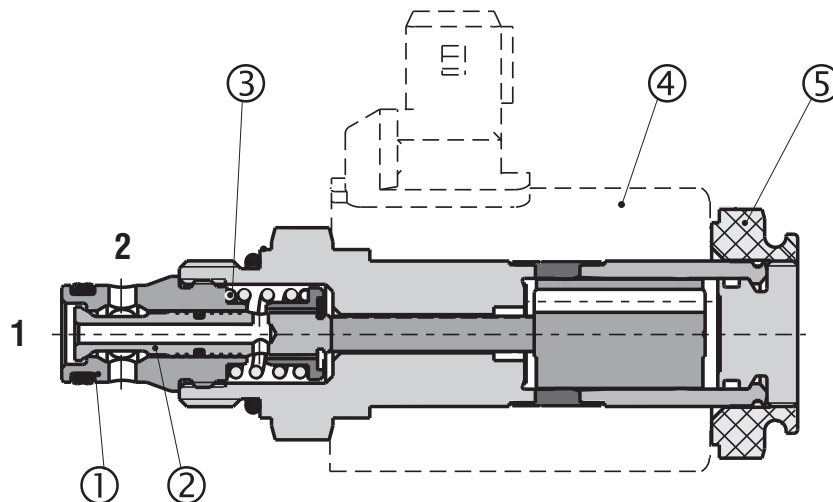

Designation 2S6

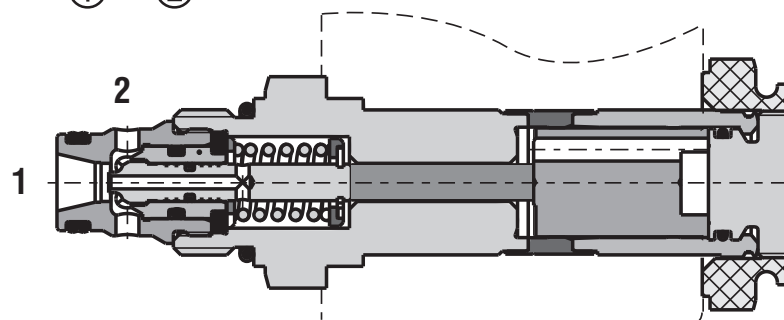

Ordering Code

SD1E-A2 /

**2/2 Way Solenoid Operated
Directional Control Poppet Valve
3/4-16UNF**

No designation
V

Seals
NBR
FPM (Viton)

High Performance

H

No designation
M2
M5
M9

Manual override
standard
covered with rubber boot
socket head screw
without manual override

Designation

Refer to the table with functional symbols

Solenoid coil, terminal box and body for line mounting have to be ordered separately. For selection of solenoid coil and terminal box type use catalogue HA 8007. For selection of valve body for in-line mounting use catalogue HA 0018.

Functional Symbols

Designation	Symbol	Designation	Symbol
2S5		2S6	

Manual Override

Dimensions in millimeters (inches)

No designation - standard

Designation M9 - without manual override

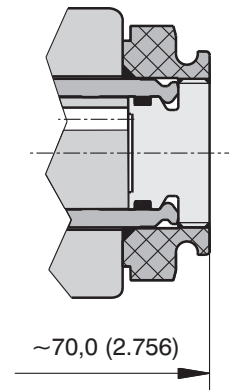
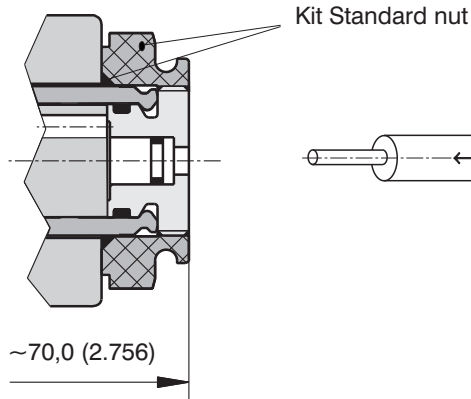

Designation M2 - covered with rubber boot

Designation M5 - with socket head screw 2.5 (0.098)

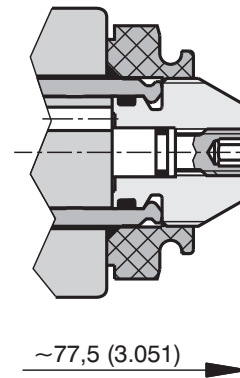
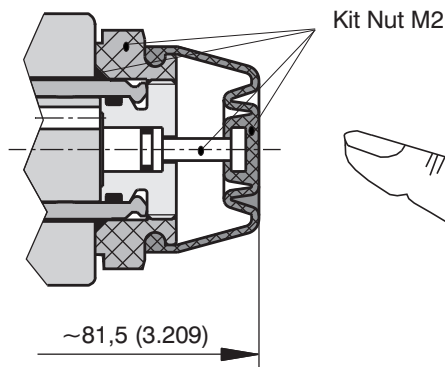

Technical Data

Valve size	A2	
Cartridge cavity	3/4-16 UNF-2A	
Maximum flow	L/min (GPM)	30 (7.9)
Max. operating pressure	bar (PSI)	350 (5076)
Pressure drop	bar (PSI)	see Δp-Q characteristics
Hydraulic fluid	Hydraulic oils of power classes (HL, HLP) to DIN 51524	
Fluid temperature range	°C (°F)	-20 ... 80 (-4 ... 176)
Ambient temperature, max.	°C (°F)	-20 ... 80 (-4 ... 176)
Viscosity range	mm ² /s (SUS)	10 ... 500 (49 ... 2450)
Maximum degree of fluid contamination	Class 21/18/15 according to ISO 4406	
Group coils ¹⁾	C19B	
Permissible rated voltage variation	%	± 15% AC,DC
Max. switching frequency	1/h	15 000
Duty cycle	%	100
Enclosure type to EN 60529	IP 65; IP 67 ¹⁾	
Service life	cycles	10 ⁷
Valve tightening torque	Nm (lbf.ft)	30+2 (22.127+1.475)
Plastic nut tightening torque	Nm (lbf.ft)	3+1 (2.213+0.738)
Weight	kg(lbs)	0,19 (0.42)
Mounting position	unrestricted	
Valve body (data sheed HA 0018)	SB-A2	

¹⁾ see data sheet coils HA 8007

p-Q Characteristics

Measured at $v = 32 \text{ mm}^2/\text{s}$ (156 SUS)

Operating limits for hydraulic power transferred by the directional valve. For respective spool type - see functional symbols.

Designation 2S5

Oil 80 °C (176 °F) / Ambient temperature 50 °C (122 °F)
Voltage Un -10% [V]

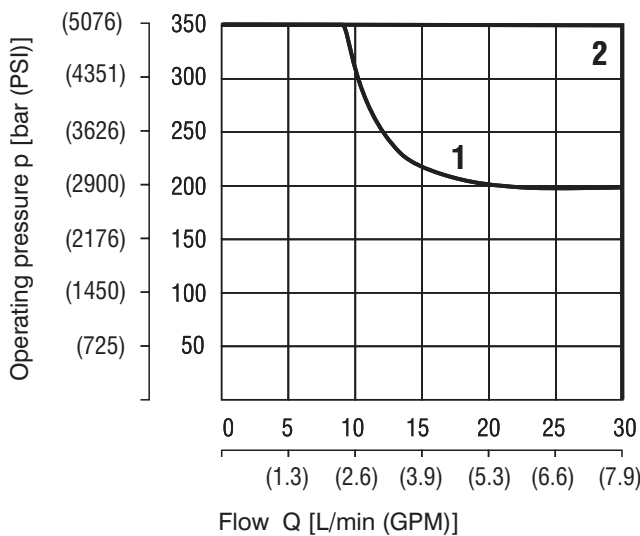

	Direction
1	1→2
2	2→1

Designation 2S6

Oil 80 °C (176 °F) / Ambient temperature 50 °C (122 °F)
Voltage Un -10% [V]

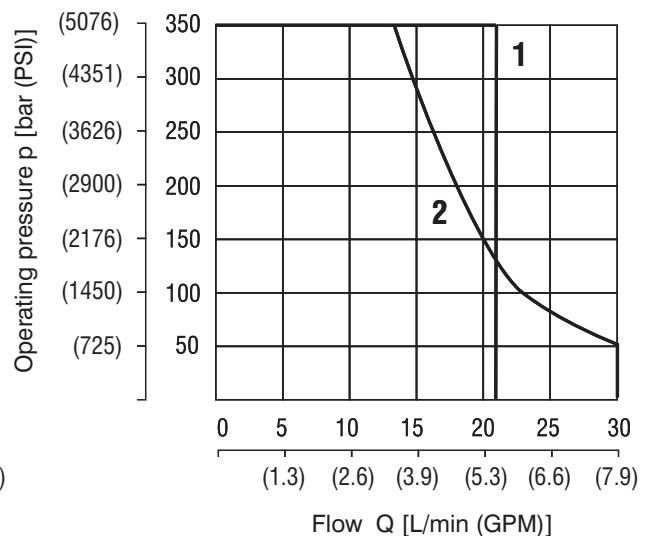

	Direction
1	2→1
2	1→2

Δp-Q Characteristics

Measured at $v = 32 \text{ mm}^2/\text{s}$ (156 SUS)

Pressure drops related to flow rate.

Designation 2S5

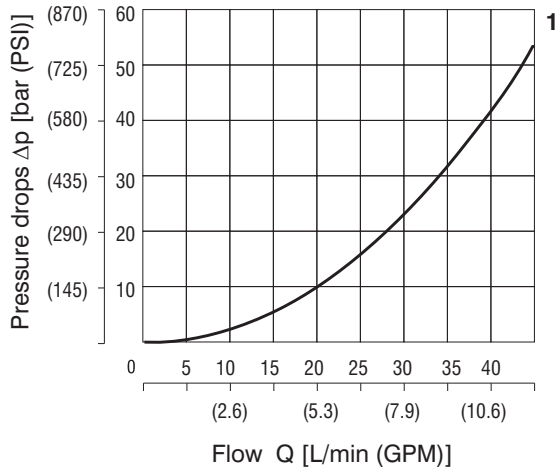

	Direction
1	1→2
1	2→1

Designation 2S6

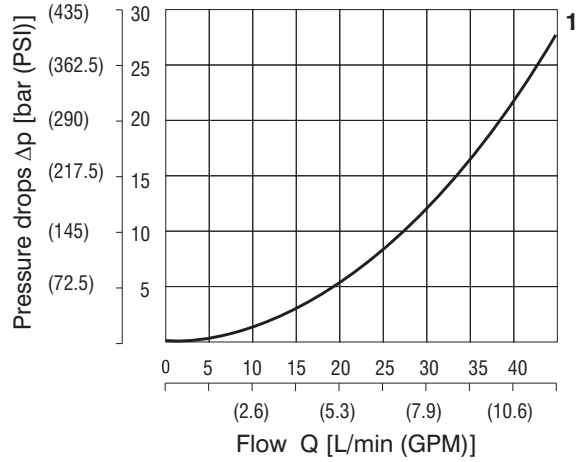

	Direction
1	1→2
1	2→1

Type of the Solenoid Coils

Dimensions in millimeters (inches)

Coil C19B
with connector E1 (E2)

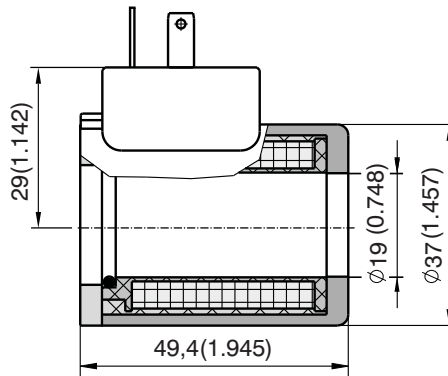

Note:

Example of most frequent coil types.

For complete range of SD1E-A2 valve coils with technical information about voltage, enclosure type, terminal box please refer to coil data sheet HA 8007.

Voltage	Connector	High performance
		SD1E-A2 / H... Type code
12 VDC	EN 175301-803-A	C19B-01200E1-6NA
24 VDC	EN 175301-803-A	C19B-02400E1-25,75NA
12 VDC	AMP Junior Timer	C19B-01200E3-6NA
24 VDC	AMP Junior Timer	C19B-02400E3-25,75NA
120 VAC	EN 175301-803-A with integrated rectifier	C19B-12060E5-494NA
230 VAC	EN 175301-803-A with integrated rectifier	C19B-23050E5-1653NA
120 VAC	EN 175301-803-A Use the connector plug with rectifier!	C19B-10600E1-494NA
230 VAC	EN 175301-803-A Use the connector plug with rectifier!	C19B-20500E1-1653NA

Valve Dimensions

Dimensions in millimeters (inches)

Designation 2S5

Designation 2S6

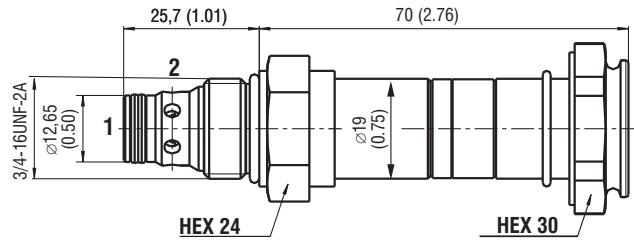
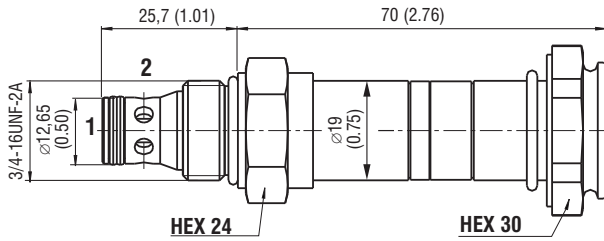
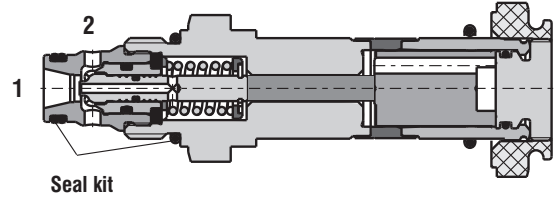
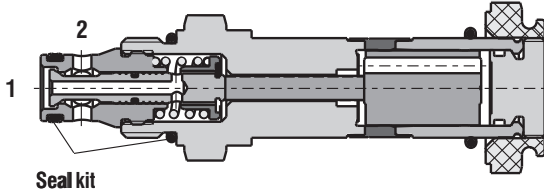

Seal kit - see Spare Parts
 Dualseal - PU
 O-ring

Cavity

Dimensions in millimeters (inches)

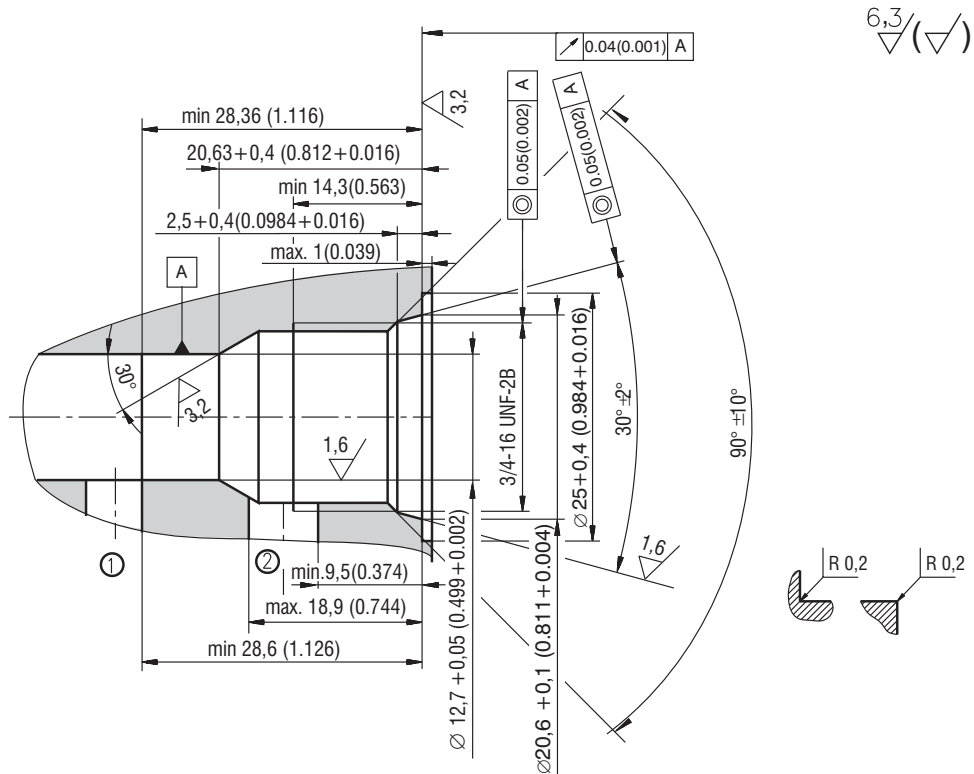

Spare Parts

Dimensions in millimeters (inches)

Seal kit

Dualseal - PU	O-ring - NBR	O-ring - Viton	Ordering number
10,3 x 12,7 x 3,1 (1pc.)	17 x 1,8 (1pc.)	-	20776700
10,3 x 12,7 x 3,1 (1pc.)	-	17,17 x 1,78 (1pc.)	17014300

Type of nut

Kit Standard nut	Nut +O-ring	20777000
Kit Nut M2	Nut +O-ring + Rubber cap + Pin	20777600

Caution!

- The packing foil is recyclable.
- The technical information regarding the product presented in this catalogue is for descriptive purposes only. It should not be construed in any case as a guaranteed representation of the product properties in the sense of the law.

ARGO-HYTOS s.r.o. CZ - 543 15 Vrchlaví
 tel.: +420-499-403 111
 e-mail: info.cz@argo-hytos.com
 www.argo-hytos.com

- Screw-in cartridge and in-line design
- Poppet valve - leak-free closing
- High switching reliability after long idling time
- Short switching times

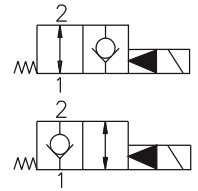

Functional Description

The pilot operated 2/2 way solenoid actuated poppet valves control in the first line the start and stop function of the oil flow. The valve consists of the valve bushing (1), main control spool (2), return spring (3), cartridge with actuating system (4) and of the solenoid coil (5) that is mounted on the actuating system. The valve bushing is screwed into the cartridge part.

In the variant normally closed / normally open, the valve is securely held in the respective basic position by a spring. By energizing the solenoid coil the spring force is overcome and the pilot valve is pressed onto the seat or lifted. Opening and closing of the main control spool is hydraulically supported through the orifice boring created in the main control spool.

The DC solenoid coils can be delivered for 12 V and 24 V supply voltages. For AC applications 120 V/60 Hz or 230 V/ 50 Hz. With the AC high power solenoid coils, the rectifiers are integrated directly in the connector. By loosening the fixing nut (6), the solenoid coil can be replaced or turned in the range of 360°.

Notice.

The valves are supplied without solenoids coils. The solenoid coil, the terminal box and the body for line mounting have to be ordered separately.

Absence of current opened 2O2

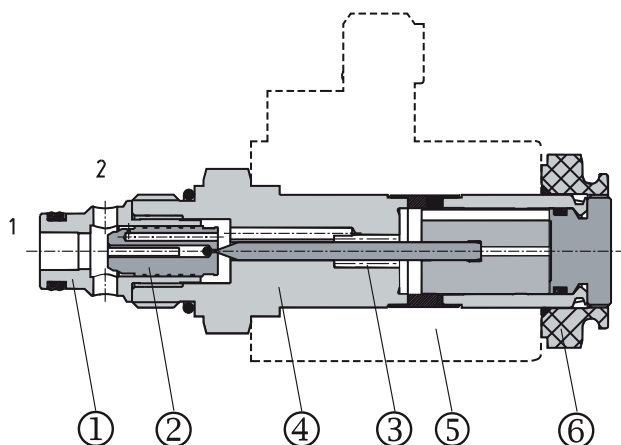

Absence of current closed 2L2

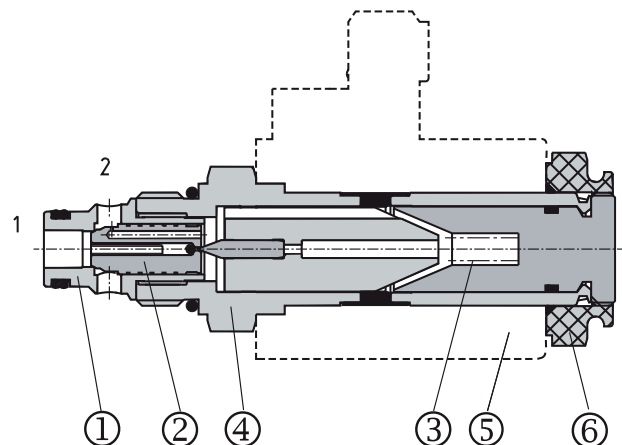

Ordering Code

SD3E-A2 /

**2/2 Way Solenoid Operated
Directional Control Valve
Poppet Type 3/4-16UNF**

**No designation
V**

Seals
NBR
FPM (Viton)

High Performance **H**

No designation standard only for 2O2
M2 covered with rubber bootn only for 2O2
M5 socket head screw
M9 without manual override

Description
Refer to the table with functional symbols

Solenoid coil, terminal box and body for line mounting have to be ordered separately. For selection of solenoid coil and terminal box type use catalogue HA 8007. For selection of valve body for in-line mounting use catalogue HA0018.

Functional Symbols

Designation	Symbol	Designation	Symbol
2O2		2L2	

Manual Override

Dimensions in millimeters (inches)

No designation - Standard only for 2O2

Designation **M9** - only for 2L2
without manual override

Designation **M9** - only for 2O2
without manual override

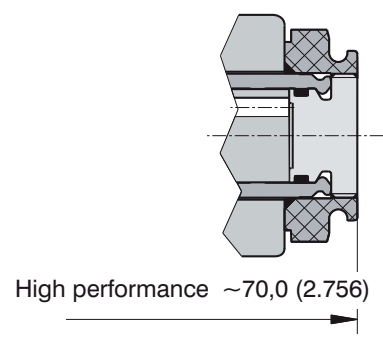
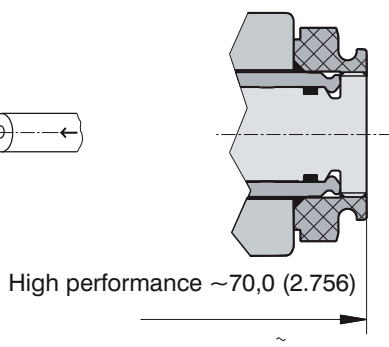
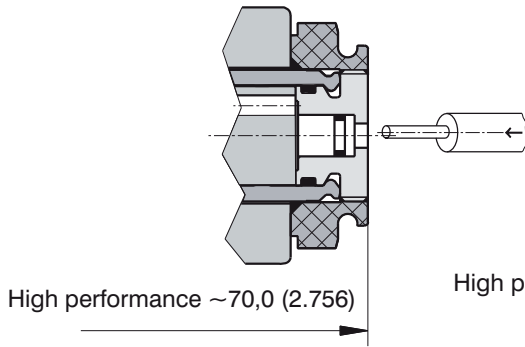

Designation **M2** - only for 2O2
covered with rubber bootn

Designation **M5** - only for 2O2
by screwing in of the socket head
screw 2,5(0.098)

Designation **M5** - only for 2L2
by screwing in of the socket
head screw 2,5(0.098)

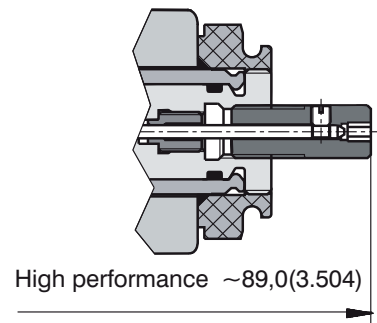
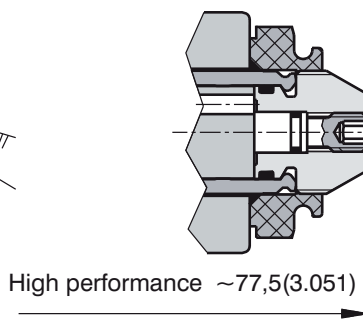
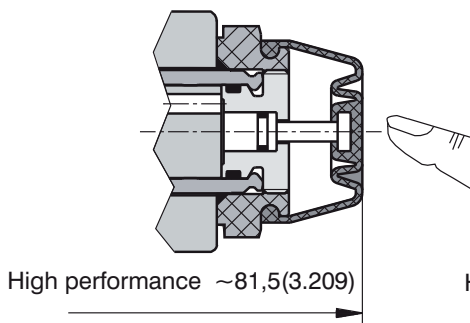

Technical Data

Valve size	A2	
Cartridge cavity	3/4-16 UNF -2A	
Maximum flow	L/min (GPM)	30 (7.9)
Max. operating pressure	bar (PSI)	420 (6091)
Pressure drop	bar (PSI)	see Δp -Q characteristics
Hydraulic fluid	Hydraulic oils of power classes (HL, HLP) to DIN 51524	
Coil groups ¹⁾	C19B	
Fluid temperature range	°C (°F)	-20 ... 80 (-4 ... 176)
Ambient temperature, max.	°C (°F)	-20 ... 80 (-4 ... 176)
Viscosity range	mm ² /s (SUS)	10 ... 500 (49 ... 2450)
Maximum degree of fluid contamination	Class 21/18/15 according to ISO 4406.	
Permissible rated voltage variation	%	AC, DC ± 15
Max. switching frequency	1/h	15 000
Duty cycle	%	100
Service life	cycles	10 ⁷
Enclosure type to EN 60529 ¹⁾	IP 67 (IP 65)	
Weight	kg (lbs)	0,20 (0.44)
Valve tightening torque	Nm (lbf.ft)	30+2 (22.127+1.475)
Plastic nut tightening torque	Nm (lbf.ft)	3+1 (2.213+0.738)
Mounting position	unrestricted	
Valve body (data sheed HA 0018)	SB-A2	

¹⁾ see data sheet coils HA 8007

p-Q Characteristics

Δp -Q Characteristic

Operating limits for hydraulic power transferred by the directional valve.
For respective spool type - see functional symbols.

Measured at $v = 32 \text{ mm}^2/\text{s}$ (156 SUS)

Oil 80 °C (176 °F) / Ambient temperature 50 °C (122 °F)
Voltage Un -10% [V] 24 VDC

Pressure drops related to flow rate

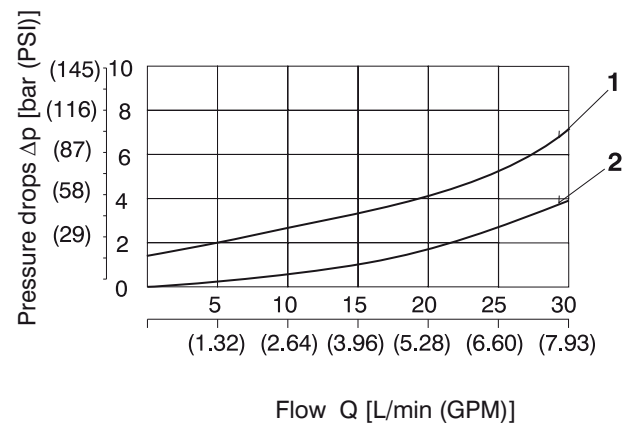
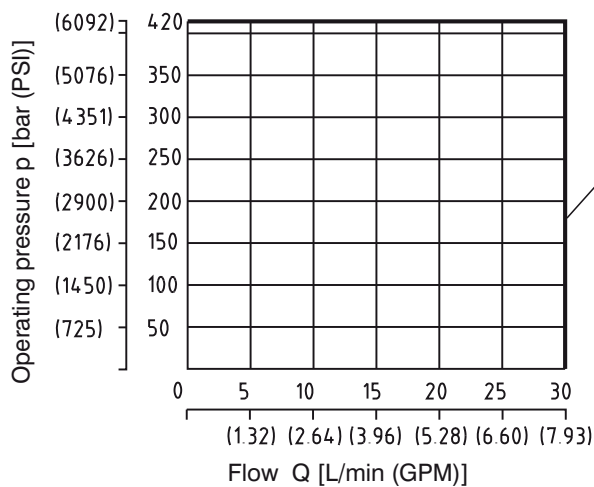

	Connection
1	2L2
1	2O2

	Connection	Dirrection	Solenoid
1	H2L2	1 → 2	switched off
2	H2L2	1 → 2	switched on
2	H2L2	2 → 1	switched on
2	H2O2	1 → 2	switched off
2	H2O2	2 → 1	switched off

Type of the Solenoid Coils

Dimensions in millimeters (inches)

Example of most frequent coil types.

For complete range of valve coils with technical informatik about voltage, enclosure type, connectors please refer to coil data sheet HA 8007.

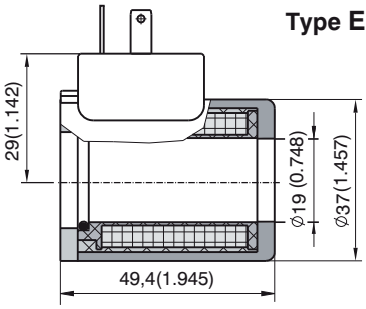
Coil example	Voltage	Connector	Type code
 <p>Type E1</p>	12 VDC	EN 175301-803-A	C19B-01200E1-7,1NA
	24 VDC	EN 175301-803-A	C19B-02400E1-28,8NA
	12 VDC	AMP Junior Timer	C19B-01200E3-7,1NA
	24 VDC	AMP Junior Timer	C19B-02400E3-28,8NA
	120 VAC	EN 175301-803-A with integrated rectifier	C19B-12060E5-527NA
	230 VAC	EN 175301-803-A with integrated rectifier	C19B-23050E5-2065NA
	120 VAC*	EN 175301-803-A	C19B-10600E1-527NA
	230 VAC*	EN 175301-803-A	C19B-20500E1-2065NA

*Use the connector plug with rectifier!

Valve Dimensions

Dimensions in millimeters (inches)

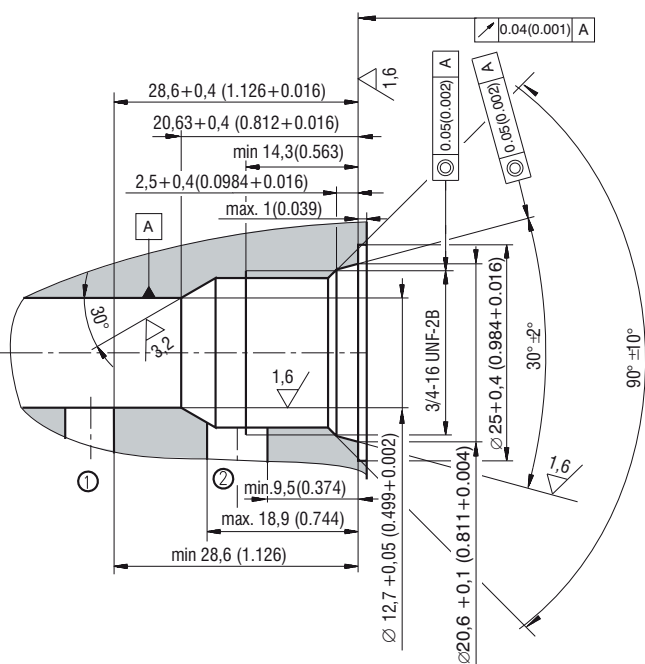
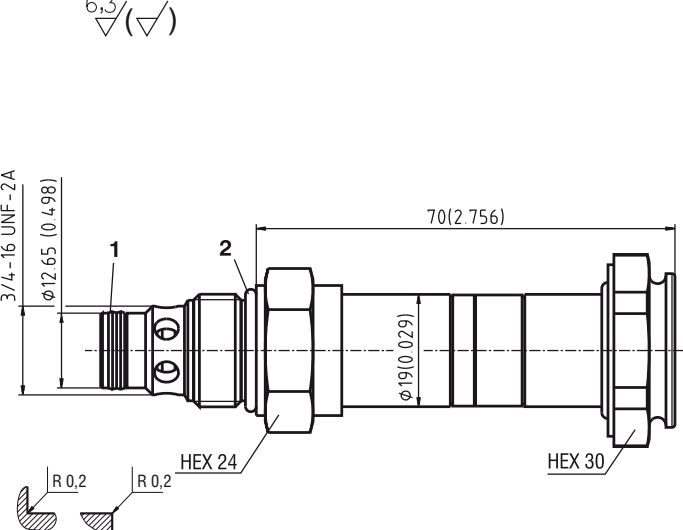
Cavity	Standard manual override
	 <p>Seal kit - see Spare Parts 1. Dualseal - PU 2. O-ring</p>

Spare Parts

Dimensions in millimeters

Seal kit			
Dualseal - PU	O-Ring - NBR	O-Ring - Viton	Ordering number (kit)
10,3 x 12,7 x 3,1 (1pc.)	17 x 1,8 (1pc.)	-	20776700
10,3 x 12,7 x 3,1 (1pc.)	-	17,17 x 1,78 (1pc.)	17014300
Type of nut			
Standard nut			20777000
Nut M2			20777600

Caution!

- The packing foil is recyclable.
- The technical information regarding the product presented in this catalogue is for descriptive purposes only. It should not be construed in any case as a guaranteed representation of the product properties in the sense of the law.

ARGO-HYTOS s.r.o. CZ - 543 15 Vrchlábí
 Tel.: +420-499-403 111
 E-mail: info.cz@argo-hytos.com
 www.argo-hytos.com

- Poppet design - leakfree closure
- Simple design
- 2 models

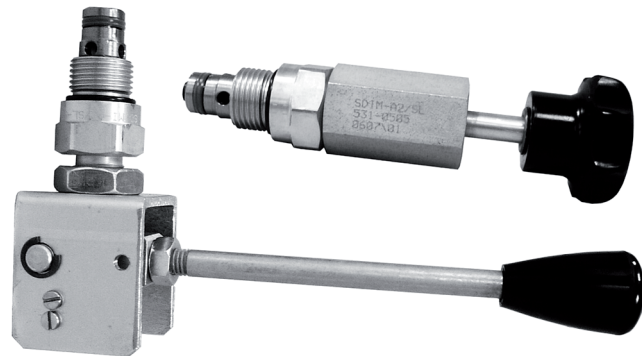
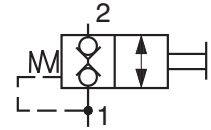

Functional Description

The 2/2 poppet type directional control valves are designed to check and open flow of the hydraulic fluid. Additionally, they can also provide flow throttling.

The valve consists of the housing (1), the poppet (2) and the actuating section (3).

Opening and closing of the valve is handled by a poppet. The poppet is pushed onto the seat by a spring, thus providing leakfree closure of the valve. The poppet can be operated by a push hand knob or a hand lever. The model with the hand knob (3) has 2 operating positions. After releasing the hand knob, the spring returns the valve into its closed position. The model with a hand lever in fact also has only two operating

positions, but the hand lever can be set to 3. position. These are as follows:

Position 0, middle hand lever position - the valve is closed by means of the return spring.

Position I. opens the valve against the return spring.

Position II. actuates a contact (with the model with micro switch), e.g. in order to turn on the pump motor by means of a switching relay. With the model without microswitch, this position also exists, but it does not have any function.

Caution! The preferential flow direction is 2 → 1 because of smaller operating forces.

The basic surface treatment of the valve is zinc coating.

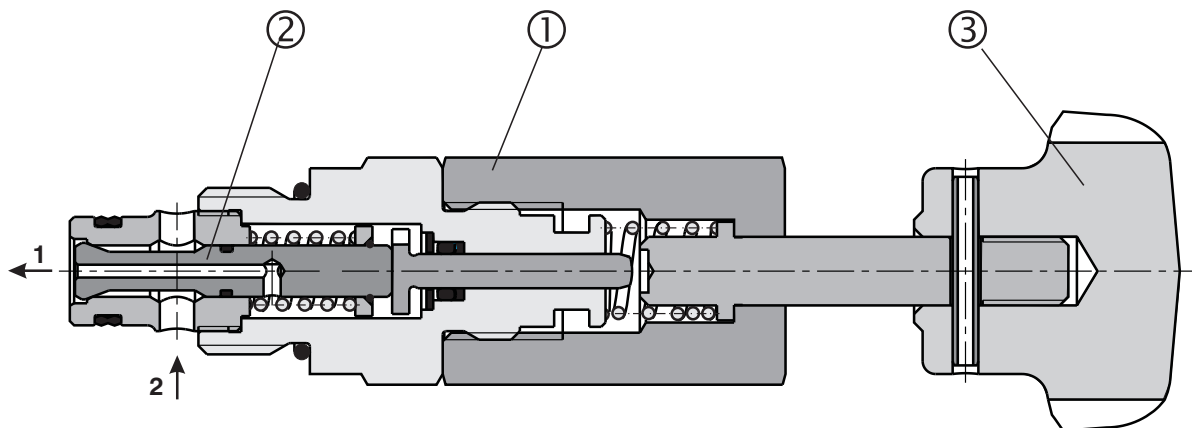

Ordering Code

SD1M-A2/SL

**2 Way Poppet Type Valve
Hand Operated - 3/4-16 UNF**

**no designation
V**

Seals
Standard (NBR)
Viton (FPM)

Description
Normally closed

**1
2
3**

Model
with hand knob
with hand lever without microswitch
with hand lever with microswitch

Technical Data

Valve size		A2
Nominal size	mm (US)	3/4-16 UNF-2A
Maximum flow	L/min (GPM)	20 (5.28)
Max. operating pressure	bar (PSI)	250 (3625.9)
Pressure drop	bar (PSI)	see Δp characteristics
Hydraulic fluid		Hydraulic oils of power classes (HL, HLP) to DIN 51524
Fluid temperature range - NBR	°C (°F)	-30 ... +100 (-22... +212)
Fluid temperature range - Viton	°C (°F)	-20 ... +120 (-4 ... +248)
Viscosity range	mm ² /s (SUS)	10 ... 500 (49 ... 2450)
Maximum degree of fluid contamination		Class 21/18/15 to ISO 4406
Weight - model 1		0.274 (0.604)
model 2	kg (lbs)	0.381 (0.840)
model 3		0.383 (0.844)
Service life	cycles	10 ⁶
Mounting position		unrestricted
Valve body (data sheet HA 0018)		SB-A2
Microswitch		D2SW-3D
Enclosure type of microswitch to EN 60529		IP 67
Microswitch data		2A - 250 V ~ 0,1A - 30 V =

Δp -Q Characteristics

Measured at $v = 32 \text{ mm}^2/\text{s}$ (156 SUS)

Pressure drop Δp related to flow rate.

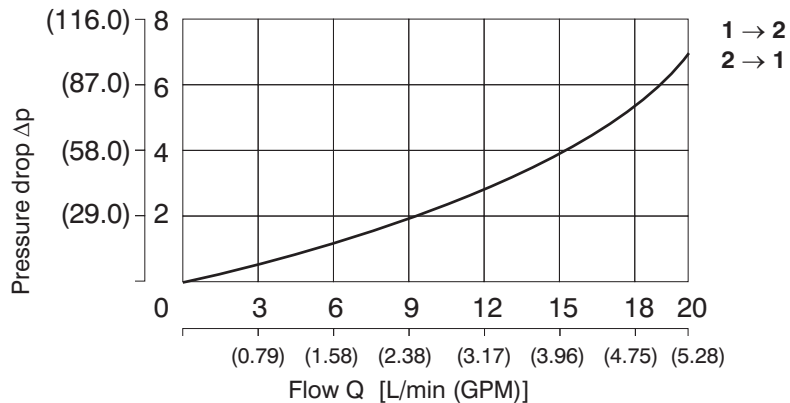

Valve Dimensions

Dimensions in millimeters (inches)

Typ: SD1M-A2/SL1

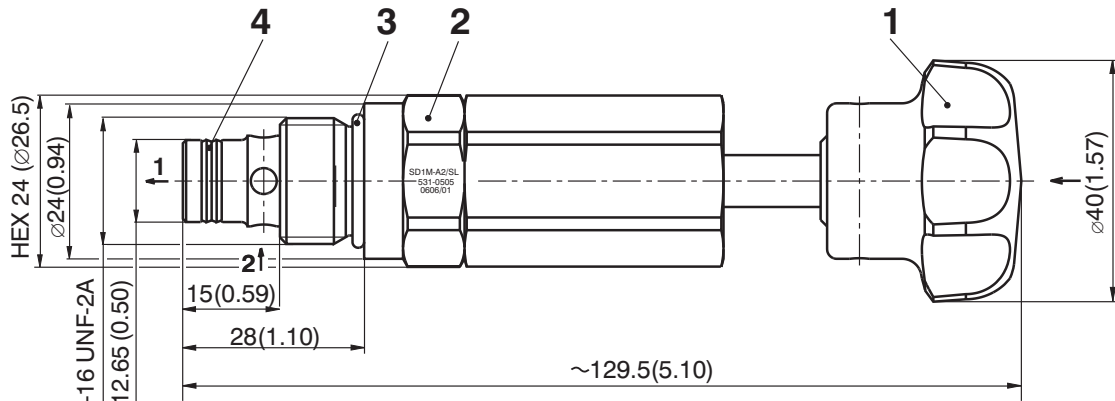

- 1 Push hand knob
- 2 Outside hexagon 24 mm (0.94 inch)
Tightening torque 30 Nm (22.1 lbs)
- 3 Seal: O-ring 17 x 1,8
(supplied with valve)
- 4 Seal:
Dualseal 10,3 x 12,7 x 3,1
(supplied with valve)

Cavity

Dimensions in millimeters (inches)

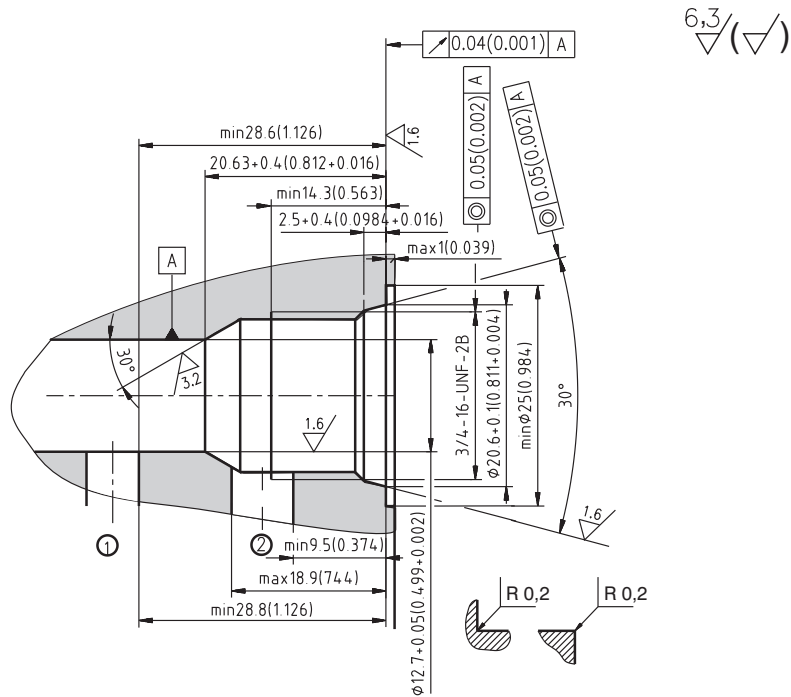

Spare Parts

Seal kit

Type	Dimensions, quantity		Ordering number
	O-Ring	Dualseal - PU	
Standard - NBR	17 x 1,8 (1ks)	10,3 x 12,7 x 3,1 (1ks)	22752500
Viton	17,17x1,78 (1ks)	10,3 x 12,7 x 3,1 (1ks)	22752600

Valve Dimensions

Dimensions in millimeters (inches)

Typ: SD1M-A2/SL2 and SD1M-A2/SL3

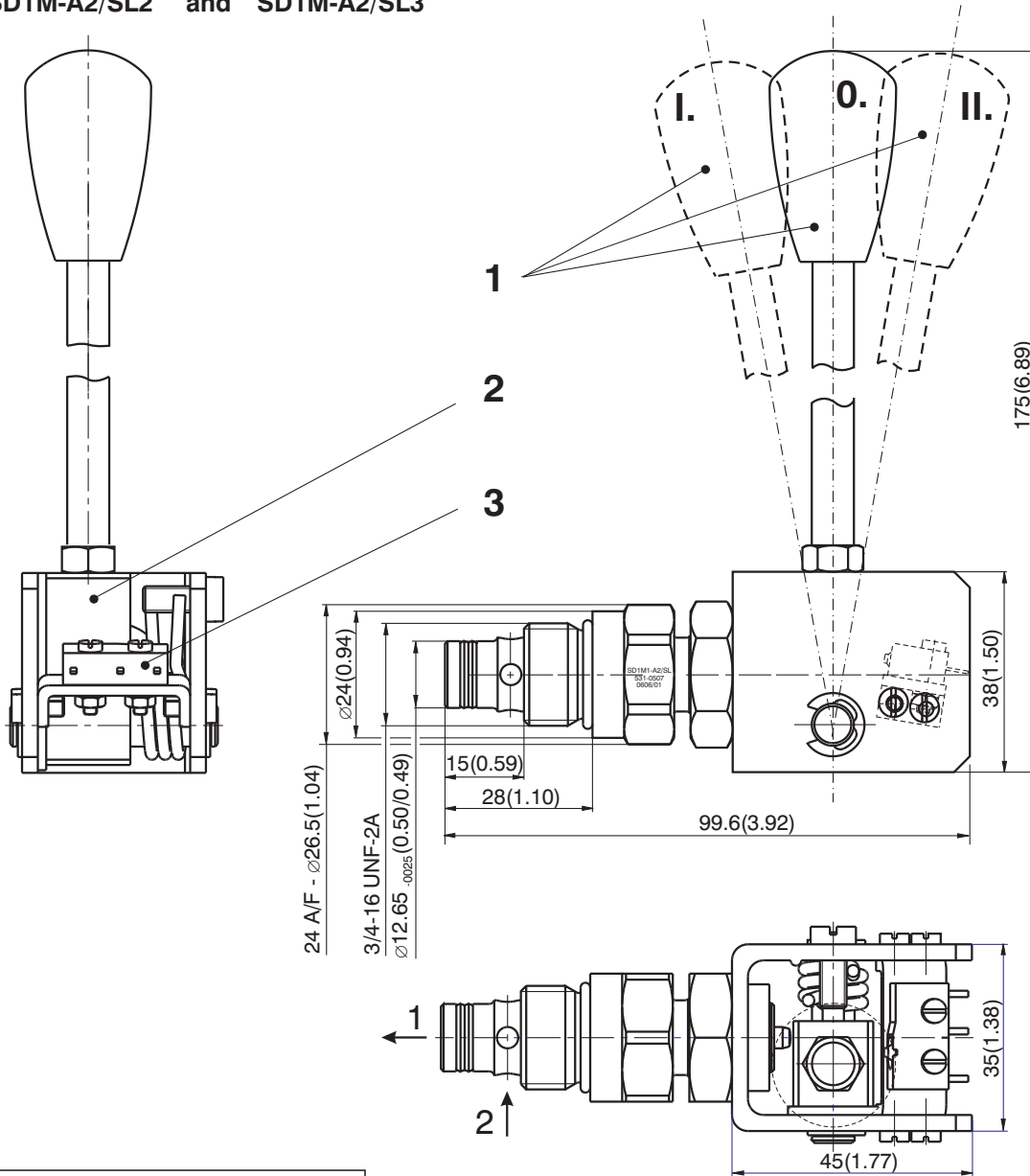

24 A/F - \varnothing 26.5(1.04)
 3/4-16 UNF-2A
 \varnothing 12.65_{-0.025}(0.50/0.49)

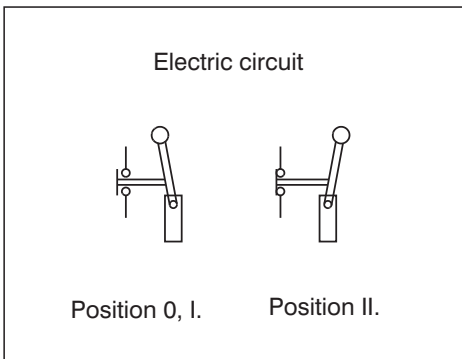

- 1 Hand lever
- 0 middle arrested position
- I. first position - opens the valve
- II. second position - closes the contact of the microswitch
- 2 Segment of the hand lever
- 3 Microswitch -only with SD1M-A2/SL3

Caution!

- The packing foil is recyclable.
- The technical information regarding the product presented in this catalogue is for descriptive purposes only. It should not be construed in any case as a guaranteed representation of the product properties in the sense of the law.

ARGO-HYTOS s.r.o. CZ - 543 15 Vrchlaví
 Tel.: +420-499-403111, Fax: +420-499-403421
 E-mail: sales.cz@argo-hytos.com
 www.argo-hytos.com

- 2/2 way cartridge valves solenoid operated with spool direction
- Manual override
- No spool sticking by too high tightening torque
- High transmitted power

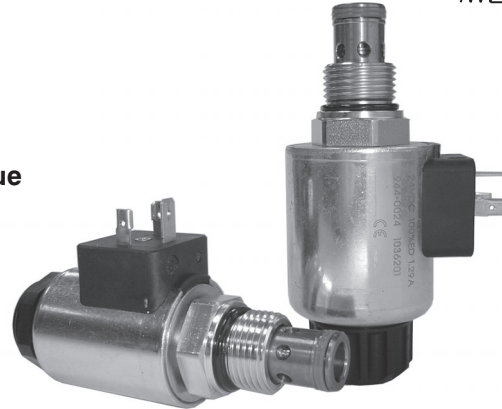
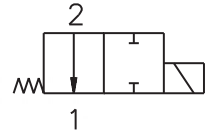

Functional Description

The directly operated 2/2 way solenoid actuated spool valve controls in the first line the start and stop function of the oil flow. The valve consists of the valve body (1), control spool (2), return spring (3), cartridge with actuating system (4) and of the solenoid coil (7) that is mounted on the actuating system. The valve bushing is screwed into the cartridge part (4).

The valve bushing is fixed in the cartridge by a wire ring (5) and sealed with the seal ring (6). Separation of the valve bushing and the cartridge prevent transmitting the stresses, which could be caused by too high tightening torques. The DC solenoid coils can be delivered for 12 V and 24 V supply voltages.

For the alternating current supply, either of 120V/60Hz or 230V/50Hz voltage, the relevant rectifiers for the C19 coil types are available in the auxiliary connector. For the C22 coil types and AC voltage design, the rectifiers are integrated directly into the connector base. By loosening the fixing nut (8), the solenoid coil can be replaced or turned in the range of 360°. The valve body is zinc coated.

Note:

The valves are supplied without solenoids coils. The solenoid coil, the terminal box and the housing body for line mounting have to be ordered separately.

Standard performance

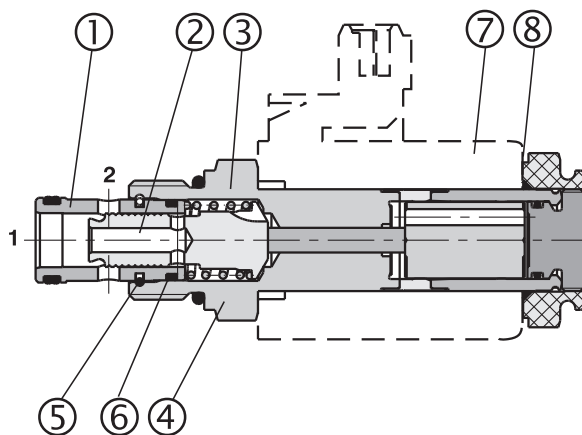

High performance

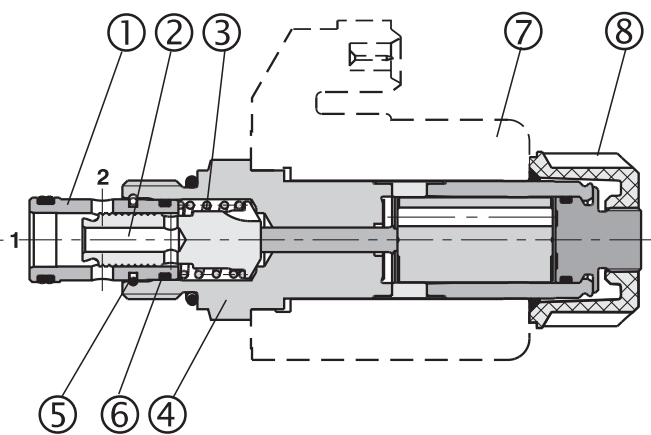

Ordering Code

SD2E-B2 /

**2/2 Way Solenoid Operated
Directional Control Valve Spool
7/8-14 UNF**

**No designation
V**

Seals
NBR
FPM (Viton)

Standard
High performance

**S
H**

**No designation
M2
M5
M9**

Manual override
standard
covered with rubber boot
socket head screw
without manual override

Description
Refer to the table with functional symbols

Solenoid coil, terminal box and body for line mounting have to be ordered separately. For selection of solenoid coil and terminal box type use catalogue HA 8007. For selection of valve body for in-line mounting use catalogue HA 0018.

Functional Symbols

Designation	Symbol	Interposition	Designation	Symbol	Interposition
2111			2112		

Manual Override

Dimensions in millimeters (inches)

No designation - standard

Designation M9 - without manual override

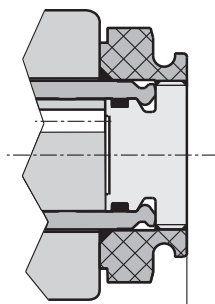
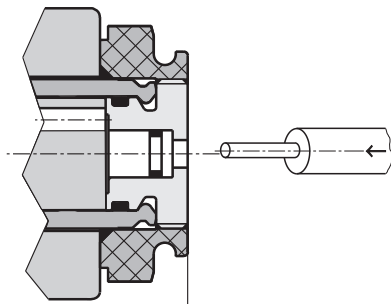

Standard valve ~70,5 (2.776)

Standard valve ~70,5 (2.776)

High performance valve ~83,0 (3.268)

High performance valve ~83,0 (3.268)

Designation M2 - covered with rubber boot

Designation M5 - with socket head screw 2.5 (0.098)

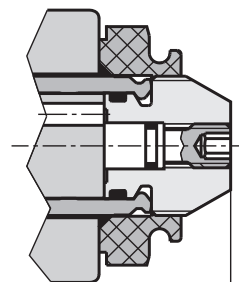
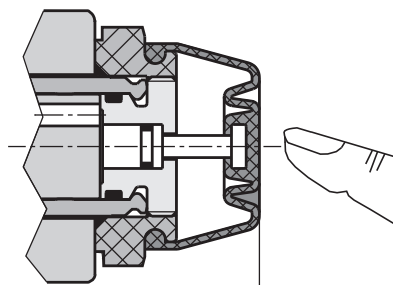

Standard valve ~82,0 (3.228)

Standard valve ~78,0 (3.071)

High performance valve ~100,0 (3.937)

High performance valve ~84,8 (3.339)

Technical Data

		Standard	High performance
Valve size		B2	
Cartridge cavity		7/8-14 UNF-2A	
Maximum flow	L/min (GPM)	50 (13.21)	60 (15.85)
Max. operating pressure	bar (PSI)	250 (3626)	350 (5076)
Pressure drop	bar (PSI)	see Δp -Q characteristics	
Hydraulic fluid		Hydraulic oils of power classes (HL, HLP) to DIN 51524	
Coil groups ¹⁾		C19B	C22B
Fluid temperature range	°C (°F)	-20 ... +80 (-4 ... +176)	-20 ... +80 (-4 ... +176)
Ambient temperature, max.	°C (°F)	-20 ... +50 (-4 .. +122)	-20 ... +80 (-4 ... +176)
Viscosity range	mm ² /s (SUS)	10 ... 500 (49 ... 2450)	
Maximum degree of fluid contamination		Class 21/18/15 according to ISO 4406	
Permissible rated voltage variation	%	AC,DC ±10	AC,DC ±15
Max. switching frequency	1/ h	15 000	
Duty cycle	%	100	
Enclosure type to EN 60529 ¹⁾		IP 67 (IP 65)	
Service life	cycles	10 ⁷	
Valve tightening torque	Nm (lbf.ft)	35+5 (25.81+3.68)	
Plastic nut tightening torque	Nm (lbf.ft)	3+1 (2.21+0.74)	3+1 (2.21+0.74)
Weight	kg(lbs)	0,22 (0.49)	0,29 (0.64)
Mounting position		unrestricted	
Valve body (data sheet HA 0018)		SB-B2	

¹⁾ see data sheet coils HA 8007

p-Q Characteristics

Measured at $v = 32 \text{ mm}^2/\text{s}$ (156 SUS)

Operating limits for hydraulic power transferred by the directional valve. For respective spool type - see functional symbols.

Standard valve

Oil 80 °C (176 °F) / Ambient temperature 50 °C (122 °F)
Voltage Un -10% [V], 24V

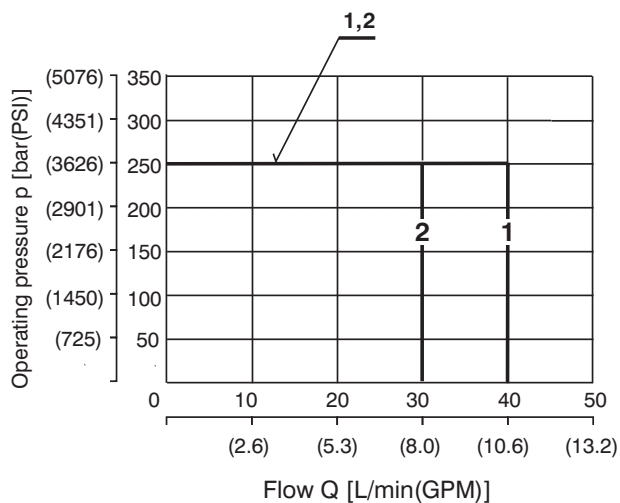

	Connection	Direction
1	2I11	2→1
2	2I12	2→1

High performance valve

Oil 80 °C (176 °F) / Ambient temperature 50 °C (122 °F)
Voltage Un -10% [V], 24V

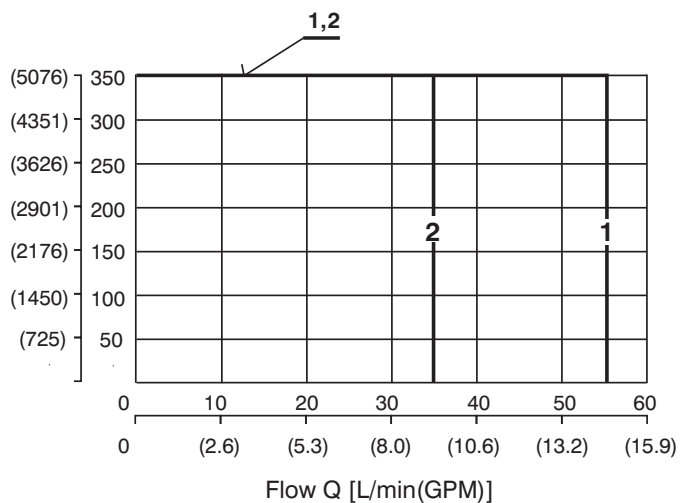

	Connection	Direction
1	2I11	2→1
2	2I12	2→1

Δp-Q Characteristics

Measured at $v = 32 \text{ mm}^2/\text{s}$ (156 SUS)

Pressure drops Δp related to flow rate

Standard valve + High performance valve

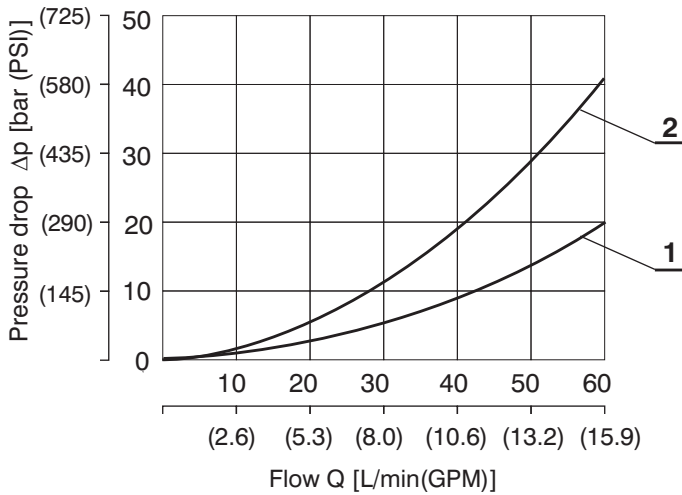

	Connection	Direction
1	2I11	1→2
1	2I11	2→1
2	2I12	1→2
2	2I12	2→1

Type of the Solenoid Coils

Dimensions in millimeters (inches)

Coil for Standard valve
C19B

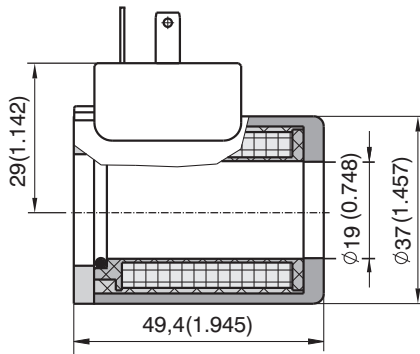

Coil for High performance valve
C22B

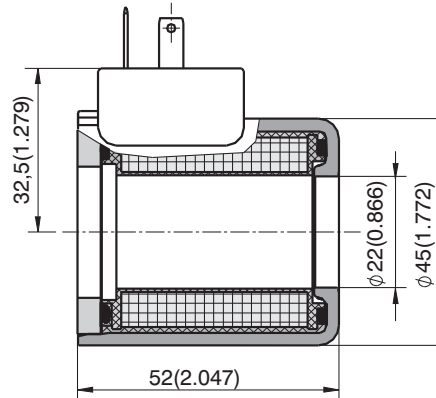

Note:

Example of most frequent coil types.

For complete range of SD2E-B2 valve coils with technical informatik about voltage, enclosure type, terminal box please refer to coil data sheet HA 8007.

Solenoid	Connector	Standard valve	High performance valve
		SD2E-B2 / S...	SD2E-B2 / H...
		Type code	Type code
12 VDC	EN 175301-803-A	C19B-01200E1-6NA	C22B-01200E1-6,55NA
24 VDC	EN 175301-803-A	C19B-02400E1-25,75NA	C22B-02400E1-25,3NA
12 VDC	AMP-Junior-Timer (2-pins)	C19B-01200E3-6NA	C22B-01200E3A-6,55NA
24 VDC	AMP-Junior-Timer (2-pins)	C19B-02400E3-25,75NA	C22B-02400E3A-25,3NA
12 VDC	Flying leads**	C19B-01200E8N300-6NA	C22B-01200E8N300-6,55NA
24 VDC	Flying leads**	C19B-02400E8N300-25,75NA	C22B-02400E8N300-25,3NA
12 VDC	Deutsch DT04-2P	---	C22B-01200E12-6,55NA
24 VDC	Deutsch DT04-2P	---	C22B-02400E12-25,3NA
120 VAC	EN 175301-803-A	C19B-10600E1-494NA*	C22B-10600E1-545NA*
230 VAC	EN 175301-803-A	C19B-20500E1-1653NA*	C22B-20500E1-2353NA*
120 VAC	EN 175301-803-A (with rectifier)	C19B-12060E5-494NA	C22B-12060E5-545NA
230 VAC	EN 175301-803-A (with rectifier)	C19B-23050E5-1653NA	C22B-23050E5-2353NA

*Use the terminal box with rectifier!

**Standard length of connecting wire is 300 mm, other lengths on request.

Valve Dimensions

Dimensions in millimeters (inches)

Standard valve

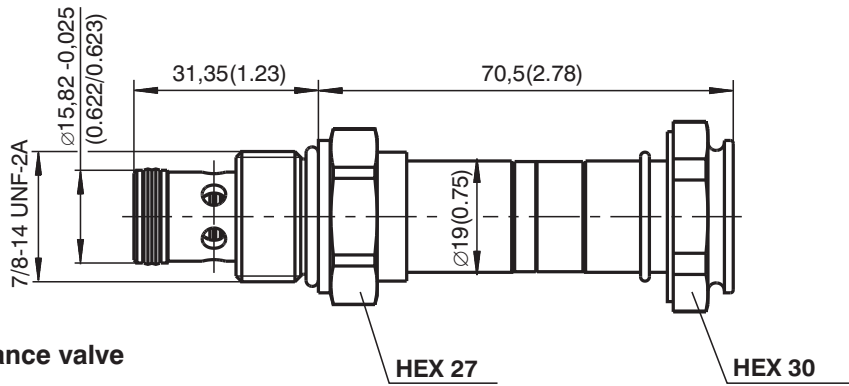

High performance valve

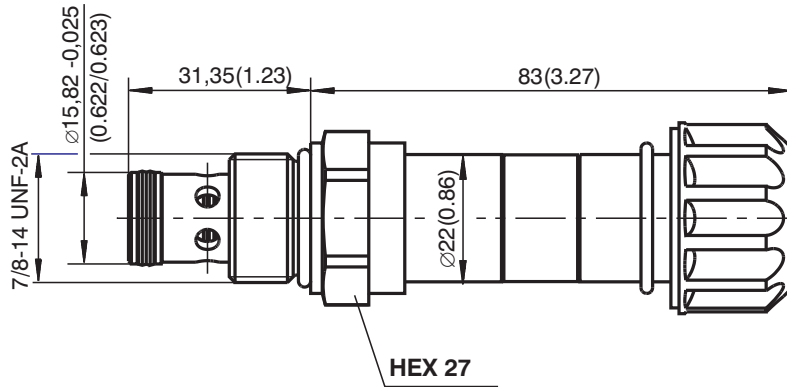

Cavity

Dimensions in millimeters (inches)

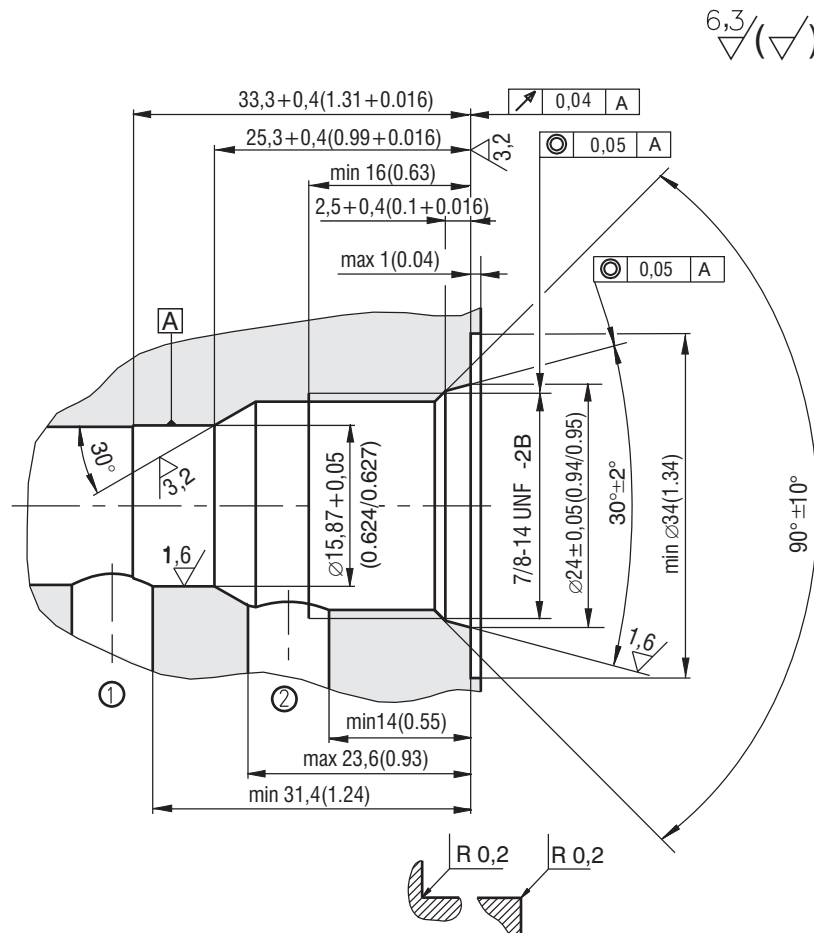

Spare Parts

Dimensions in millimeters

Standard and high performance valve

Dualseal - PU	O-ring - NBR	O-ring - Viton	Ordering number
13,47 x 15,87 x 3,1 (1pc.)	19,4 x 2,1 (1pc.)	-	18960400
13,47 x 15,87 x 3,1 (1pc.)	-	19,4 x 2,1 (1pc.)	18960500

Solenoid retaining nut with seal for standard valve

Type of nut	O-ring - Viton	Ordering number
Standard nut	18 x1,5 (1pc.)	20777000
Nut M2	18 x1,5 (1pc.)	20777600

Solenoid retaining nut with seal for high performance valve

Type of nut	O-ring - Viton	Ordering number
Standard nut	22 x 2 (1pc.)	15844600
Nut M2	22 x 2 (1pc.)	18961700

Caution!

- The packing foil is recyclable.
- The technical information regarding the product presented in this catalogue is for descriptive purposes only. It should not be construed in any case as a guaranteed representation of the product properties in the sense of the law.

ARGO-HYTOS s.r.o. CZ - 543 15 Vrchlabí
 Tel.: +420-499-403 111
 E-mail: info.cz@argo-hytos.com
 www.argo-hytos.com

- 3/2 way cartridge valves solenoid operated with spool direction
- Manual override
- No spool sticking by too high tightening torque
- High transmitted power

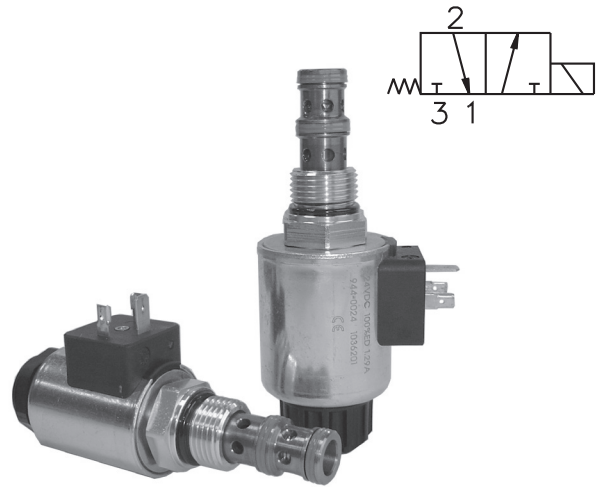

Functional Description

The directly operated 3/2 way solenoid actuated spool valve controls in the first line the start and stop function of the oil flow. The valve consists of the valve body (1), control spool (2), return spring (3), cartridge with actuating system (4) and of the solenoid coil (7) that is mounted on the actuating system. The valve bushing is screwed into the cartridge part (4).

The valve bushing is fixed in the cartridge by means of the wire ring (5) and sealed with the seal ring (6). Separation of the valve bushing and the cartridge prevent transmitting the stresses, which could be caused by too high tightening torques. The DC solenoid coils can be delivered for 12 V and 24 V supply voltages.

For the alternating current supply, either of 120V/60Hz or 230V/50Hz voltage, the relevant rectifiers for the C19 coil types are available in the auxiliary connector. For the C22 coil types and AC voltage design, the rectifiers are integrated directly into the connector base. . By loosening the fixing nut (8), the solenoid coil can be replaced or turned in the range of 360°. The valve body is zinc coated.

Note:

The valves are supplied without solenoids coils. The solenoid coil, the terminal box and the housing body for pipeline mounting have to be ordered separately.

Standard performance

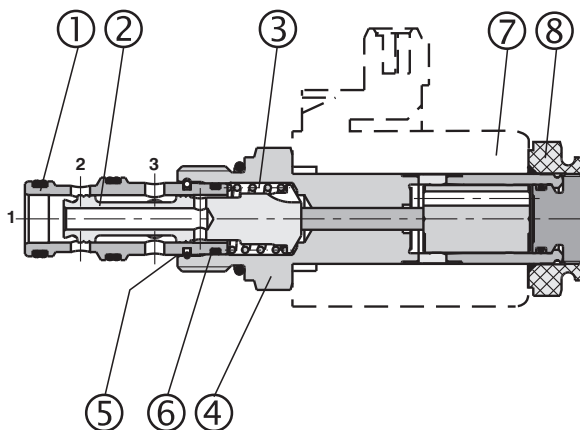

High performance

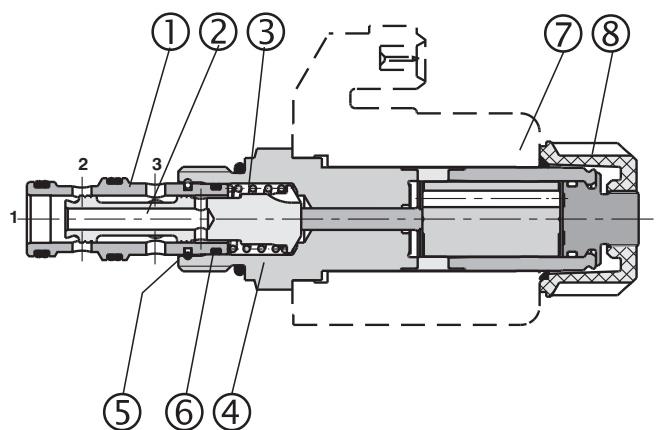

Ordering Code

SD2E-B3 /

**3/2 Way Solenoid Operated
Directional Control Valve Spool
7/8-14 UNF**

No designation
V

Seals
NBR
FPM (Viton)

Standard
High performance

S
H

No designation
M2
M5
M9

Manual override
standard
covered with rubber boot
socket head screw
without manual override

Description
Refer to the table with functional symbols

Solenoid coil, terminal box and body for line mounting have to be ordered separately. For selection of solenoid coil and terminal box type use catalogue HA 8007. For selection of valve body for in-line mounting use catalogue HA0018.

Functional Symbols

Designation	Symbol	Interposition	Designation	Symbol	Interposition
2D21			2D26		
2D25					

Manual Override

Dimensions in millimeters (inches)

No designation - standard

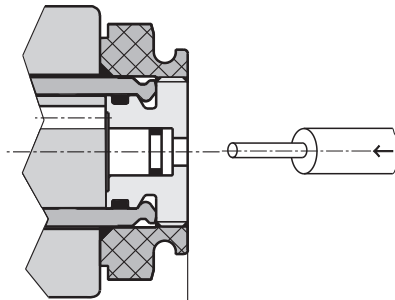

Standard valve ~70,5 (2.776)

High performance valve ~83,0 (3.268)

Designation **M9** - without manual override

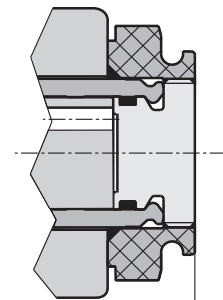

Standard valve ~70,5 (2.776)

High performance valve ~83,0 (3.268)

Designation **M2** - covered with rubber boot

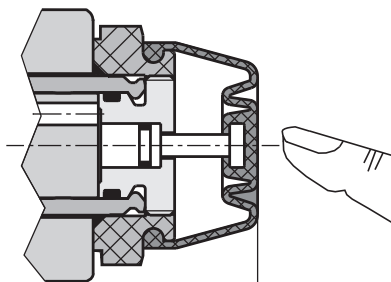

Standard valve ~82,0(3.228)

High performance valve ~100,0(3.937)

Designation **M5** - with socket head screw 2.5 (0.098)

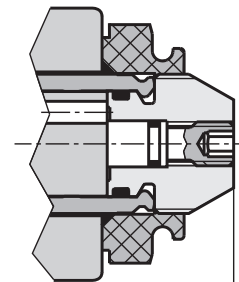

Standard valve ~78,0(3.071)

High performance valve ~84,8(3.339)

Technical Data

		Standard	High performance
Valve size		B3	
Cartridge cavity		7/8-14 UNF-2A	
Maximum flow	L/min (GPM)	50 (13.2)	60 (15.8)
Max. operating pressure	bar (PSI)	250 (3626)	350 (5076)
Pressure drop	bar (PSI)	see Δp -Q characteristics	
Hydraulic fluid		Hydraulic oils of power classes (HL, HLP) to DIN 51524	
Coil groups ¹⁾		C19B	C22B
Fluid temperature range	°C (°F)	-20 ... +80 (-4 ... +176)	-20 ... +80 (-4 ... +176)
Ambient temperature, max.	°C (°F)	-20 ... +50 (-4 ... +122)	-20 ... +80 (-4 ... +176)
Viscosity range	mm ² /s (SUS)	10 ... 500 (49 ... 2450)	
Maximum degree of fluid contamination		Class 21/18/15 according to ISO 4406	
Permissible rated voltage variation	%	AC, DC ±10	AC, DC ±15
Max. switching frequency	1/ h	15 000	
Duty cycle	%	100	
Enclosure type to EN 60529 ¹⁾		IP 67 (IP 65)	
Service life	cycles	10 ⁷	
Valve tightening torque	Nm (lbf.ft)	35+5 (25.81+3.68)	
Plastic nut tightening torque	Nm (lbf.ft)	3+1 (2.213+0.738)	3+1 (2.21+0.738)
Weight	kg (lbs)	0,24 (0.53)	0,31 (0.68)
Mounting position		unrestricted	
Valve body (data sheet HA 0018)		SB-B3	

¹⁾ see data sheet coils HA 8007

p-Q Characteristics

Measured at $\nu = 32 \text{ mm}^2/\text{s}$ (156 SUS)

Operating limits for hydraulic power transferred by the directional valve. For respective spool type - see functional symbols.

Standard valve

Oil 80 °C (176 °F) / Ambient temperature 50 °C (122 °F)
Voltage Un -10% [V], 24V

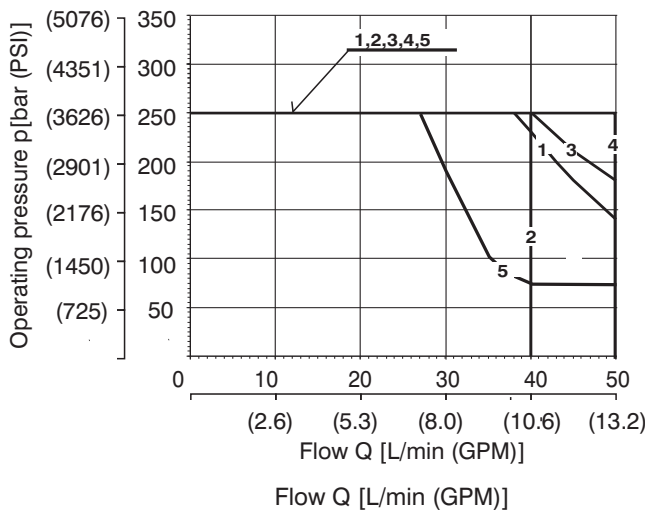

	Connection	Direction
1	2D21	3→2
2	2D21	2→1
3	2D25	3→2
4	2D25	2→1
5	2D26	3→2
2	2D26	2→1

High performance valve

Oil 80 °C (176 °F) / Ambient temperature 50 °C (122 °F)
Voltage Un -10% [V], 24V

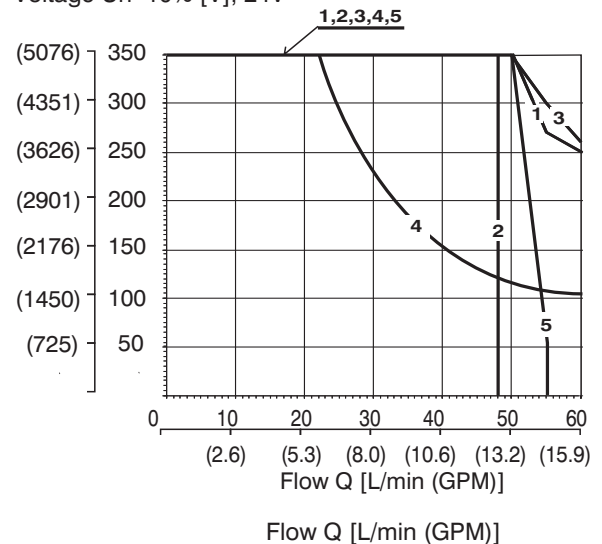

	Connection	Direction
1	2D21	3→2
2	2D21	2→1
3	2D25	3→2
5	2D25	2→1
4	2D26	3→2
5	2D26	2→1

Δp-Q Characteristics

Measured at $v = 32 \text{ mm}^2/\text{s}$ (156 SUS)

Pressure drops Δp related to flow rate

Standard valve + High performance valve

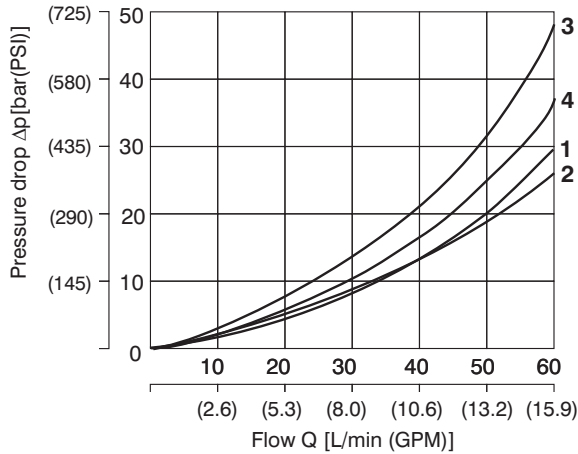

	Connection	Direction
1	2D21	2→1
1	2D21	3→2
3	2D25	3→2
4	2D25	2→1
1	2D26	3→2
1	2D26	2→1

Type of the Solenoid Coils

Dimensions in millimeters (inches)

Coil for Standard valve
C19B

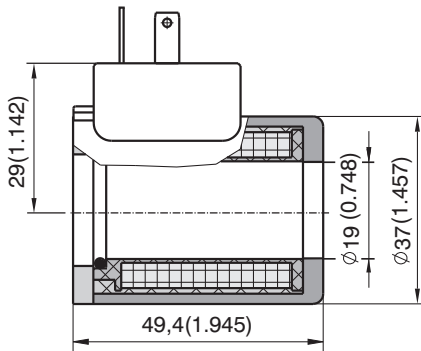

Coil for High performance valve
C22B

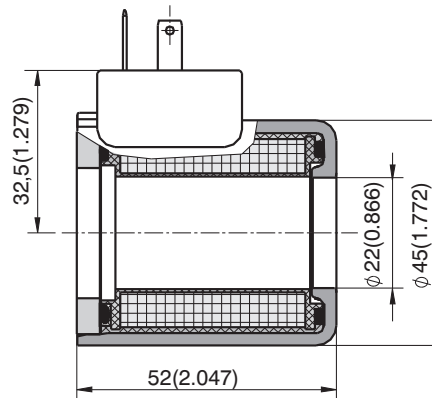

Note:

Example of most frequent coil types.

For complete range of SD2E-B3 valve coils with technical informatik about voltage, enclosure type, terminal box please refer to coil data sheet HA 8007.

Solenoid	Connector	Standard valve	High performance valve
		SD2E-B3 / S...	SD2E-B3 / H...
		Type code	Type code
12 VDC	EN 175301-803-A	C19B-01200E1-6NA	C22B-01200E1-6,55NA
24 VDC	EN 175301-803-A	C19B-02400E1-25,75NA	C22B-02400E1-25,3NA
12 VDC	AMP-Junior-Timer (2-pins)	C19B-01200E3-6NA	C22B-01200E3A-6,55NA
24 VDC	AMP-Junior-Timer (2-pins)	C19B-02400E3-25,75NA	C22B-02400E3A-25,3NA
12 VDC	Flying leads**	C19B-01200E8N300-6NA	C22B-01200E8N300-6,55NA
24 VDC	Flying leads**	C19B-02400E8N300-25,75NA	C22B-02400E8N300-25,3NA
12 VDC	Deutsch DT04-2P	---	C22B-01200E12-6,55NA
24 VDC	Deutsch DT04-2P	---	C22B-02400E12-25,3NA
120 VAC	EN 175301-803-A	C19B-10600E1-494NA*	C22B-10600E1-545NA*
230 VAC	EN 175301-803-A	C19B-20500E1-1653NA*	C22B-20500E1-2353NA*
120 VAC	EN 175301-803-A (with rectifier)	C19B-12060E5-494NA	C22B-12060E5-545NA
230 VAC	EN 175301-803-A (with rectifier)	C19B-23050E5-1653NA	C22B-23050E5-2353NA

*Use the terminal box with rectifier!

**Standard length of connecting wire is 300 mm, other lengths on request.

Valve Dimensions

Dimensions in millimeters (inches)

Standard valve

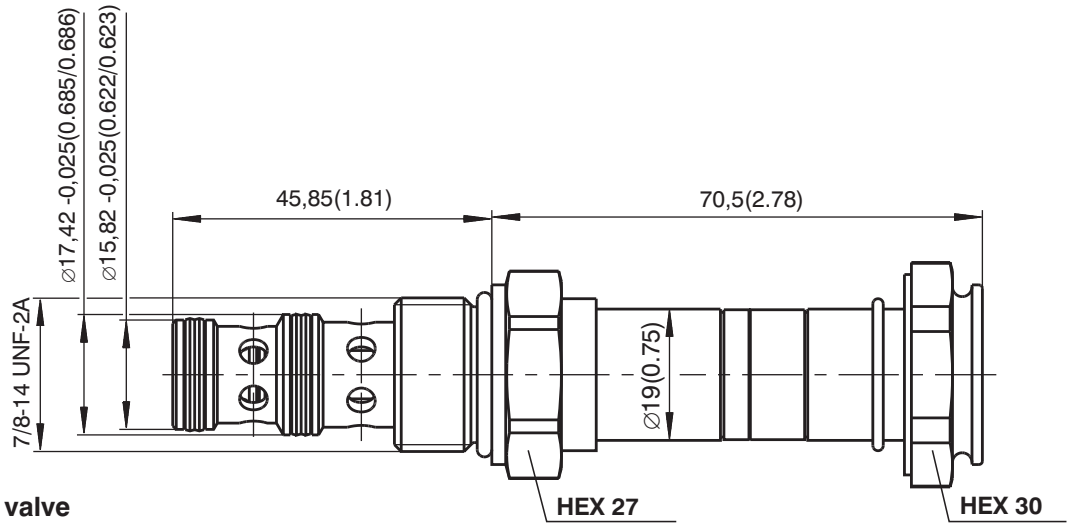

High performance valve

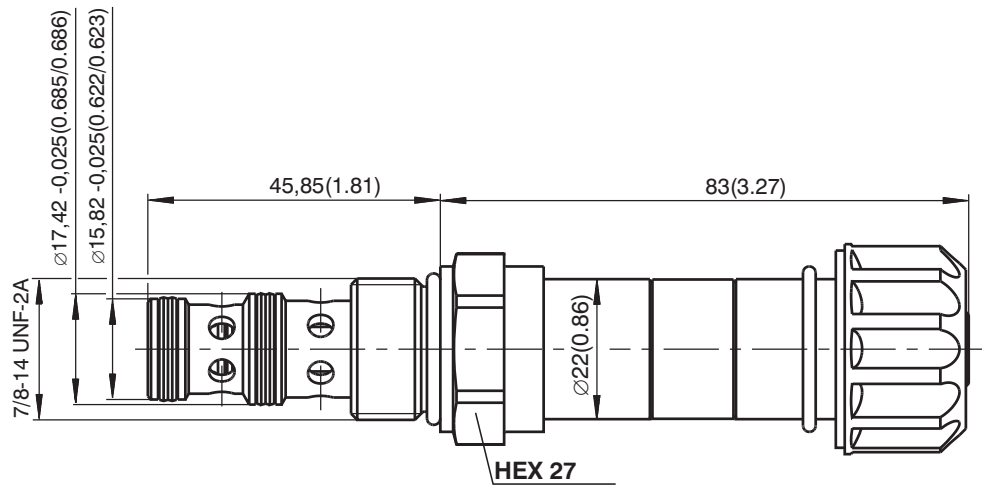

Cavity

Dimensions in millimeters (inches)

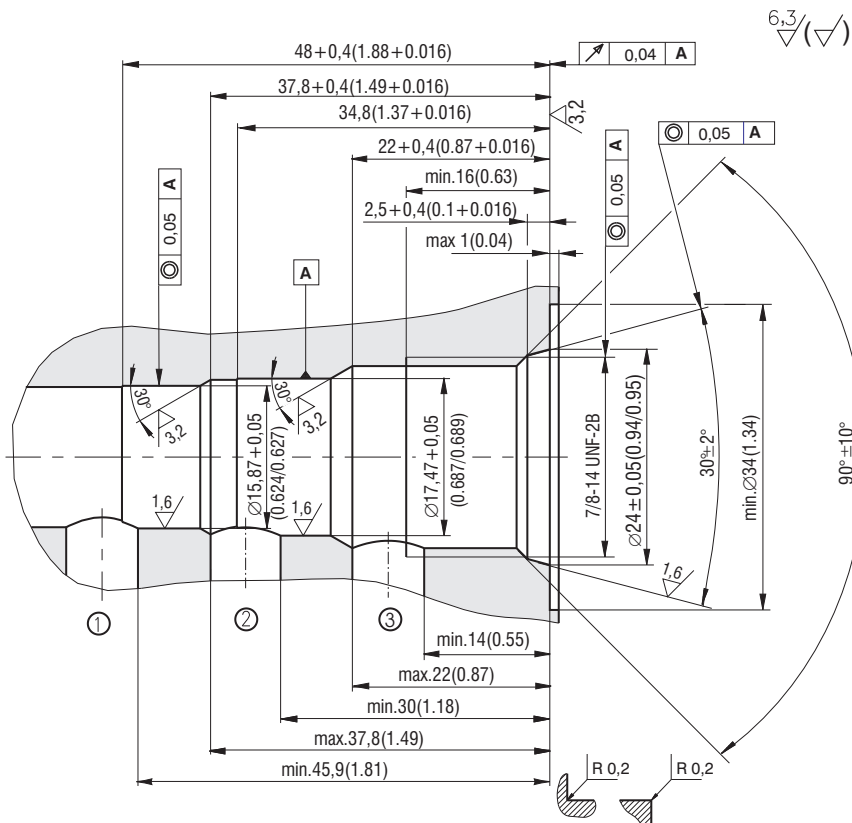

Spare Parts

Dimensions in millimeters (inches)

Standard and high performance valve

Dualseal - PU	O-ring - NBR	O-ring - Viton	Ordering number
13,47 x 15,87 x 3,1 (1pc.)	19,4 x 2,1 ((1pc.)	-	18960700
17,47 x 15,07 x 3,1 (1pc.)			
13,47 x 15,87 x 3,1 (1pc.)	-	19,4 x 2,1 (1pc.)	18960600
17,47 x 15,07 x 3,1 (1pc.)			

Solenoid retaining nut with seal for standard valve

Type of nut	O-ring - Viton	Ordering number
Standard nut	18 x 1,5 (1pc.)	20777000
Nut M2	18 x 1,5 (1pc.)	20777600

Solenoid retaining nut with seal for high performance valve

Type of nut	O-ring - Viton	Ordering number
Standard nut	22 x 2 (1pc.)	15844600
Nut M2	22 x 2 (1pc.)	18961700

Caution!

- The packing foil is recyclable.
- The technical information regarding the product presented in this catalogue is for descriptive purposes only. It should not be construed in any case as a guaranteed representation of the product properties in the sense of the law.

ARGO-HYTOS s.r.o. CZ - 543 15 Vrchlaví
 Tel.: +420-499-403 111
 E-mail: info.cz@argo-hytos.com
 www.argo-hytos.com

- 4/2 way cartridge valves solenoid operated with spool direction
- Manual override
- No spool sticking by too high tightening torque
- High transmitted power

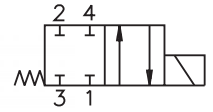
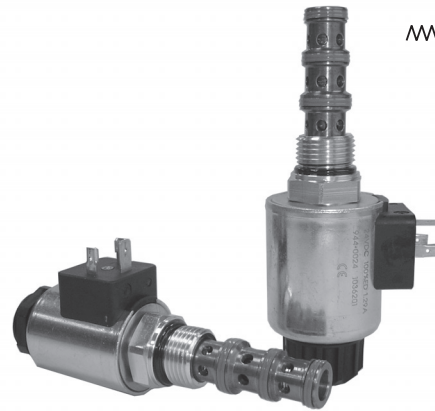

Functional Description

The directly operated 4/2 way solenoid actuated spool valve controls in the first line the start and stop function of the oil flow. The valve consists of the valve body (1), control spool (2), return spring (3), cartridge with actuating system (4) and of the solenoid coil (7) that is mounted on the actuating system. The valve bushing is screwed into the cartridge part.

The valve bushing is fixed in the cartridge by a wire ring (5) and sealed with the seal ring (6). Separation of the valve bushing and the cartridge prevent transmitting the stresses, which could be caused by too high tightening torques. The DC solenoid coils can be delivered for 12 V and 24 V supply voltages.

For the alternating current supply, either of 120V/60Hz or 230V/50Hz voltage, the relevant rectifiers for the C19 coil types are available in the auxiliary connector. For the C22 coil types and AC voltage design, the rectifiers are integrated directly into the connector base. By loosening the fixing nut (8), the solenoid coil can be replaced or turned in the range of 180°. The valve body is zinc coated.

Note:

The valves are supplied without solenoids coils. The solenoid coil, the terminal box and the housing body for line mounting have to be ordered separately.

Standard performance

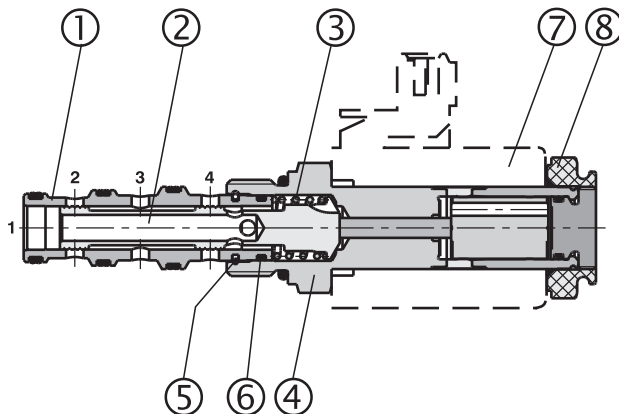

High performance

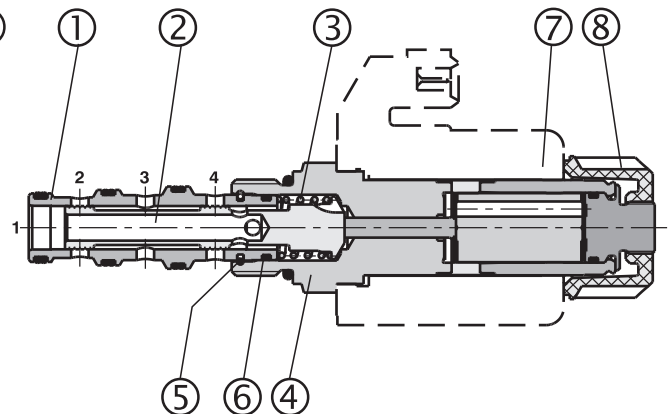

Ordering Code

SD2E-B4 /

**4/2 Way Solenoid Operated
Directional Control Valve
7/8-14 UNF**

Standard
High Performance

Description
Refer to the table with functional symbols

S
H

No designation
V

Seals
NBR
FPM (Viton)

No designation
M2
M5
M9

Manual override
standard
covered with rubber boot
socket head screw
without manual override

Solenoid coil, terminal box and body for line mounting have to be ordered separately. For selection of solenoid coil and terminal box type use catalogue HA 8007. For selection of valve body for in-line mounting use catalogue HA0018.

Functional Symbols

Designation	Symbol	Interposition	Designation	Symbol	Interposition
2Z11			2X21		
2Z51					

Manual Override

No designation - standard

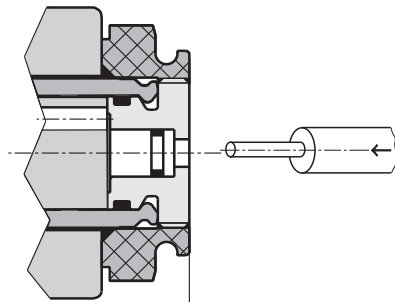

Standard valve ~70,5 (2.776)
High performance valve ~83,0 (3.268)

Designation **M9** - without manual override

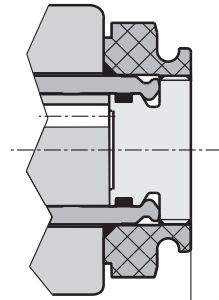

Standard valve ~70,5 (2.776)
High performance valve ~83,0 (3.268)

Designation **M2** - covered with rubber boot

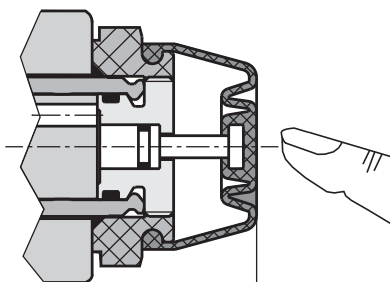

Standard valve ~82,0(3.228)
High performance valve ~100,0(3.937)

Designation **M5** - with socket head screw 2.5 (0.098)

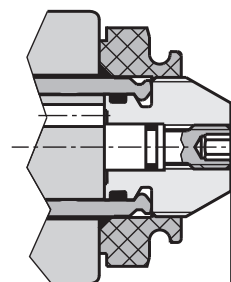

Standard valve ~78,0(3.071)
High performance valve ~84,8(3.339)

Technical Data

		Standard	High performance
Valve size		B4	
Cartridge cavity		7/8-14 UNF-2A	
Maximum flow	L/min (GPM)	50 (13.21)	60 (15.85)
Max. operating pressure	bar (PSI)	250 (3625)	350 (5076)
Pressure drop	bar (PSI)	see Δp -Q characteristics	
Hydraulic fluid		Hydraulic oils of power classes (HL, HLP) to DIN 51524	
Coil groups ¹⁾		C19B	C22B
Fluid temperature range	°C (°F)	-20 ... +80 (-4... +176)	-20 ... +80 (-4 ... +176)
Ambient temperature, max.	°C (°F)	-20 ... +50 (-4 ...+122)	-20 ... +80 (-4 ... +176)
Viscosity range	mm ² /s (SUS)	10 ... 500 (49 ... 2450)	
Maximum degree of fluid contamination		Class 21/18/15 according to ISO 4406	
Permissible rated voltage variation	%	AC,DC ±10	AC,DC ±15
Max. switching frequency	1/h	15 000	
Duty cycle	%	100	
Enclosure type to EN 60529 ¹⁾		IP 65	
Service life	cycles	10 ⁷	
Valve tightening torque	Nm (lbf.ft)	35+5 (25.81+3.68)	
Plastic nut tightening torque	Nm (lbf.ft)	3+1 (2.213+0.738)	3+1 (2.21+0.738)
Weight	kg (lbs)	0,25 (0.55)	0,32 (0.71)
Mounting position		unrestricted	
Valve body (data sheet HA 0018)		SB-B4	

¹⁾ see data sheet coils HA 8007

p-Q Characteristics

Measured at $v = 32 \text{ mm}^2/\text{s}$ (156 SUS)

Operating limits for maximum hydraulic power transferred by the directional valve. For respective spool type - see functional symbols.

Standard valve

Oil 80 °C (176 °F) / Ambient temperature 50 °C (122 °F)
Voltage Un -10% [V], 24V

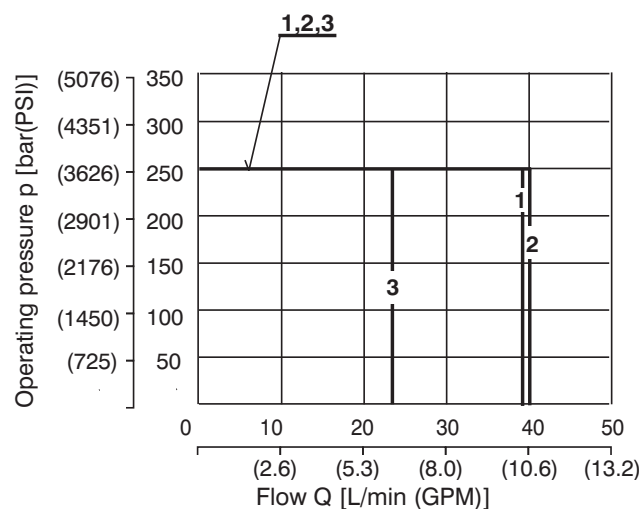

	Connection	Direction
1	2Z11	3-2 → 4-1
2	2Z51	3-4 → 2-1
2	2X21	3-4 → 2-1
3	2X21	3-2 → 4-1

High performance valve

Oil 80 °C (176 °F) / Ambient temperature 50 °C (122 °F)
Voltage Un -10% [V], 24V

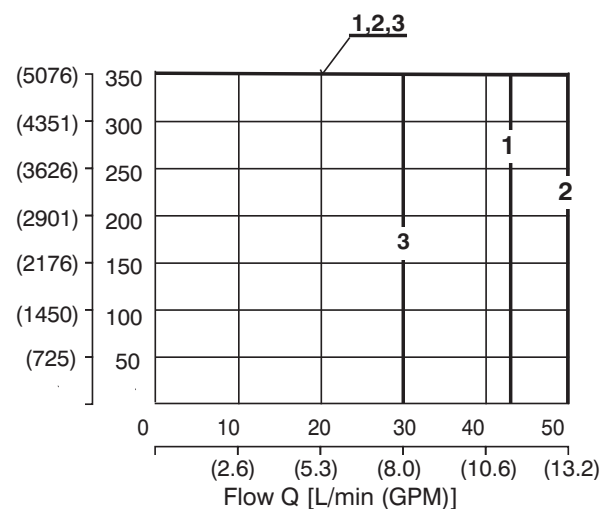

	Connection	Direction
1	2Z11	3-2 → 4-1
2	2Z51	3-4 → 2-1
3	2X21	3-2 → 4-1
2	2X21	3-4 → 2-1

Δp-Q Characteristics

Measured at $v = 32 \text{ mm}^2/\text{s}$ (156 SUS)

Pressure drops Δp related to flow rate.

Standard valve + High performance valve

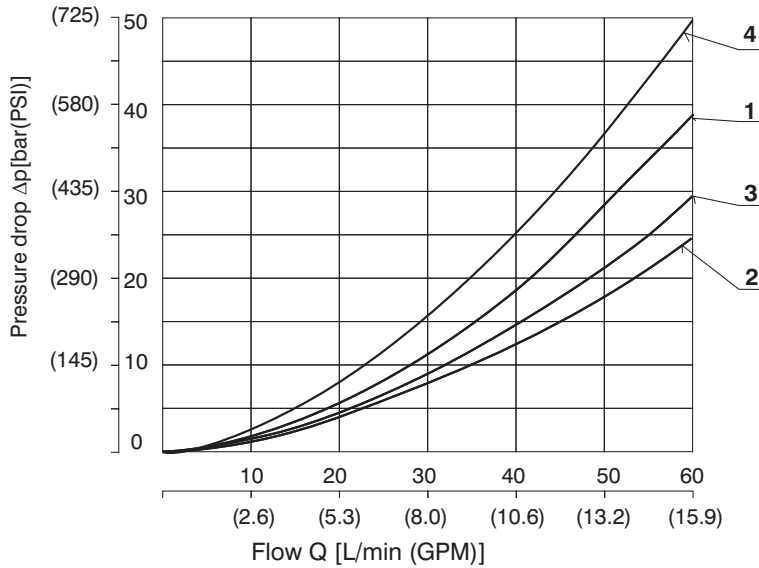

	Connection	Direction
1	2Z11	3→2
1	2Z11	4→1
3	S2Z51	3→4
3	S2Z51	2→1
2	H2Z51	3→4
3	H2Z51	2→1
3	2X21	3→2
4	2X21	4→1
3	2X21 Qmax 50 l/min	3→4
2	2X21 Qmax 40 l/min	2→1

Type of the Solenoid Coils

Dimensions in millimeters (inches)

Coil for Standard valve
C19B

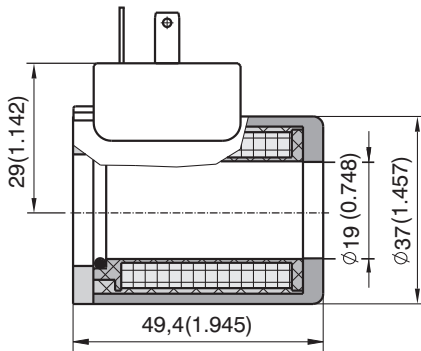

Coil for High performance valve
C22B

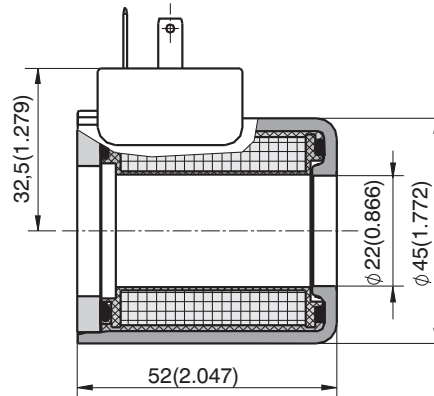

Note:

Example of most frequent coil types.

For complete range of SD2E-B4 valve coils with technical informatik about voltage, enclosure type, terminal box please refer to coil data sheet HA 8007.

Voltage	Connector	Standard	High performance
		SD2E-B4 / S...	SD2E-B4 / H...
		Type code	Type code
12 VDC	EN 175301-803-A	C19B-01200E1-6NA	C22B-01200E1-6,55NA
24 VDC	EN 175301-803-A	C19B-02400E1-25,75NA	C22B-02400E1-25,3NA
12 VDC	AMP-Junior-Timer	C19B-01200E3-6NA	C22B-01200E3A-6,55NA
24 VDC	AMP-Junior-Timer	C19B-02400E3-25,75NA	C22B-02400E3A-25,3NA
12 VDC	free cables**	C19B-01200E8N300-6NA	C22B-01200E8N300-6,55NA
24 VDC	free cables**	C19B-02400E8N300-25,75NA	C22B-02400E8N300-25,3NA
12 VDC	Deutsch DT04-2P	---	C22B-01200E12-6,55NA
24 VDC	Deutsch DT04-2P	---	C22B-02400E12-25,3NA
120 VAC	EN 175301-803-A	C19B-10600E1-494NA*	C22B-10600E1-545NA*
230 VAC	EN 175301-803-A	C19B-20500E1-1653NA*	C22B-20500E1-2353NA*
120 VAC	EN 175301-803-A (with rectifier)	C19B-12060E5-494NA	C22B-12060E5-545NA
230 VAC	EN 175301-803-A (with rectifier)	C19B-23050E5-1653NA	C22B-23050E5-2353NA

*Use the terminal box with rectifier!

**Standard length of connecting wire is 300 mm, other lengths on request.

Valve Dimensions

Dimensions in millimeters (inches)

Standard valve

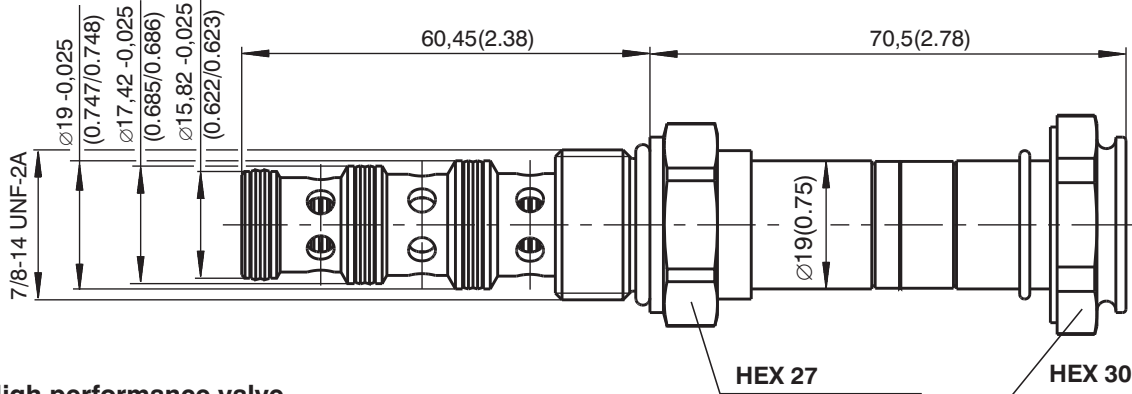

High performance valve

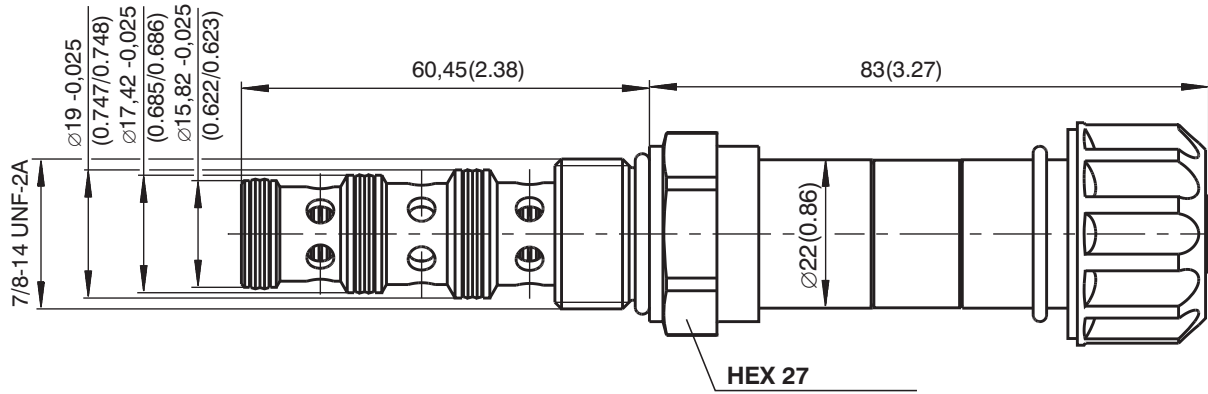

Cavity

Dimensions in millimeters (inches)

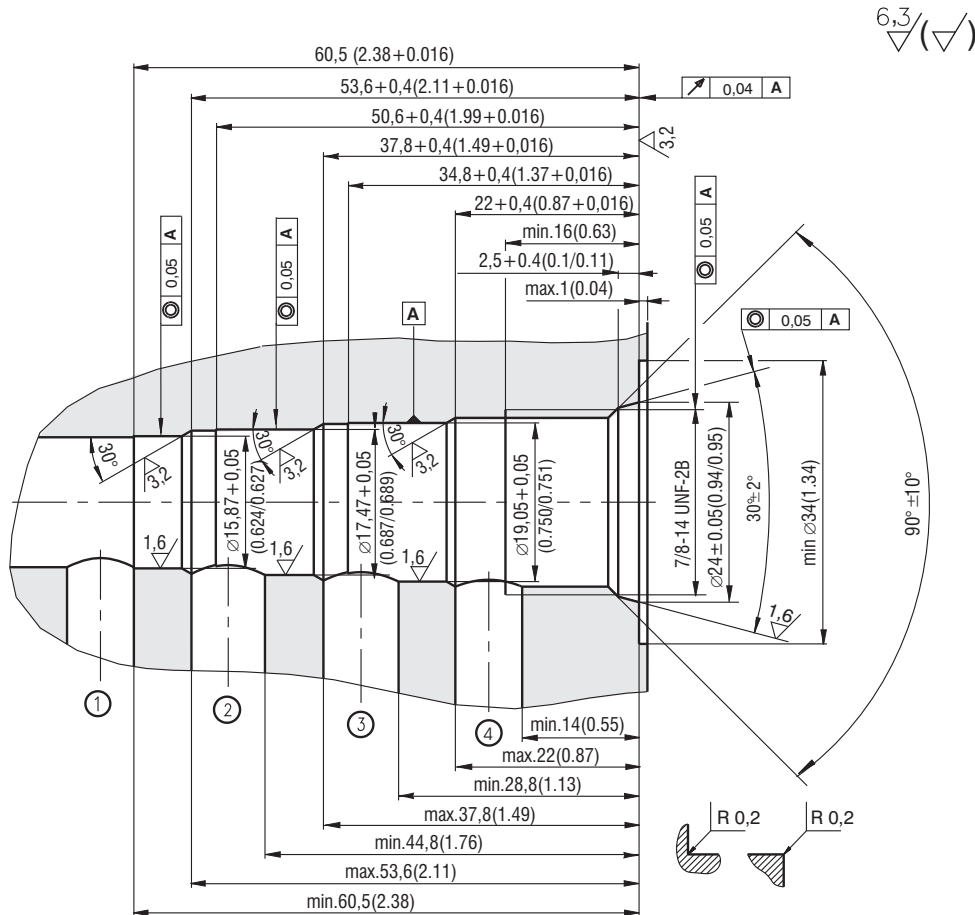

Spare Parts

Dimensions in millimeters

Standard and high performance valve

Dualseal - PU	O-ring - NBR	O-ring - Viton	Ordering number
13,47 x 15,87 x 3,1 (1pc.)	19,4 x 2,1 (1pc.)	-	18960800
17,47 x 15,07 x 3,1 (1pc.)			
19,05 x 16,65 x 3,1 (1pc.)			
13,47 x 15,87 x 3,1 (1pc.)	-	19,4 x 2,1 (1pc.)	18960900
17,47 x 15,07 x 3,1 (1pc.)			
19,05 x 16,65 x 3,1 (1pc.)			

Solenoid retaining nut with seal for standard valve

Type of nut	O-ring - Viton	Ordering number
Standard nut	18 x 1,5 (1pc.)	20777000
Nut M2	18 x 1,5 (1pc.)	20777600

Solenoid retaining nut with seal for high performance valve

Type of nut	O-ring - Viton	Ordering number
Standard nut	22 x 2 (1pc.)	15844600
Nut M2	22 x 2 (1pc.)	18961700

Caution!

- The packing foil is recyclable.
- The technical information regarding the product presented in this catalogue is for descriptive purposes only. It should not be construed in any case as a guaranteed representation of the product properties in the sense of the law.

ARGO-HYTOS s.r.o. CZ - 543 15 Vrchlabí
 Tel.: +420-499-403 111
 E-mail: info.cz@argo-hytos.com
 www.argo-hytos.com

- 2/2 way cartridge valves solenoid operated with spool direction
- Manual override
- High transmitted power

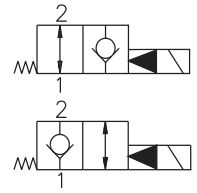
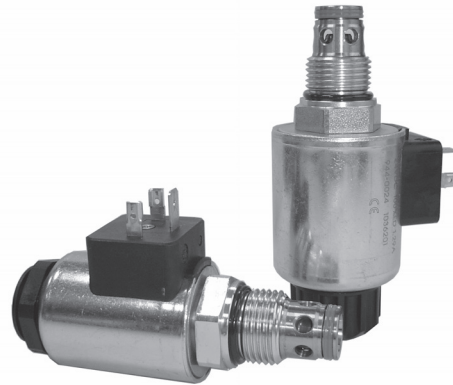

Functional Description

The pilot operated 2/2 way solenoid actuated poppet valves control in the first line the start and stop function of the oil flow. The valve consists of the valve bushing (1), main control spool (2), return spring (3), cartridge with actuating system (4) and of the solenoid coil (5) that is mounted on the actuating system. The valve bushing is screwed into the cartridge part.

In the variant normally closed / normally open, the valve is securely held in the respective basic position by a spring. By energizing the solenoid coil the spring force is overcome and the pilot valve is pressed onto the seat or lifted. Opening and closing of the main control spool is hydraulically supported through the orifice boring created in the main control spool.

The DC solenoid coils can be delivered for 12 V and 24 V supply voltages.

For the alternating current supply, either of 120V/60Hz or 230V/50Hz voltage, the relevant rectifiers for the C19 coil types are available in the auxiliary connector. For the C22 coil types and AC voltage design, the rectifiers are integrated directly into the connector base. By loosening the fixing nut (6), the solenoid coil can be replaced or turned in the range of 360°.

Notice.

The valves are supplied without solenoids coils. The solenoid coil, the terminal box and the body for line mounting have to be ordered separately.

Absence of current opened 2O2

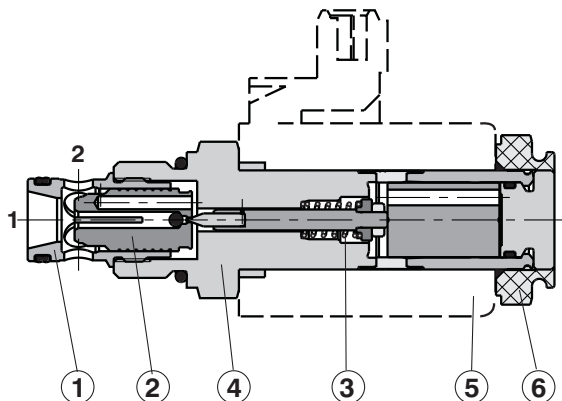

Absence of current closed 2L2

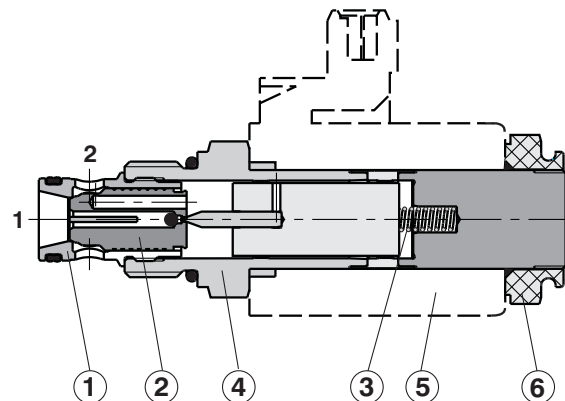

Ordering Code

SD3E-B2 /



**2/2 Way Solenoid Operated
Directional Control Valve
Poppet Type 7/8-14 UNF**

No designation
V

Seals
NBR
FPM (Viton)

Standard
High Performance

S
H

No designation
M2
M5
M9

Manual override
standard for 202
covered with rubber bootn only for 202
socket head screw
without manual override

Description
Refer to the table with functional symbols

Solenoid coil, terminal box and body for line mounting have to be ordered separately. For selection of solenoid coil and terminal box type use catalogue HA 8007. For selection of valve body for in-line mounting use catalogue HA0018.

Functional Symbols

Designation	Symbol	Designation	Symbol
202		2L2	

Manual Override

Dimensions in millimeters (inches)

No designation - Standard for 202

Designation **M9** - for 2L2
without manual override

Designation **M9** - for 202
without manual override

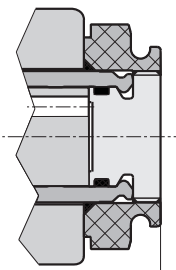
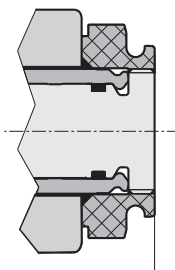
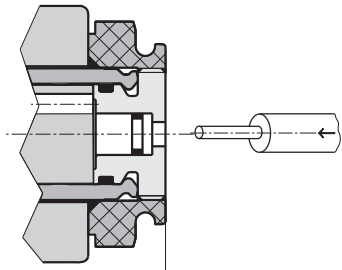

Standard valve ~70,5 (2.776)
High performance valve ~83,0 (3.268)

Standard valve ~71,0 (2.795)
High performance valve ~83,0 (3.268)

Standard valve ~70,5 (2.776)
High performance valve ~83,0 (3.268)

Designation **M2** - for 202
covered with rubber bootn

Designation **M5** - for 202
by screwing in of the socket head
screw 2,5(0.098)

Designation **M5** - for 2L2
by screwing in of the socket
head screw 2,5(0.098)

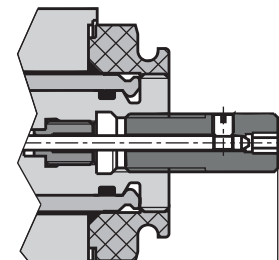
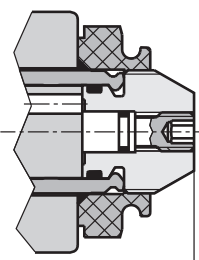
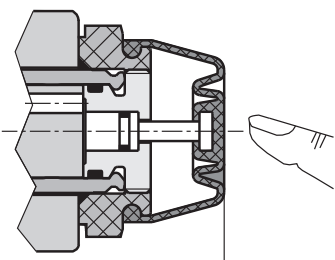

Standard valve ~82,0(3.228)
High performance valve ~100,0(3.937)

Standard valve ~78,0(3.071)
High performance valve ~84,8(3.339)

Standard valve ~78,0(3.071)
High performance valve ~90,0(3.543)

Technical Data

		Standard	High performance
Valve size		B2	
Cartridge cavity		7/8-14 UNF-2A	
Maximum flow	L/min(GPM)	60 (15.85)	75 (19.81)
Max. operating pressure	bar (PSI)	250 (3626)	420 (6091)
Pressure drop	bar (PSI)	see Δp-Q characteristics	
Hydraulic fluid		Hydraulic oils of power classes (HL, HLP) to DIN 51524	
Fluid temperature range	°C (°F)	-20 ... +80 (-4 ...+176)	-20 ... +80 (-4 ...+176)
Ambient temperature, max.	°C (°F)	-20 ... +50 (-4 ...+122)	-20 ... + 80 (-4 ...+176)
Viscosity range	mm ² /s (SUS)	10 ... 500 (49 ... 2450)	
Maximum degree of fluid contamination		Class 21/18/15 according to ISO 4406	
Coil groups ¹⁾		C19B	C22B
Permissible rated voltage variation	%	AC,DC ±10	AC,DC ±15
Max. switching frequency	1/h	15 000	
Duty cycle	%	100	
Service life	cycles	10 ⁷	
Enclosure type to EN 60529 ¹⁾		P 67 (IP 65)	
Valve tightening torque	Nm (lbf.ft)	35+5 (25.81+3.68)	
Plastic nut tightening torque	Nm (lbf.ft)	3+1 (2.213+0.738)	3+1 (2.213+0.738)
Weight	kg (lbs)	0.23 (0.51)	0.30 (0.66)
Mounting position		unrestricted	
Valve body (data sheet HA 0018)		SB-B2	

¹⁾ see data sheet coils HA 8007

p-Q Characteristics

Measured at $v = 32 \text{ mm}^2/\text{s}$ (156 SUS)

Operating limits for hydraulic power transferred by the directional valve. For respective spool type - see functional symbols.

Standard valve

Oil 80 °C (176 °F) / Ambient temperature 50 °C (122 °F)
Voltage Un -10% [V], 24V

High performance valve

Oil 80 °C (176 °F) / Ambient temperature 50 °C (122 °F)
Voltage Un -10% [V], 24V

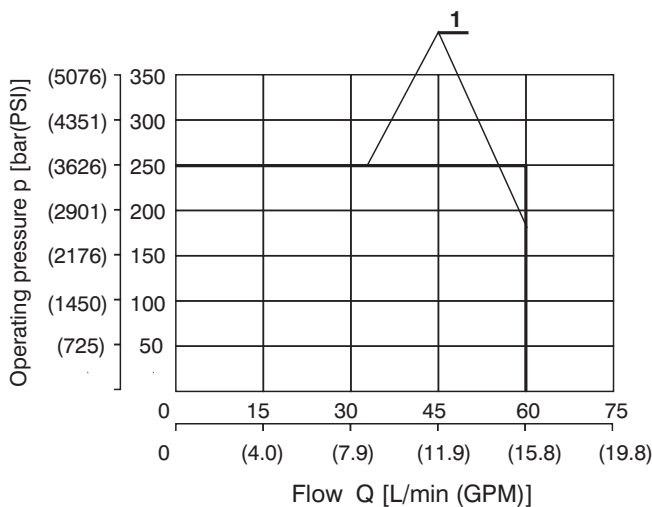

Connection	
1	2L2
1	2O2

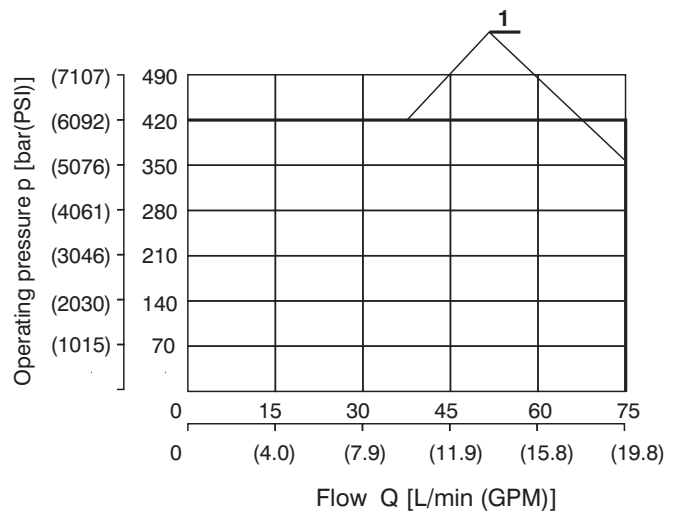

Connection	
1	2L2
1	2O2

Δp-Q Characteristics

Measured at $v = 32 \text{ mm}^2/\text{s}$ (156 SUS)

Pressure drop Δp related to flow rate.

Standard valve + High performance valve

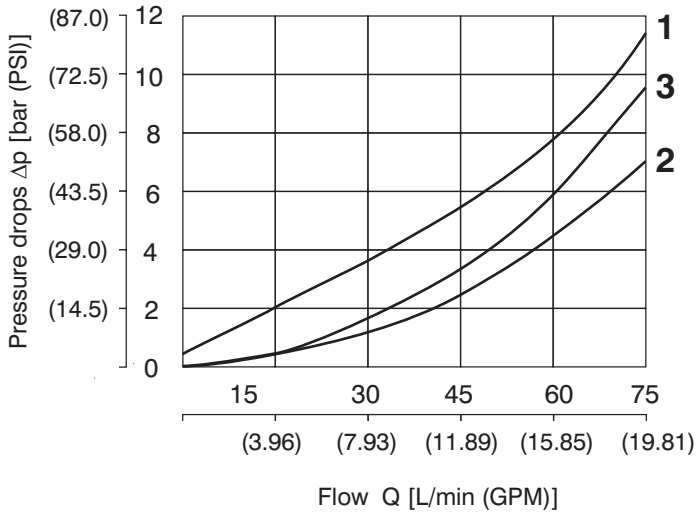

	Connection	Dirrection	Solenoid
1	2L2	1 → 2	switched off
2	2L2	2 → 1	switched on
2	2L2	1 → 2	switched on
2	2O2	1 → 2	switched off
3	2O2	2 → 1	switched off

Type of the Solenoid Coils

Dimensions in millimeters (inches)

Coil for Standard valve C19B

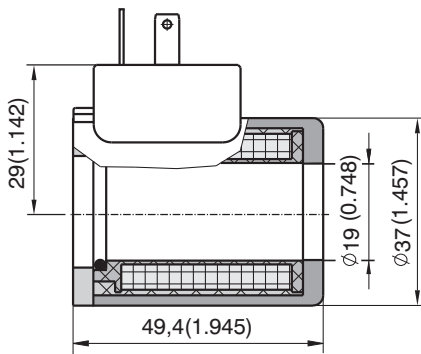

Coil for High performance valve C22B

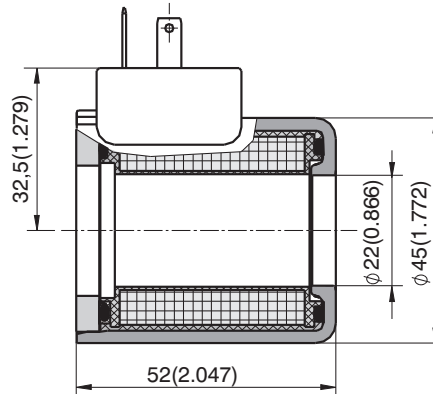

Note:

Example of most frequent coil types.

For complete range of SD3E-B2 valve coils with technical informatik about voltage, enclosure type, terminal box please afer to coil data sheet HA 8007.

Solenoid	Connector	Standard valve	High performance valve
		SD3E-B2 / S...	SD3E-B2 / H...
		Type code	Type code
12 VDC	EN 175301-803-A	C19B-01200E1-6NA	C22B-01200E1-6,55NA
24 VDC	EN 175301-803-A	C19B-02400E1-25,75NA	C22B-02400E1-25,3NA
12 VDC	AMP-Junior-Timer (2-pins)	C19B-01200E3-6NA	C22B-01200E3A-6,55NA
24 VDC	AMP-Junior-Timer (2-pins)	C19B-02400E3-25,75NA	C22B-02400E3A-25,3NA
12 VDC	Flying leads**	C19B-01200E8N300-6NA	C22B-01200E8N300-6,55NA
24 VDC	Flying leads**	C19B-02400E8N300-25,75NA	C22B-02400E8N300-25,3NA
12 VDC	Deutsch DT04-2P	---	C22B-01200E12-6,55NA
24 VDC	Deutsch DT04-2P	---	C22B-02400E12-25,3NA
120 VAC	EN 175301-803-A	C19B-10600E1-494NA*	C22B-10600E1-545NA*
230 VAC	EN 175301-803-A	C19B-20500E1-1653NA*	C22B-20500E1-2353NA*
120 VAC	EN 175301-803-A (with rectifier)	C19B-12060E5-494NA	C22B-12060E5-545NA
230 VAC	EN 175301-803-A (with rectifier)	C19B-23050E5-1653NA	C22B-23050E5-2353NA

*Use the terminal box with rectifier!

**Standard length of connecting wire is 300 mm, other lengths on request.

Valve Dimensions

Dimensions in millimeters (inches)

Standard valve

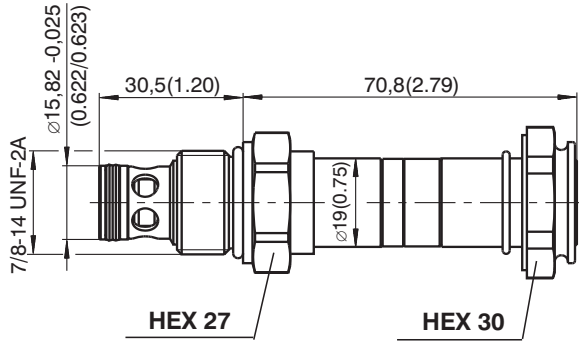

High performance valve

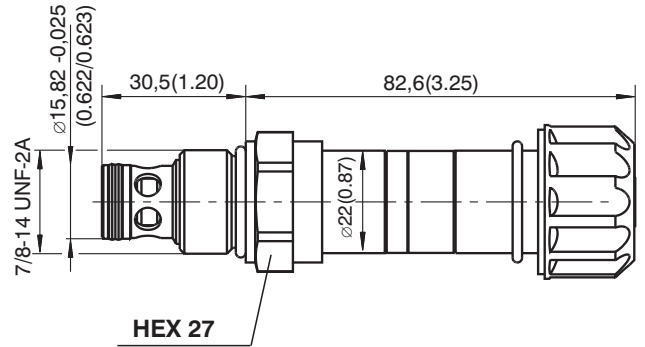

Cavity

Dimensions in millimeters (inches)

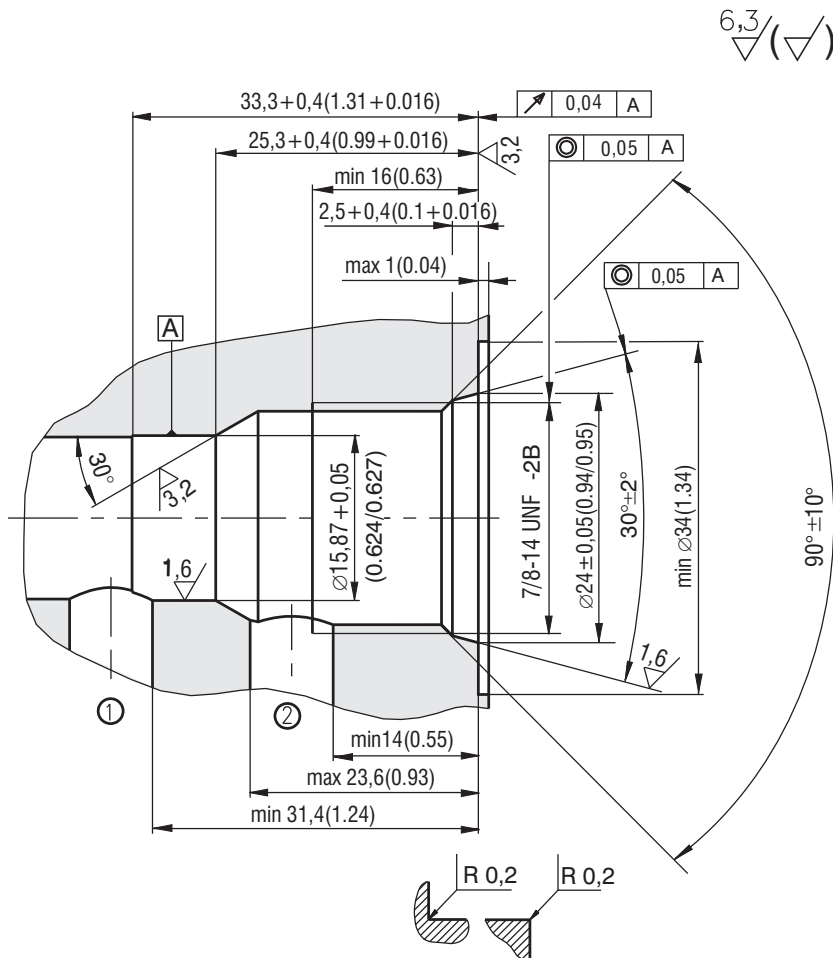

Spare Parts

Dimensions in millimeters

Standard and high performance valve

Dualseal - PU	O-ring - NBR	O-ring - Viton	Ordering number
13,47 x 15,87 x 3,1 (1pc.)	19,4 x 2,1 (1pc.)	-	18960400
13,47 x 15,87 x 3,1 (1pc.)	-	19,4 x 2,1 (1pc.)	18960500

Solenoid retaining nut with seal for standard valve

Type of nut	O-ring - Viton	Ordering number
Standard nut	18 x1,5 (1pc.)	20777000
Nut M2	18 x1,5 (1pc.)	20777600

Solenoid retaining nut with seal for high performance valve

Type of nut	O-ring - Viton	Ordering number
Standard nut	22 x 2 (1pc.)	15844600
Nut M2	22 x 2 (1pc.)	18961700

Caution!

- The packing foil is recyclable.
- The technical information regarding the product presented in this catalogue is for descriptive purposes only. It should not be construed in any case as a guaranteed representation of the product properties in the sense of the law.

ARGO-HYTOS s.r.o. CZ - 543 15 Vrchlabí
 Tel.: +420-499-403 111
 E-mail: info.cz@argo-hytos.com
 www.argo-hytos.com

- Screw-in cartridge, sandwich size 04 (02), size 06 (03) and in-line design
- Leak-free closing up to 3 drops/min at 250 bar
- High switching reliability after long idling time
- High transmitted power

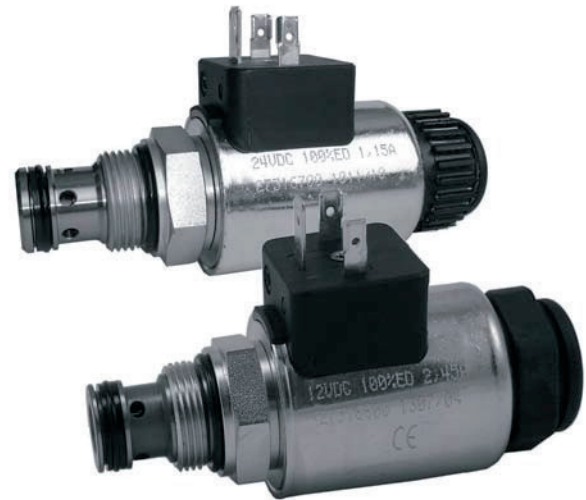
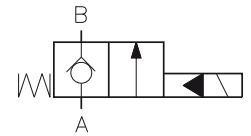

Functional Description

2-way directional poppet valves with solenoid operation are designed to check and open the flow of the hydraulic fluid. The opening and closing of the valve is ensured by an electro-hydraulically controlled poppet (4) which sits on the seat (3) and guarantees in its closed position practically leak-free sealing. The operating solenoid (1) is a DC solenoid. For AC

supply the solenoid is provided with a rectifier which is integrated in the DIN connector socket as part of the solenoid. The electrical connector can be turned by 90°. By loosening the retaining nut (2), the solenoid (1) can be turned arbitrarily in the range of 360°, or replaced. The valve body is zinc coated, bodies M and R are phosphate coated.

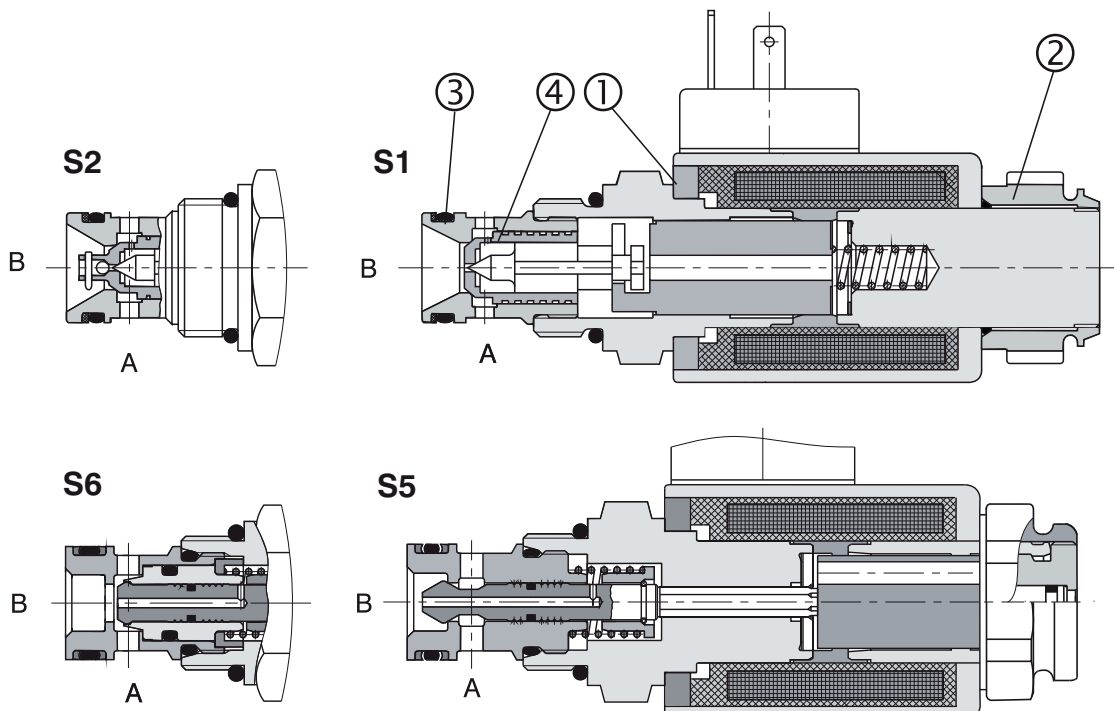

Order Code

1

ROE3 - **2** /

2 Way Directional Poppet Valve with Solenoid Operation

Nominal size

04 (D 02)
06 (D 03)

04
06

Number of operating positions

Model and functional symbols

screw-in cartridge

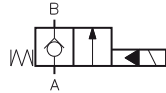

S1

screw-in cartridge

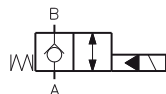

S2

screw-in cartridge

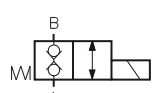

S5*

screw-in cartridge

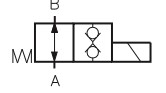

S6*

* only for nominal size 04 (D 02)

Model

screw-in cartridge	no designation	
modular valve, connection of A2 - A1		MA04
modular valve, connection of B2 - B1		MB04
modular valve, connection of A - B		MX04
modular valve, connection of A - T		MD04
modular valve, connection of B - T		ME04
modular valve, connection of B2 - B1, A2 - A1		MC04
modular valve, connection of B - T, A - T		MF04
modular valve, connection of P - T		MG04
modular valve, connection of A2 - A1		MA06
modular valve, connection of B2 - B1		MB06
modular valve, connection of A - B		MX06
modular valve, connection of A - T		MD06
modular valve, connection of B - T		ME06
modular valve, connection of B2 - B1, A2 - A1		MC06
modular valve, connection of B - T, A - T		MF06
modular valve, connection of P - T		MG06
modular valve, connection of P1 -P2		MP06
tube-mounting valve, thread G3/8		R1
tube-mounting valve, thread G1/2		R2
tube-mounting valve, thread SAE8, 3/4-16		R3
tube-mounting valve, thread SAE 10,7/8-14		R4

Seals
no designation
V

NBR
FPM (Viton)

****Electrical connector, EN 1745301-803**

no designation without connector
K1 connector without rectifier
K2 connector without rectifier with LED and quenching diode
K3 connector with rectifier
K4 connector with rectifier with LED and quenching diode
K5 connector without rectifier

Type of solenoid coil

E1 with terminal for the connector, EN 1745301-803
E2 with terminal for the connector, EN 1745301-803 and quenching diode
E3 with AMP-Junior-Timer-connector
E4 with AMP-Junior-Timer-connector and quenching diode
E5 with integrated rectifier and with terminal for the connector, EN 1745301-803

Rated supply voltage of solenoids

01200	12 V DC / 2.41 A
01400	14 V DC / 1.66 A
02100	21 V DC / 1.14 A
02400	24 V DC / 1.15 A
04200	42 V DC / 0.59 A
04800	48 V DC / 0.56 A
06000	60 V DC / 0.41 A
10200	102 V DC / 0.24 A
20500	205 V DC / 0.12 A
02450	24 V AC / 1.44 A / 50 (60) Hz
11550	115 V AC / 0.26 A / 50 (60) Hz
23050	230 V AC / 0.14 A / 50 (60) Hz

**Note: Electrical connectors have to be ordered separately see page 13 and 15

FOR PREFERRED TYPES SEE BOLD TYPING IN ORDERING CODE, AND TABLE OF PREFERRED TYPES ON PAGE 15

Recommended solenoid coils used with electrical connector with rectifiers - type designation K3, K4

Rated supply source voltage (permissible rated voltage variation ±10 %)	Type designation of the solenoid voltage
24 V AC / 1.44 A / 50 (60) Hz	02100
115 V AC / 0.26 A / 50 (60) Hz	10200
230 V AC / 0.14 A / 50 (60) Hz	20500

Ordering Numbers of Sandwich / Valve Bodies (without screw-in cartridge)

Modular valve - sealing NBR	Order number	Modular valve - sealing Viton	Order number
MA04-ROE3	15652600	MA04-ROE3/V	28592100
MB04-ROE3	15652800	MB04-ROE3/V	28592500
MX04-ROE3	15652900	MX04-ROE3/V	28592600
MD04-ROE3	15653000	MD04-ROE3/V	28592700
ME04-ROE3	15653100	ME04-ROE3/V	28593000
MC04-ROE3	15653200	MC04-ROE3/V	28593100
MF04-ROE3	15653300	MF04-ROE3/V	28593200
MG04-ROE3	15653800	MG04-ROE3/V	20717800
MA06-ROE3	15649200	MA06-ROE3/V	28593400
MB06-ROE3	15649300	MB06-ROE3/V	28593700
MX06-ROE3	15649400	MX06-ROE3/V	28594000
MD06-ROE3	16687400	MD06-ROE3/V	28594300
ME06-ROE3	15649600	ME06-ROE3/V	28594400
MC06-ROE3	15649700	MC06-ROE3/V	28594500
MF06-ROE3	15649800	MF06-ROE3/V	20690300
MG06-ROE3	15649900	MG06-ROE3/V	20690500
MP06-ROE3	16687500	MP06-ROE3/V	20690800
Tube-mounting valve	Order number	Tube-mounting valve	Order number
R1-ROE3	15653400	R3-ROE3	15653600
R2-ROE3	15653500	R4-ROE3	15653700

Functional Symbols

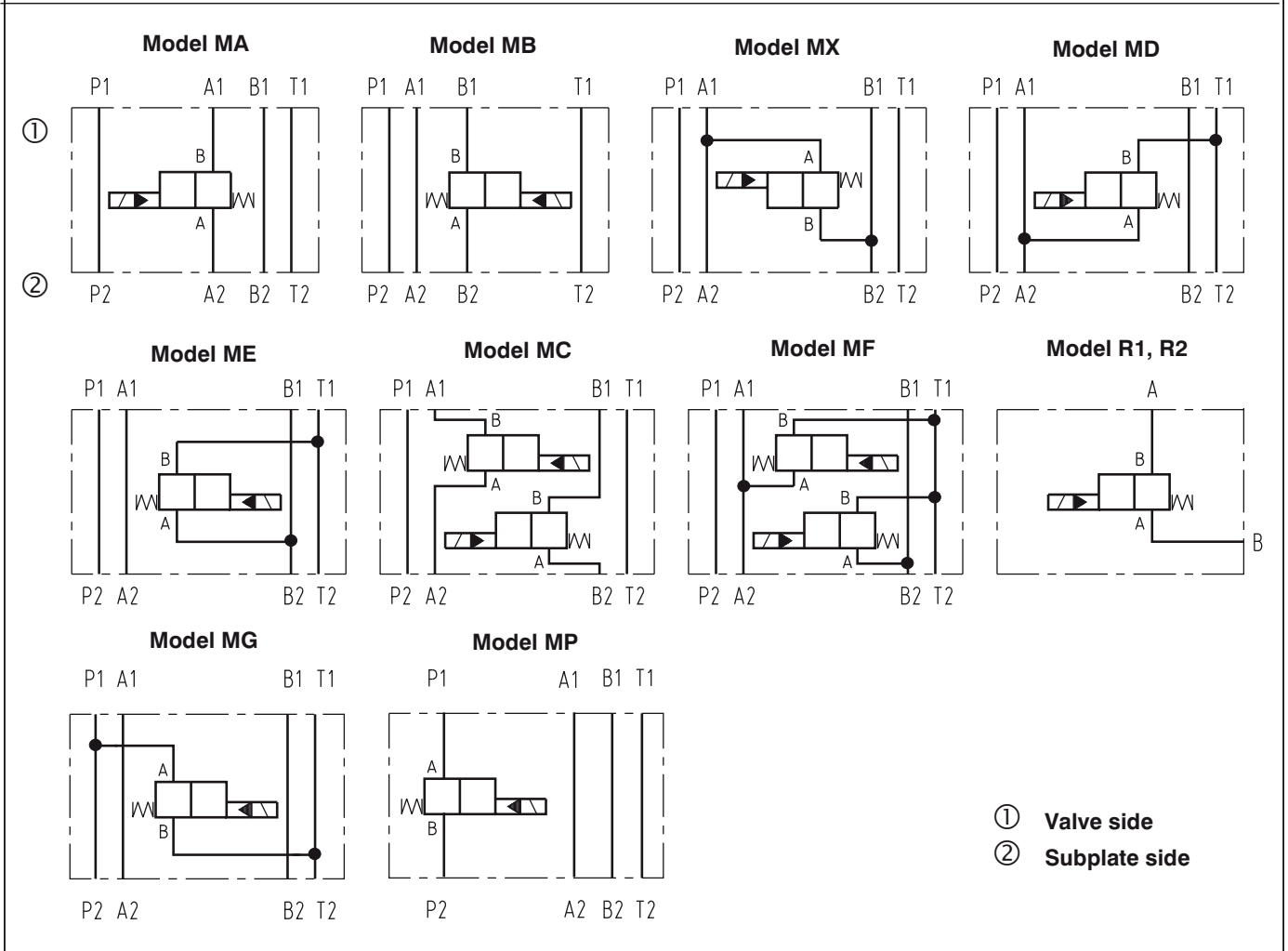

Technical Data

Valve size	mm (US)	04 (D 02)	06 (D 03)
Maximal flow	L/min (GPM)	25 (6.6)	63 (13)
Maximal operating pressure	bar (PSI)	250 (3600)	250 (3600)
Pressure drop	bar (PSI)	see Δp -Q characteristics	
Hydraulic fluid		Hydraulic oils of power classes (HL, HLP) to DIN 51524	
Fluid temperature range	°C (°F)	-30 ... +80 (-22 ... +176) for NBR seals -20 ... +80 (-4 ... +176) for FPM seals	
Ambient temperature, max.	°C (°F)	50 (+122)	
Viscosity range	mm ² /s (SUS)	20 ... 400 (98 ... 1840)	
Maximum degree of fluid contamination		Class 21/18/15 according to ISO 4406	
Permissible rated voltage variation	%	DC: ± 10 AC: ± 10	
Maximal switching frequency	1/h	15 000	10 000
Switching time, ON; at rated voltage and $v = 32 \text{ mm}^2/\text{s}$ (156 SUS)	ms	DC 25 ... 35 AC 25 ... 35	DC 30 ... 50 AC 30 ... 110
Switching time, OFF; at $v = 32 \text{ mm}^2/\text{s}$ (156 SUS)	ms	DC 15 ... 25 AC 50 ... 100	DC 80 ... 130 AC 100 ... 150
Duty cycle	%	100	
Service life		10^7	
Enclosure type to EN 60 529		IP 65	
Weight - screw-in cartridge - model MA, MB, MX, MD, ME, MG, MP - model MC, MF - model R1, R2, R3, R4	kg (lbs)	0.5 (1.1) 1.15 (2.5) 1.65 (3.6) 1.60 (3.5)	0.5 (1.1) 1.45 (3.2) 1.95 (4.3) 1.60 (3.5)
Mounting position		unrestricted	

Δp -Q Characteristics

Measured at $v = 32 \text{ mm}^2/\text{s}$ (156 SUS)

For the screw-in cartridge without valve body

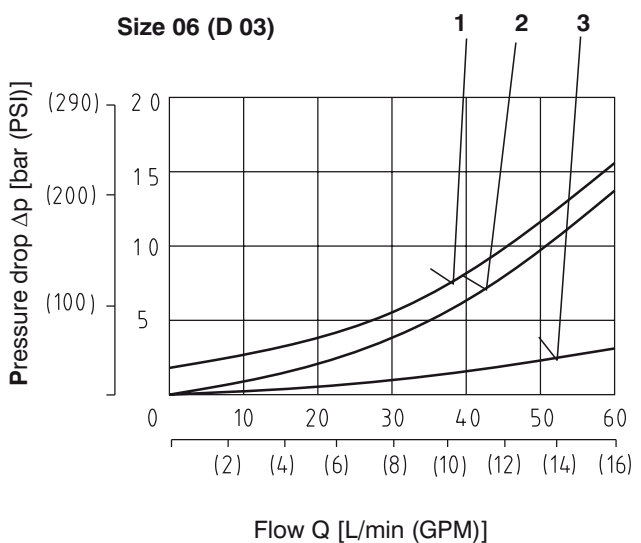
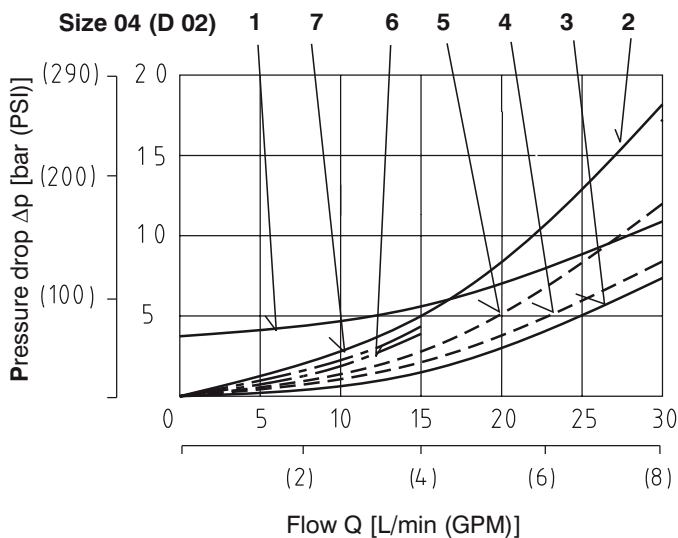

- 1 - S1, S2 (B - A) Solenoid OFF
 - 2 - S1, S2 (A - B) Solenoid ON
 - 3 - S2 (B - A) Solenoid ON
 - 4 - S5 (A - B)
 - 5 - S5 (B - A)
 - 6 - S6 (A - B)
 - 7 - S6 (B - A)
- flow up to 15 L/min (4 GPM)

- 1 - S1, S2 (B - A) Solenoid OFF
- 2 - S1, S2 (A - B) Solenoid ON
- 3 - S2 (B - A) Solenoid ON

In connection with a valve body, the additional pressure loss of the valve body is to be considered.

Δp-Q Characteristics

Measured at $v = 32 \text{ mm}^2/\text{s}$ (156 SUS)

Pressure drops for valves S1, S2 in sandwich blocks Blocks R1, R2, R3, R4 for inline-mounting

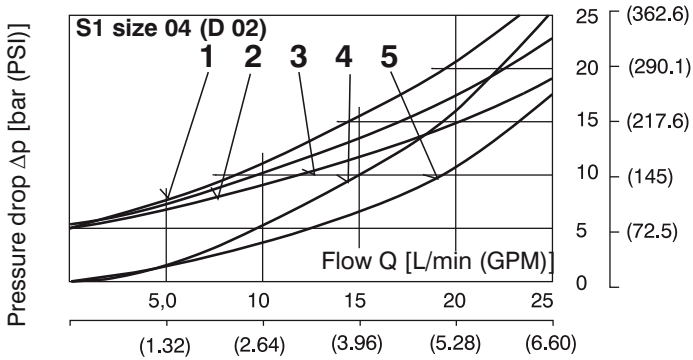

- 1 - MD 04 (T-A)
- 2 - MX 04 (B-A)
- 3 - MA 04 (A1-A2)
- 4 - MX 04 (A-B), MD 04 (A-T), MG 04 (P-T)
- 5 - MA 04 (A2-A1)

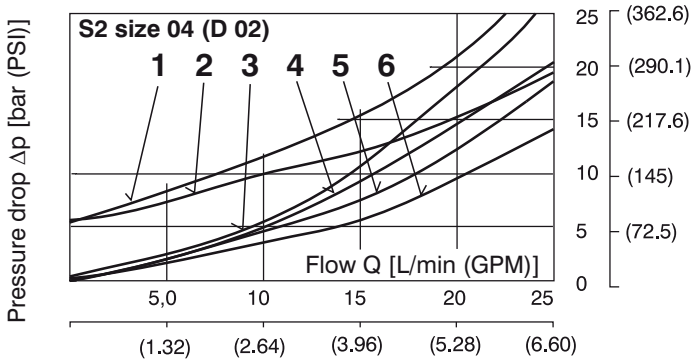

- 1 - MD 04 (T-A) Solenoid OFF
MX 04 (B-A) Solenoid OFF
- 2 - MA 04 (A1-A2) Solenoid OFF
- 3 - MD 04 (A-T)
- 4 - MA 04 (A2-A1)
MD 04 (T-A) Solenoid ON
- 5 - MX 04 (B-A) Solenoid ON
- 6 - MA 04 (A1-A2) Solenoid ON

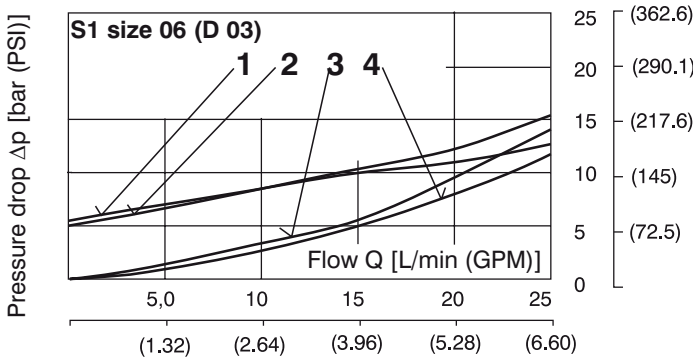

- 1 - MA 06 (A1-A2), MX 06 (B-A)
- 2 - MD 06 (T-A)
- 3 - MD 06 (A-T), MG 06 (P-T)
- 4 - MA 06 (A2-A1), MX 06 (A-B)

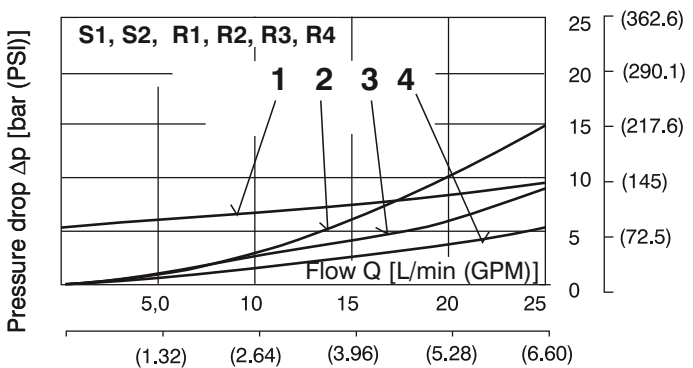

- 1 - S2 R1 (R3), (A-B) Solenoid OFF
S2 R2 (R4), (A-B) Solenoid OFF
S1 R1 (R3), (A-B), S1 R4 (A-B)
- 2 - S2 R1 (R3), (B-A), S2 R4 (B-A)
- 3 - S1 R1 (R3), (B-A), S1 R4 (B-A)
- 4 - S2 R1 (R3), (A-B) Solenoid ON
S2 R2 (R4), (A-B) Solenoid ON

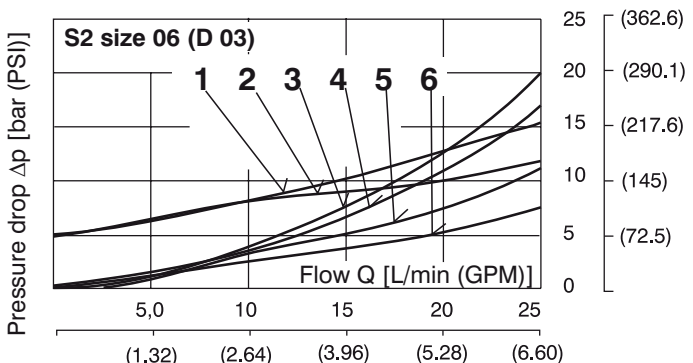

- 1 - MD 06 (T-A) Solenoid OFF
- 2 - MX 06 (B-A) Solenoid OFF
MA 06 (A1-A2) Solenoid OFF
- 3 - MD 06 (A-T)
- 4 - MA 06 (A2-A1), MX 06 (A-B)
- 5 - MD 06 (A-T)
- 6 - MA 06 (A1-A2) Solenoid ON
MX 06 (B-A) Solenoid ON

Δp-Q Characteristics

Measured at $v = 32 \text{ mm}^2/\text{s}$ (156 SUS)

Pressure drops for valves S5, S6 in modular blocks

Blocks R1, R2, R3, R4 for thread connection

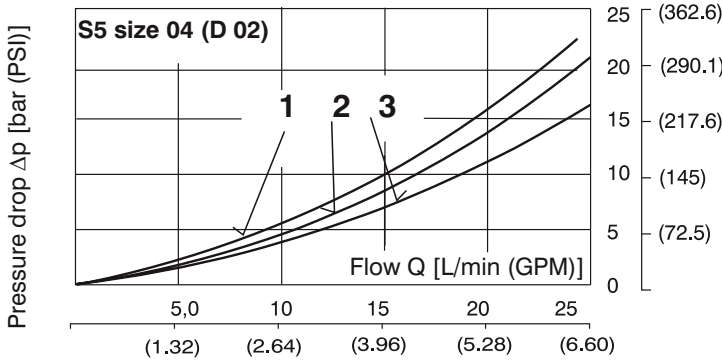

- 1** - MD 04 (A-T, T-A), ME 04 (B-T, T-B)
MF 04 (A-T, T-A)
- 2** - MX 04 (A-B, B-A)
- 3** - MA 04 (A1-A2, A2-A1), MB 04 (B1-B2, B2-B1)

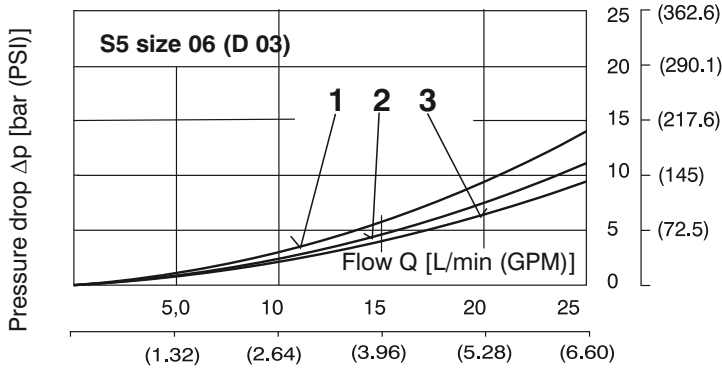

- 1** - MD 06 (A-T, T-A), ME 06 (B-T, T-B)
MF 06 v(A-T, B-T / T-A, T-B)
- 2** - MA 06 (A1-A2), MB 06 v(B1-B2),
MC 06 (A1-A2 / B1-B2), MX (B-A)
- 3** - MA 06 (A2-A1), MB 06 (B1-B2)
MC 06 (A2-A1/B2-B1), MX 06 (A-B)

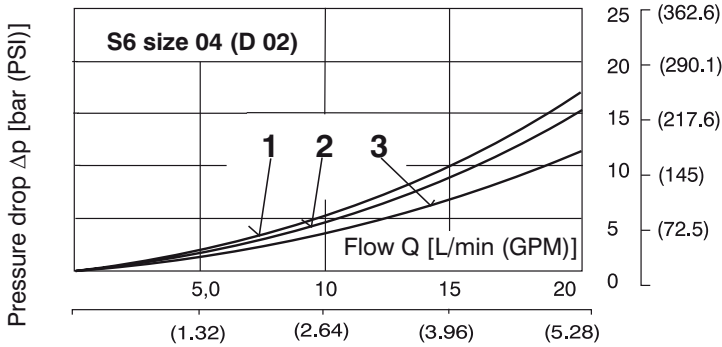

- 1** - MD 04 (A-T, T-A), ME 04 (T-B, B-T)
MF 04 (A-T, B-T / T-A, T-B)
- 2** - MX 04 (A-B, B-A)
- 3** - MA 04 (A1-A2, A2-A1), MB (B1-B2, B2-B1)
MC 04 (A1-A2, A2-A1 / B1-B2, B2-B1)

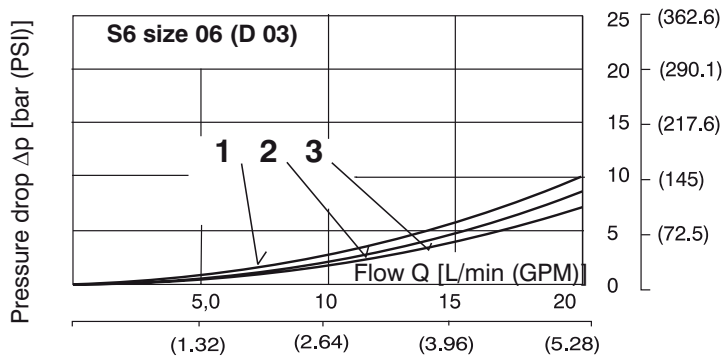

- 1** - MD (T-A), ME (T-B), MF (T-A, T-B)
- 2** - MD (A-T), ME (B-T), MF (A-T, B-T)
- 3** - MA (A1-A2, A2-A1), MB (B1-B2, B2-B1)
MC (A1-A2, A2-A1 / B1-B2, B2-B1)

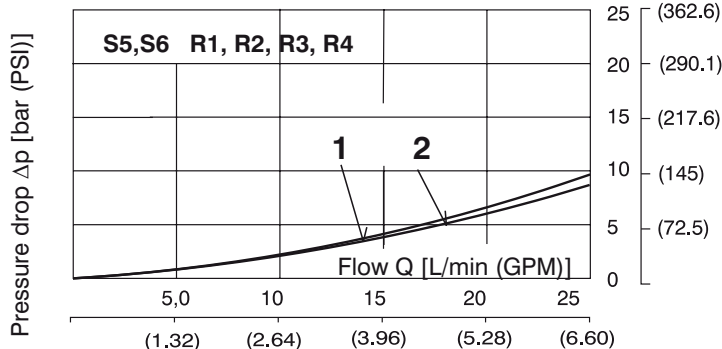

- S5** **1** - R1 (R3) A-B, B-A
2 - R2 (R4) A-B, B-A
- S6** **1** - R1 (R3) A-B, B-A
2 - R2 (R4) A-B, B-A

p-Q Characteristics

Measured at $v = 32 \text{ mm}^2/\text{s}$ (156 SUS)

Operating limits for maximum hydraulic power for valves S1, S2, S5, S6

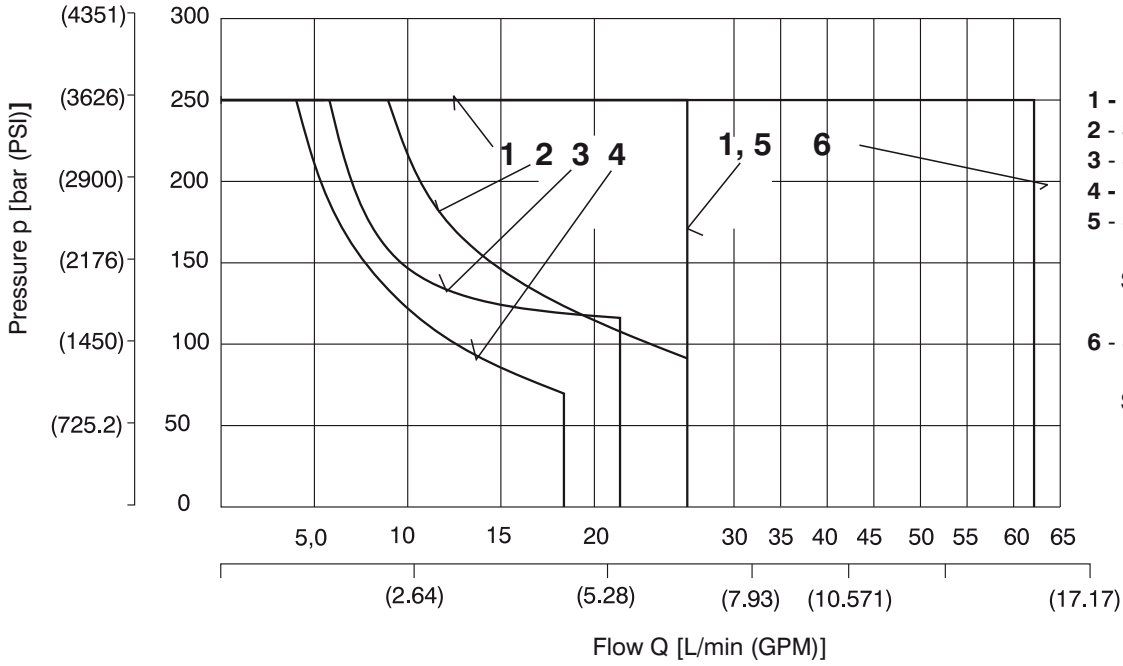

- 1 - S5 (A-B)
- 2 - S5 (B-A)
- 3 - S6 (A-B)
- 4 - S6 (B-A)
- 5 - S1 Size 04 (D 02) (A-B)
S2 Size 04 (D 02) (A-B, B-A)
- 6 - S1 Size 06 (D 03) (A-B)
S2 Size 06 (D 03) (A-B, B-A)

Valve Dimensions

Dimensions in millimeters (inches)

Size 04 (D 02), 06 (D 03) - Screw-in cartridge

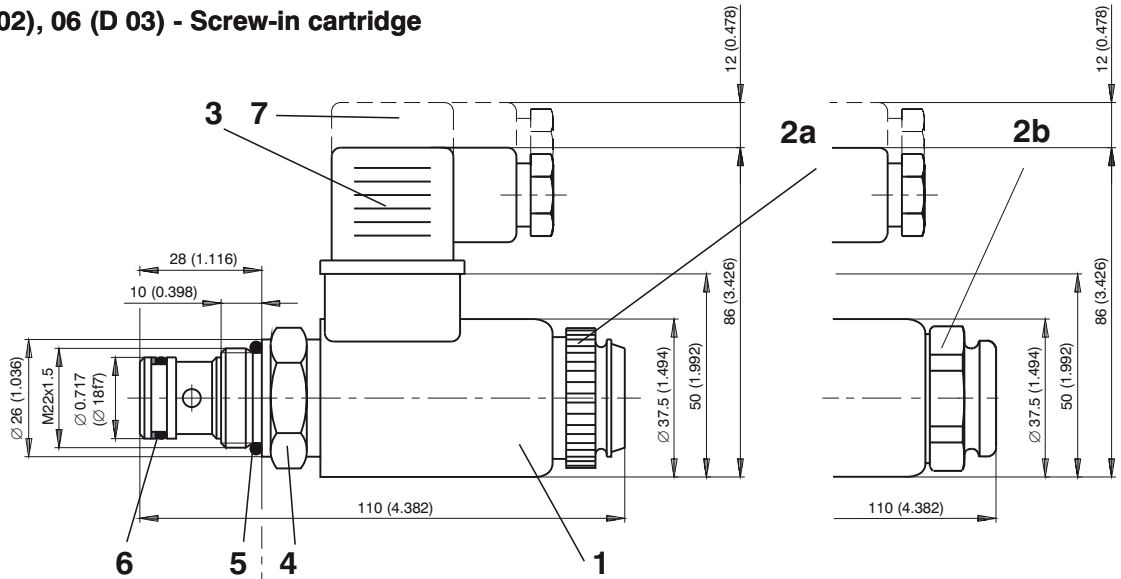

Cavity

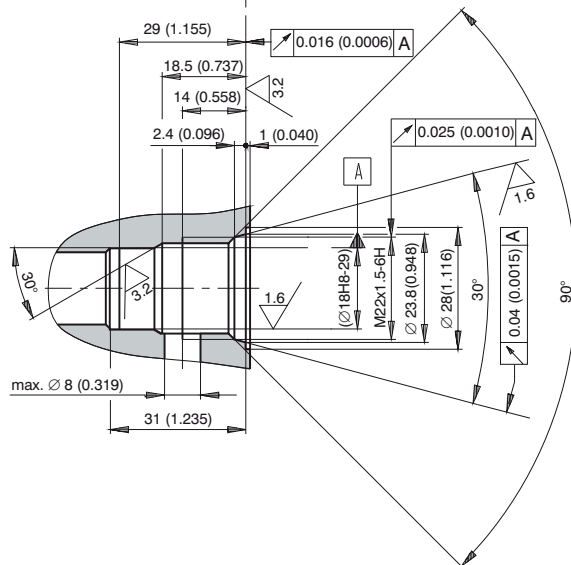

- 1 Solenoid turnable in the range of 360°
- 2a Retaining nut of the solenoid size 06 [Nut torque 3 Nm (2.21 ft-lbs)]
- 2b Retaining nut of the solenoid size 04 [Nut torque 3 Nm (2.21 ft-lbs)]
- 3 Electrical connector, EN 175301-803
- 4 Outside hexagon $s = 27 \text{ mm}$ (1.06 in.)
Tightening torque 25 Nm (18.5 ft-lbs)
- 5 O-ring 19.4 x 2.1 NBR 80 (1 pc.)
supplied with valve
- 6 Combined sealing:
O-ring 14 x 1.78 (1 pc.)
Back-up ring 14.73 x 17.43 x 1.14 (1 pc.)
supplied with valve
- 7 Space required to remove connector

Valve Dimensions

Dimensions in millimeters (inches)

Size 04 (D 02)- S5, S6 - Connecting dimensions according to ISO 4401, CETOP - RP 121H
Model MA, MX, MD, MG

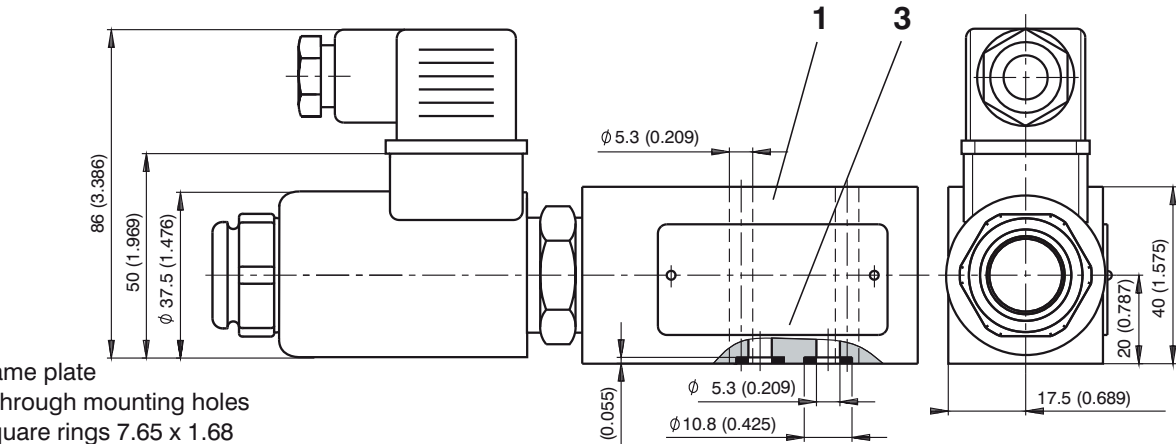

- 1 Name plate
- 2 4 through mounting holes
- 3 Square rings 7.65 x 1.68
(4 pcs. supplied with valve)

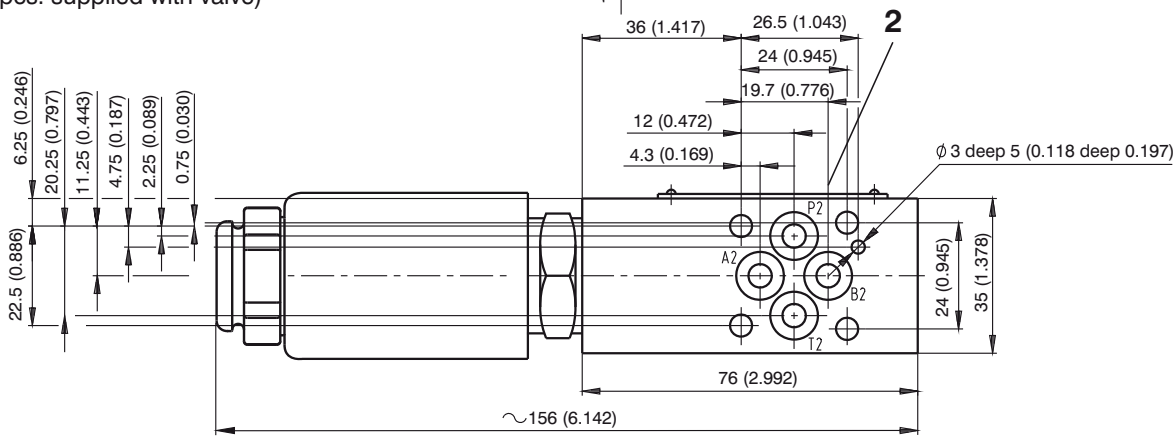

Model MB, ME

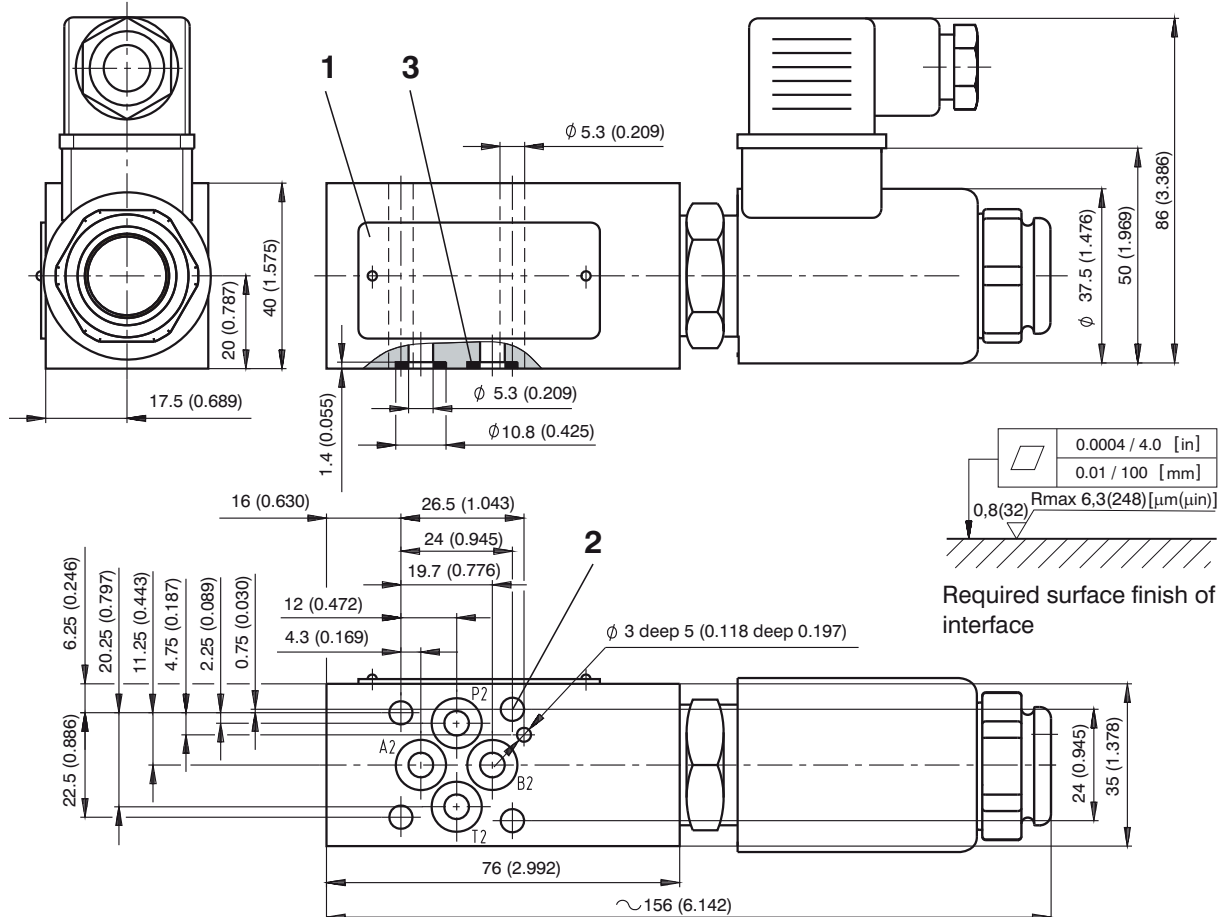

0.0004 / 4.0 [in]
 0.01 / 100 [mm]
 $R_{max} 6.3(248) [\mu m(\mu in)]$
 0,8(32)

Required surface finish of interface

Valve Dimensions

Dimensions in millimeters (inches)

Model MC, MF

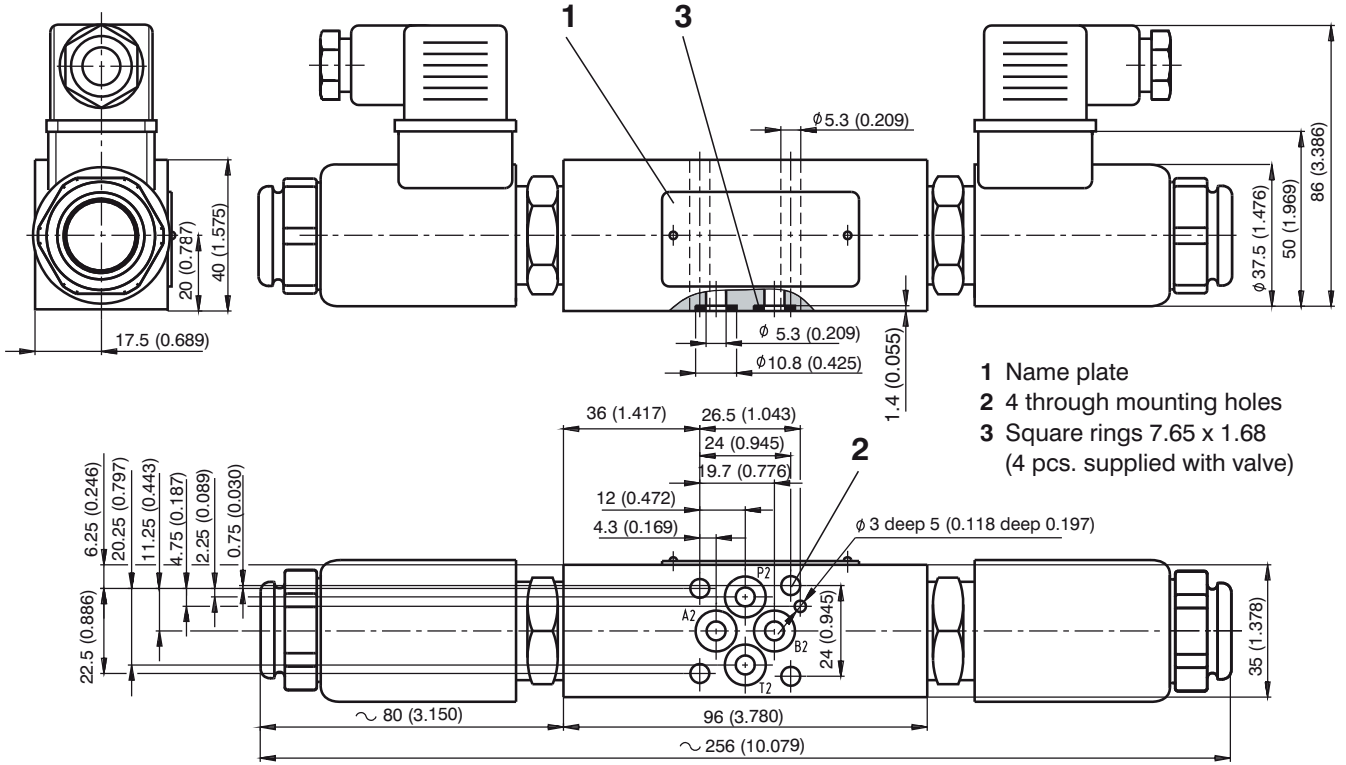

- 1 Name plate
- 2 4 through mounting holes
- 3 Square rings 7.65 x 1.68 (4 pcs. supplied with valve)

Valve Dimensions

Dimensions in millimeters (inches)

Size 06 (D 03) - S1, S2 - Connecting dimensions according to ISO 4401, DIN 24 340

Model MA, MX, MD, MG, MP

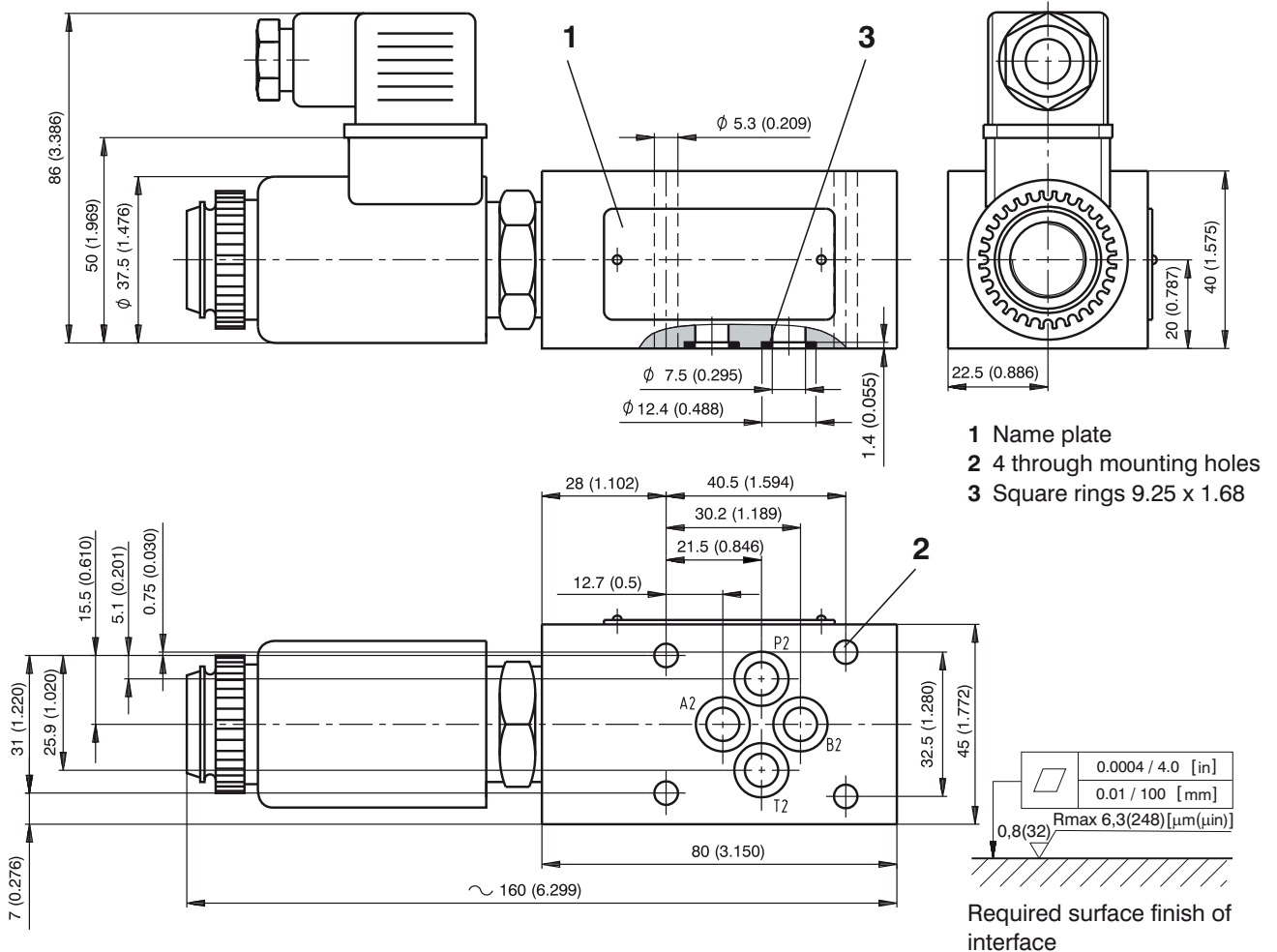

- 1 Name plate
- 2 4 through mounting holes
- 3 Square rings 9.25 x 1.68

Valve Dimensions

Dimensions in millimeters (inches)

Model MB, ME

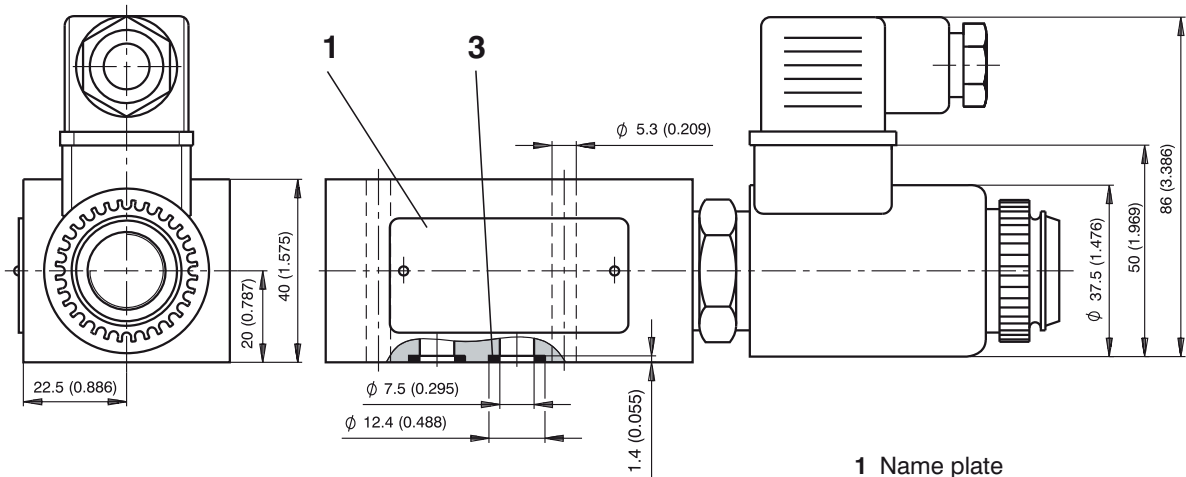

- 1 Name plate
- 2 4 through mounting holes
- 3 Square rings 9.25 x 1.68
(4 pcs. supplied with valve)

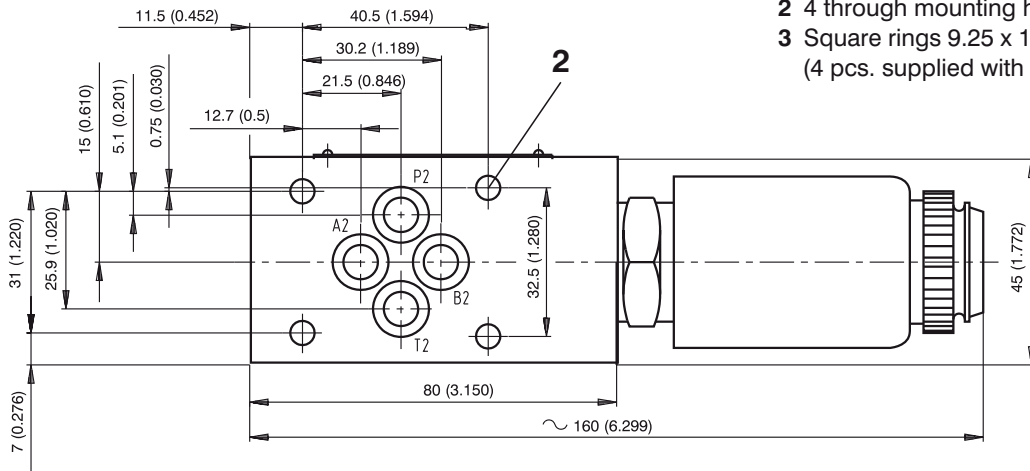

Model MC, MF

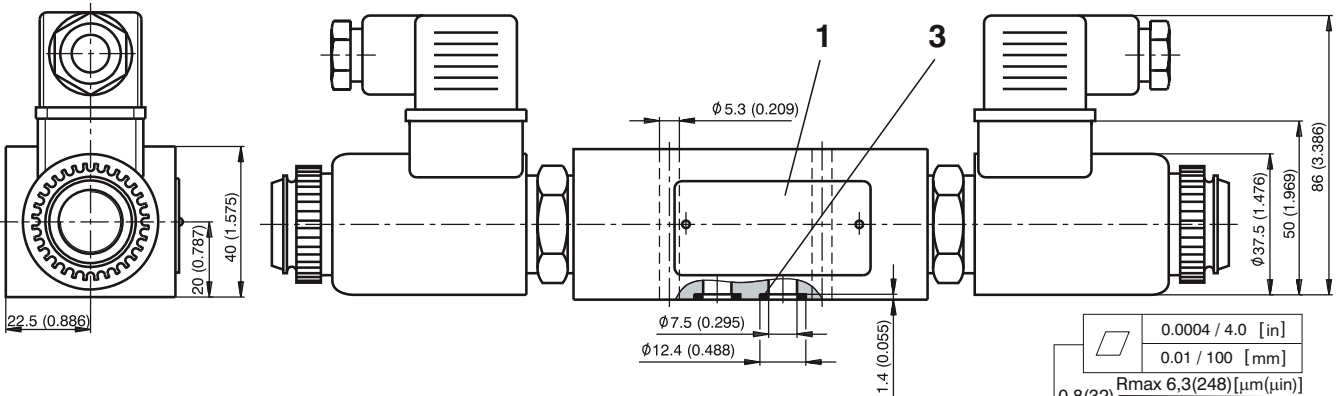

	0.0004 / 4.0 [in]
	0.01 / 100 [mm]

0,8(32) Rmax 6,3(248) [μm(μin)]

Required surface finish of interface

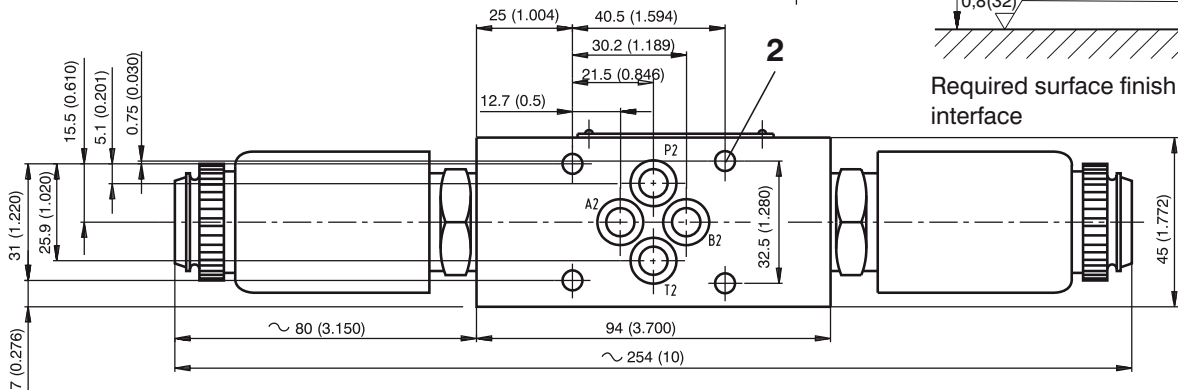

Valve Dimensions

Dimensions in millimeters (inches)

Model R1

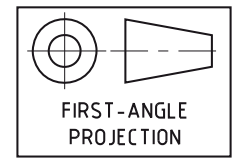
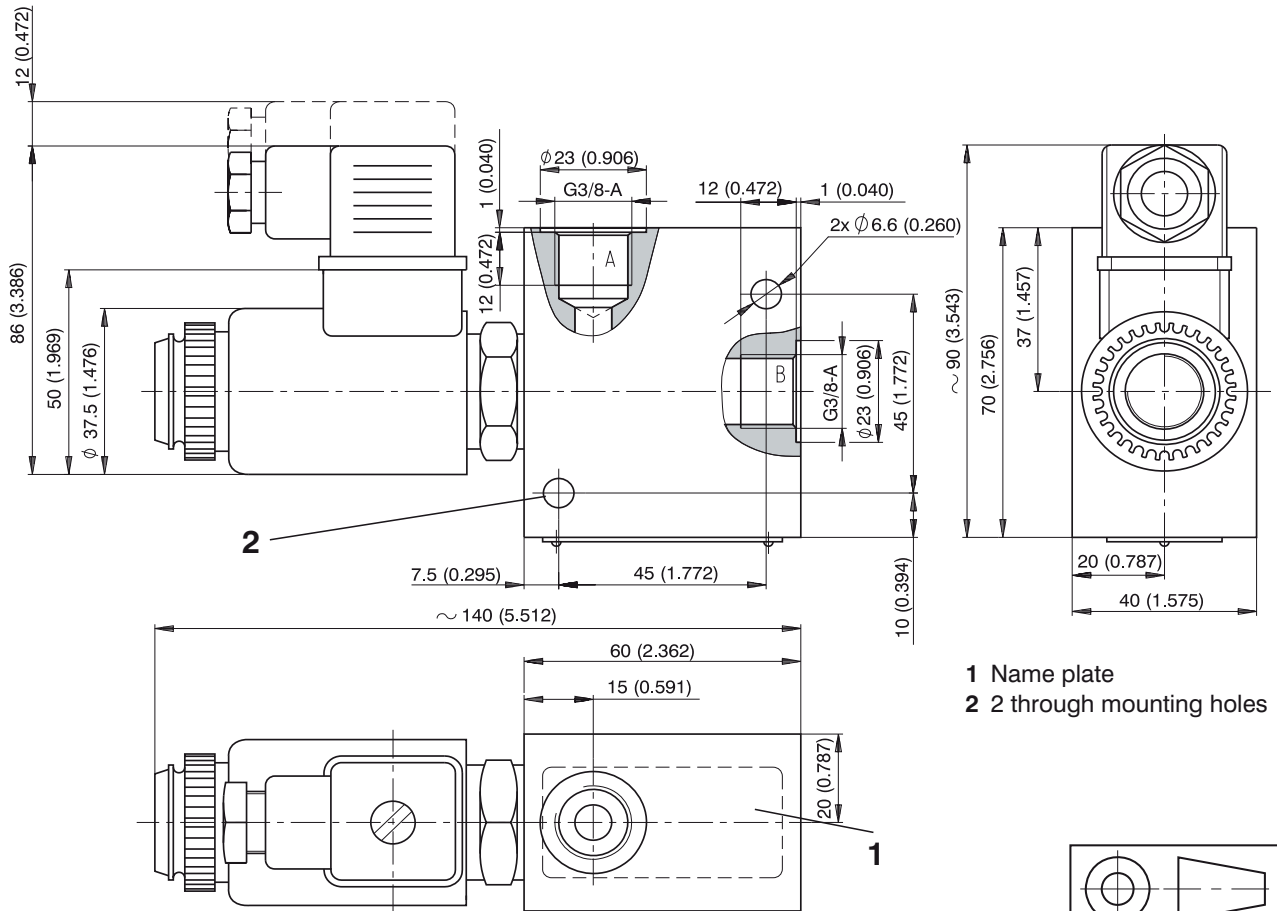

Model R2

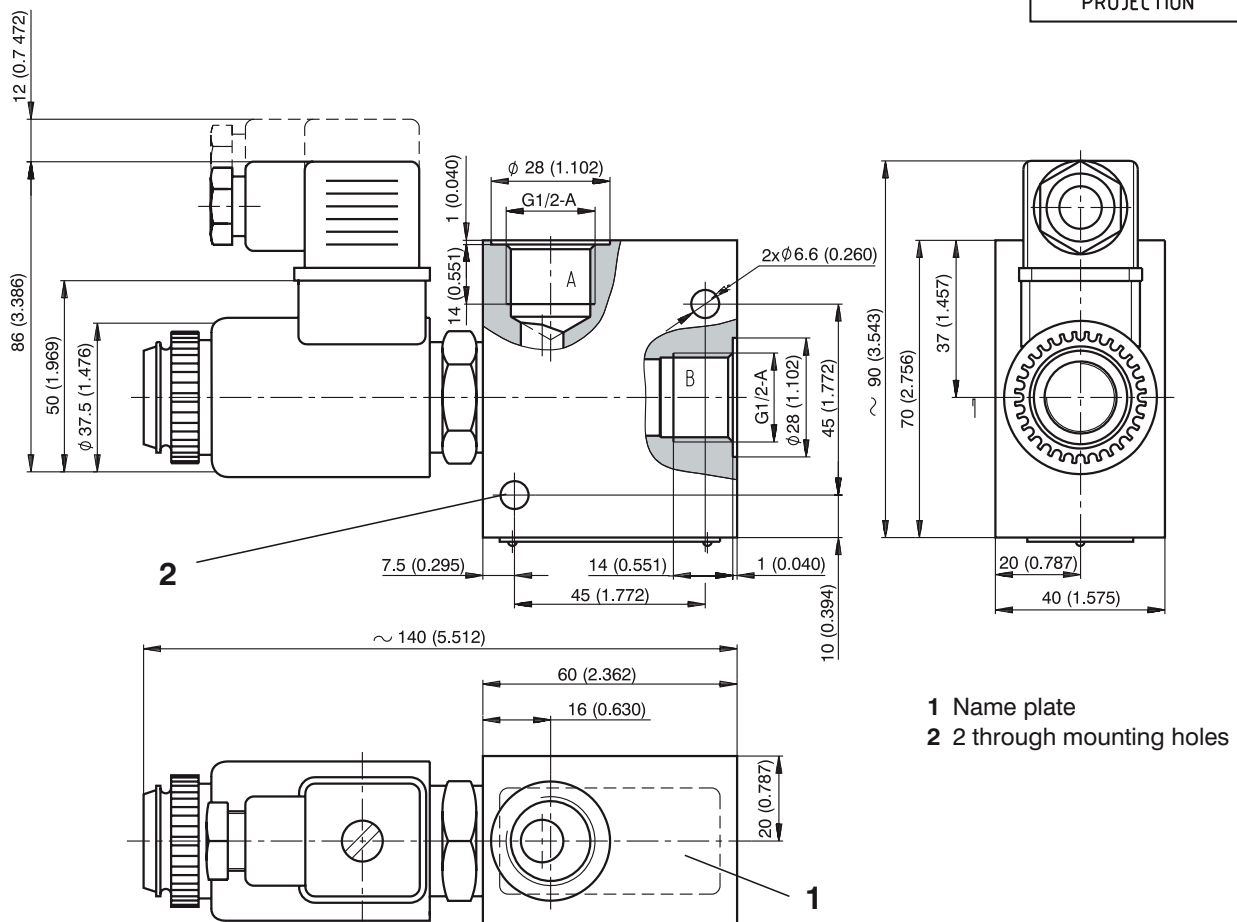

Valve Dimensions

Dimensions in millimeters (inches)

Model R3

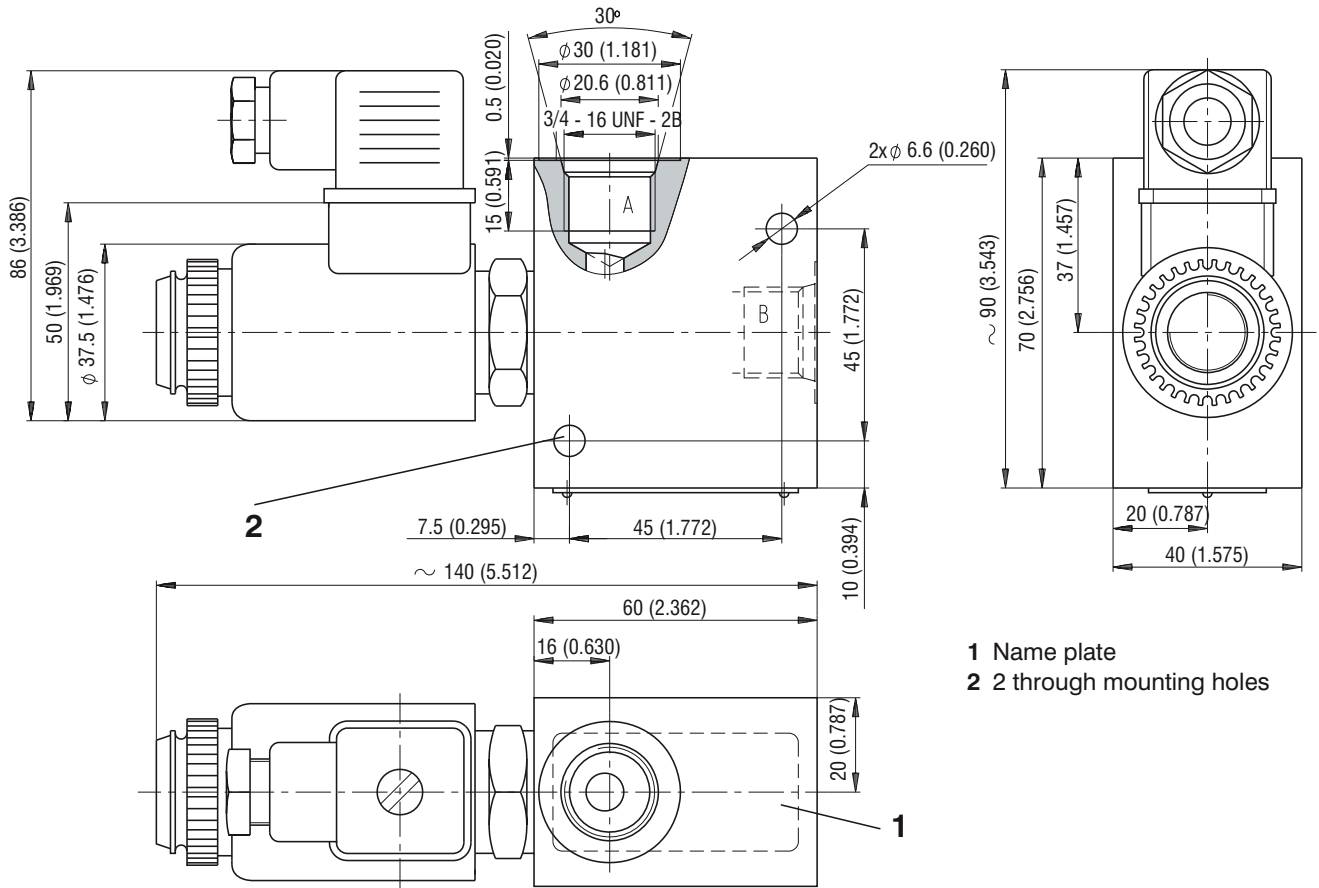

- 1 Name plate
- 2 2 through mounting holes

Model R4

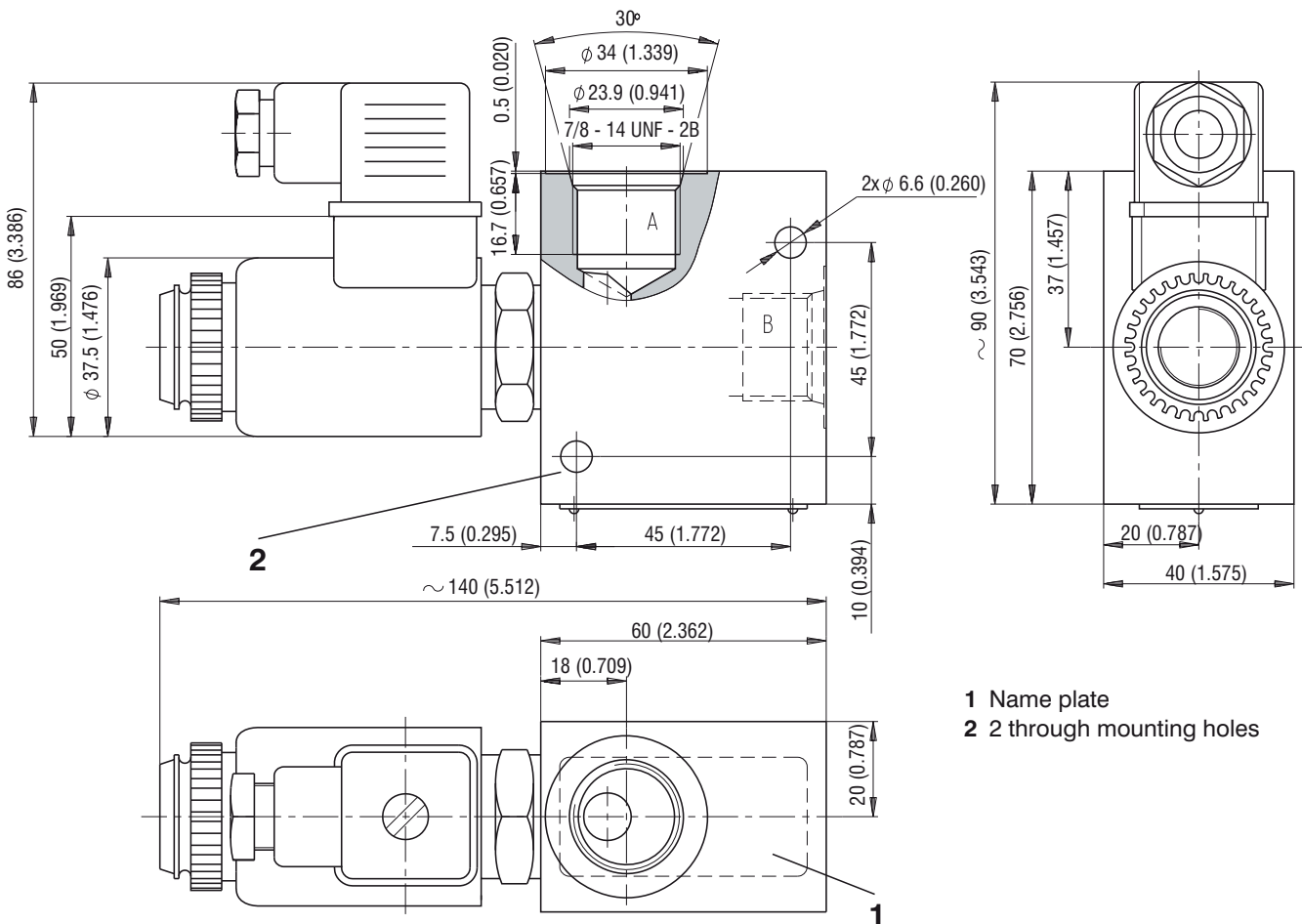

- 1 Name plate
- 2 2 through mounting holes

Type of the Solenoid Coil

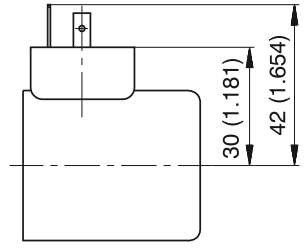
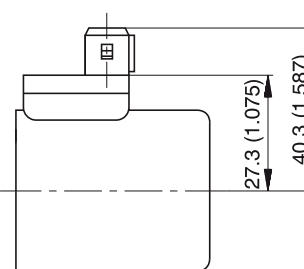
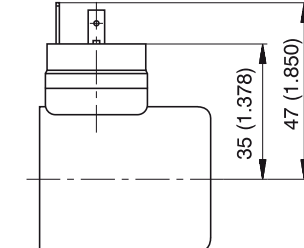
Designation	Dimensional sketch	Description
E1		Solenoid coil with terminal for the electrical connector, EN 175301-803
E2		Solenoid coil with integrated quenching diode (bipolar transistor diode) and terminal for the electrical connector, EN 175301-803
E3		Solenoid coil with terminal for AMP electrical connector.
E4		Solenoid coil with integrated quenching diode (bipolar transistor diode) and terminal for AMP electrical connector.
E5		Solenoid coil with integrated rectifier and terminal for the electrical connector, EN 175301-803

Electrical Connector, EN 175301-803

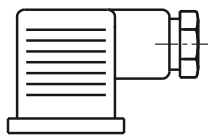
Designation	Type	Model	Max. input voltage	
K1	Connector B (black)	without rectifier - M16x1.5	230 V AC/DC	
	Connector A (grey)	bushing bore \varnothing 6-8 mm (0.236 - 0.315 in)		
K5	Connector B (black)	without rectifier - M16x1.5	230 V AC/DC	
	Connector A (grey)	bushing bore \varnothing 4-6 mm (0.158 - 0.236 in)		
K2	Connector B (black)	without rectifier with LED	12...24 V DC	
	Connector A (grey)	and quenching diode - M16x1.5 bushing bore \varnothing 6-8 mm (0.236 - 0.315 in)		
K3	Connector B (black)	with rectifier - M16x1.5	230 V AC	
	Connector A (grey)	bushing bore \varnothing 6-8 mm (0.236 - 0.315 in)		
K4	Connector B (black)	with rectifier with LED	230 V AC	
	Connector A (grey)	and quenching diode - M16x1.5 bushing bore \varnothing 6-8 mm (0.236 - 0.315 in)		

Solenoid coil

Type designation of the coil voltage	Type of the coil					
	E1	E2	E3	E4	E5	
	\varnothing 6-8 mm (0.236)					
01200	27316600	27631400	27330200	27631600		
01400	27634100	27634200	27634300	27634400		
02400	27316700	27632400	27330300	27633200		
02700	27636100	27639400	27641600	27641700		
04800	27825500	-	-	-		
10600	27642600	-	-	-		
01200 CSA	24140700	-	-	-		
02400 CSA	24140800	-	-	-		
11550 CSA						24140900
23050 CSA						24141000

Spare Parts

- 1 Solenoid coil
- 2a Retaining nut with seal for size 06 (S1, S2)
- 2b Retaining nut with seal for size 04 (S5, S6)
- 3 Electrical connector
- 4 Seal kit

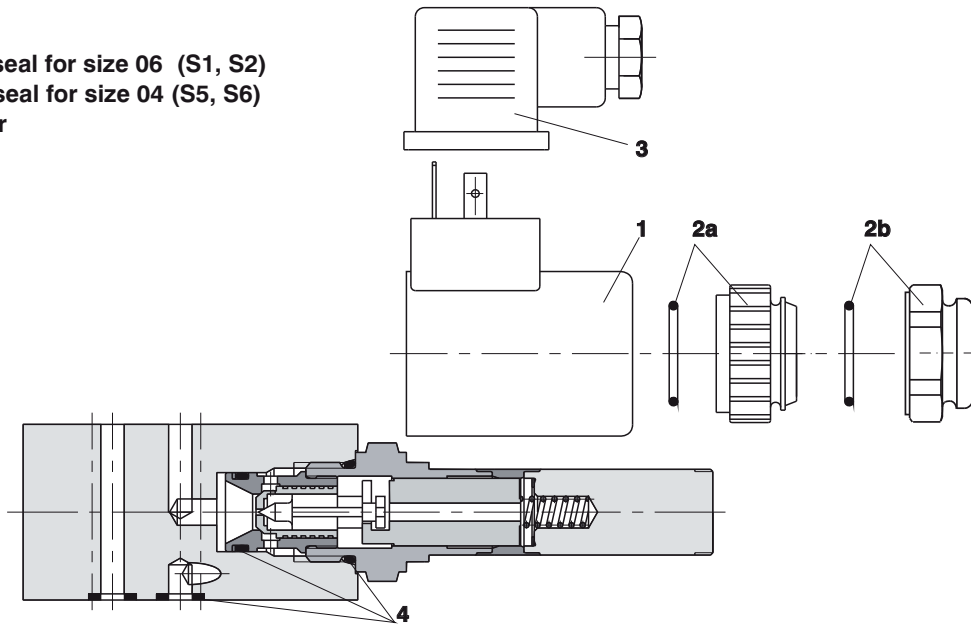

Solenoid retaining nut with seal

Type of the nut	Seal ring	Order number
Standard nut for size 06 (S1, S2)	18 x 1.5	17314100
Standard nut for size 04 (S5, S6)	18 x 1,5	15874500
Standard		

Electrical connector, EN 175301-803

Type	Connector A gray	Connector B black
	Order number	
K1	16202200	16202100
K5	16202600	16202500
K2	16202800	16202700
K3	16202400	16202300
K4	16203000	16202900

Seal kit

Type	Model	Dimensions, quantity	Order number
ROE3	O-ring - NBR 80	19.4 x 2.1 (1 pc.)	15650200
	O-ring - NBR 80	14 x 1.78 (1 pc.)	
	Back-up ring	14.73 x 17.43 x 1.14 (1 pc.)	
ROE3	O-ring - Viton	19.4 x 2.1 (1 pc.)	16954700
	O-ring - Viton	14 x 1.78 (1 pc.)	
	Back-up ring	14.73 x 17.43 x 1.14 (1 pc.)	
Subplate size 04 (D 02)	Square ring - NBR 70	7.65 x 1.68 (4 pcs.)	20718400
Subplate size 06 (D 03)	Square ring - NBR 70	9.25 x 1.68 (4 pcs.)	15650300
Subplate size 04 (D 02)	O-ring - Viton	7.65 x 1.68 (4 pcs.)	28618000
Subplate size 06 (D 03)	O-ring - Viton	9.25 x 1.68 (4 pcs.)	28608100

Caution

- The packing foil is recyclable.
- The protecting plate can be returned to the manufacturer.
- Mounting studs must be ordered separately. Tightening torques are 5 Nm (size 04) and 8.9 Nm (size 06).
- The technical information regarding the product presented in this catalogue is for descriptive purposes only. It should not be construed in any case as a guaranteed representation of the product properties in the sense of the law.

ARGO-HYTOS s.r.o. CZ - 543 15 Vrchlabí

Tel.: +420-499-403111

e-mail: info.cz@argo-hytos.com





www.argo-hytos.com

Check Valves

2

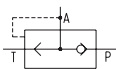
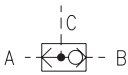
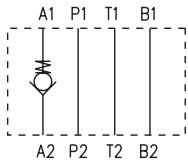
Check Valves

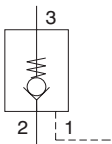
2

Symbol example	Flow l/min (GPM)	Pressure bar (PSI)	Type Code	Cartridge	NFPA D02, CETOP 2; NG4	NFPA D03, CETOP 3; NG6	NFPA D05, CETOP 5, NG10	Line Mounted	Page	Data Sheet
Logical 3 Way Check Valves										
	15 (4)	210 (3000)	VJL2-304	X					2.01	HA 5007
Logical Valves										
	8 (2)	500 (7300)	LV1-043		X				2.02	HA 5008
	40 (11)	320 (4600)	LV1-063			X			2.03	HA 5015
Check Valves										
	20 (5)	320 (4600)	VJO1-06/S	X					2.08	HA 5004
	30 (8)	320 (4600)	VJO1-04/M		X				2.09	HA 5012
	40 (11)	420 (6100)	SC1F-A2	X	(X)			(X)	2.06	HA 5010
	50 (13)	350 (5100)	MVJ3-06			X			2.10	HA 5018
	100 (26)	350 (5100)	MVJ3-10				X		2.11	HA 5020
	120 (32)	420 (6100)	SC1F-B2	X		(X)		(X)	2.07	HA 5017
	400 (106)	320 (4600)	VJ3					X	2.04	HA 5009
Check Valves, One-Way Throttling										
	250 (66)	320 (4600)	VJS3					X	2.05	HA 5019
Pilot Operated Check Valves Pilot to Open										
	20 (5)	250 (3600)	RJV1-05	X					2.16	HA 5111
	20 (5)	320 (4600)	VJR1-04/M		X				2.12	HA 5023
	30 (8)	350 (5100)	SC5H-Q3/I	X				(X)	2.17	HA 5217
	45 (12)	320 (4600)	VJR2-06/M			X			2.14	HA 5024
	60 (16)	320 (4600)	2RJV1-06			X			2.13	HA 5021
	90 (24)	350 (5100)	SC5H-R3/I	X				(X)	2.18	HA 5218
	90 (24)	350 (5100)	SCD5H-R3/I	X				(X)	2.19	HA 5219
	100 (26)	350 (5100)	VJR2-10/M				X		2.15	HA 5025
	120 (32)	350 (5100)	SC5H-S3/I	X				(X)	2.20	HA 5220
Pilot Operated Check Valves Pilot to Close										
	30 (8)	350 (5100)	SCC5H-Q3/I	X				(X)	2.21	HA 5221
	120 (32)	350 (5100)	SCC5H-S3/I	X				(X)	2.22	HA 5222

- Screw-in cartridge valve
- For leak-free applications
- Simple design
- High reliability

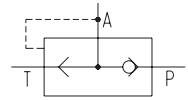

Functional Description

The fluid pressure in port P opens the ball check valve (1), thus allowing the fluid to pass to port A. Due to the area and pressure differential between ports P and A, the poppet (2) closes tightly the connection between ports A and T.

If there is no pressure in port P, then any pressure in port A causes the fluid to pass in the direction A → T. At the same time, the ball check valve provides a leak free closure between ports A and P.

The valve housing and the poppet are made of steel and hardened steel respectively.

The valve is delivered without any surface treatment.

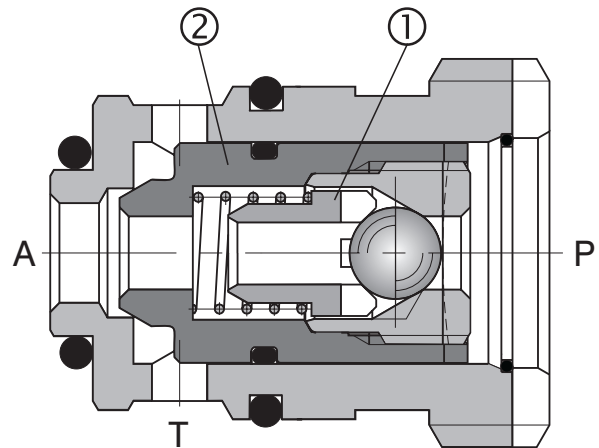

Ordering Code

VJL2 - 304 -

Shuttle Valve

3 way design

Valve size

no designation
V

Seals
Standard (NBR)
Viton (FPM)

M
G

Type of the connecting thread
Metric thread (M22x1.5)
Pipe thread (G1/2)

Spare Parts

Dimensions in millimeters

Seal kit		Dimensions, quantity		Ordering number
Type				
Standard NBR	O-ring	14 x 1.78 (1 pc.)		22737500
		9 x 1.8 (1 pc.)		
		10 x 1 (1 pc.)		
Viton		14 x 1.78 (1 pc.)		22737600
		9.25 x 1.78 (1 pc.)		
		10 x 1 (1 pc.)		

Technical Data

Valve size		04
Nominal flow rate P → A	L/min (GPM)	15 (4)
Nominal flow rate A → T	L/min (GPM)	15 (4)
Maximum working pressure	bar (PSI)	210 (3000)
Pressure drop	bar (PSI)	see the characteristic
Hydraulic fluid		Hydraulic oils of power classes (HL, HLP) to DIN 51524
Fluid temperature range (NBR)	°C (°F)	-30 ... +100 (-22 ... +212)
Fluid temperature range (Viton)	°C (°F)	-20 ... +120 (-4 ... +248)
Viscosity range	mm ² /s (SUS)	20 ... 400 (98 ... 1840)
Maximum degree of fluid contamination		Class 21/18/15 to ISO 4406
Weight	kg (lbs)	0.04 (0.088)
Mounting position		unrestricted

Δp-Q Characteristic

Measured at $v = 32 \text{ mm}^2/\text{s}$ (156 SUS)

Pressure drop Δp related to flow rate.

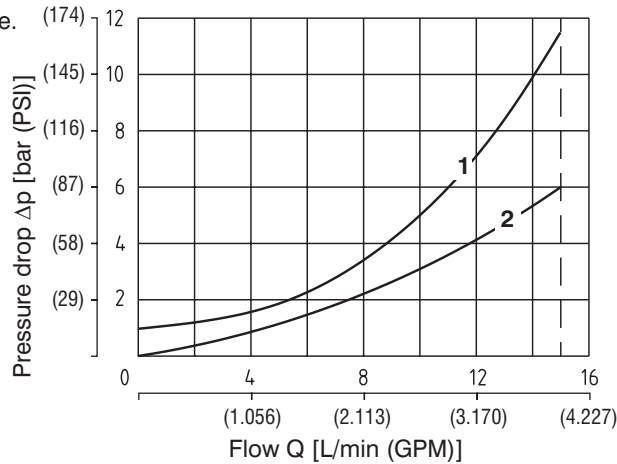

	Flow in direction
1	P → A
2	A → T

Valve Dimensions

Dimensions in millimeters (inches)

Valve Cavity

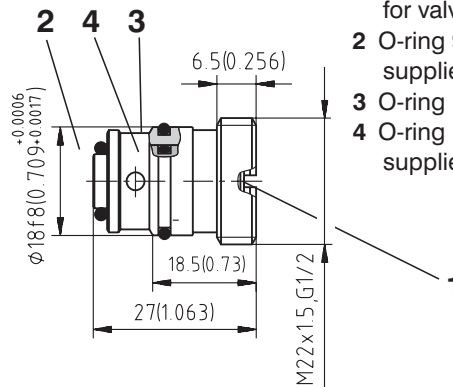
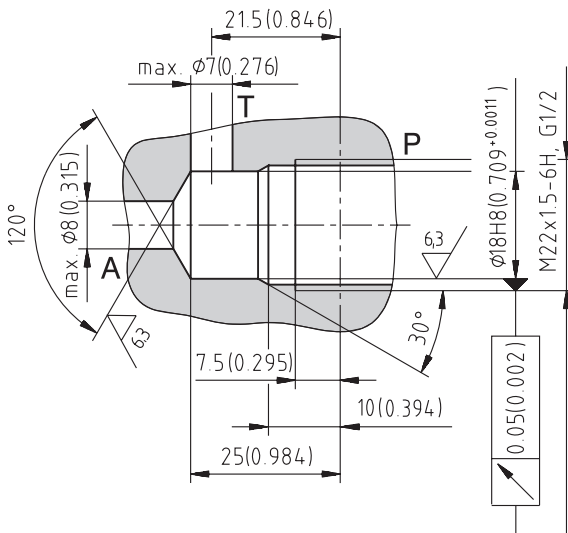

Dimensions in millimeters:

- 1 Screw driver slot for valve in cavity
- 2 O-ring 9 x 1.8 NBR70 (1 pc.), supplied with valve
- 3 O-ring 14 x 1.78
- 4 O-ring 10 x 1 (1 pc.), supplied with valve

Caution!

- The packing foil is recyclable.
- The technical information regarding the product presented in this catalogue is for descriptive purposes only. It should not be construed in any case as a guaranteed representation of the product properties in the sense of the law.

ARGO-HYTOS s.r.o. CZ - 543 15 Vrchlaví
 Tel.: +420-499-403111, Fax: +420-499-403421
 E-mail: sales.cz@argo-hytos.com
 www.argo-hytos.com

- Compact design
- Poppet design
- Comparing and transmitting a pressure signal

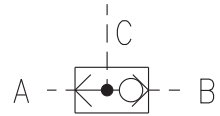

Functional Description

LV1-043 is 3 way poppet valve consists of the valve housing (1), the seat (3) and the ball (2).

It connects the users A or B with C according to the size of the control pressure in these ports.

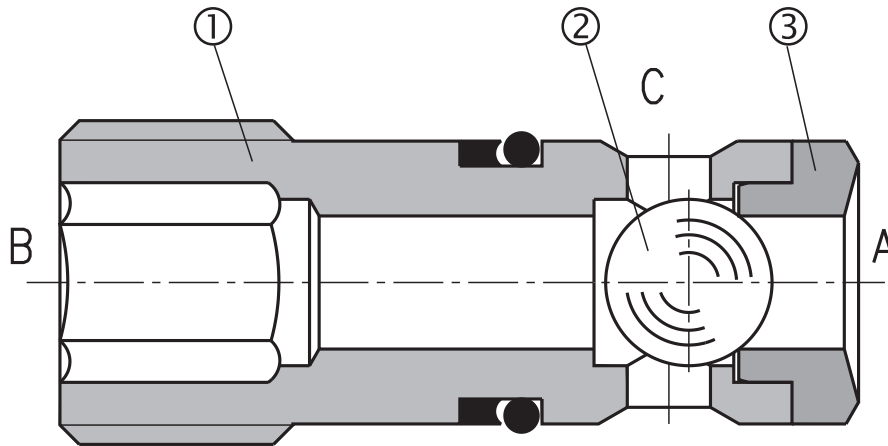

Ordering Code

LV1-043

Logical Valve

Nominal size

04

3 way design

Technical Data

Nominal size		04
Maximum flow rate	L/min (GPM)	8 (2.113)
Maximum working pressure	bar (PSI)	500 (7252)
Hydraulic fluid		Hydraulic oils of power classes (HL, HLP) to DIN 51524
Fluid temperature range (NBR)	°C (°F)	-30 ... +100 (-22... +212)
Viscosity range	mm ² /s (SUS)	20 ... 400 (98... 1840)
Maximum degree of fluid contamination		Class 21/18/15 to ISO 4406
Mounting position		unrestricted
Weight	kg (lbs)	0,01 (0.022)

Valve Dimensions

Dimensions in millimetres and inches

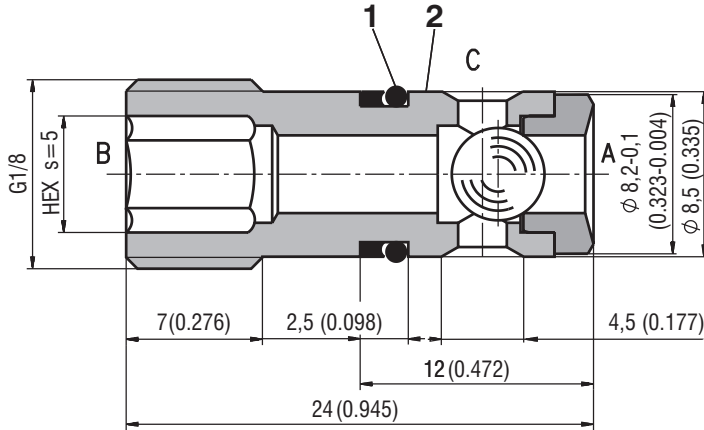

- 1 Thrust ring 8,5 x 6,8 x 1 (1 pc.)
- 2 O-ring 6 x 1 (1 pc.)
(supplied with valve)

Cavity

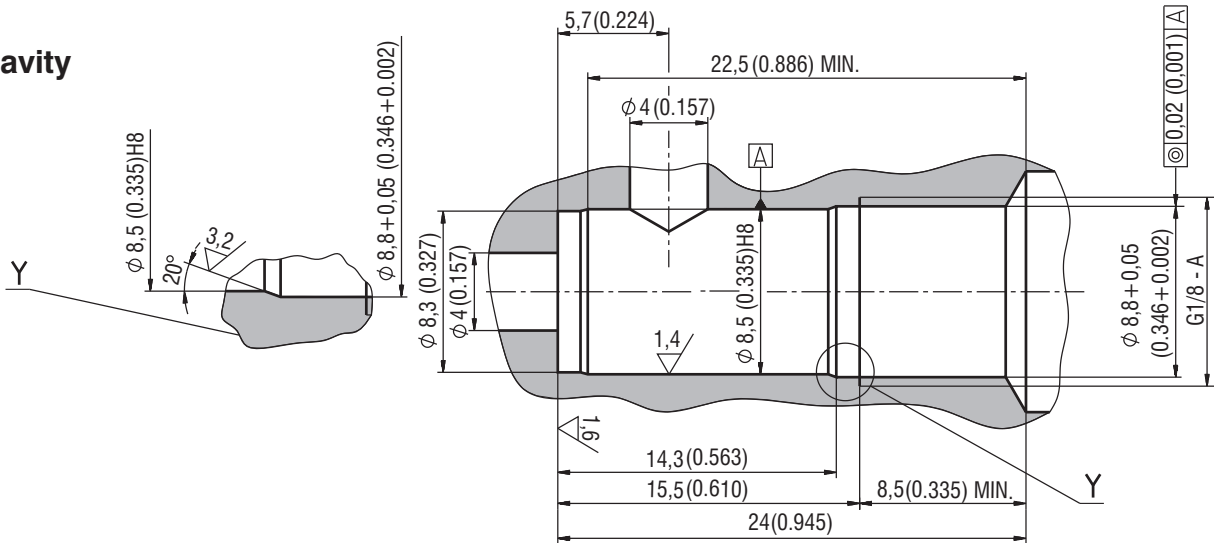

Spare Parts

Seal kit

Type	Dimensions, quantity	Ordering number
O-ring	6 x 1 (1 pc.)	16755700
Thrust ring	8,5 x 6,8 x 1 (1 pc.)	

Caution!

- The packing foil is recyclable.
- Tightening torque 12 Nm (8.85 lbf.ft).
- The technical information regarding the product presented in this catalogue is for descriptive purposes only. It should not be construed in any case as a guaranteed representation of the product properties in the sense of the law.

ARGO-HYTOS s.r.o. CZ - 543 15 Vrchlabí
 Tel.: +420-499-403111, Fax: +420-499-403421
 E-mail: sales.cz@argo-hytos.com
 www.argo-hytos.com

- Ball-valve
- Poppet design
- Comparing and transmitting a pressure signal

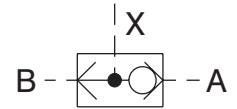
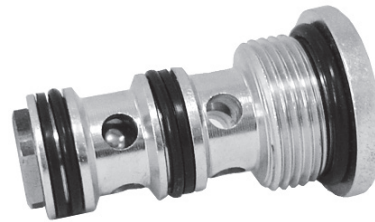

2

Functional Description

LV1-063 is 3 way poppet valve consists of the valve housing (1), the seat (3) and the ball (2). It connects the users B or A with X according to the size of the control signal in these ports.

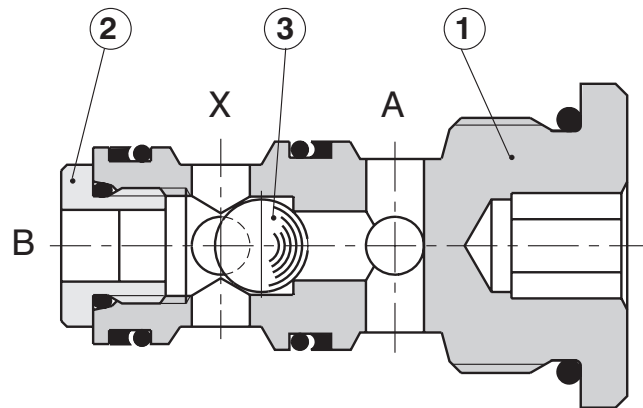

Ordering Code

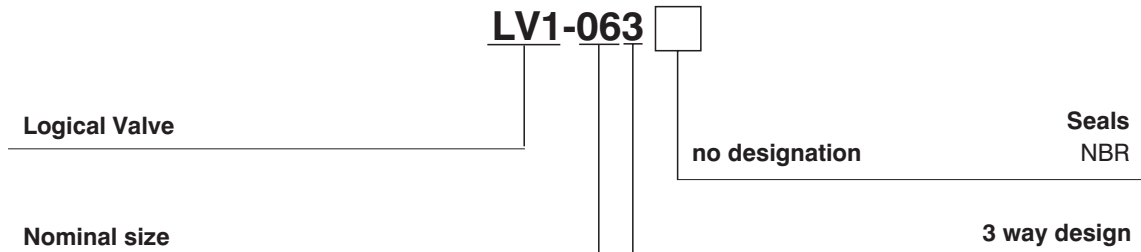

Technical Data

Nominal size		06
Maximum flow rate	L/min (GPM)	40 (10.57)
Maximum working pressure	bar(PSI)	320 (4641)
Fluid temperature range (NBR)	°F (°C)	-30 ... +100 (-22 ... +212)
Viscosity range	SUS (mm ² /s)	20 ... 400 (98 ... 1840)
Hydraulic fluid		Hydraulic oils of power classes (HL, HLP) to DIN 51524
Maximum degree of fluid contamination		Class 21/18/15 to ISO 4406
Mounting position		unrestricted
Weight	kg(lb)	0,078 (0.41)

Spare Parts

Seal kit			
Type	Dimensions, quantity		Ordering number
	O-ring	Back-up ring	
Standard - NBR	14 x 1.78 NBR 90 (2 pc.)	BBP80B015-N9 14.73 x 17.43 x 1.14 (2 pc.)	22752700
	19.4 x 2.1 NBR 80 (1 pc.)	-	

Δp-Q Characteristics

Measured at $v = 32 \text{ mm}^2/\text{s}$ (156 SUS)

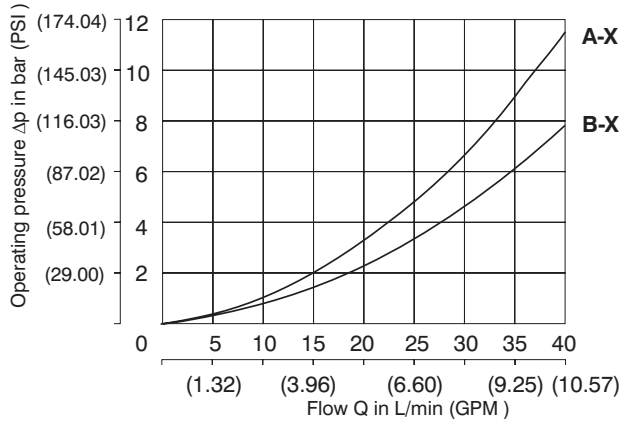

Valve Dimensions

Dimensions in inches and millimeters (in brackets)

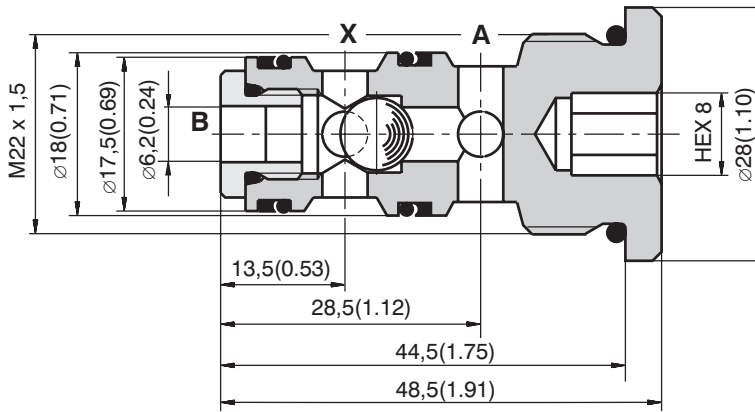

Cavity

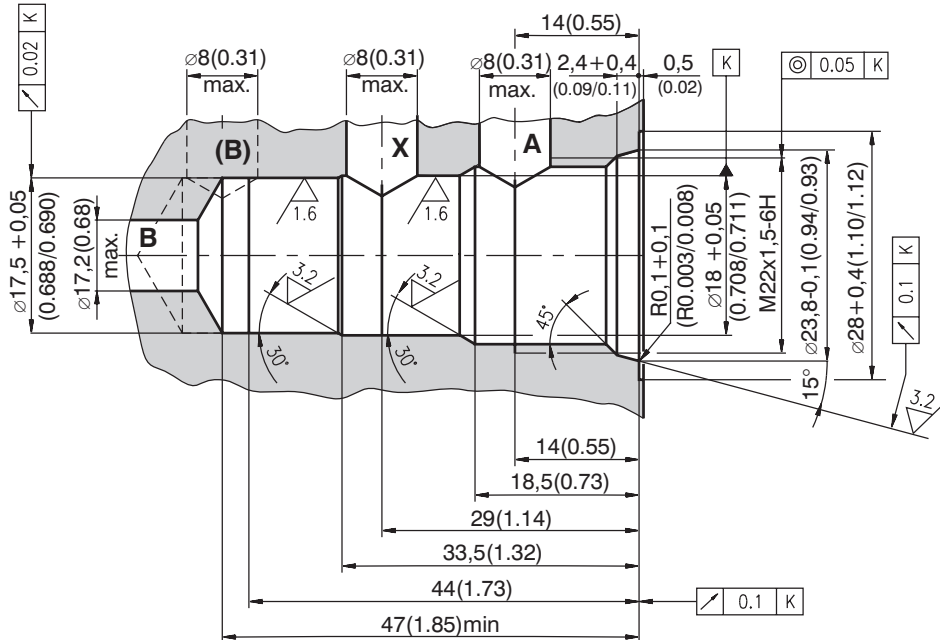

Caution!

- The packing foil is recyclable.
- Tightening torque 30 Nm.
- The technical information regarding the product presented in this catalogue is for descriptive purposes only. It should not be construed in any case as a guaranteed representation of the product properties in the sense of the law.

ARGO-HYTOS s.r.o. CZ - 543 15 Vrchlabí
 Tel.: +420-499-403111, Fax: +420-499-403421
 E-mail: sales.cz@argo-hytos.com
 www.argo-hytos.com

- Mounting styles:**
 - for in-line mounting
 - straight valve cartridge
 - right angled valve cartridge

- Seven sizes**

- Poppet design**

- Leakfree closure in one direction**

- Three cracking pressures**



Functional Description

The check valve is used to allow flow in one direction and prevent flow in the other. The poppet design guarantees leakfree closure.

The seat (3) is created directly in the housing (1) and the poppet (2) is pushed onto the seat by the compression spring (4). Design without spring pushes the poppet (2) on to the seat by pressure of the fluid. The cracking

pressure depends on the spring selected and the pressurised poppet surface area. Three cracking pressures are available. The valve without cracking pressure is also available (without spring).

The basic surface treatment of the valve housing is zinc coated.

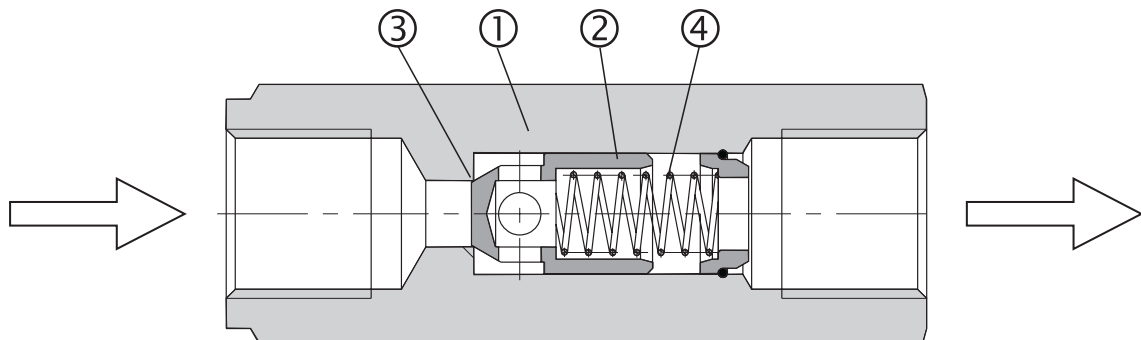

Ordering Code

VJ3 - <input type="checkbox"/> - <input type="checkbox"/> - <input type="checkbox"/>		
Check Valve		Model
		G1 For in-line mounting - with G threads
		M1* - with M threads
		S* - with SAE threads
		02* Straight valve cartridge
		03* Straight valve cartridge
		*For sizes 06, 10, 16, 20 only
Nominal size		Cracking pressure in bar
06	06	000 Without spring
08	08	005 0,5 bar (7.25 PSI)
10	10	015 1,5 bar (21.75 PSI)
16	16	030 3,0 bar (43.51 PSI)
20	20	
25	25	
30	30	

FOR PREFERRED TYPES SEE BOLD TYPING IN ORDERING CODE AND TABLE OF PREFERRED TYPES ON PAGE 4

Technical Data

Nominal size		06	08	10	16	20	25	30
Maximum flow rate	L/min (GPM)	30 (7.9)	40 (10.6)	60 (15.9)	160 (42.3)	250 (66)	300 (79.2)	400 (105.6)
Maximum pressure	bar(Psi)	320 (105.6)						
Cracking pressure	bar(Psi)	0,5 (7.25)		1,5 (21.75)		3,0 (43.51)		
Hydraulic fluid		Hydraulic oils of power classes (HL, HLP) to DIN 51524						
Fluid temperature range (NBR)	°C (°F)	-30 ... +100 (-22 ... +100)						
Viscosity range	mm ² /s (SUS)	20 ... 400 (98 ... 1840)						
Maximum degree of fluid contamination		Class 21/18/15 according to ISO 4406 (1999)						
Weight - model G1	kg (lbs)	0,11 (0.25)	0,2 (0.44)	0,34 (0.8)	0,52 (1.2)	0,95 (2.1)	1,95 (4.29)	2,35 (5.18)
- models M1, S	kg (lbs)	0,11 (0.25)	-	0,34 (0.8)	0,52 (1.2)	0,95 (2.1)	-	-
- models 02, 03	kg (lbs)	0,05 (0.002)	-	0,09 (0.004)	0,22 (0.009)	0,26 (0.010)	-	-
Mounting position		optional, in case of construction without spring						

Δp-Q Characteristics

Measured at v = 32 mm²/s (156 SUS)

Pressure drop Δp related to flow rate.

Nominal size 06

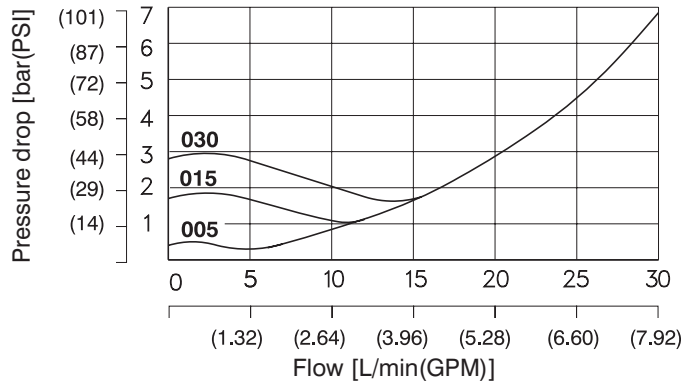

Nominal size 08

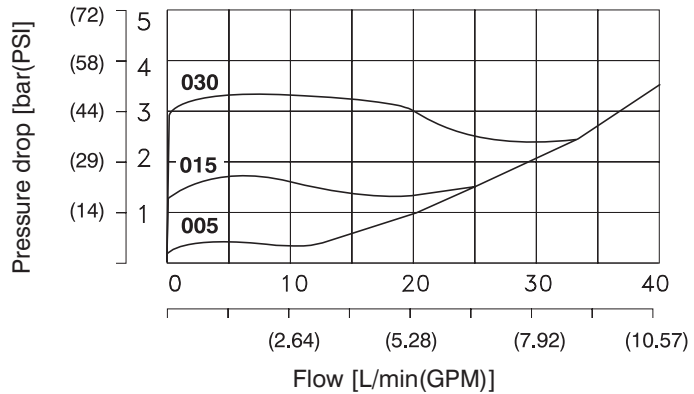

Nominal size 10

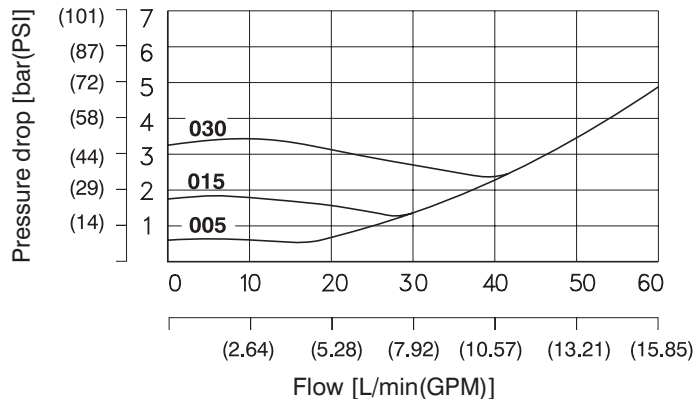

Δp-Q Characteristics

Measured at $v = 32 \text{ mm}^2/\text{s}$ (156 SUS)

Nominal size 16

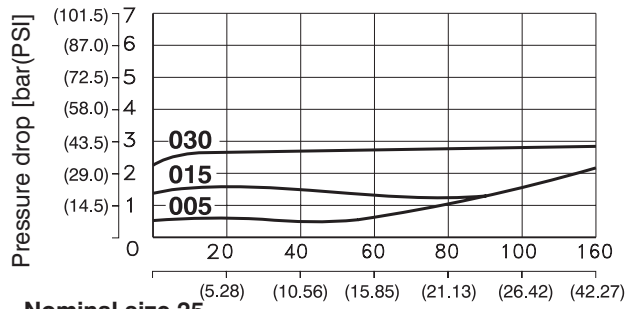

Nominal size 20

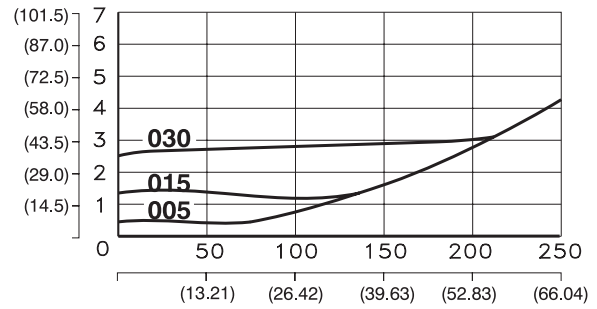

Nominal size 25

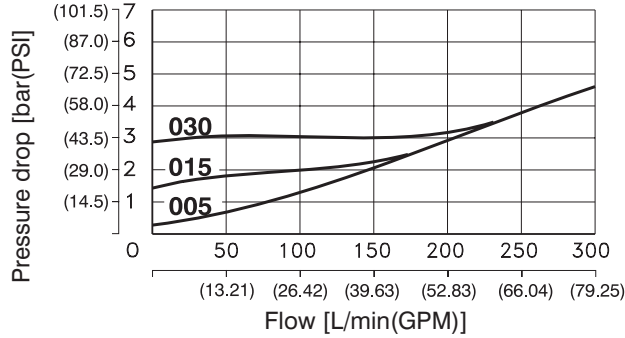

Nominal size 30

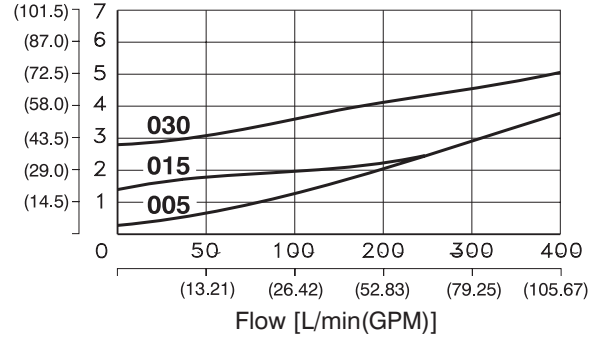

Valve Dimensions

Dimensions in millimeters (inches)

Model G1, M1, S

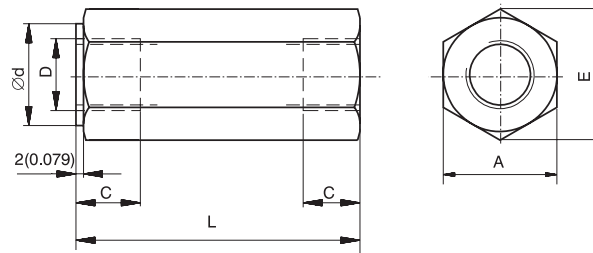

Model 02

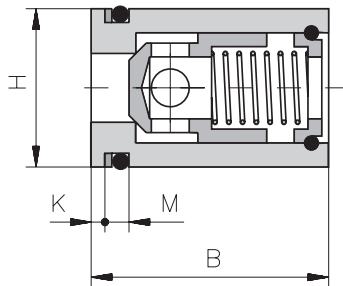

Model 03

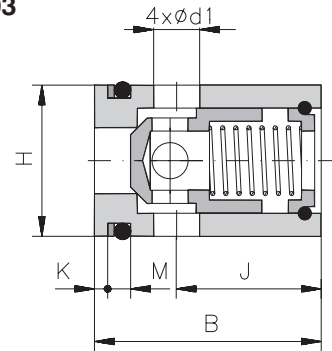

Size	A	B	C	D			Ød
				G1	M1	S	
06	19 (0.748)	27 - 0,2 (1.063-0.008)	12 (0.47)	G 1/4	M14x1,5	SAE-6, 9/16-18	19 (0.75)
08	24 (0.945)	-	12 (0.47)	G 3/8	-	-	24 (0.94)
10	30 (1.181)	32 - 0,2 (1.260-0.008)	14 (0.55)	G 1/2	M18x1,5	SAE-8, 3/4-16	30 (1.18)
16	36 (1.417)	45 - 0,2 (1.772-0.008)	16 (0.63)	G 3/4	M27x2	SAE-12, 1 1/16-12	36 (1.42)
20	46 (1.811)	45 - 0,2 (1.772-0.008)	18 (0.71)	G 1	M33x2	SAE-16, 1 5/16-12	46 (1.81)
25	60 (2.362)	-	20 (0.79)	G1 1/4	-	-	60 (2.36)
30	65 (2.559)	-	22 (0.87)	G1 1/2	-	-	65 (2.56)
Size	Ød1	E	H	J	K	L	M
06	3,5 (0.138)	22 (0.866)	Ø 20 (0.787 f8)	18 (0.709)	1,6 (0.063)	58 (2.28)	4,4 +0,2 (0.173+0.0079)
08	-	27,7 (1.09)	-	-	-	58 (2.28)	-
10	5,5 (0.217)	34,5 (1.358)	Ø 25 (0.984 f8)	20 (0.787)	1,6 (0.063)	72 (2.83)	4,4 +0,2 (0.173+0.0079)
16	8,5 (0.335)	41,5 (1.634)	Ø 35 (1.378 f8)	27 (1.063)	2,2 (0.087)	85 (3.35)	5,3 +0,2 (0.209+0.0079)
20	10,5 (0.413)	53,6 (2.087)	Ø 40 (1.575 f8)	25 (0.984)	2,2 (0.087)	98 (3.86)	5,3 +0,2 (0.209+0.0079)
25	-	69 (2.717)	-	-	-	120 (4.72)	-
30	-	75 (2.953)	-	-	-	132 (5.20)	-

Cavity

Dimensions in millimeters (inches)

(length according to distance ring)

Model 02

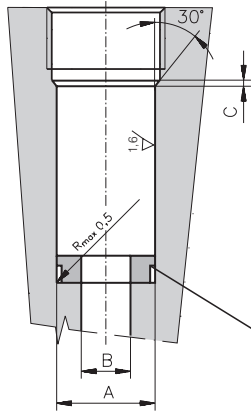

Model 03

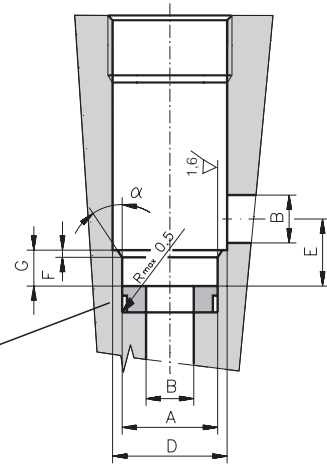

If the hole cannot be reamed to the bottom, the use of a distance ring is recommended

Size	A	B	C	D*	E	F	G	α
06	∅20 (0.787+0.0013 H8)	∅06 (0.236)	2 (0.079)	∅26 (1.024)	10.5 (0.413)	1 (0.039)	7-0.3 (0.276-0.0118)	20 °
10	∅25 (0.984+0.0013 H8)	∅10 (0.394)	2 (0.079)	∅32 (1.260)	14 (0.551)	1.5 (0.059)	8+0.2 (0.315+0.0079)	30 °
16	∅35 (1.378+0.0015 H8)	∅16 (0.630)	2 (0.079)	∅44 (1.732)	22 (0.866)	2 (0.079)	13+0.2 (0.512+0.0079)	30 °
20	∅40 (1.575+0.0015 H8)	∅20 (0.787)	2 (0.079)	∅48 (1.890)	25 (0.984)	2 (0.079)	14+0.2 (0.551+0.0079)	30 °

* minimum diameter recommended

SAE-Port Cavities

Dimensions in millimeters (inches)

Type	Thread size	∅D1	L1	L2	Z°
SAE-6	9/16-18 UNF-2B	15.6 (0.614)	2.5 (0.098)	13 (0.512)	12
SAE-8	3/4-16 UNF-2B	20.6 (0.811)	2.5 (0.098)	15 (0.591)	15
SAE-12	1 1/16-12 UN-2B	29.2 (1.150)	2.5 (0.098)	19 (0.748)	15
SAE-16	1 5/16-12 UN-2B	35.5 (1.398)	3.3 (0.130)	19 (0.748)	15

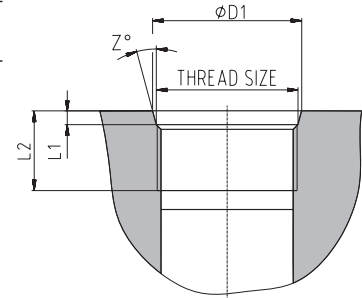

Spare Parts

Seal kit for Model 02 and Model 03

Size	O-Ring - NBR	Back-up ring	Order number
06	15,08 x 2,62	BBP 80B113-N9 14,66 x 19,02 x 1,14	22701100
10	20 x 2,65	BBP 80B116-N962N 19,43 x 23,79 x 1,14	15954600
16	28 x 3,55	BBP 80B216-N9 8,98 x 34,98 x 1,02	15954700
20	32,92x3,53	BBP 80B219-N90 33,88 x 39,88 x 1,02	22701400

Preferred Types of Valves

Typ	Order number	Typ	Order number
VJ3-06-005-M1	28433500	VJ3-06-005-G1	15946400
-	-	VJ3-08-005-G1	22666100
VJ3-10-005-M1	28433800	VJ3-10-005-G1	17333500
VJ3-16-005-M1	28434100	VJ3-16-005-G1	22663600
VJ3-20-005-M1	28434400	VJ3-20-005-G1	17333700
-	-	VJ3-25-005-G1	22664200
-	-	VJ3-30-005-G1	22665000

Caution!

- The packing foil is recyclable.
- The technical information regarding the product presented in this catalogue is for descriptive purposes only. It should not be construed in any case as a guaranteed representation of the product properties in the sense of the law.

ARGO-HYTOS s.r.o. CZ - 543 15 Vrchlaví
 Tel.: +420-499-403111, Fax: +420-499-403421
 E-mail: sales.cz@argo-hytos.com
 www.argo-hytos.com

- Mounting styles:**
 - for in-line mounting
 - straight valve cartridge
 - right angled valve cartridge
- Four sizes**
- Poppet design**
- One-way throttling check valve**
- Three cracking pressures**

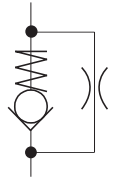

Functional Description

Check valves are used to allow flow in one direction and prevent flow in the other. The poppet design guarantees leak free closure and so it is allowed throttling only through orifice plate (5). The seat (3) is created directly in the housing (1) and the poppet (2) is pushed onto the seat by the compression spring (4). Design without spring pushes the poppet (2) on to the seat by pressure

of the fluid. The cracking pressure depends on the spring selected and the pressurised poppet surface area. Three cracking pressures are available. The valve without cracking pressure is also available (without spring). The basic surface treatment of the valve housing is zinc coated.

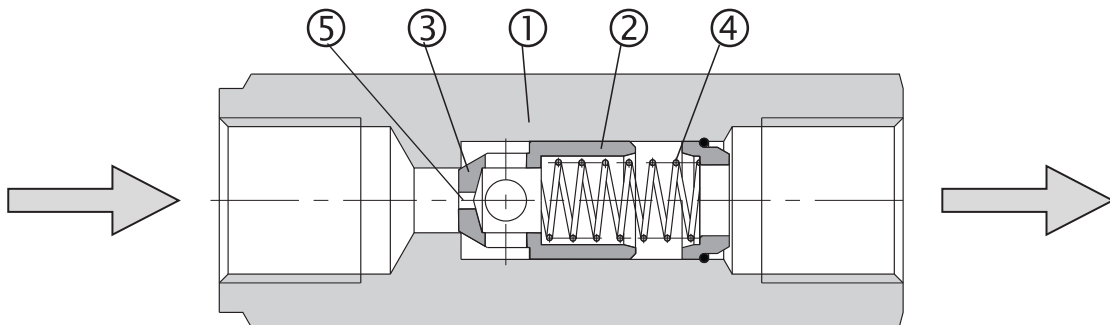

Ordering Code

VJS3 - [] - [] - [] - []		Orifice average	
Check Valve		020	0,20 mm (0,008 inch)
		050	0,50 mm (0,019 inch)
		080	0,80 mm (0,031 inch)
		100	1,00 mm (0,039 inch)
		150	1,50 mm (0,059 inch)
		200	2,00 mm (0,079 inch)
		300	3,00 mm (0,118 inch)
			Other orifices on demand
Nominal size		G1	Model
06	06	M1	For in-line mounting - with G threads
10	10	S	- with M threads
16	16	02	- with SAE threads
20	20	03	Straight valve cartridge
			Straight valve cartridge
Cracking pressure			
Without spring	000		
0,5 bar (7.25 PSI)	005		
1,5 bar (21.75 PSI)	015		
3,0 bar (43.51 PSI)	030		

Technical Data

Nominal size		06	10	16	20
Maximum flow rate	L/min (GPM)	30 (7.9)	60 (15.9)	160 (42.3)	250 (66)
Maximum pressure	bar (PSI)	320 (4600)			
Cracking pressure	bar (PSI)	0,5 (7.25)	1,5 (21.75)	3,0 (43.51)	
Hydraulic fluid		Hydraulic oils of power classes (HL, HLP) to DIN 51524			
Fluid temperature range (NBR)	°C (°F)	-30 ... +100 (-22 ... +100)			
Viscosity range	mm ² /s (SUS)	20 ... 400 (98 ... 1840)			
Maximum degree of fluid contamination		Class 21/18/15 according to ISO 4406			
Weight - model G1,M1,S - models 02, 03	kg (lbs)	0.11 (0.25) 0.05 (0.002)	0.34 (0.8) 0.09 (0.004)	0.52 (1.2) 0.22 (0.009)	0.95 (2.1) 0,26 (0.010)
Mounting position		unrestricted, in case of construction without spring			

Δp-Q Characteristics

Measured at v = 32 mm²/s (156 SUS)

Pressure drop Δp related to flow rate.

Nominal size 06

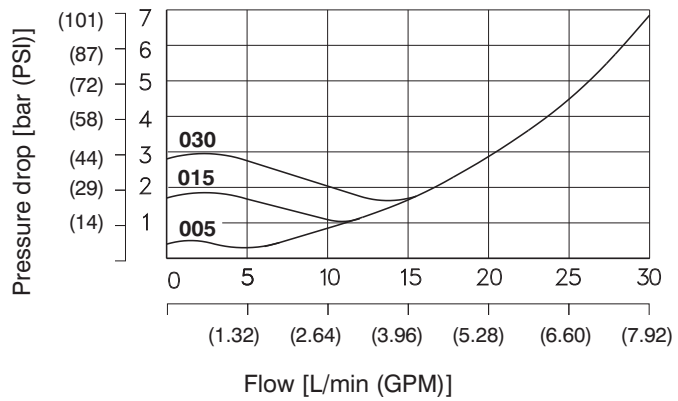

Nominal size 10

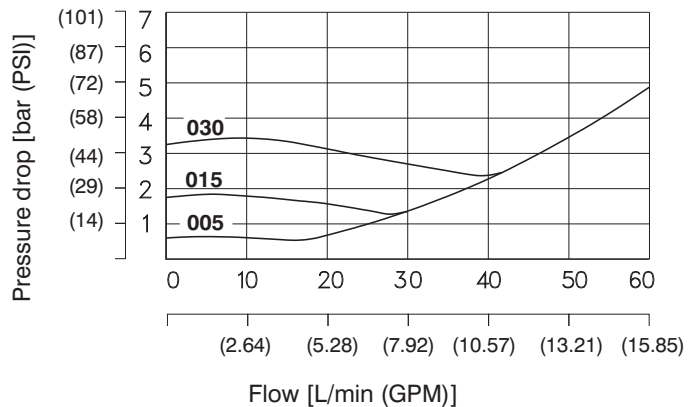

Δp-Q Characteristics

Measured at $v = 32 \text{ mm}^2/\text{s}$ (156 SUS)

Nominal size 16

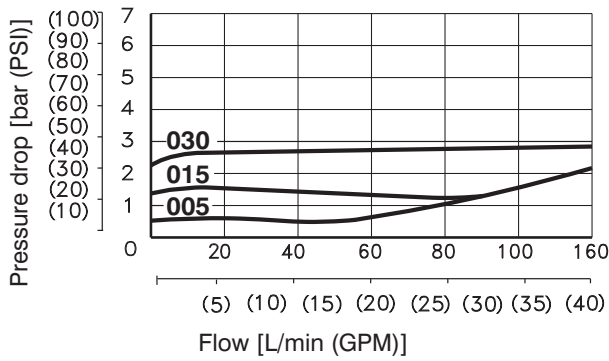

Nominal size 20

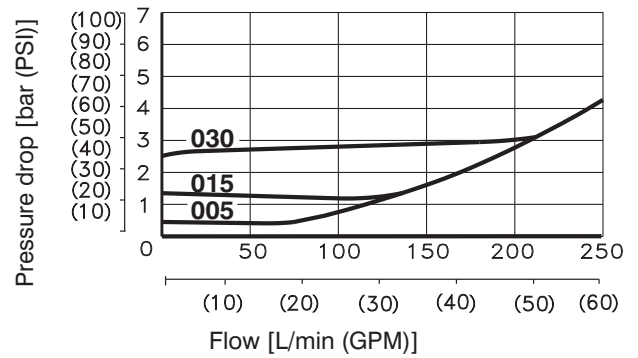

Valve Dimensions

Dimensions in millimeters (inches)

Model G1

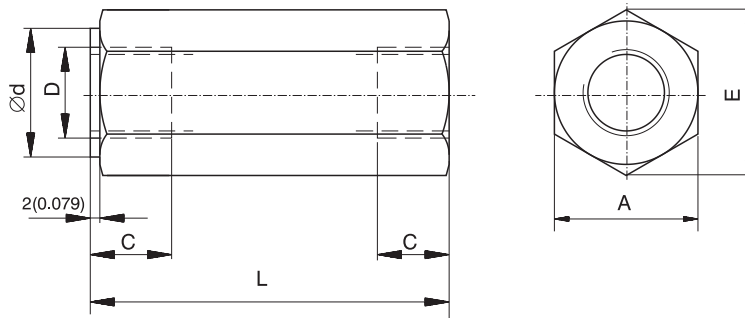

Model 02

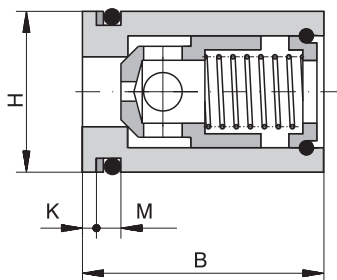

Model 03

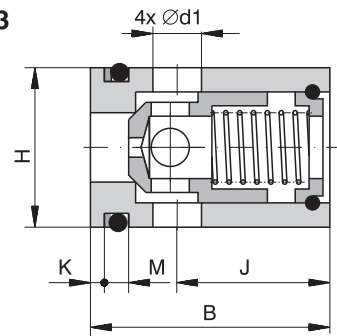

Size	A	B	C	D			Ød
				G1	M1	S	
06	19 (0.748)	27 - 0,2 (1.063-0.008)	12 (0.47)	G 1/4	M14x1,5	SAE-6, 9/16-18	19 (0.75)
10	30 (1.181)	32 - 0,2 (1.260-0.008)	14 (0.55)	G 1/2	M18x1,5	SAE-8, 3/4-16	30 (1.18)
16	36 (1.417)	45 - 0,2 (1.772-0.008)	16 (0.63)	G 3/4	M27x2	SAE-12, 1 1/16-12	36 (1.42)
20	46 (1.811)	45 - 0,2 (1.772-0.008)	18 (0.71)	G 1	M33x2	SAE-16, 1 5/16-12	46 (1.81)
Size	E	H	J	K	L	M	
06	22 (0.866)	Ø20 (0.787) f8	18 (0.709)	1.6 (0.063)	58 (2.28)	4.4+0.2 (0.173+0.0079)	
10	34.5 (1.358)	Ø25 (0.984) f8	20 (0.787)	1.6 (0.063)	72 (2.83)	4.4+0.2 (0.173+0.0079)	
16	41.5 (1.634)	Ø35 (1.378) f8	27 (1.063)	2.2 (0.087)	85 (3.35)	5.3+0.2 (0.209+0.0079)	
20	53 (2.087)	Ø40 (1.575) f8	25 (0.984)	2.2 (0.087)	98 (3.86)	5.3+0.2 (0.209+0.0079)	

Cavity

Dimensions in millimeters (inches)

(length according to distance ring)

Model 02

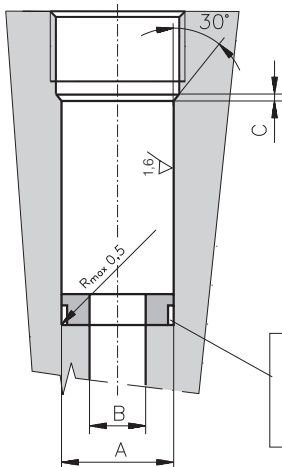

Model 03

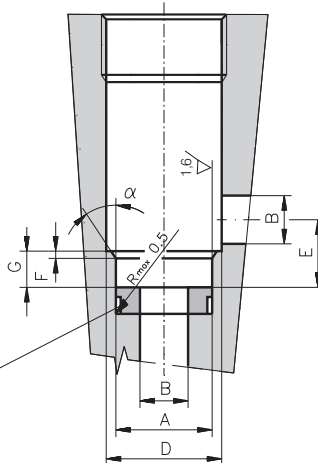

If the hole cannot be reamed to the bottom, the use of a distance ring is recommended.

Size	A	B	C	D*	E	F	G	α
06	∅20 (0.787+0.0013) H8	∅06 (0.236)	2 (0.079)	∅26 (1.024)	10.5 (0.413)	1 (0.039)	7-0.3 (0.276-0.0118)	20 °
10	∅25 (0.984+0.0013) H8	∅10 (0.394)	2 (0.079)	∅32 (1.260)	14 (0.551)	1.5 (0.059)	8+0.2 (0.315+0.0079)	30 °
16	∅35 (1.378+0.0015) H8	∅16 (0.630)	2 (0.079)	∅44 (1.732)	22 (0.866)	2 (0.079)	13+0.2 (0.512+0.0079)	30 °
20	∅40 (1.575+0.0015) H8	∅20 (0.787)	2 (0.079)	∅48 (1.890)	25 (0.984)	2 (0.079)	14+0.2 (0.551+0.0079)	30 °

SAE-Port Cavities

Dimensions in millimeters (inches)

ISO 11926, SAE J1926, MS 16142

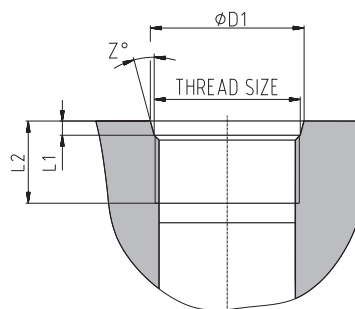

Type	Thread size	∅D1	L1	L2	Z°
SAE-6	9/16-18 UNF-2B	15.6 (0.614)	2.5 (0.098)	13 (0.512)	12
SAE-8	3/4-16 UNF-2B	20.6 (0.811)	2.5 (0.098)	15 (0.591)	15
SAE-12	1 1/16-12 UN-2B	29.2 (1.150)	2.5 (0.098)	19 (0.748)	15
SAE-16	1 5/16-12 UN-2B	35.5 (1.398)	3.3 (0.130)	19 (0.748)	15

Spare Parts

Seal kit for Model 02 and Model 03

Size	O-Ring - NBR	Back-up ring	Ordering number
06	15,08 x 2,62	BBP 80B113-N9 14,66 x 19,02 x 1,14	22701100
10	20 x 2,65	BBP 80B116-N962N 19,43 x 23,79 x 1,14	15954600
16	28 x 3,55	BBP 80B216-N9 8,98 x 34,98 x 1,02	15954700
20	32,92x3,53	BBP 80B219-N90 33,88 x 39,88 x 1,02	22701400

Caution!

- The packing foil is recyclable.
- The technical information regarding the product presented in this catalogue is for descriptive purposes only. It should not be construed in any case as a guaranteed representation of the product properties in the sense of the law.

ARGO-HYTOS s.r.o. CZ - 543 15 Vrchlabí
 Tel.: +420-499-403111, Fax: +420-499-403421
 E-mail: sales.cz@argo-hytos.com
 www.argo-hytos.com

- Standard and High performance variant
- Poppet design
- Leakfree closure in one direction
- Four cracking pressures



Functional Description

The check valve serves the leak free closure in one direction and allows flow in the opposite direction. The poppet design provides leak free closure.

The seat is created directly in the valve housing (1) and the small ball (2) is pushed by spring (3) through the thumb ring (4)* onto the seat. The cracking pressure depends on the spring selected, its preloading and the

pressurized poppet surface area. The cracking pressure with a standard valve is 0.5 bar (7.25 PSI). Four* cracking pressures are available.

The surface of the valve housing is zinc coated.

* With the High performance valve

Cartridge Valve

Standard performance

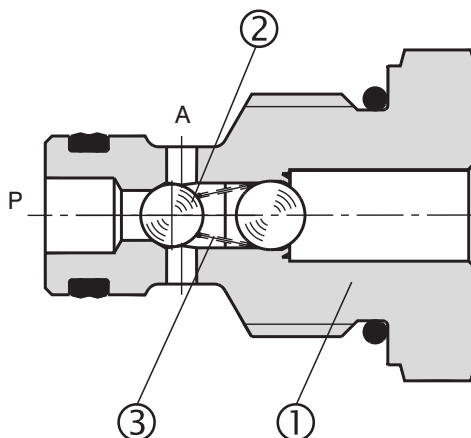

High performance

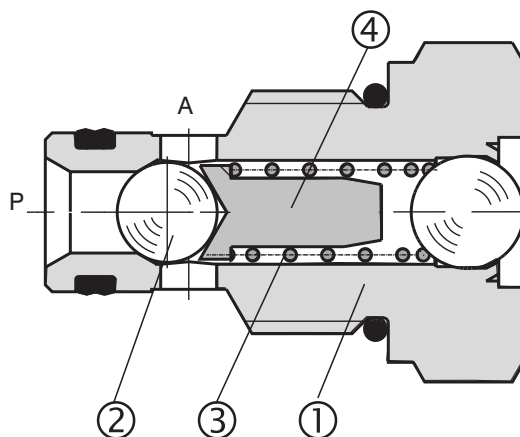

Ordering Code

SC1F-A2 /

Check Valves - 3/4 16 UNF

no designation
V

Standard
High performance

S
H

***005**
015
035
070

Seals
NBR
FPM (Viton)

Cracking pressure
0.5 bar (7.2 PSI)
1.5 bar (21.7 PSI)
3.5 bar (50.7 PSI)
7.0 bar (101.5 PSI)

* The cracking pressure with a standard valve is 0.5 bar (7.25 PSI)

Technical Data

		Standard	High performance
Cartridge thread		3/4 16 UNF-2A	
Maximum flow rate	L/min (GPM)	20 (5.3)	40 (10.6)
Max. operating pressure	bar (PSI)	350 (5076)	420 (6091)
Cracking pressure	bar (PSI)	0,5* 1,5	3,5 7,0
Hydraulic fluid		Hydraulic oils of power classes (HL, HLP) to DIN 51524	
Fluid temperature range (NBR)	°C (°F)	-30 +100 (-22 ... +212)	
Fluid temperature range (Viton)	°C (°F)	-20 +120 (-4 ... +248)	
Viscosity range	mm ² /s (SUS)	10 ... 500 (49 ... 2450)	
Maximum degree of fluid contamination		Class 21/18/15 according to ISO 4406	
Valve tightening torque	Nm (lbf.ft)	60+2 (44.25+1.47)	
Weight	kg(lbs)	0,05	0,06
Mounting position		unrestricted	
Valve body (data sheed HA 0018)		SB-A2	

* The cracking pressure with a standard valve is 0.5 bar (7.25 PSI)

Δp-Q Characteristics

Measured at v = 32 mm²/s (156 SUS)

Standard valve

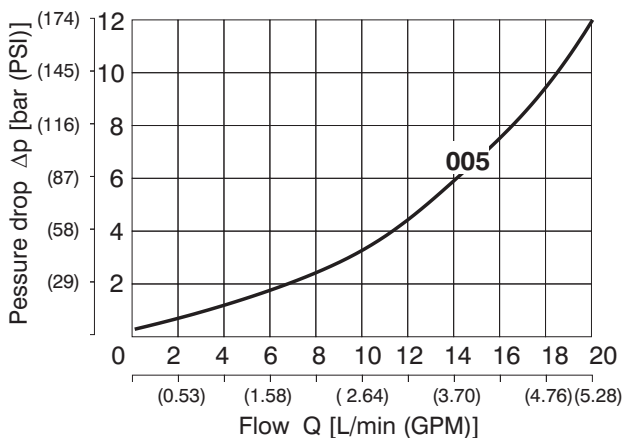

High performance valve

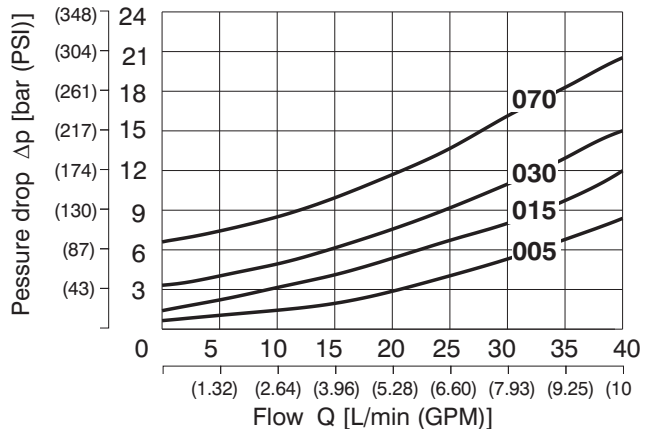

Valve Dimensions

Dimensions in millimeters (inches)

Standard valve

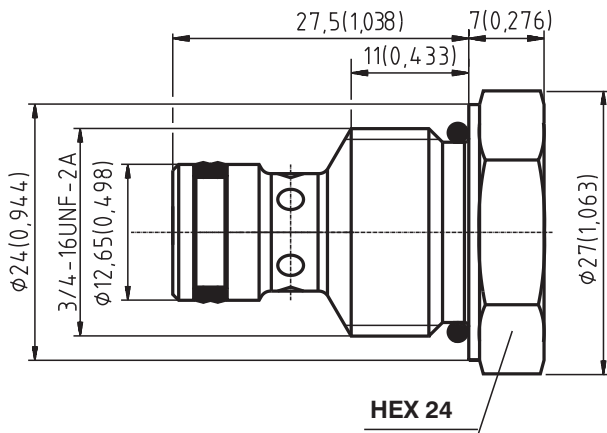

High performance valve

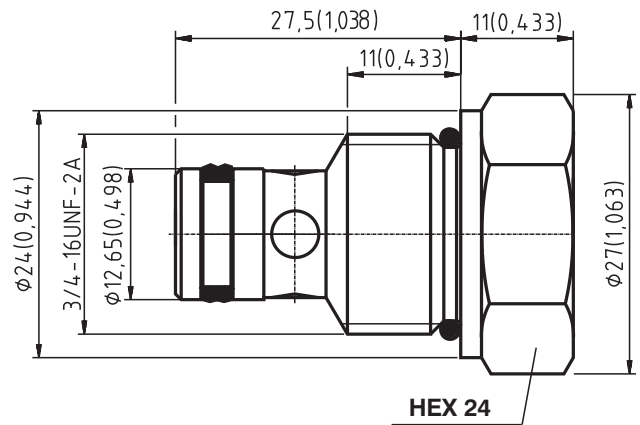

Cavity

Dimensions in millimeters (inches)

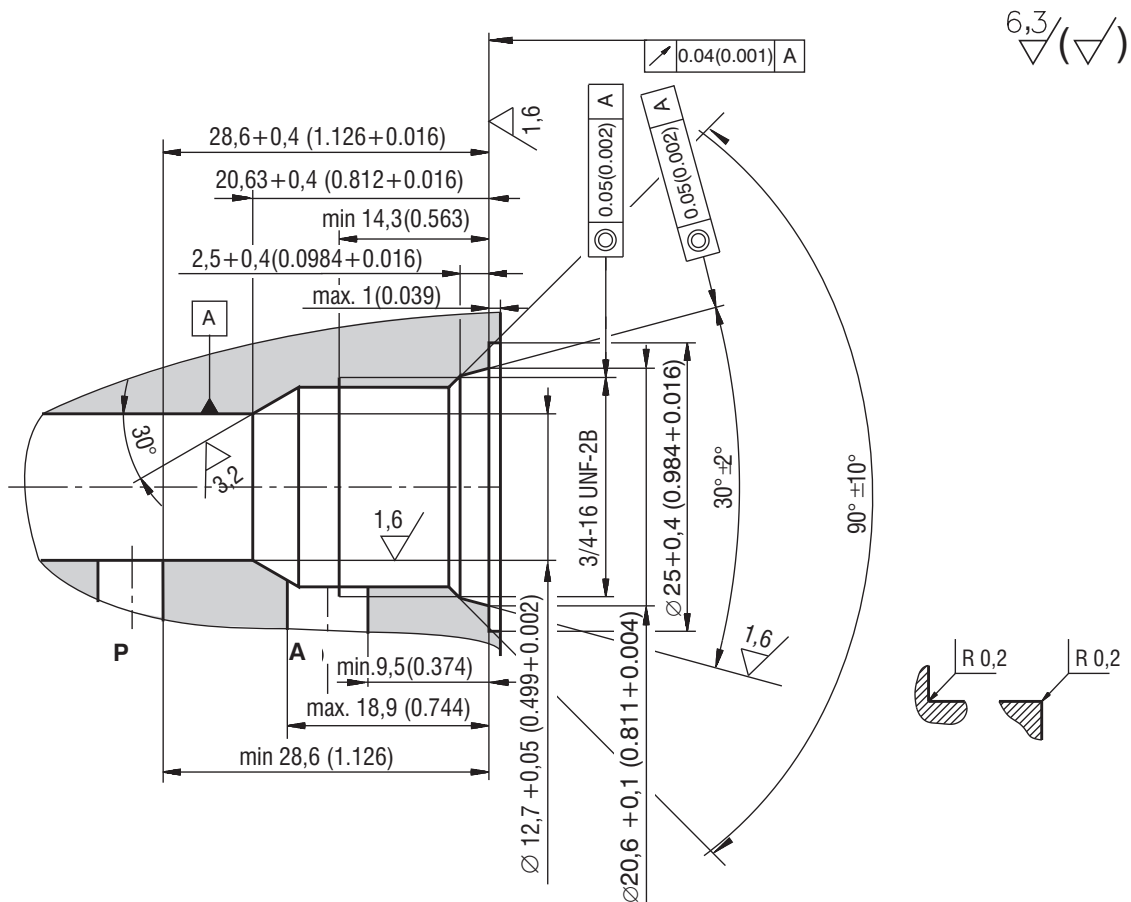

Spare Parts

Standard and high performance valve

Dualeal - PU	O-ring - NBR	O-ring - Viton	Ordering number
10.3 x 12.7 x 3.1 (1pc.)	17 x 1.8 (1pc.)	-	22752500
10.3 x 12.7 x 3.1 (1pc.)	-	17.17 x 1.78 (1pc.)	22752600

Caution!

- The packing foil is recyclable.
- The technical information regarding the product presented in this catalogue is for descriptive purposes only. It should not be construed in any case as a guaranteed representation of the product properties in the sense of the law.

ARGO-HYTOS s.r.o. CZ - 543 15 Vrchlabí
Tel.: +420-499-403 111
E-mail: info.cz@argo-hytos.com
www.argo-hytos.com

- Poppet design
- Leakfree closure in one direction
- Four cracking pressures

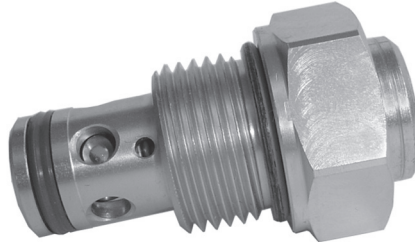

Functional Description

The check valve serves the leak free closure in one direction and allows flow in the opposite direction. The poppet design provides leak free closure.

The seat is created directly in the valve housing (1) and the small ball (2) is pushed by spring (3) through the thumb ring (4)* onto the seat. The cracking pressure depends on the spring selected, its preloading and the

pressurized poppet surface area. Four* cracking pressures are available.

The surface of the valve housing is zinc coated.

* With the High performance valve

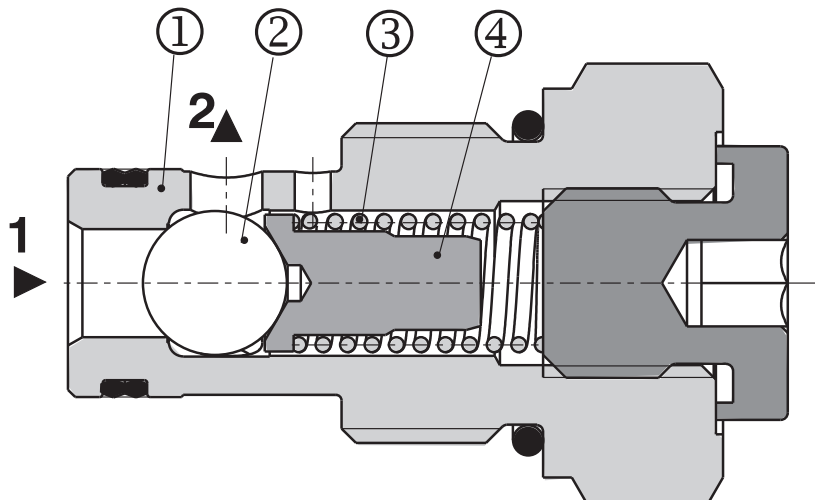

Ordering Code

SC1F-B2 /



no designation
V

Seals
NBR
FPM (Viton)

Check valves - 7/8 14UNF

High performance

H

005
015
035
050
070

Cracking pressure
0,5 bar (7.2 PSI)
1,5 bar (21.7 PSI)
3,5 bar (50.7 PSI)
5,0 bar (71,5 PSI)
7,0 bar (101.5 PSI)

Technical Data

		High performance
Cartridge thread		7/8 14UNF-2A
Maximum flow rate	L/min (GPM)	120 (31.7)
Max. operating pressure	bar (PSI)	420 (6091)
Cracking pressure	bar (PSI)	0,5 (7.2) 1,5 (21.7) 3,5 (50.7) 5,0 (71.5) 7,0 (101.5)
Hydraulic fluid		Hydraulic oils of power classes (HL, HLP) to DIN 51524
Fluid temperature range (NBR)	°C (°F)	-30 ... +100 (-22 ... +212)
Fluid temperature range (Viton)	°C (°F)	-20 ... +120 (-4 ... +248)
Viscosity range	mm ² /s (SUS)	10 ... 500 (49 ... 2450)
Maximum degree of fluid contamination		Class 21/18/15 according to ISO 4406
Valve tightening torque	Nm (lbf.ft)	60 +2 (44.25 +1.47)
Weight	kg(lbs)	0,12
Mounting position		unrestricted
Valve body (data sheet HA 0018)		SB-B2

Δp-Q Characteristics

Measured at v = 32 mm²/s (156 SUS)

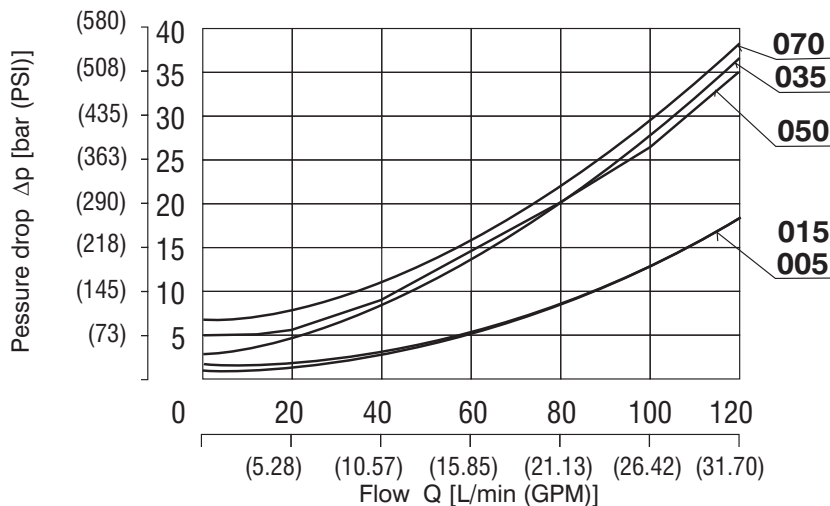

Valve Dimensions

Dimensions in millimeters (inches)

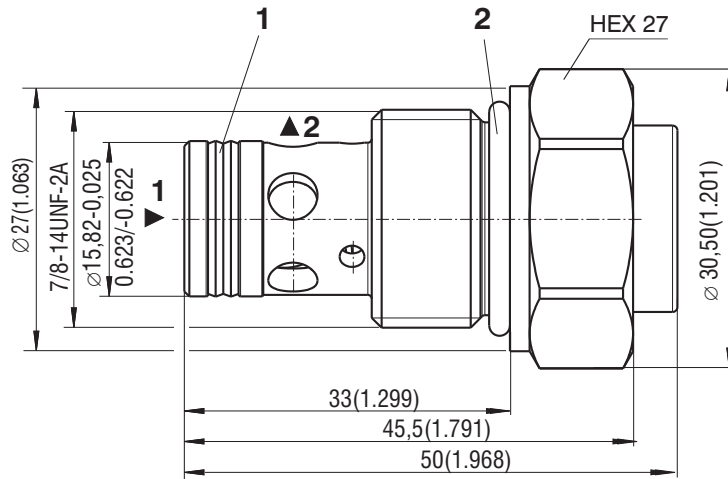

- 1 Combined sealing:
DRYZ000002Z20 13,47 x 15,87 x 3,1 (supplied with valve)
- 2 O-ring 19,4 x 2,1 (supplied with valve)

Cavity

Dimensions in millimeters (inches)

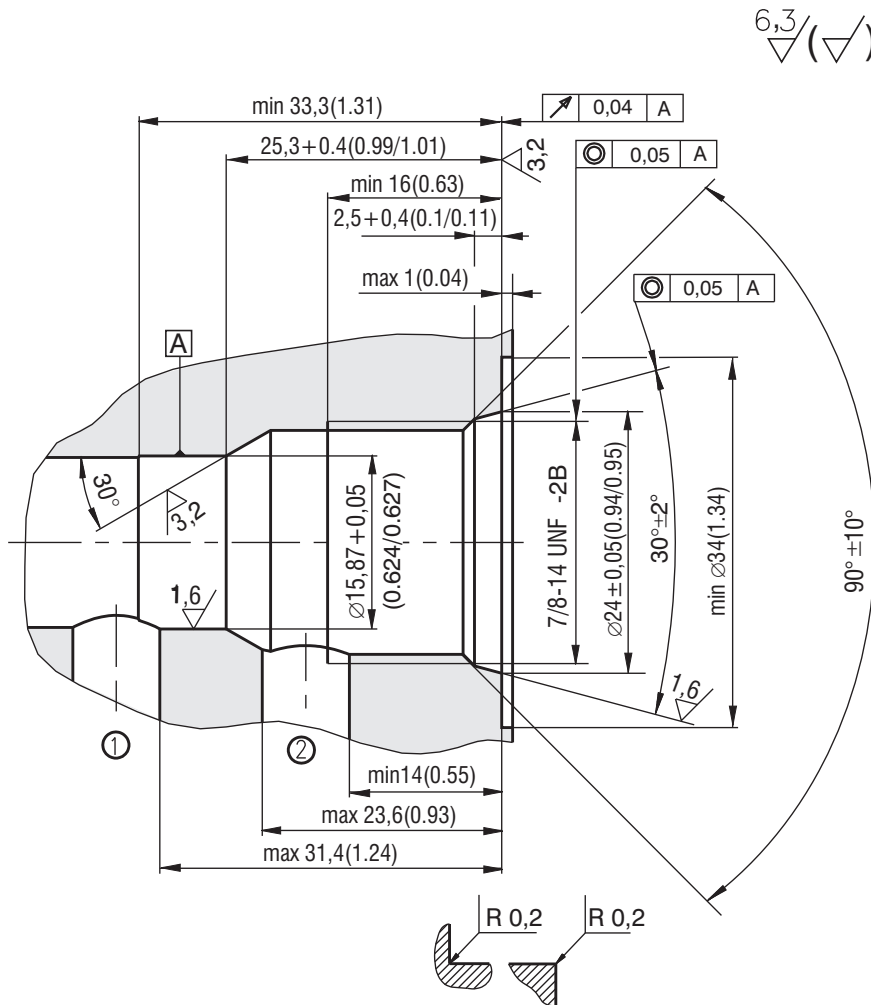

Spare Parts

Seal kit		Ordering number
Dualseal - PU	O-ring - NBR	18775600
DRYZ000002Z20 13,47 x 15,87 x 3,1 (1pc.)	19,4 x 2,1 (1pc.)	

Caution!

- The packing foil is recyclable.
- The technical information regarding the product presented in this catalogue is for descriptive purposes only. It should not be construed in any case as a guaranteed representation of the product properties in the sense of the law.

ARGO-HYTOS s.r.o. CZ - 543 15 Vrchlabí
Tel.: +420-499-403 111
E-mail: info.cz@argo-hytos.com
www.argo-hytos.com

- Small dimensions
- Two models
- Poppet design
- Leak-free closure in one direction



VJO1-06/Sx-1



VJO1-06/Sx-2

Functional Description

The check valves VJO1 are developed to be built directly into the lines of the hydraulic circuits. Their features designate them for all applications, where tight closure in one direction and small dimensions are required. The valve is provided with holes for a mounting mandrel. The shut-off edge (3) of the valve is engineered in the housing (1) and the shut-off function is

accomplished by the ball (2) which is pushed onto the seat by spring (4). Sealing of the valve body (1) in the mounting cavity is provided by the sealing ring (5). During the assembly, the valve has to be secured against loosening by means of a suitable glue or cement (Loctite, etc.).

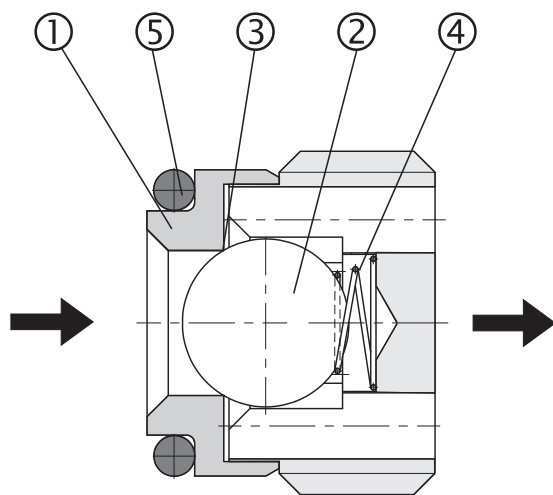

Model 01

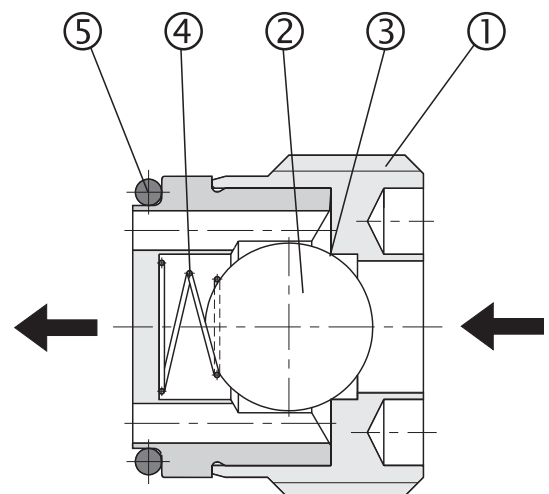

Model 02

Ordering Code

VJO1-06/S -

Check Valve

Valve size

Cartridge

S

G
S

no designation
V

Seals
NBR
FPM (Viton)

Flow direction
model 01
model 02

Model
pipe thread G1/4
thread SAE

1
2

Technical Data

Valve size		06
Maximum flow rate	L/min (GPM)	20 (5.28)
Maximum operating pressure	bar (PSI)	320 (4600)
Cracking pressure	bar (PSI)	0,25 (3.62)
Hydraulic fluid		Petroleum oils (HM, HL, HLP)
Fluid temperature range for (NBR)	°C (°F)	-30 ... +100 (-22 ... +212)
Fluid temperature range for (Viton)	°C (°F)	-20 ... +120 (-4 ... +248)
Viscosity range	mm ² /s (SUS)	20 ... 400 (98 ... 1840)
Maximum degree of fluid contamination		Class 21/18/15 to ISO 4406
Weight	kg (lbs)	0.007 (0.015)
Mounting position		unrestricted

Δp-Q Characteristics

Measured at $v = 32 \text{ mm}^2/\text{s}$ (156 SUS)

Pressure drop Δp related to flow rate.

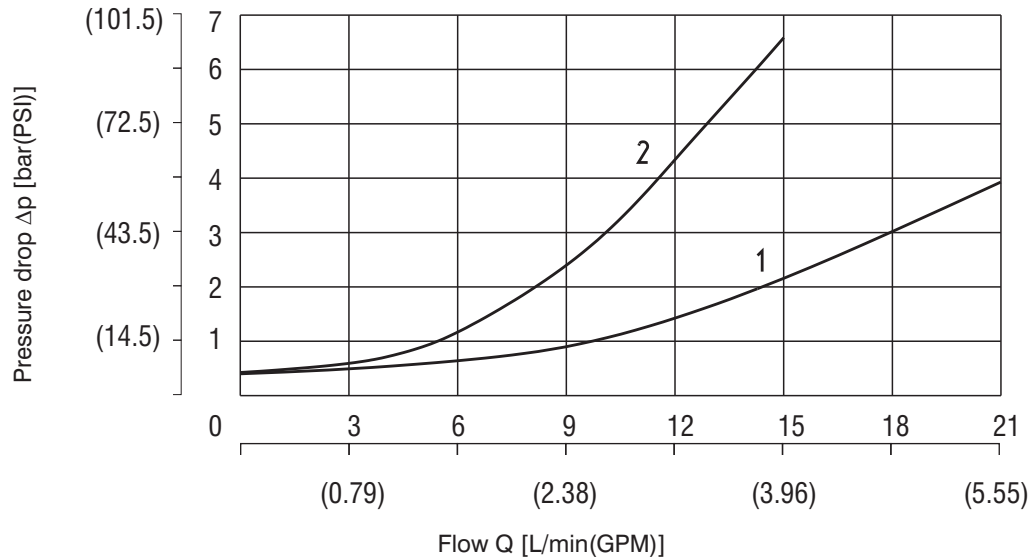

Valve Dimensions

Dimensions in millimeters (inches)

Model 01

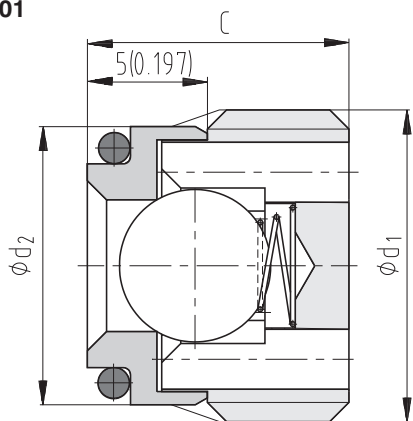

Model 02

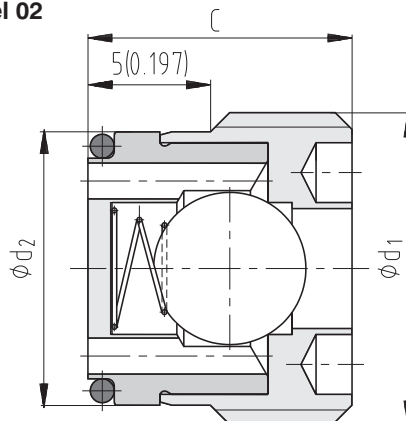

Type	ϕd_1	ϕd_2	C	O-Ring
VJO1-06/SG-1	G1/4	11.4 ^{+0.05} (0.449/0.451)	11 (0.433)	8 x 1.5
VJO1-06/SS-1	SAE 5 1/2-20			
VJO1-06/SG-2	G1/4	11.4 ^{+0.05} (0.449/0.451)	11 (0.433)	9 x 1
VJO1-06/SS-2	SAE 5 1/2-20			

Mounting Mandrel

Dimensions in millimeters (inches)

Model 01

Model 02

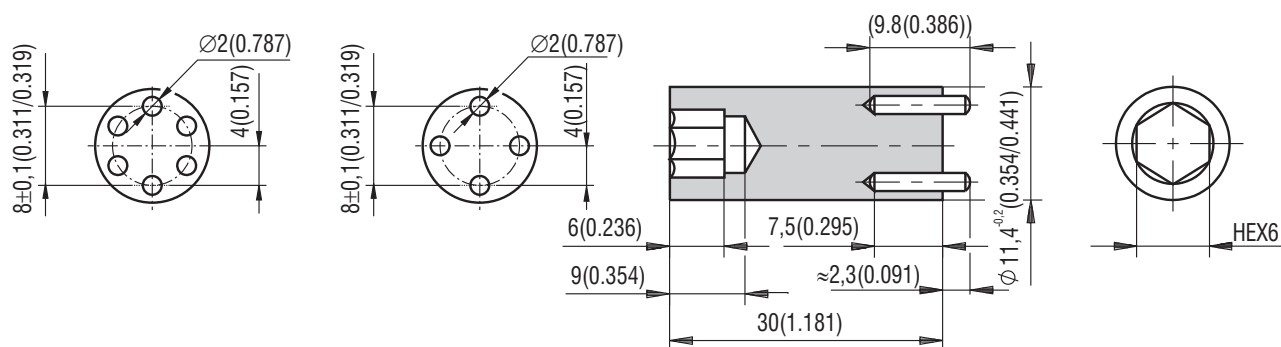

Type	Tightening torque	Ordering number
VJO1-06/Sx-1	15 Nm (11.13 ft-lbf)	15949500
VJO1-06/Sx-2	15 Nm (11.13 ft-lbf)	28395600

Cavity

Dimensions in millimeters (inches)

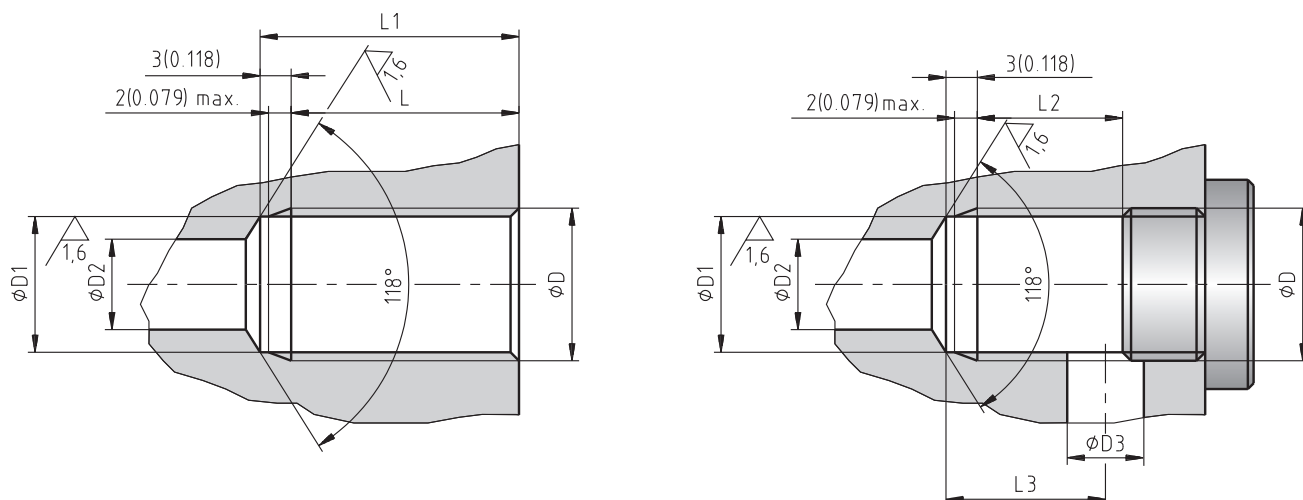

Type	ϕD	ϕD_1	ϕD_2	ϕD_3	L	L1	L2	L3
VJO1-06	G1/4; SAE 5 1/2-20	11.5 ^{+0.1} (0.453/0.457)	7 (max. 0.276)	6 (0.236)	20 (0.787)	23 (0.906)	14 (0.551)	14 (0.551)

2

Spare Parts

Dimensions in millimeters

Seal kit			
	Type	Dimension, quantity	Ordering number
Standard NBR90	VJO1-06/SG-1	O-Ring 8 x 1.5 (1 pc.)	16755400
	VJO1-06/SG-2	O-Ring 9 x 1 (1 pc.)	15949700
Viton	VJO1-06/SG-1	O-Ring 8 x 1.5 (1 pc.)	16969800
	VJO1-06/SG-2	O-Ring 9 x 1 (1 pc.)	15949800
Spare Parts kit			
	Type	Dimensions, quantity	Ordering number
Standard NBR	VJO1-06/SS-1	Seat (1 pc.) Bullet D 6.35 (1 pc.) Spring (1 pc.) O-Ring 8 x 1.5 (1 pc.) Body (1 pc.)	22688000
	VJO1-06/SS-2	Stay (1 pc.) Bullet D 6.35 (1 pc.) Spring (1 pc.) O-Ring 9 x 1 (1 pc.) Body (1 pc.)	22688100
Viton	VJO1-06/SS-1	Seat (1 pc.) Bullet D 6.35 (1 pc.) Spring (1 pc.) O-Ring 8 x 1.5 (1 pc.) Body (1 pc.)	22688200
	VJO1-06/SS-2	Stay (1 pc.) Bullet D 6.35 (1 pc.) Spring (1 pc.) O-Ring 9 x 1 (1 pc.) Body (1 pc.)	22688300

Caution!

- The packing foil is recyclable.
- The technical information regarding the product presented in this catalogue is for descriptive purposes only. It should not be construed in any case as a guaranteed representation of the product properties in the sense of the law.

ARGO-HYTOS s.r.o. CZ - 543 15 Vrchlabí
 Tel.: +420-499-403111, Fax: +420-499-403421
 E-mail: sales.cz@argo-hytos.com
 www.argo-hytos.com

- Sandwich plate design for use in vertical stacking assemblies
- Poppet design
- Leakfree closure in one or two service ports
- 8 different models
- Installation dimensions to ISO 4401 CETOP - RP 121H

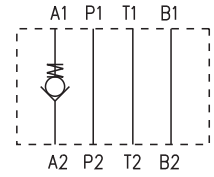

Functional Description

The check valves sandwich plate are used to allow flow in one direction and prevent flow in the other in the port in which the check element is installed. The sandwich design enables stacking with other components of the same size. The check elements are built into one or two ports, the other ports being through-holes. The seat (3)

is machined directly in the housing (1) and the poppet (2) is pushed onto the seat by the compression spring (4). The cracking pressure depends on the spring selected and the pressurised poppet surface area. The valve housing surface is phosphate coated.

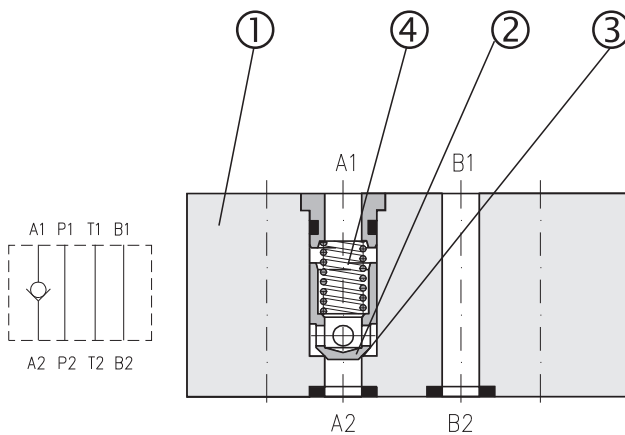

Model A

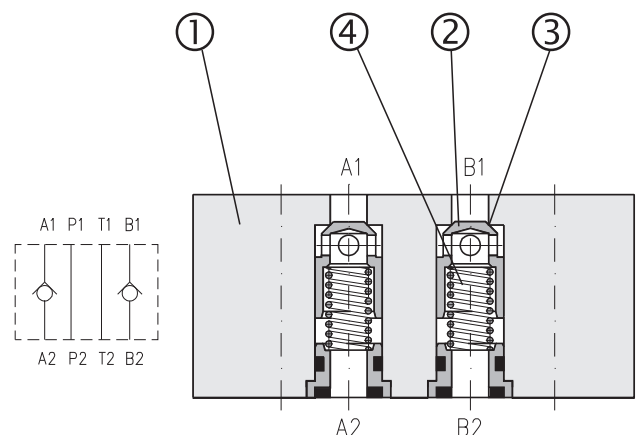

Model D

Ordering Code

2

VJO1-04/M -

Sandwich Check Valve Plate for Stacking Assemblies

Valve size **04 (D 02)**

Sandwich plate design

no designation
V

Seal
NBR
FPM (Viton)

Cracking pressure
05 0.5 bar (7 PSI)
15 1.5 bar (22 PSI)
30 3.0 bar (43 PSI)

A
B
E
F
D
P
T
H

Functional Symbols
Check valve in line * A
Check valve in line * B
Check valve in line * A
Check valve in line * B
Check valves in lines * A and B
Check valve in line * P
Check valve in line * T
Check valves in lines * P and T

* see the table Functional symbols

Functional symbols

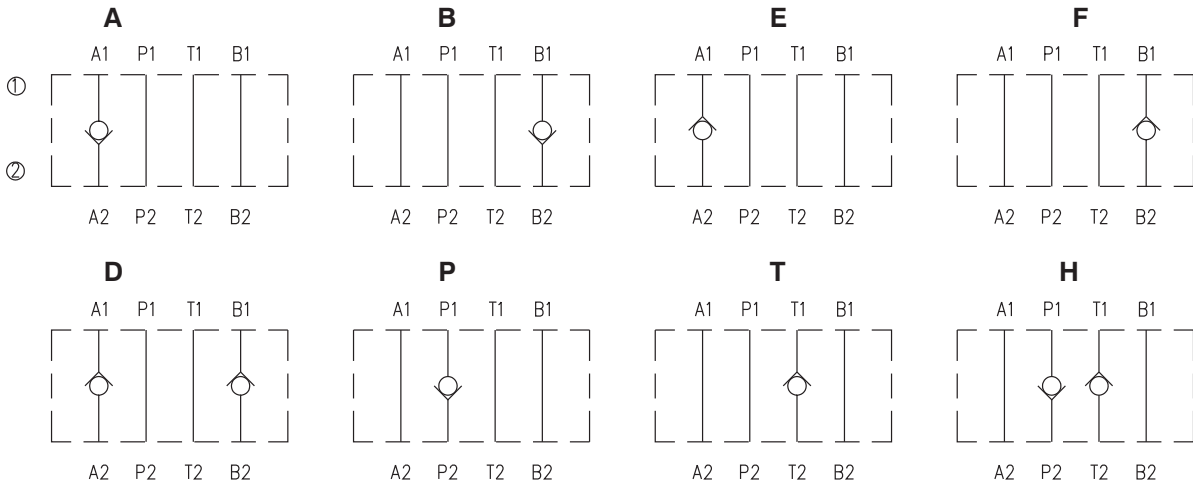

Notes: Symbol orientation on the label corresponds with the valve function.

- ① valve side
- ② subplate or manifold side

Technical Data

Valve size	mm (US)	04 (D 02)		
Maximum flow	L/min (GPM)	30 (7.94)		
Maximum operating pressure	bar (PSI)	320 (4600)		
Cracking pressure	bar (PSI)	0,5 (7)	1,5 (0.4)	3 (0.8)
Hydraulic fluid		Hydraulic oils of power classes (HL, HLP) to DIN 51524		
Fluid temperature range for standard sealing (NBR)	°C (°F)	-30 ... +100 (-22... +212)		
Fluid temperature range for Viton seals (FPM)	°C (°F)	-20 ... +120 (-4... +248)		
Viscosity range	mm ² /s (SUS)	20 ... 400 (98... 1840)		
Maximum degree of fluid contamination		Class 21/18/15 to ISO 4406		
Weight	kg (lbs)	0,40 (0.879)		
Mounting position		unrestricted		

Δp-Q Characteristics

Measured at $v = 32 \text{ mm}^2/\text{s}$ (156 SUS)

Pressure drop Δp related to flow rate.

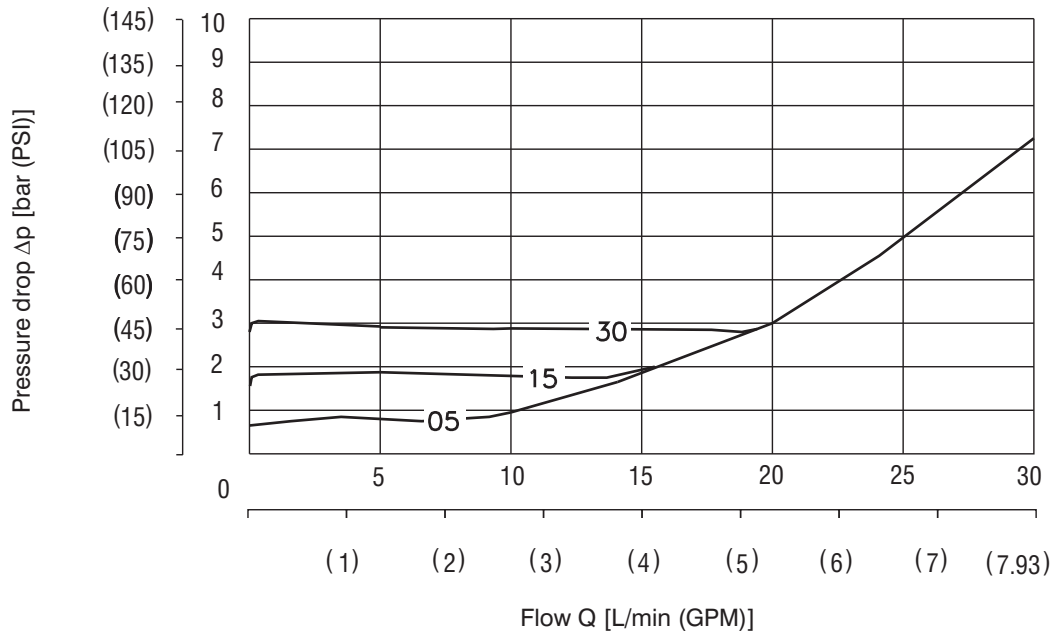

Valve Dimensions

Dimensions in millimeters (inches)

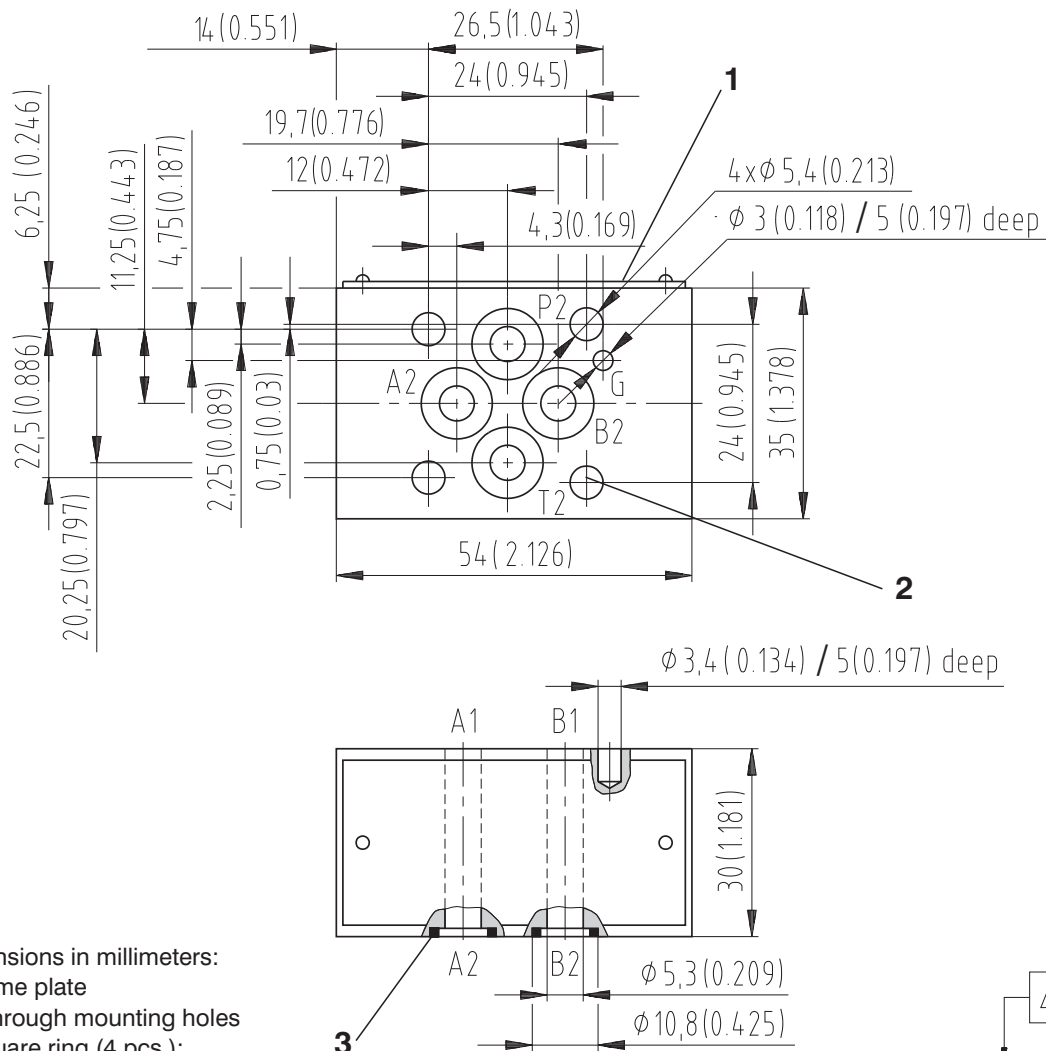

- Dimensions in millimeters:
- 1 Name plate
 - 2 4 through mounting holes
 - 3 Square ring (4 pcs.):
standard (NBR) - SR 010 6.07 x 1.68
Viton (FPM) - 6.07 x 1.78
supplied with valve

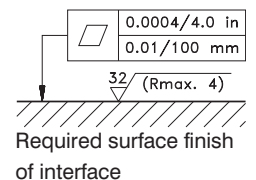

Spare Parts

Dimensions in millimeters

Seal kit

Type	Dimensions, quantity		Ordering number
	Square ring	O-ring	
Standard NBR	6,07 x 1,68 (4 pcs.)	-	15946100
Viton	-	6,7 x 1,78 (4 pcs.)	22662600

Caution!

- The packing foil is recyclable.
- The protective plate can be returned to manufacturer.
- The technical information regarding the product presented in this catalogue is for descriptive purposes only. It should not be construed in any case as a guaranteed representation of the product properties in the sense of the law.

ARGO-HYTOS s.r.o. CZ - 543 15 Vrchlaví
 Tel.: +420-499-403111, Fax: +420-499-403421
 E-mail: sales.cz@argo-hytos.com
 www.argo-hytos.com

- Sandwich plate design for use in vertical stacking assemblies
- Poppet design
- Leakfree closure in one or two service ports
- 8 different models
- Installation dimensions to ISO 4401/ DN 24 340

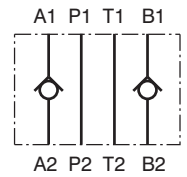

Functional Description

The check valve sandwich plates are used to allow flow in one direction and prevent flow in the other one. The sandwich design enables vertical stacking with other components of the same size. The check elements can be built into one or two ports, the other ports being through-holes.

The seat (3) is machined directly in the housing (1) and the poppet (2) is pushed onto the seat by compression spring (4). The cracking pressure depends on the spring used, on its preload and on the pressurized poppet surface area.

The valve housing surface is phosphate coated.

MODEL AB

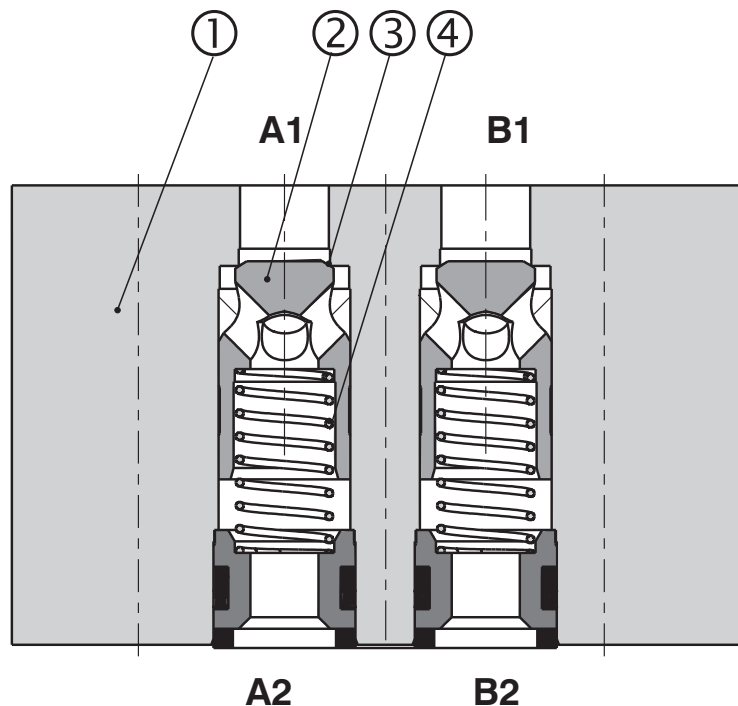

Ordering Code

2

MVJ3-06 - -

Sandwich Check Valve Plate for Stacking Assemblies

Nominal size

Functional symbols

- Check valve in line P*
- Check valve in line T*
- Check valve in line A*
- Check valve in line B*
- Check valve in line A*
- Check valve in line B*
- Check valve in line A a B*
- Check valve in line P a T*

* see the table Functional symbols

P
T
A
B
C
D
AB
PT

no designation
V

Seals
NBR
FPM (Viton)

no designation
A

Surface finishing
Phosphate
PO-A

005
015
030
050

Cracking pressure
0,5 bar (7.25 PSI)
1,5 bar (21.75 PSI)
3,0 bar (43.51 PSI)
5,0 bar (72.51 PSI)

Functional symbols

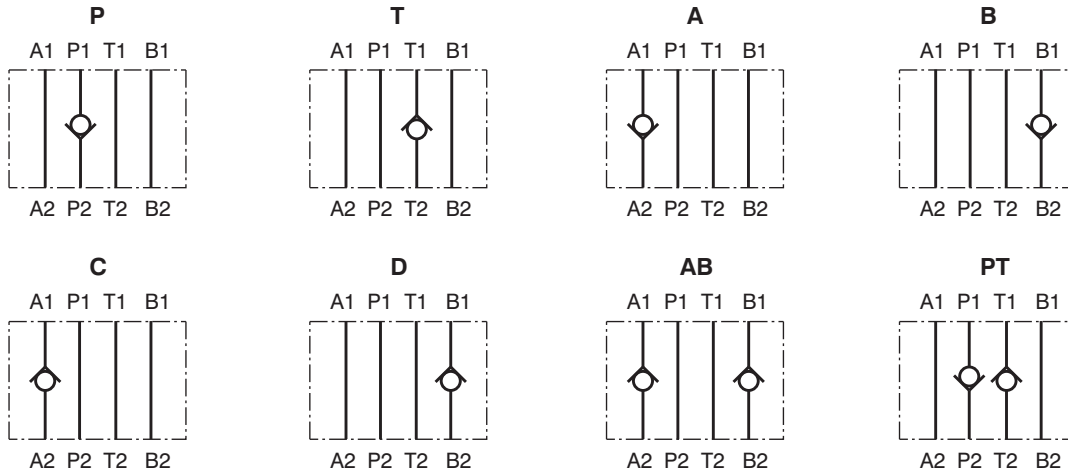

Notes: The orientation of the symbol on the name plate corresponds with the valve function.

- ① valve side
- ② subplate or manifold side

Technical Data

Valve size	mm (US)	06 (D 03)
Maximal flow	L/min (GPM)	50 (13.2)
Maximum operating pressure	bar (PSI)	350 (5076)
Cracking pressure	bar (PSI)	0,5 (7.25) 1,5 (21.75) 3 (43.51) 5 (72.51)
Hydraulic fluid		Hydraulic oils of power classes (HL, HLP) to DIN 51524
Fluid temperature range for standard sealing (NBR)	°C (°F)	-30 ... +80 (-22 ... +176)
Fluid temperature range for Viton seals (FPM)	°C (°F)	-20 ... +80 (-4 ... +176)
Viscosity range	mm ² /s (SUS)	20 ... 400 (98 ... 1840)
Maximum degree of fluid contamination		Class 21/18/15 to ISO 4406
Weight	kg (lbs)	0.8 (1.8)
Mounting position		unrestricted

Δp-Q Characteristics

Measured at $v = 32 \text{ mm}^2/\text{s}$ (156 SUS)

Pressure drop Δp related to flow rate.

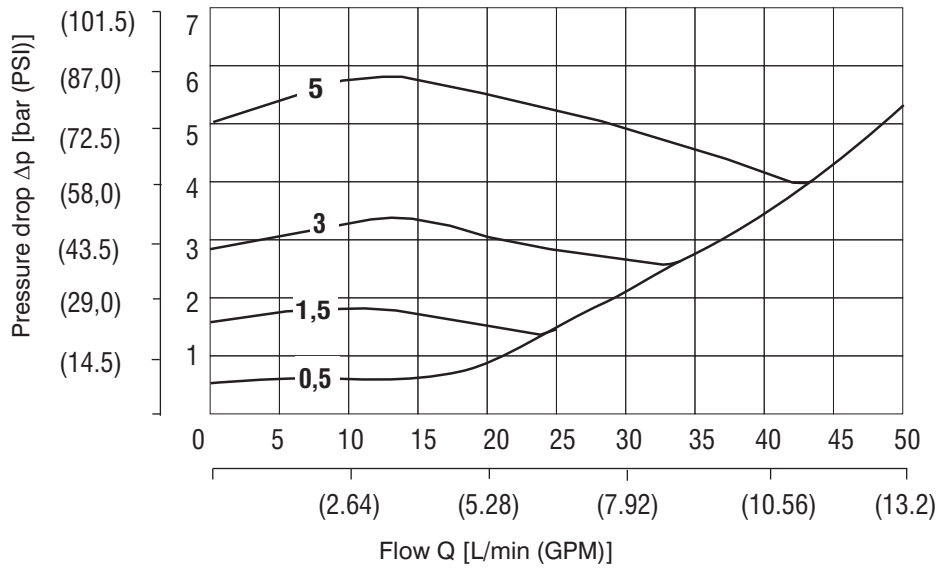

Valve Dimensions

Dimensions in millimeters (inches)

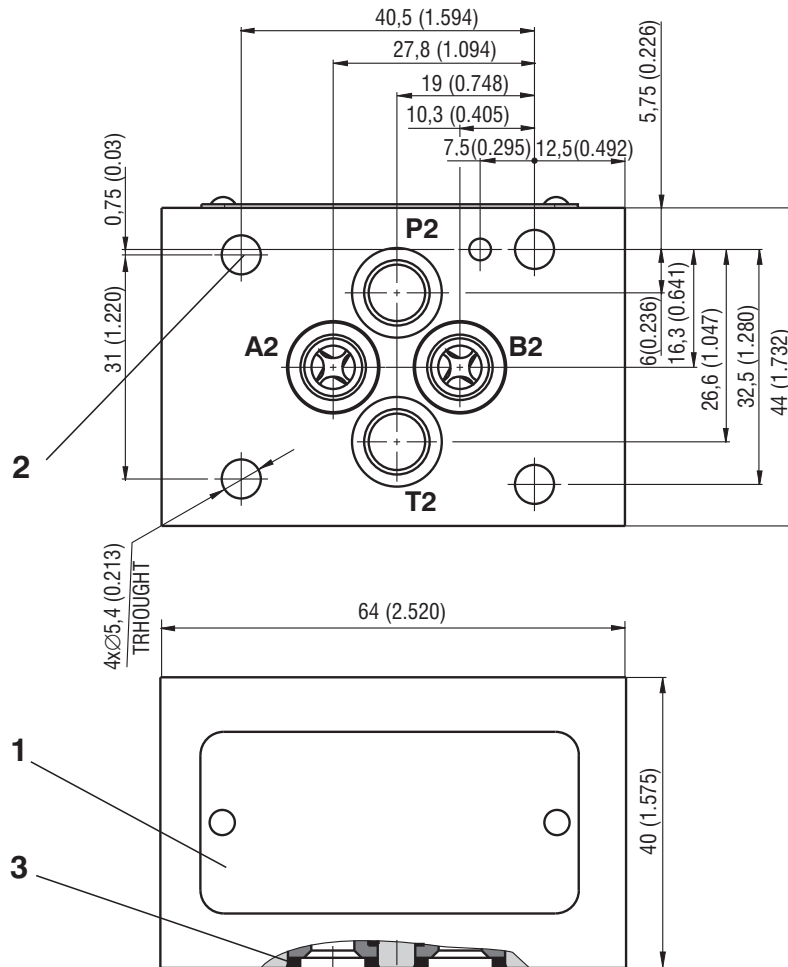

Dimensions in millimeters (inches):

- 1 Name plate
- 2 4 mounting through-holes
- 3 Seal kit, supplied with valve

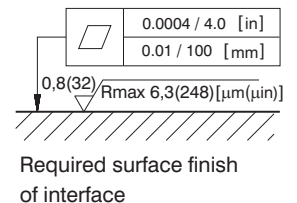

Spare Parts

Dimensions in millimeters (inches)

Seal kit

Type	Dimensions, quantity		Order number
	O-Ring	Square Ring	
Standard NBR70	-	9,25 x 1,68 (4 pcs.)	28551800
Viton	9,25 x 1,78 (4 pcs.)	-	28551900

Caution!

- The packing foil is recyclable.
- The protective plate can be returned to manufacturer.
- Mounting bolts M5 must be ordered separately. Tightening torque of the bolts is 8.9 Nm.
- The technical information regarding the product presented in this catalogue is for descriptive purposes only. It should not be construed in any case as a guaranteed representation of the product properties in the sense of the law.

ARGO-HYTOS s.r.o. CZ - 543 15 Vrchlábí
 Tel.: +420-499-403 111,
 E-mail: info.cz@argo-hytos.com
 www.argo-hytos.com

- Sandwich plate design for use in vertical stacking assemblies
- Poppet design
- Leakfree closure in one or two service ports
- 8 different models
- Installation dimensions to ISO 4401 / DN 24 340

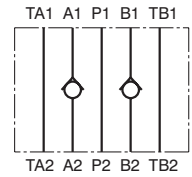

Functional Description

The check valve sandwich plates are used to allow flow in one direction and prevent flow in the other one. The sandwich design enables vertical stacking with other components of the same size. The check elements can be built into one or two ports, the other ports being through-holes.

The seat (3) is machined directly in the housing (1) and the poppet (2) is pushed onto the seat by compression spring (4). The cracking pressure depends on the spring used, on its preload and on the pressurized poppet surface area.

The valve housing surface is phosphate coated.

MODEL AB

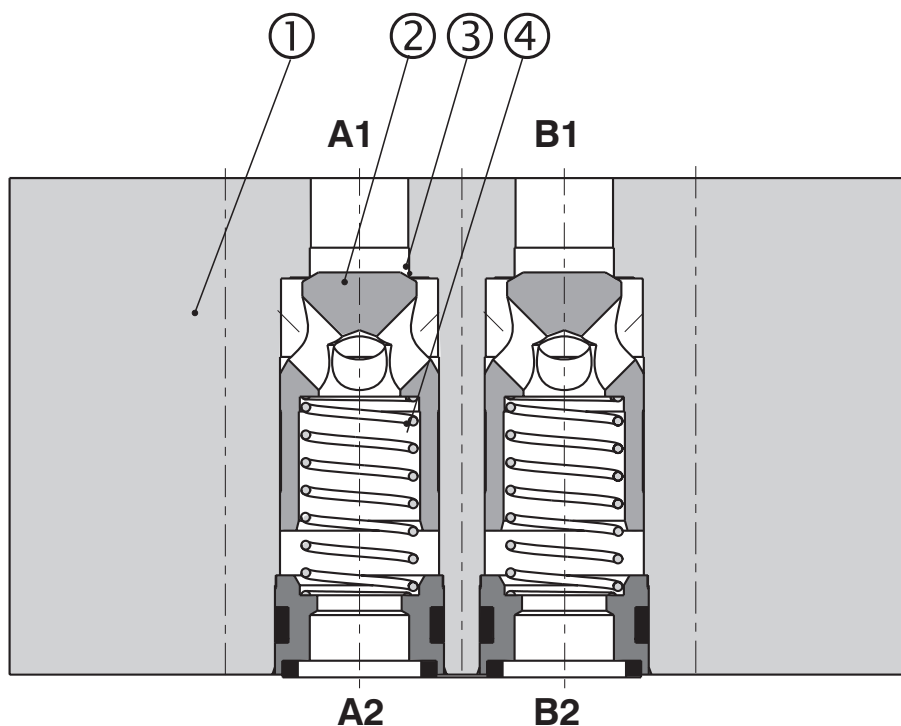

Ordering Code

2

MVJ3-10 - -

Sandwich Check Valve Plate for Stacking Assemblies

Nominal size

Functional symbols

- Check valve in line P*
- Check valve in line T*
- Check valve in line A*
- Check valve in line B*
- Check valve in line A*
- Check valve in line B*
- Check valve in line A a B*
- Check valve in line P a T*
- * see the table Functional symbols

P
T
A
B
C
D
AB
PT

no designation
V

Seals
NBR
FPM (Viton)

no designation
A

Surface finishing
Phosphate
PO-A

005
030
050

Cracking pressure
0,5 bar (7.25 PSI)
3,0 bar (43.51 PSI)
5,0 bar (72.51 PSI)

Functional symbols

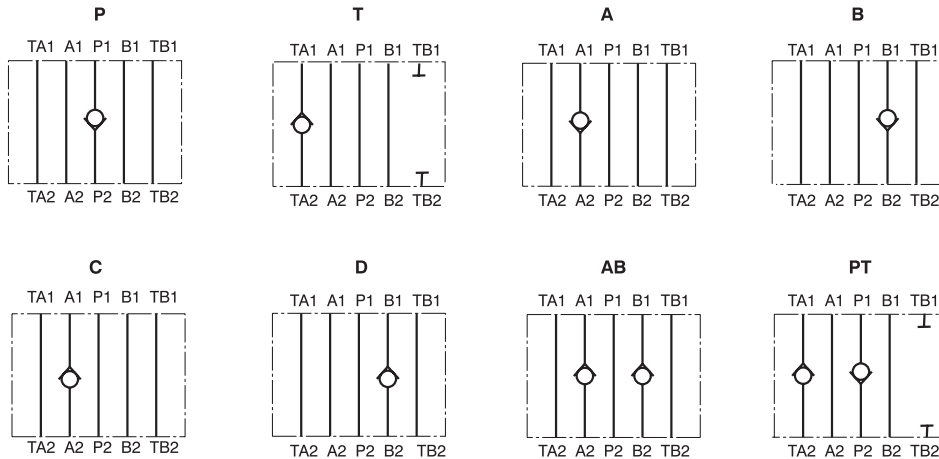

Notes: The orientation of the symbol on the name plate corresponds with the valve function.
Port TB is closed with models T and PT.

- ① valve side
- ② subplate or manifold side

Technical Data

Valve size	mm (US)	10 (D 05)
Maximal flow	L/min (GPM)	100 (26.4)
Maximum operating pressure	bar (PSI)	350 (5076)
Cracking pressure	bar (PSI)	0,5 (7.25) 3 (43.51) 5 (72.51)
Hydraulic fluid		Hydraulic oils of power classes (HL, HLP) to DIN 51524
Fluid temperature range for standard sealing (NBR)	°C (°F)	-30 ... +80 (-22 ... +176)
Fluid temperature range for Viton seals (FPM)	°C (°F)	-20 ... +80 (-4 ... +176)
Viscosity range	mm ² /s (SUS)	20 ... 400 (98 ... 1840)
Maximum degree of fluid contamination		Class 21/18/15 to ISO 4406
Weight	kg (lbs)	2.25 (4.96)
Mounting position		unrestricted

Δp-Q Characteristics

Measured at $v = 32 \text{ mm}^2/\text{s}$ (156 SUS)

Pressure drop Δp related to flow rate.

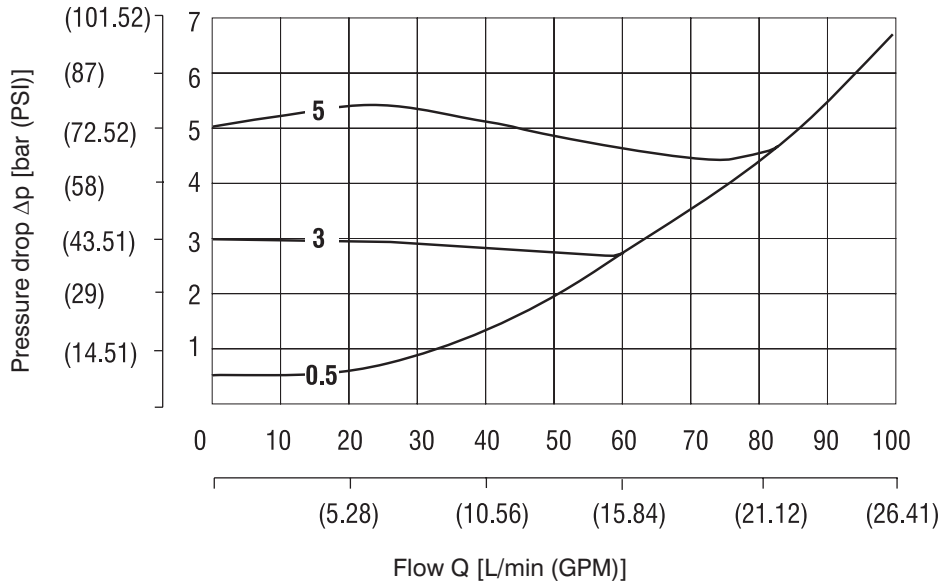

Valve Dimensions

Dimensions in millimeters (inches)

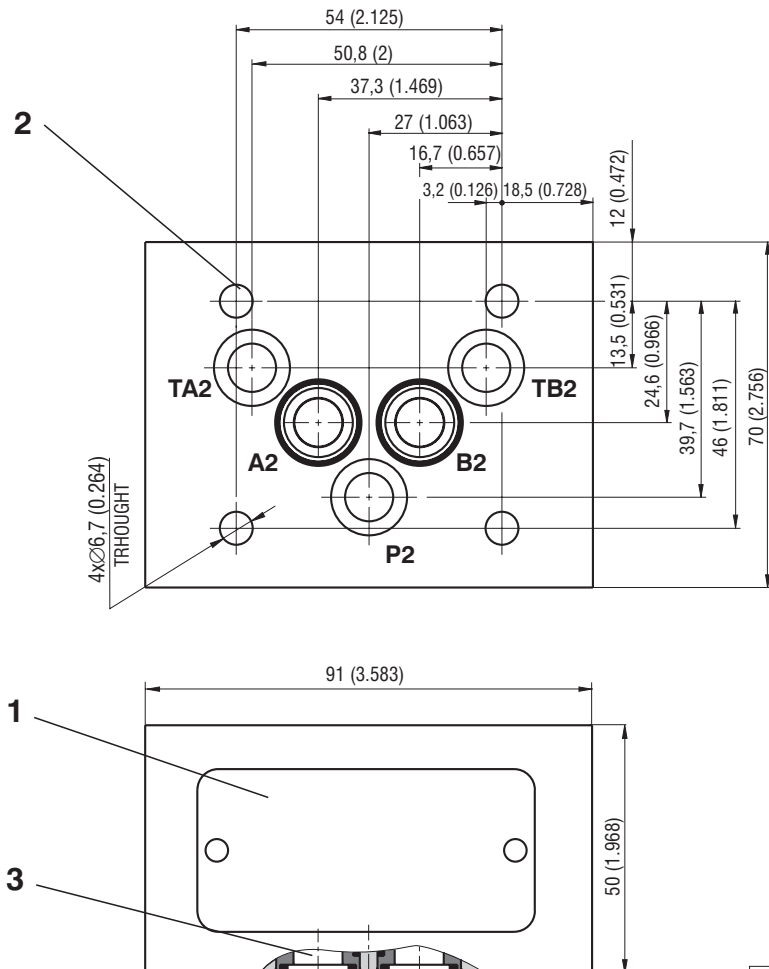

- Dimensions in millimeters:
- 1 Name plate
 - 2 4 mounting through-holes
 - 3 Square ring 12.42x1.68 (5 pcs.) supplied with valve

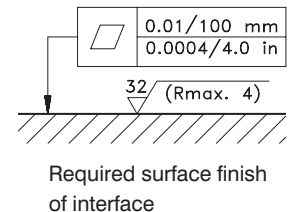

Spare Parts

Dimensions in millimeters

Seal kit

Type	Dimensions, quantity		Orderind number
	O-ring	Square ring	
Standard NBR70	-	12.42x1.68 (5 pcs.)	15991600
Viton	12.42x1.68 (5 pcs.)	-	22943800

Caution!

- The packing foil is recyclable.
- The protective plate can be returned to manufacturer.
- Mounting bolts M6 must be ordered separately. Tightening torque of the bolts is 15 Nm.
- The technical information regarding the product presented in this catalogue is for descriptive purposes only. It should not be construed in any case as a guaranteed representation of the product properties in the sense of the law.

ARGO-HYTOS s.r.o. CZ - 543 15 Vrchlábí
 Tel.: +420-499-403111, Fax: +420-499-403421
 E-mail: sales.cz@argo-hytos.com
 www.argo-hytos.com

- Sandwich plate design for use in vertical stacking assemblies
- 3 models:
 - leakfree closure of both sides with check valves in lines A and B
 - leakfree closure with check valve in line A
 - leakfree closure in line B
- Installation dimensions according to ISO 4401 / DIN 24 340

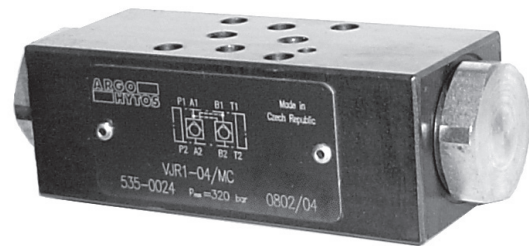
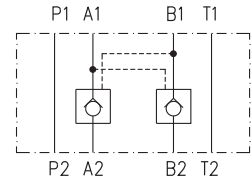

Functional Description

A pilot operated check valve is used to provide leakfree closure of a hydraulic circuit under pressure. It protects the load against dropping should a line break occur and ensures a stable position of a hydraulic actuator under pressure, even during long idle periods.

The valve basically consists of housing (1), one or two check valves (2), (3) and pilot piston (4).

When fluid flows from A1 (B1) to A2 (B2) it opens the check valve (2), (3) and at the same time shifts the pilot piston (4) to the right (left), thus opening the way B2→B1 (A2→A1). When the pressure drops (e.g. after shifting

the directional valve into its middle position), the springs push the balls onto the seats and the circuit between the check valve and the actuator is closed under pressure.

To ensure that the ball valves seat properly and that they perfectly close ports A2 and B2, a directional valve with functional symbol Y is to be used, which connects in its neutral position both sides of the pilot piston (4) with tank.

The valve housing surface is phosphate coated, the surfaces of the other parts are zinc coated.

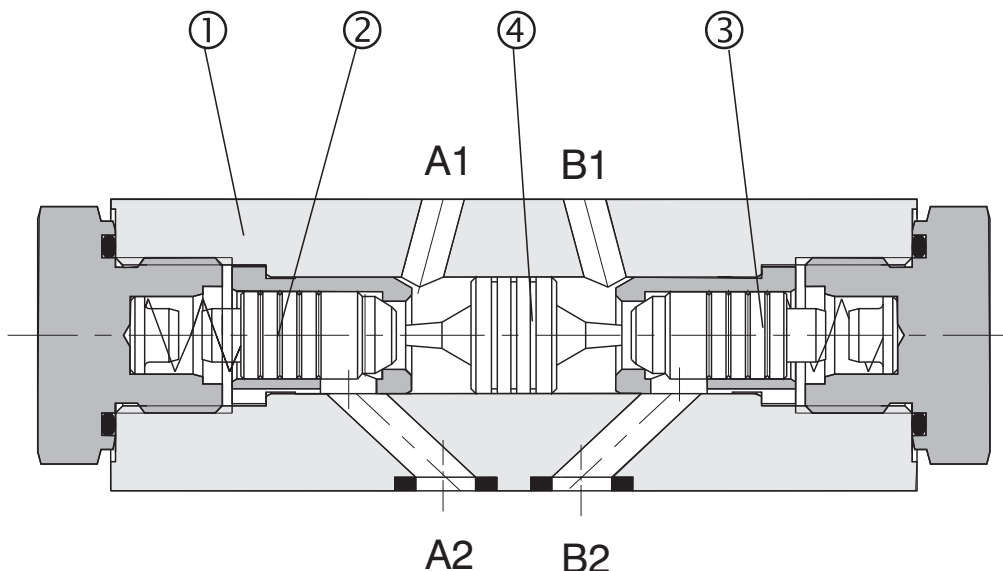

Ordering Code

**Pilot Operated Check Valve
Sandwich Plate**

Valve size

04 (D 02)

Modular design

VJR1-04/M

**no designation
V**

**Seals
(NBR)
FPM (Viton)**

**A
B
C**

Functional Symbols
check valve in line A*
check valve in line B*
check valves in lines A and B*
* see the table Functional symbols

Functional Symbols

Arrangement of the check valves in the valve body

VJR1-04/MA

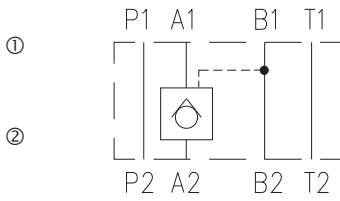

VJR1-04/MB

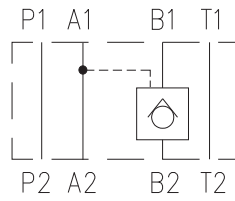

VJR1-04/MC

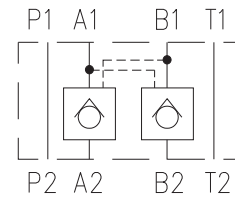

- ① valve side
- ② subplate side

Typical circuit with pilot operated check valve

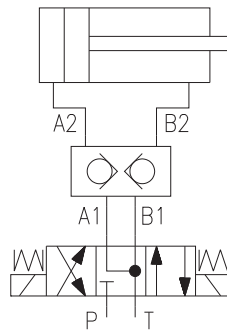

Technical Data

Valve size	mm (US)	04 (D 02)
Maximum flow	L/min (GPM)	20 (5.28)
Maximum operating pressure	bar (PSI)	320 (4600)
Cracking pressure	bar (PSI)	1(14.5)
Hydraulic fluid	Hydraulic oils of power classes (HL, HLP) to DIN 51524	
Fluid temperature range (NBR)	°C (°F)	-30...+100 (-22 ... +212)
Fluid temperature range (Viton)	°C (°F)	-20...+120 (-4 ... +248)
Viscosity range	mm ² /s (SUS)	20...400 (98 ... 1840)
Maximum degree of fluid contamination	Class 21/18/15 to ISO 4406	
Area ratio (pilot piston / seat)	3 : 1	
Mounting position	unrestricted	
Weight	kg (lbs)	0,7(1.54)

Δp-Q Characteristics

Measured at $v = 32 \text{ mm}^2/\text{s}$ (156SUS)

Pressure drop Δp related to flow rate.

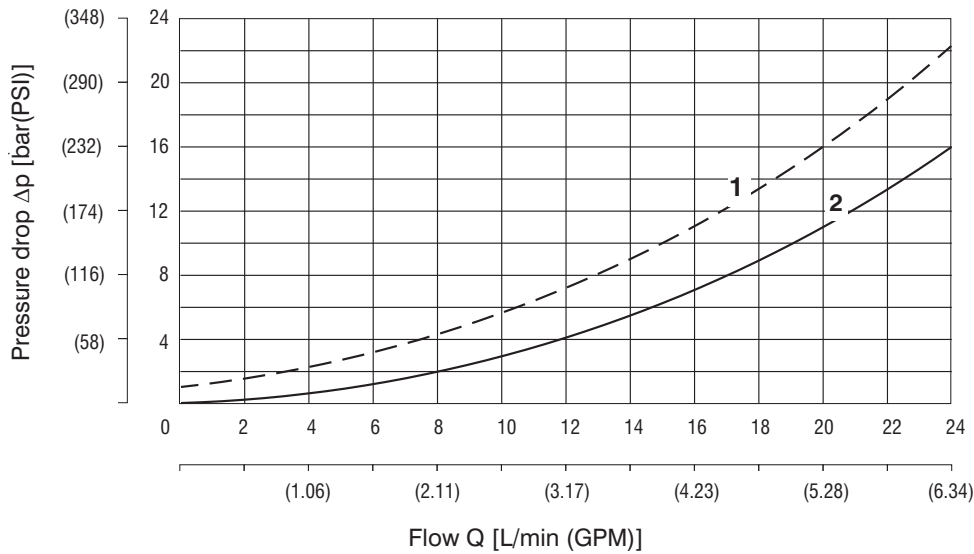

	Flow in direction
1	A1 → A2 (B1 → B2)
2	A2 → A1 (B2 → B1)

Valve Dimensions

Dimensions in millimeters and inches

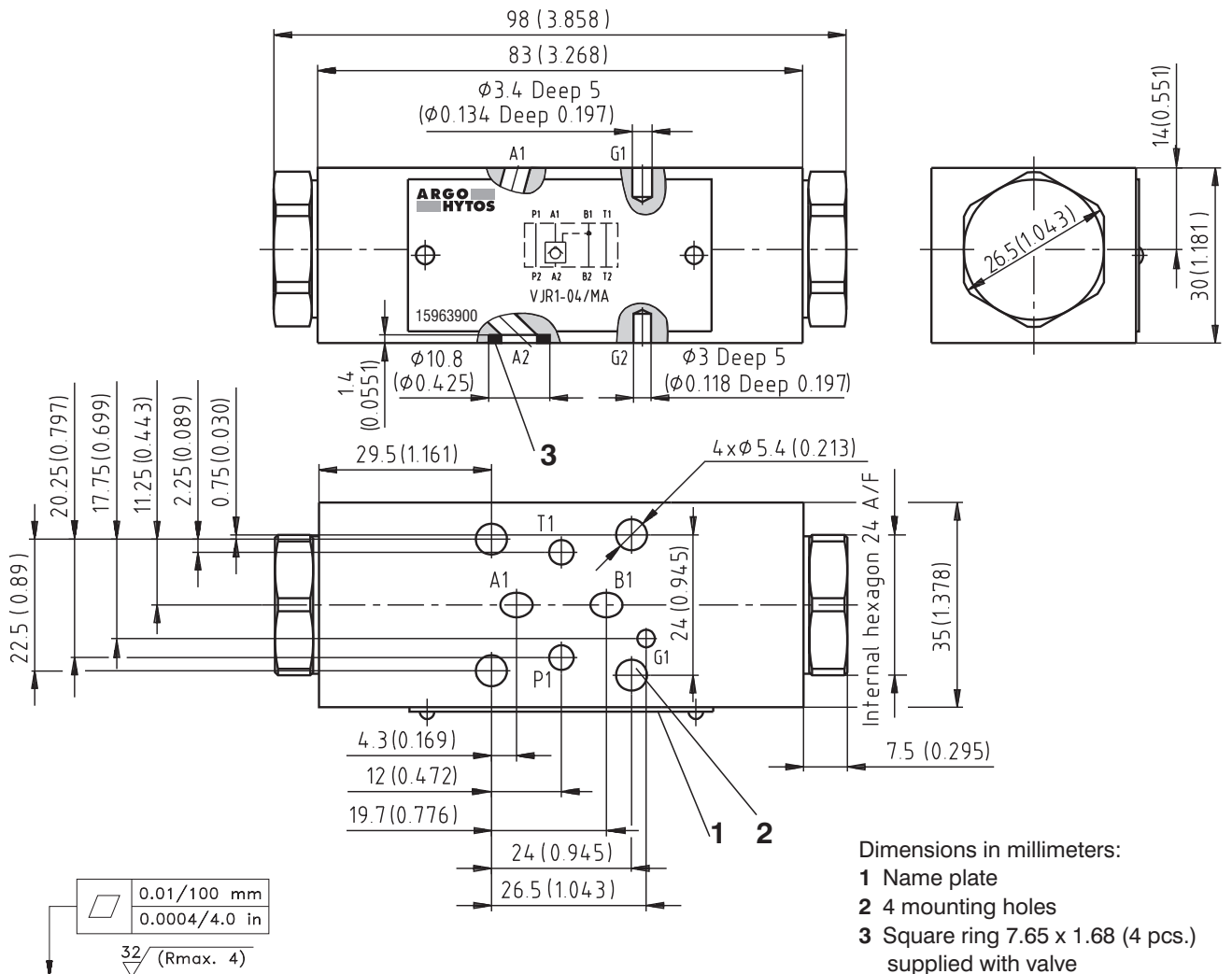

Dimensions in millimeters:

- 1 Name plate
- 2 4 mounting holes
- 3 Square ring 7.65 x 1.68 (4 pcs.) supplied with valve

Required surface finish of interface

Spare Parts

Dimensions in millimeters

Seal kit

Type	Dimensions, quantity		Ordering number
	O-ring	Square ring	
Standard NBR70	-	7,65 x 1,68 (4 pcs.)	20718400
Viton	7,65 x 1,68 (4 pcs.)	-	28618000

Caution!

- The plastic packaging is recyclable.
- Mounting studs must be ordered separately. For stud kits see data sheet HU 0020.
- Certified documentation is available per request.

ARGO-HYTOS s.r.o. CZ - 543 15 Vrchlaví
 Tel.: +420-499-403111, Fax: +420-499-403421
 E-mail: sales.cz@argo-hytos.com
 www.argo-hytos.com

- Sandwich plate design for use in vertical stacking assemblies
- Three models:
 - leakfree closure in lines A and B
 - leakfree closure in line A
 - leakfree closure in line B
- Installation dimensions to ISO 4401 / DIN 24 340

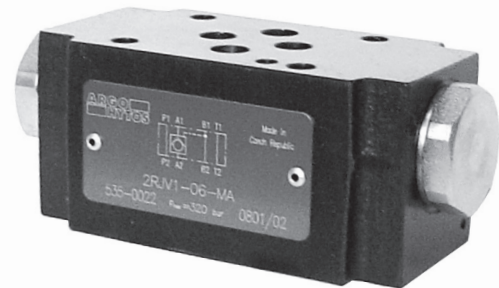
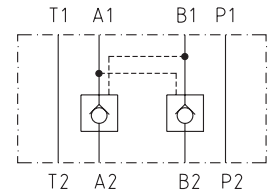

Functional Description

Model 2RJV1-06 are pilot operated check valves in a sandwich plate design used to give leakfree closure of one or two actuator ports under pressure, even during long idle periods.

The valve consists of the cast iron housing (1), one or two check valves (2), (3) and the pilot piston (4).

When fluid flows from A1 (B1) to A2 (B2) it opens the check valve (2), (3) and at the same time shifts the pilot piston (4) to the right (left), thus opening the way B2 → B1 (A2 → A1). When the pressure drops (i. e. after shifting

the directional valve into its middle position), the springs push the poppets onto the seats and the circuit between the check valve and the cylinder is closed.

To ensure that the poppet valves seat properly, the actuator ports A2 and B2 of the directional valve should be connected to tank T in neutral position (functional symbol Y).

The valve body is phosphate coated, the surfaces of the other parts are zinc coated.

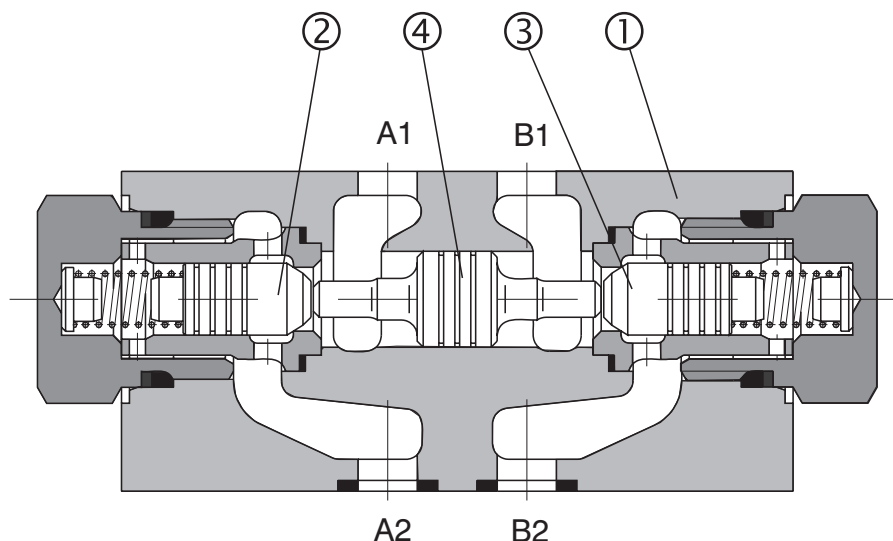

Ordering Code

2RJV1-06-M

**Pilot Operated Check Valve
Sandwich Plate**

no designation
V

Seals
NBR
Viton

Nominal size **06 (D 03)**

Functional Symbols

Check valve in line A*

Check valve in line B*

Check valves in lines A and B*

* see the table Functional symbols

A
B
C

Modular design

Functional Symbols

Arrangement of the check valves in the valve body

2RJV1-06-MA

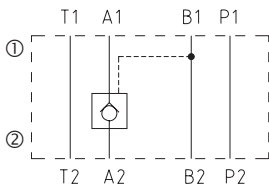

2RJV1-06-MB

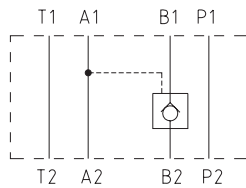

2RJV1-06-MC

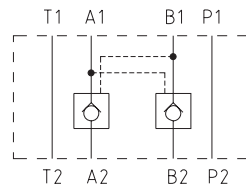

- ① valve side
- ② subplate side

Typical circuit with pilot operated check valve

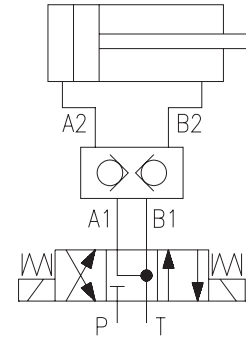

Technical Data

Valve size	mm (US)	06 (D 03)
Maximum flow	L/min (GPM)	60 (15.9)
Max. operating pressure	bar (PSI)	320 (4600)
Cracking pressure	bar (PSI)	see the Performance Curves
Hydraulic fluid		Hydraulic oils of power classes (HL, HLP) to DIN 51524
Fluid temperature range (NBR)	°C (°F)	-30 ... +100 (-22... +212)
Fluid temperature range (Viton)	°C (°F)	-20 ... +120 (-4... +248)
Viscosity range	mm ² /s (SUS)	20 ... 400 (98... 1840)
Maximum degree of fluid contamination		Class 21/18/15 to ISO 4406
Area ratio (pilot piston/poppet)		3 : 1
Mounting position		unrestricted
Weight	kg (lbs)	0,8 (1.8)

Δp-Q Characteristics

Measured at $v = 32 \text{ mm}^2/\text{s}$ (156 SUS)

Pressure drop Δp related to flow rate.

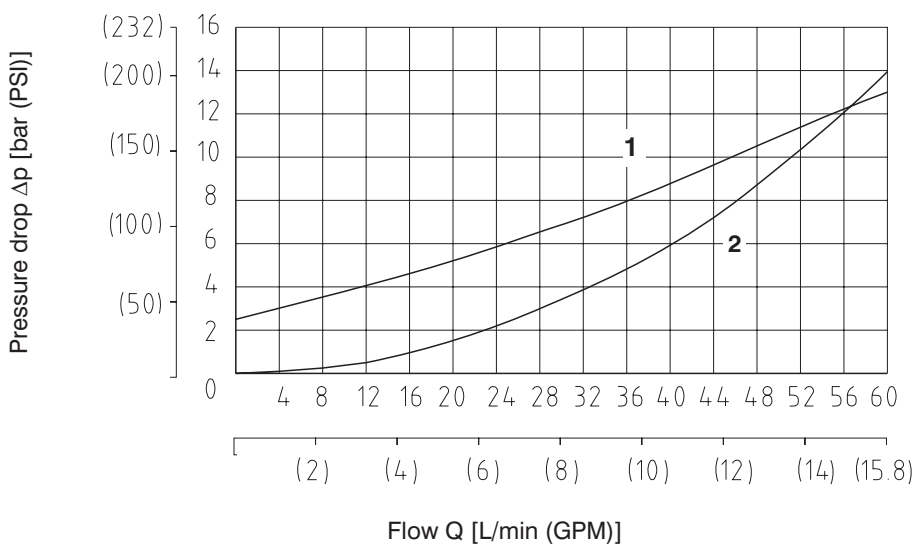

Flow in direction	
1	A1 → A2 (B1 → B2)
2	A2 → A1 (B2 → B1)

Valve Dimensions

Dimensions in millimeters (inches)

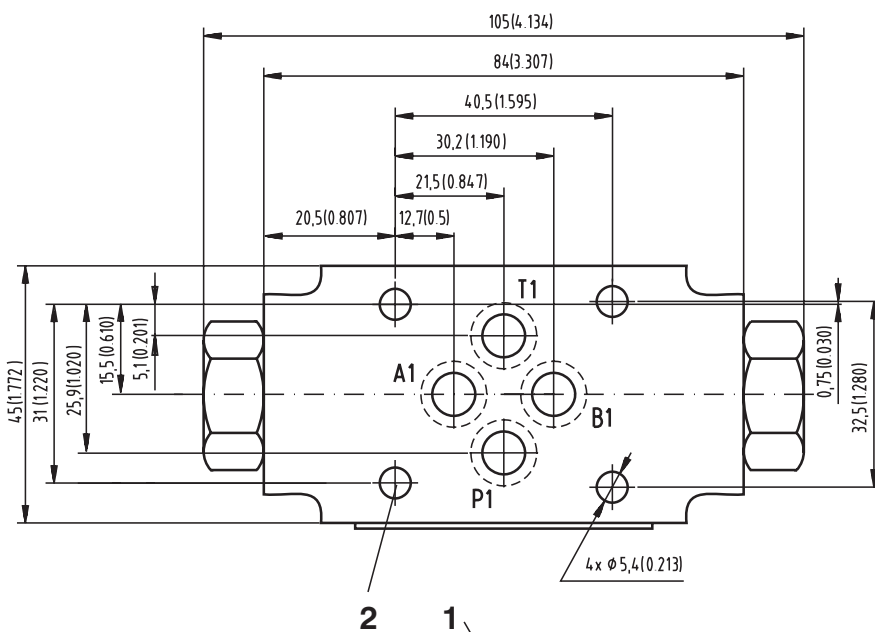

- Dimensions in millimeters:
- 1 Name plate
 - 2 4 mounting holes
 - 3 Square ring
9,25 x 1,68 NBR70 (4 pcs.)
supplied with valve

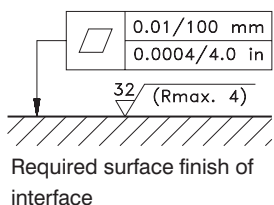
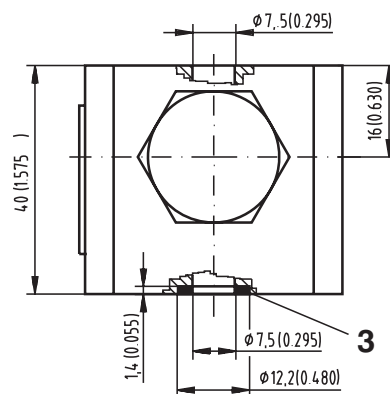
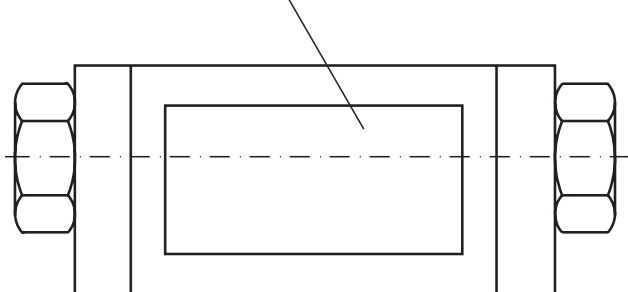

Spare Parts

Dimensions in millimeters

Seal kit

Type	Dimensions, quantity		Ordering number
	Square ring	O-ring	
Standard NBR 70	9,25 x 1,68 (4 pcs.)	-	28551800
Viton	-	9,25 x 1,78 (4 pcs.)	28551900

Caution!

- The plastic packaging is recyclable.
- Studs bolt must be ordered separately. For stud kits see data sheet HU 0030.
- Certified documentation is available per request.

ARGO-HYTOS s.r.o. CZ - 543 15 Vrchlabí
 Tel.: +420-499-403111, Fax: +420-499-403421
 E-mail: sales.cz@argo-hytos.com
 www.argo-hytos.com

- Pilot operated check valve sandwich plate for use in stacking assemblies
- 3 models
 - double valve with check valves in lines A and B
 - single valve with check valve in line A
 - single valve with check valve in line B
- Installation dimensions to ISO 4401, CETOP - RP 121H and NFPA T3.5.1 - D 02

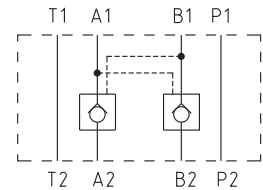

Functional Description

A pilot operated check valve closes tightly the hydraulic circuit between the valve and the actuator. The valve consists of the steel housing (1), one or two check valves (2), (3) and the pilot piston (4). The main poppets of the check valves are provided with pilot poppets (5) which enable opening the check valve under pressure. When fluid flows from A1 to A2 it opens the check valve (2) and at the same time shifts the pilot piston (4) which opens by means of the pilot poppet (5) the check valve (3). When the pressure in channels A1 and B1 drops, the

springs push the poppets onto the seats and the circuit between the check valve and the actuator is closed under pressure.

To ensure that the check valves close tightly, a directional valve with functional symbol Y is to be used, which connects in its middle position the ports A1 and B1 with tank T (see the typical circuit diagram).

The valve housing (1) is phosphate coated, the surfaces of the other parts are zinc coated.

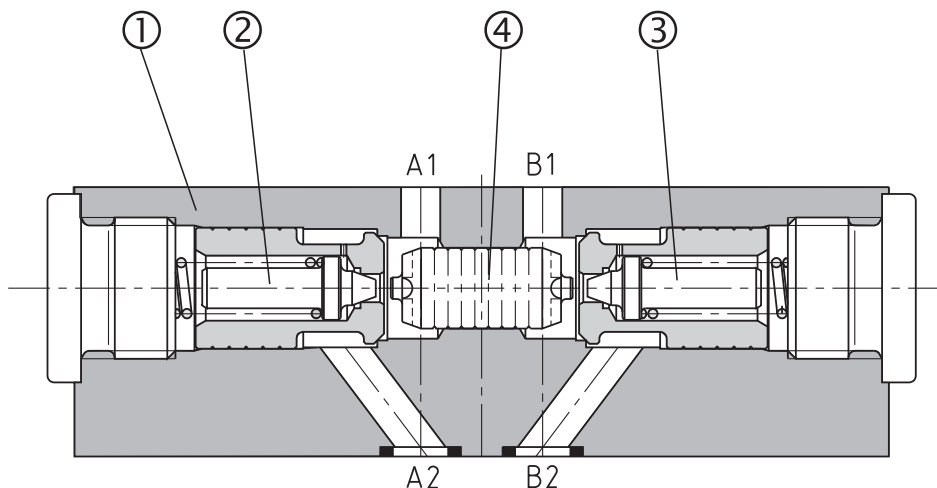

Ordering Code

VJR2-06/M

**Pilot Operated Check Valve
Sandwich Plate**

no designation
V

Seals
NBR
Viton

Valve size **06 (D 03)**

A
B
C

Functional Symbols

check valve in line A*
check valve in line B*

check valves in lines A and B*

* see the table Functional symbols

Modular design

Functional Symbols

Arrangement of the check valves in the valve body

VJR2-06/MA

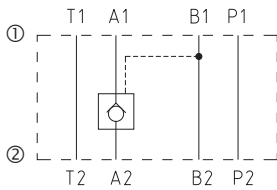

VJR2-06/MB

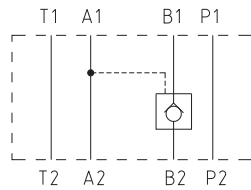

VJR2-06/MC

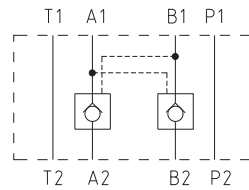

- ① valve side
- ② subplate side

Typical circuit with pilot operated check valve

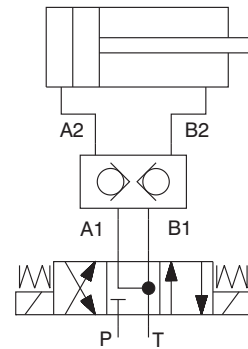

Technical Data

Valve size	mm (US)	06 (D 03)
Maximum flow	L/min (GPM)	45 (11.8)
Maximum operating pressure	bar (PSI)	320 (4600)
Cracking pressure	bar (PSI)	2(29)
Hydraulic fluid	Hydraulic oils of power classes (HL, HLP) to DIN 51524	
Fluid temperature range (NBR)	°C (°F)	-30 ... +100 (-22...+212)
Fluid temperature range (Viton)	°C (°F)	-20 ... +120(-4...+248)
Viscosity range	mm ² /s (SUS)	20 ... 400 (98...1840)
Maximum degree of fluid contamination	Class 21/18/15 to ISO 4406	
Area ration (pilot piston / seat)	8,16 : 1	
Mounting position	unrestricted	
Weight	kg (lbs)	1,6

Δp-Q Characteristics

Measured at $v = 32 \text{ mm}^2/\text{s}$ (156 SUS)

Pressure drop Δp related to flow rate.

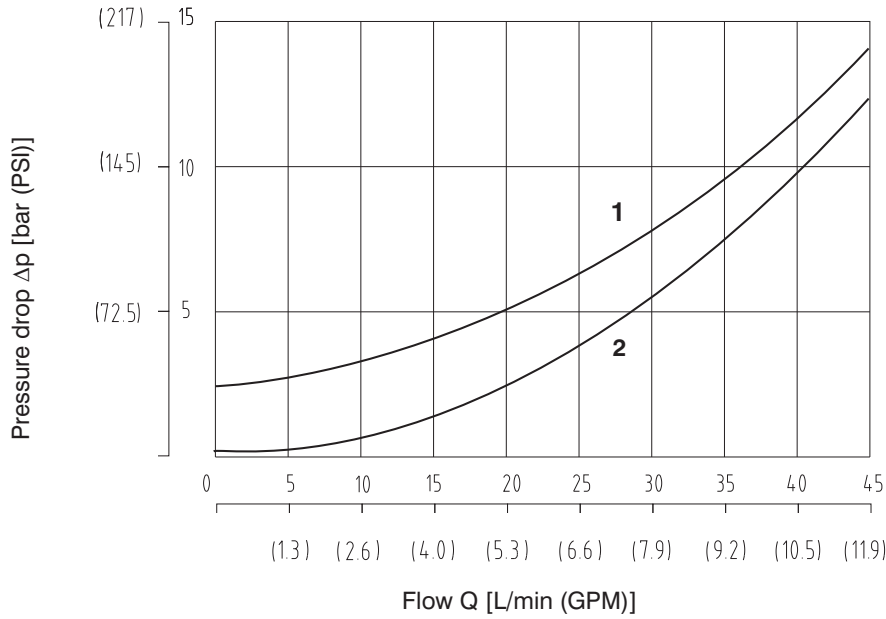

	Flow in direction
1	A1 → A2 (B1 → B2)
2	A2 → A1 (B2 → B1)

Valve Dimensions

Dimensions in millimeters and inches

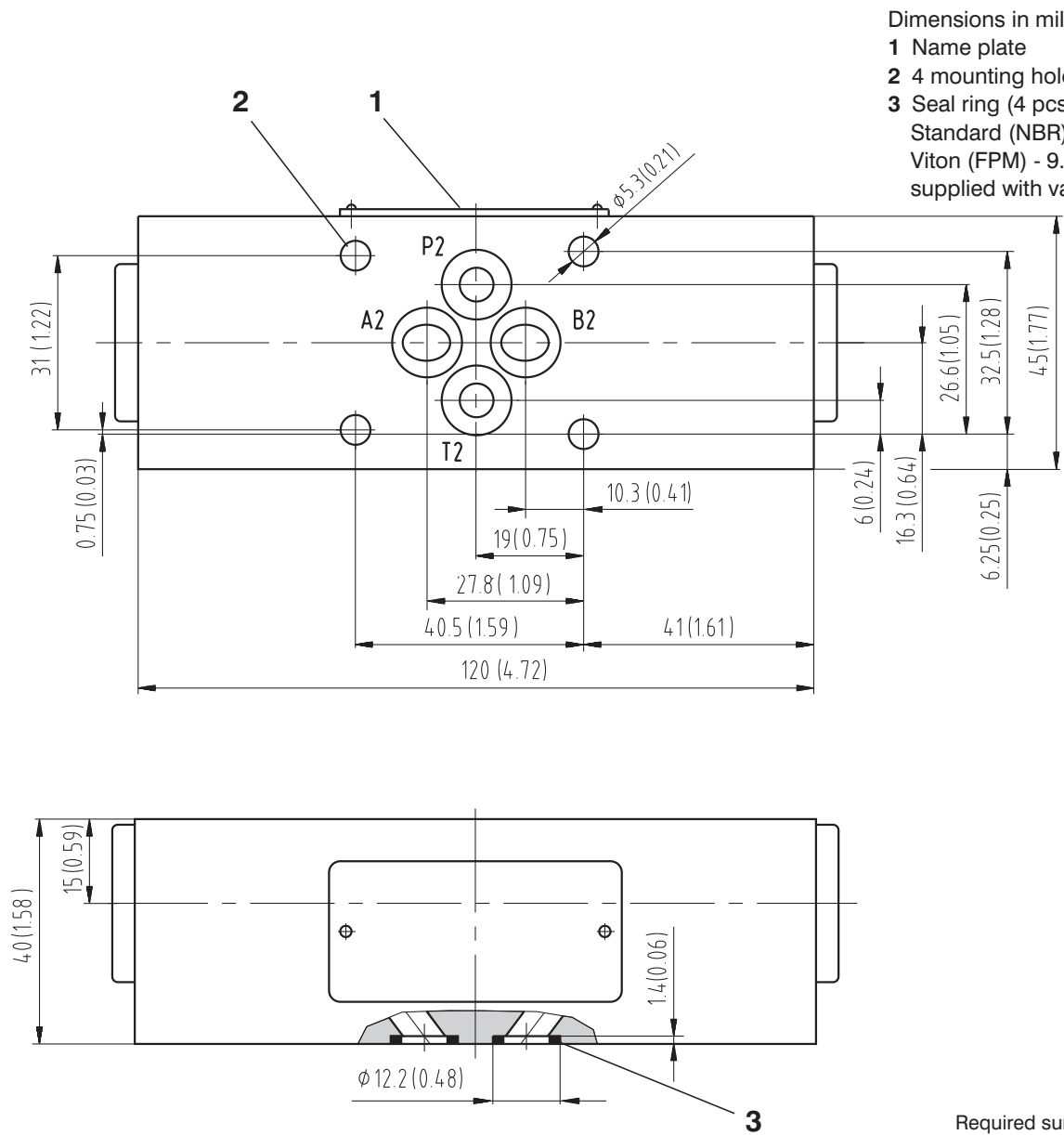

Required surface finish of interface

Spare Parts

Dimensions in millimeters

Seal kit

Type	Dimensions, quantity		Order number
	Square ring	O-ring	
Standard NBR 70	9.25 x 1.68 (4 pcs.)	-	22795100
Viton	-	9.25 x 1.78 (4 pcs.)	22795200

Caution!

- The packing foil is recyclable.
- Tightening torque of the screws is 6.6 ft-lbs (8.9 Nm).
- Certified documentation is available per request.

ARGO-HYTOS s.r.o. CZ - 543 15 Vrchlábí
 Tel.: +420-499-403111, Fax: +420-499-403421
 E-mail: sales.cz@argo-hytos.com
 www.argo-hytos.com

- Pilot operated check valve sandwich plate for use in stacking assemblies
- 3 models
 - double valve with check valves in lines A and B
 - single valve with check valve in line A
 - single valve with check valve in line B
- Installation dimensions to SO 4401
CETOP - RP 121H and NFPA T3.5.1 - D 02

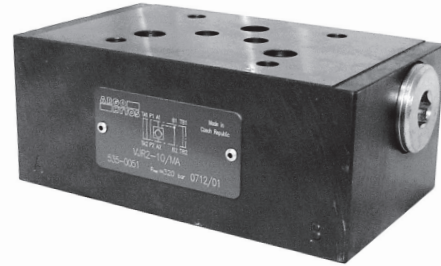
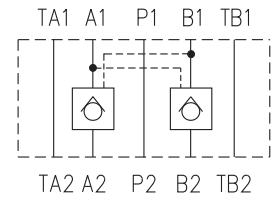

Functional Description

A pilot operated check valve closes tightly the hydraulic circuit between the valve and the actuator. The valve consists of the housing (1), one or two check valves (2), (3) and the pilot piston (4). The main poppets of the check valves are provided with pilot poppets (5) which enable opening the check valve under pressure. When fluid flows from A1 to A2 it opens the check valve (2) and at the same time shifts the pilot piston (4) which opens by means of the pilot poppet (5) the check valve (3). When the pressure in channels A1 and B1 drops, the

springs push the poppets onto the seats and the circuit between the check valve and the actuator is closed under pressure.

To ensure that the check valves close tightly, a directional valve with functional symbol Y is to be used, which connects in its middle position the ports A1 and B1 with tank T (see the typical circuit diagram).

The valve housing (1) is phosphate coated, the surfaces of the other parts are zinc coated.

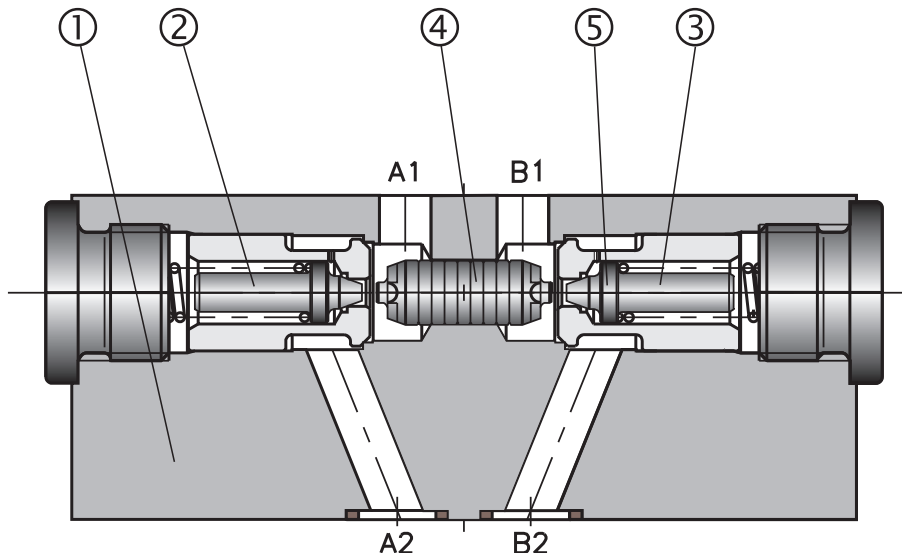

Ordering Code

VJR2-10/M

**Pilot Operated Check Valve
Sandwich Plate**

no designation
V

Seals
NBR
Viton

Valve size **10 (D 05)**

A
B
C

Functional Symbols

Check valve in line A*

Check valve in line B*

Check valves in lines A and B*

* see the table Functional symbols

Modular design

Functional Symbols

Arrangement of the check valves in the valve body

VJR2-10/MA

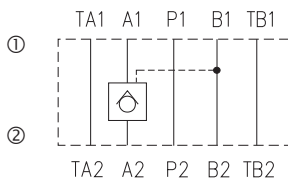

VJR2-10/MB

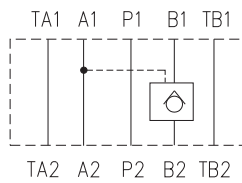

VJR2-10/MC

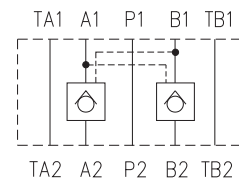

① valve side

② subplate side

Typical circuit with pilot operated check valve

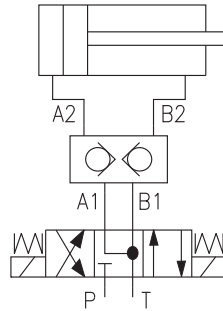

Technical Data

Valve size	mm (US)	10 (D 05)
Maximum flow	L/min (GPM)	100(26.42)
Maximum operating pressure	bar (PSI)	350 (5076)
Cracking pressure	bar (PSI)	2 (29)
Hydraulic fluid	Hydraulic oils of power classes (HL, HLP) to DIN 51524	
Fluid temperature range (NBR)	°C (°F)	-30...+100 (-22 ... +212)
Fluid temperature range (Viton)	°C (°F)	-20...+120 (-4 ... +248)
Viscosity range	mm ² /s (SUS)	20...400 (98 ... 1840)
Maximum degree of fluid contamination	Class 21/18/15 to ISO 4406	
Area ration (pilot piston / seat)	5,6 : 1	
Mounting position	unrestricted	
Weight	kg (lbs)	3 (6.61)

Δp-Q Characteristics

Measured at $v = 32 \text{ mm}^2/\text{s}$ (156 SUS)

Pressure drop Δp related to flow rate.

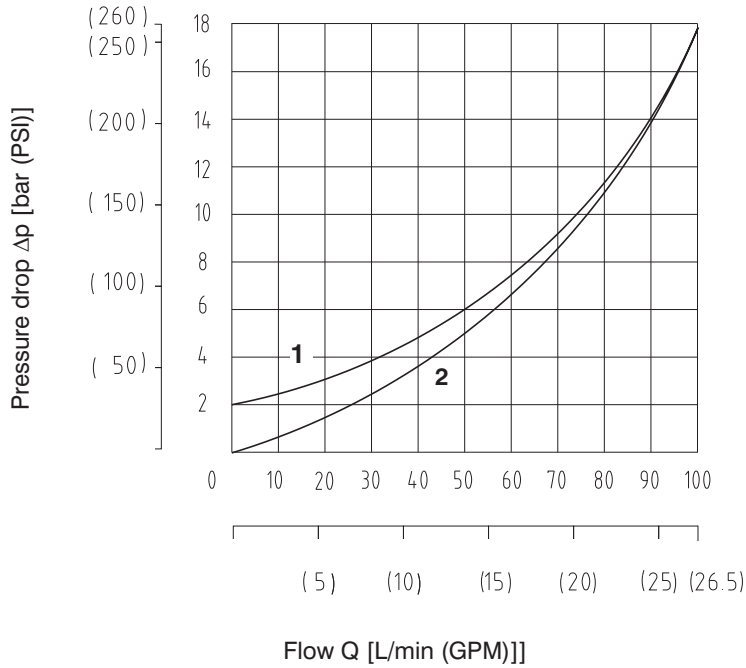

	Flow in direction
1	A1 → A2 (B1 → B2)
2	A2 → A1 (B2 → B1)

Valve Dimensions

Dimensions in millimeters (inches)

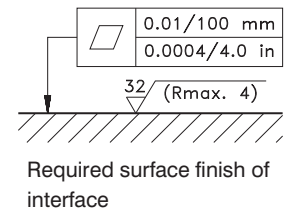
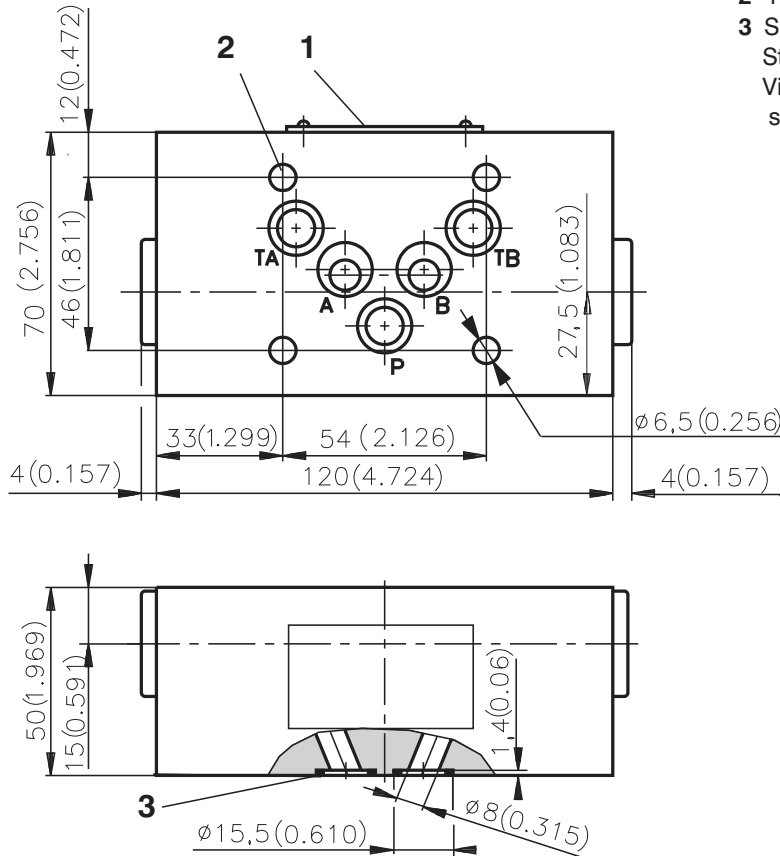

Spare Parts

Dimensions in millimeters

Seal kit

Type	Dimensions, quantity		Ordering number
	O-ring	Square ring	
Standard NBR70	-	12,42x1,68 (5 pcs.)	15991600
Viton	12,42x1,68 (5 pcs.)	-	22943800

Caution!

- The plastic packaging is recyclable.
- Mounting studs must be ordered separately. For stud kits see HU 0040.
- Certified documents are available per request.

ARGO-HYTOS s.r.o. CZ - 543 15 Vrchlaví
 Tel.: +420-499-403111, Fax: +420-499-403421
 E-mail: sales.cz@argo-hytos.com
 www.argo-hytos.com

- Cartridge valve for manifold mounting and with subplate
- Model with subplate - enables direct mounting on the hydraulic actuator by means of a hollow bolt
- The use of a hollow bolt with a build-in throttle VSV1 and check valve possible VSVJ1 and VSVJ2

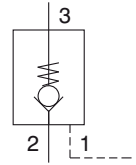

Functional Description

Model RJV1-05 are pilot operated check valves in cartridge design used to give leakfree closure of a hydraulic actuator port under pressure, even during long idle periods.

They basically consist of housing (1), check valve (2), and pilot piston (3). The cartridge is available already assembled into a subplate for direct mounting onto the actuator (page 4 of this data sheet).

When fluid flows from port 2 → 3, it opens the check valve automatically. When the pressure in port 2 drops (e.g. after shifting the directional valve into its middle

position), the spring pushes the ball (2) onto the seat and the circuit between the check valve and the actuator is closed. The control pressure (port 1) acting on the pilot piston (3) moves the ball (2) from the seat and makes the flow passage 3 → 2 free. An additional port 4 is available for use in double acting applications using two pilot operated check valves-see typical circuits (page 3) and drawings (page 5).

The valve body is blackened. The hollow bolt and the surface of the subplate are phosphate coated.

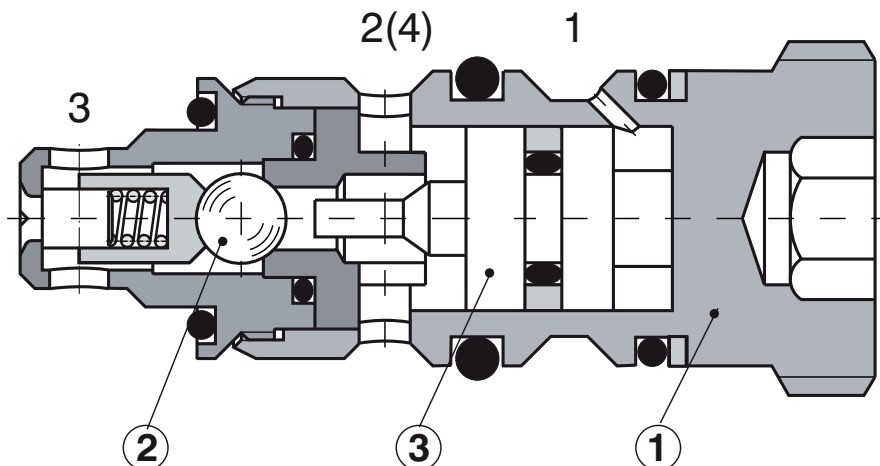

Ordering Code

RJV1-05- /

Pilot Operated Cartridge Check Valve

no designation
V

Seals

NBR
Viton

Nominal size

Model

With pilot piston seal
Without pilot piston seal

no designation
0

Model

Cartridge valve
With subplate - connecting threads
3x M12x1,5 und 1x M18x1,5
With subplate - connecting threads
3x G1/4 und 1x G3/8

no designation
M
G

no designation

S without throttle valve
J1 with flow throttle VSV1
J2 with flow throttle VSVJ1
(fill in just with the model with subplate)

Hollow bolt

Threads of hollow bolt

B
C
D
E

M18x1,5
M22x1,5
G1/2
G3/8
(fill in just with the model with subplate)

Technical Data

Nominal size		05
Maximum flow	L/min (GPM)	20 (5.3)
Maximum operating pressure	bar (PSI)	250 (3600)
Cracking pressure	bar (PSI)	see Δp -Q characteristics
Hydraulic fluid		Hydraulic oils of power classes (HL, HLP) to DIN 51524
Fluid temperature range (NBR)	°C (°F)	-30 ... +100 (-22 ... +212)
Fluid temperature range (Viton)	°C (°F)	-20 ... +120 (-4 ... +248)
Viscosity range	mm ² /s (SUS)	20 ... 400 (98 ... 1840)
Maximum degree of fluid contamination		Class 21/18/15 to ISO 4406
Area ration (pilot piston / seat)		5.76
Weight of the cartridge valve	kg (lbs)	0,08 (0.18)
Mounting position		unrestricted

Hydraulic Circuits

Use of the pilot operated check valve for one direction only (lowering). Port 4 is plugged

Hydraulic circuit with two pilot operated check valves enabling movement in both directions. The use of a directional valve with Y-functional symbol ensures perfect seating of the ball, thus ensuring tight closure of the actuator.

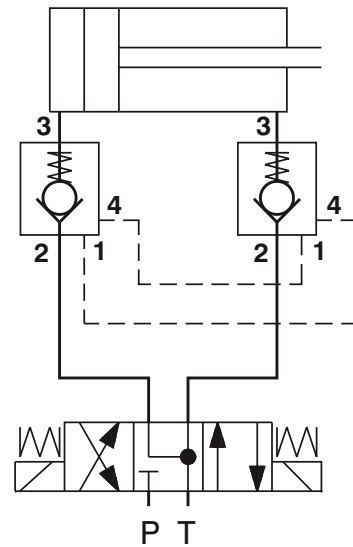
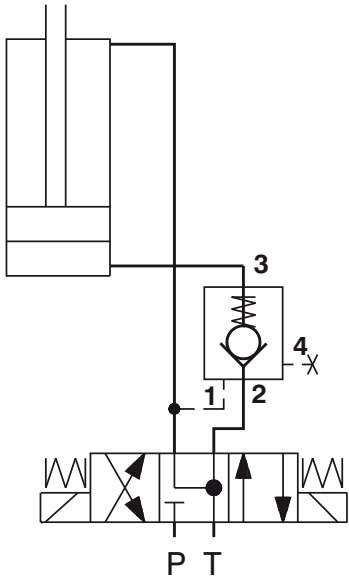

Δp-Q Characteristics

Measured at $v = 32 \text{ mm}^2/\text{s}$ (156 SUS)

Pressure drop Δp related to flow rate.

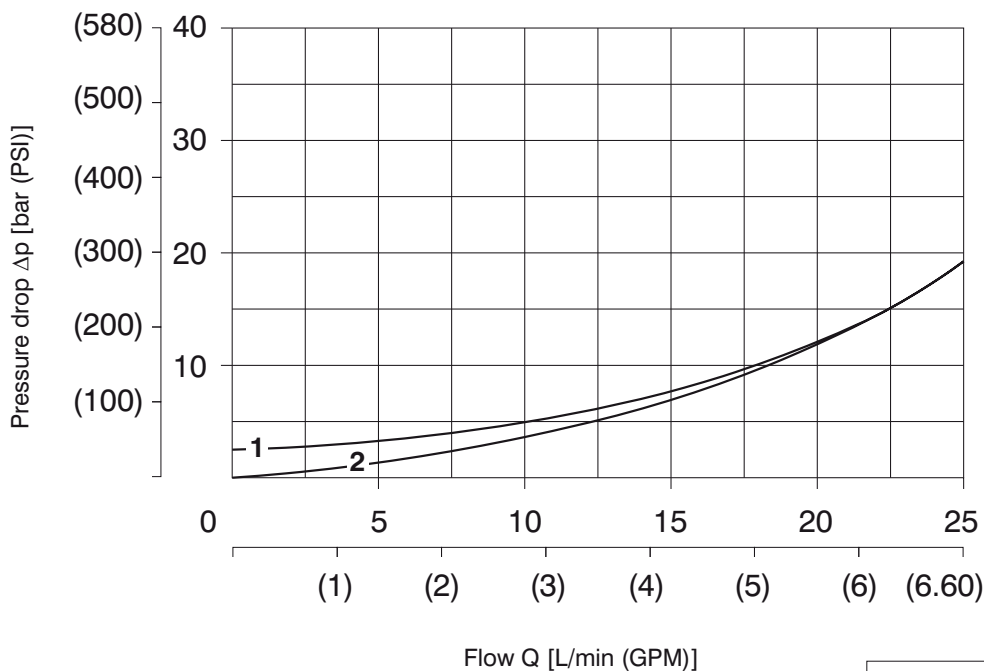

	Flow in direction
1	2 → 3
2	3 → 2

Valve Dimensions

Dimensions in millimeters (inches)

Cartridge valve RJV1-05

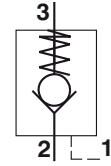
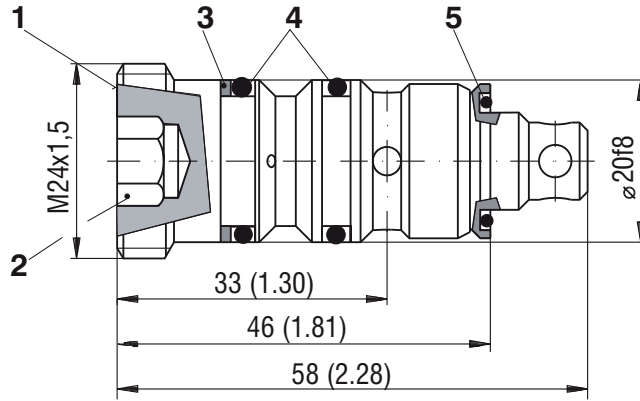

Cavity

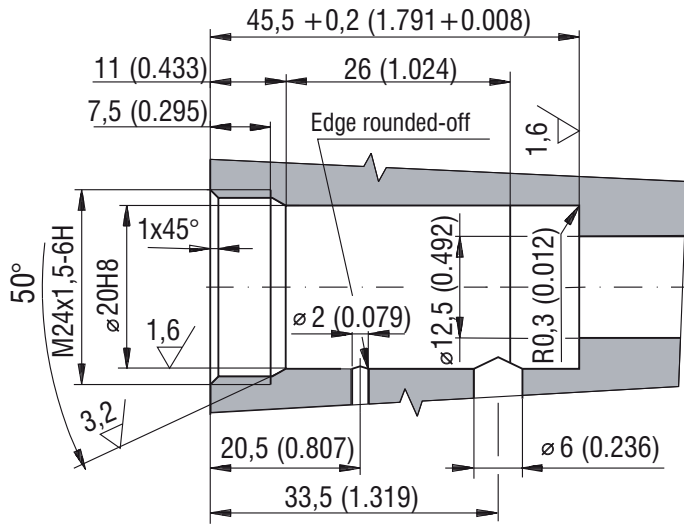

- 1 Type code stamped on the face (RJV1-05)
- 2 Inside HEX 10 (Tightening torque is 10+2 Nm)
- 3 OPKR - BBP80B 113-N9 (14.66 x 19.02 x 1.14)
- 4 O-ring 15.08 x 2.62 (15.54 x 2.62)
- 5 O-ring 12.42 x 1.78

Spare Parts

Dimensions in millimeters

Seal kit

Type	Dimensions, quantity		Ordering number
	O-ring	Back-up ring	
Standard NBR70	12,42 x 1,78 (1 pc.)	14,66 x 19,02 x 1,14 (1 pc.)	15969700
	15,08 x 2,62 (2 pcs.)	-	
Viton	12,42 x 1,78 (1 pc.)	14,66 x 19,02 x 1,14 (1 pc.)	22806000
	15,08 x 2,62 (2 pcs.)	-	

Valve Dimensions

Dimensions in millimeters (inches)

Model with subplate

- Hollow bolt without throttle valve

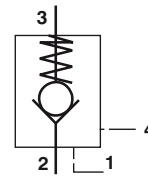
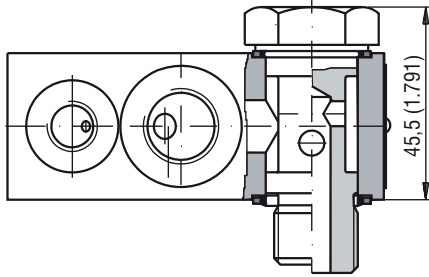

- Hollow bolt with throttle valve VSV1

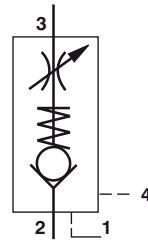
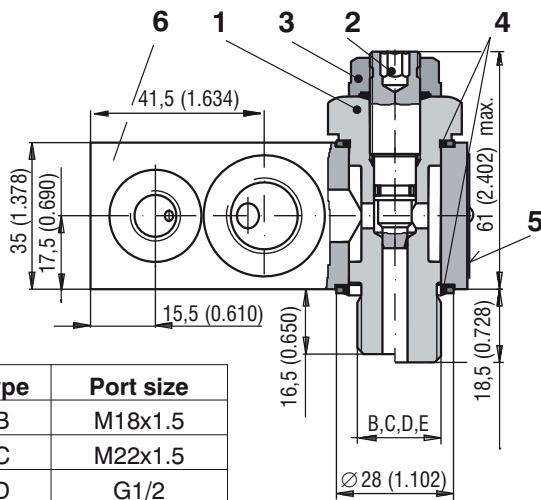

Type	Port size
B	M18x1.5
C	M22x1.5
D	G1/2
E	G3/8

- Hollow bolt with flow throttle and check valve VSVJ1 and VSVJ2

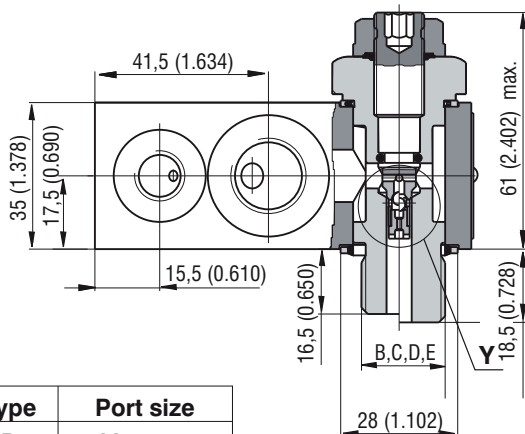

VSVJ1

VSVJ2

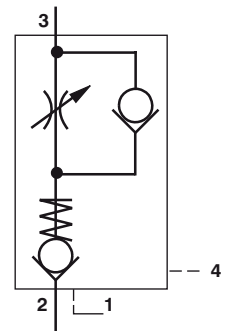
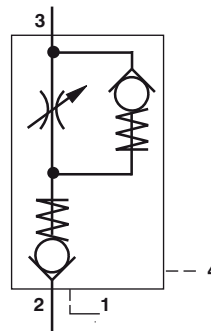

Type	Port size
B	M18x1.5
C	M22x1.5
D	G1/2
E	G3/8

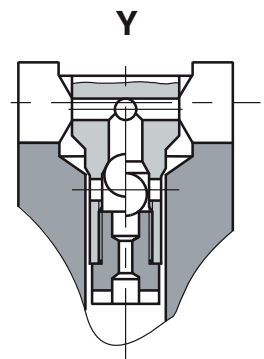
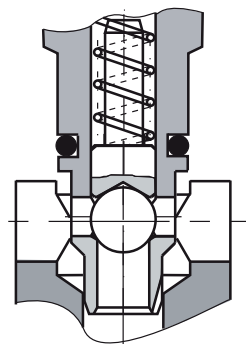

- 1 Hollow bolt (HEX 27)
- 2 Throttle valve VSV1, VSVJ1, VSVJ2 (Inside HEX 6)
- 3 Sealing nut SEAL-LOCK 12 x 1,5 (HEX 19)
- 4 Seal D 22.5 x 28 x 1.5 - NSA
- 5 Type plate
- 6 For optimum positioning the subplate can be turned be 180° (around the check valve axis)

- Dimension scheme of subplate with outlet 1 - 4

Model
M

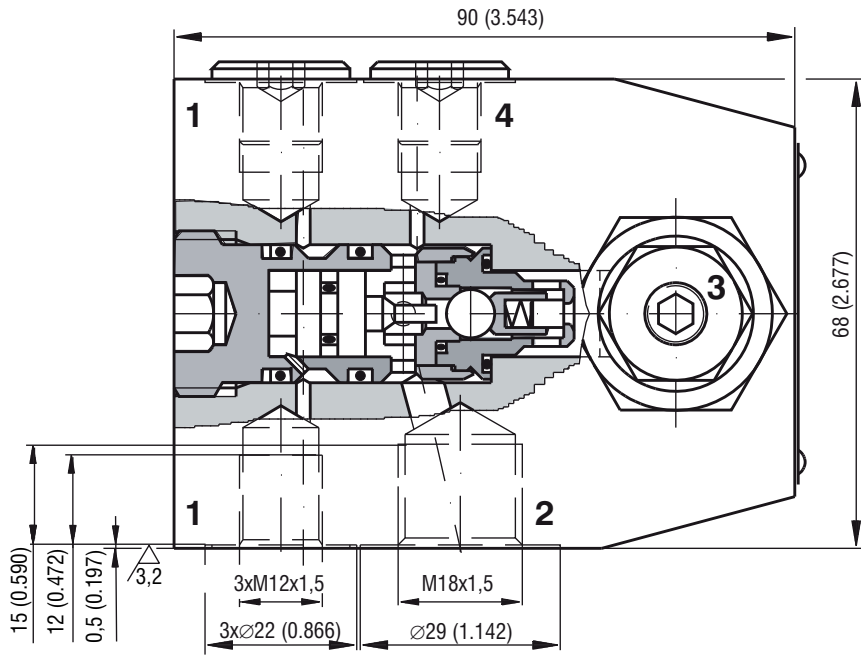

Model
G

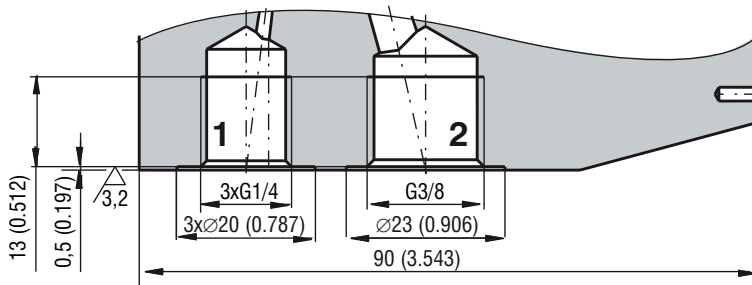

Connecting threads of hollow bolt

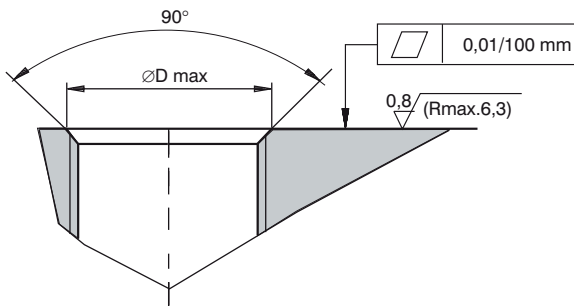

Port size	Ø D max	Tightening torque (Nm)
M18 x 1.5	18 ^{+0.2}	30+3
M22 x 1.5	22 ^{+0.2}	70+5
G 1/2	21 ^{+0.2}	70+5
G 3/8	16.6 ^{+0.2}	25+3

Caution!

- The packing foil is recyclable.
- The technical information regarding the product presented in this catalogue is for descriptive purposes only. It should not be construed in any case as a guaranteed representation of the product properties in the sense of the law.

ARGO-HYTOS s.r.o. CZ - 543 15 Vrchlaví
 Tel.: +420-499-403111, Fax: +420-499-403421
 E-mail: sales.cz@argo-hytos.com
 www.argo-hytos.com

- Load-holding without leakage
- Low pressure drop
- Optional pilot seal
- The valve should be mounted as close as possible to the actuator
- Fits the same cavity as the Q3 overcentre valve

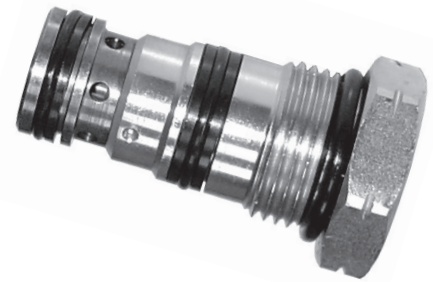
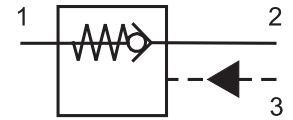

Functional Description

The design of the valve fitted with conical seat ensures hermetical closing in one direction and in the other direction of flow with a small pressure drop. The valve remains shut off closely if the pressure in channel (1) is equal to or higher than the pressure in channel (2) and no pressure and / or insufficient pressure only is exerted in the channel (3). As soon as the pressure in the channel (2) exceeds the pressure in the channel (1) including pressure caused by the spring the valve opens the flow from (2) to (1). If the liquid has to flow through the valve from (1) to (2) the control pressure should be introduced in the channel (3). As soon as this pressure attains a necessary value the control gate valve is shifted against the spring and moves the valve cone out of the seat. At calculating the control pressure

it is necessary to take into consideration that pressure in the channel (2) will increase the control pressure by the same value multiplied by an effective differential area. This effective differential area has a value of $1 - 1/3$ at a rate of control areas of 3:1.

As for appropriate basic surface finish the external parts are zinc coated.

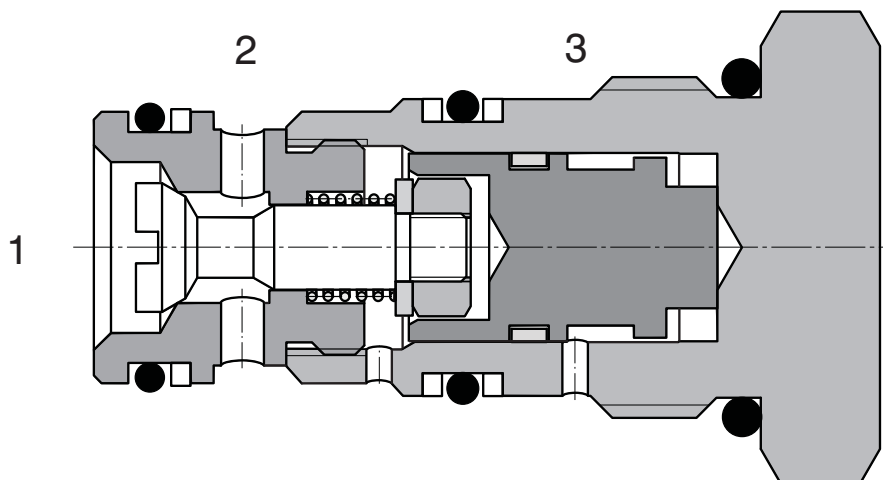

Ordering Code

SC5H-Q3/I

Pilot Operated Check Valve

No designation

Seals
NBR

Pilot ratio
Standard

3:1

3

No designation
S

Optional pilot seal
without seal
with seal

Technical Data

Cavity		M20 x 1.5
Maximum flow	L/min	30
Pilot ratio		3:1
Max. pressure	bar	350
Pressure drops	bar	see $\Delta p - Q$ characteristics
Hydraulic fluid		Hydraulic oil (HM, HV) according to DIN 51524
Fluid temperature range	°C	-20 ... +90
Viscosity	mm ² /s	20 ... 400
Maximum degree of fluid contamination		according to ISO 4406, Class 21/18/15
Weight	kg	0.08
Maximum valve tightening torque in valve body or in control block	Nm	45 ⁺²
Mounting position		Unrestricted

Δp -Q Characteristics

Measured at $v = 40 \text{ mm}^2/\text{s}$

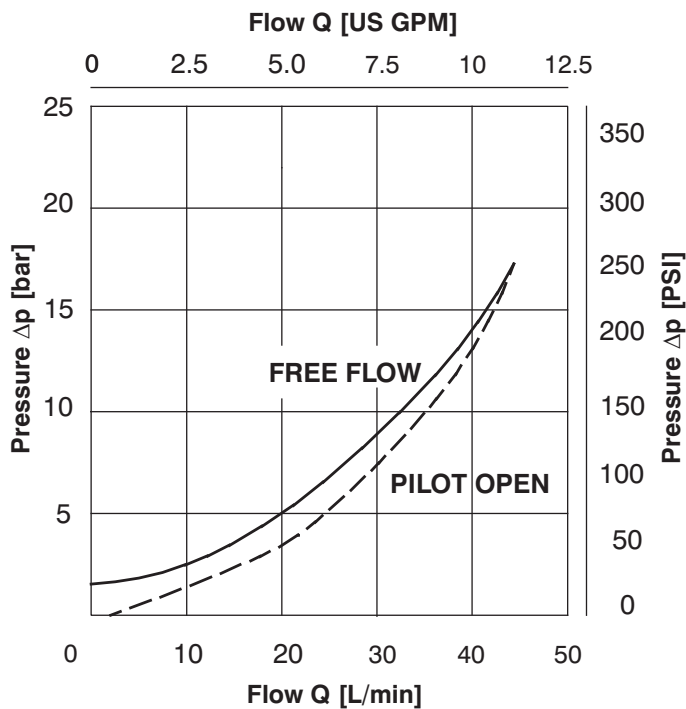

Dimensions

Measurements in millimeters

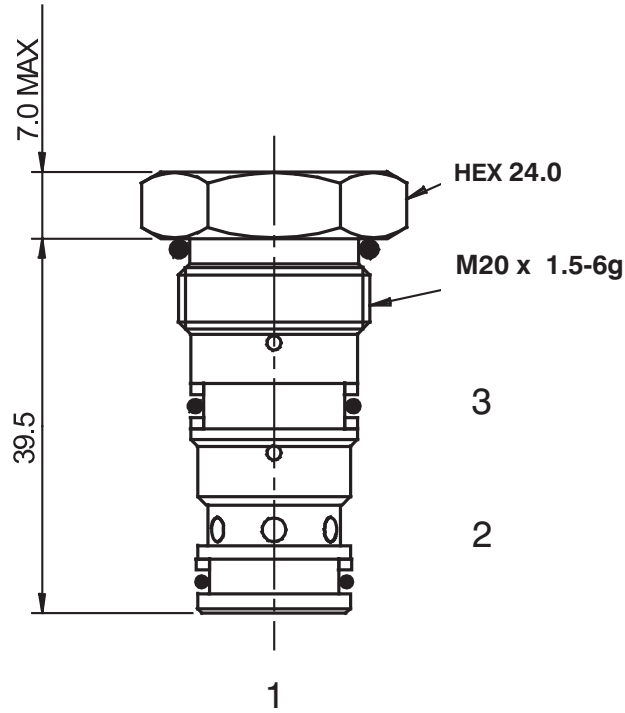

2

Cavity

Measurements in millimeters

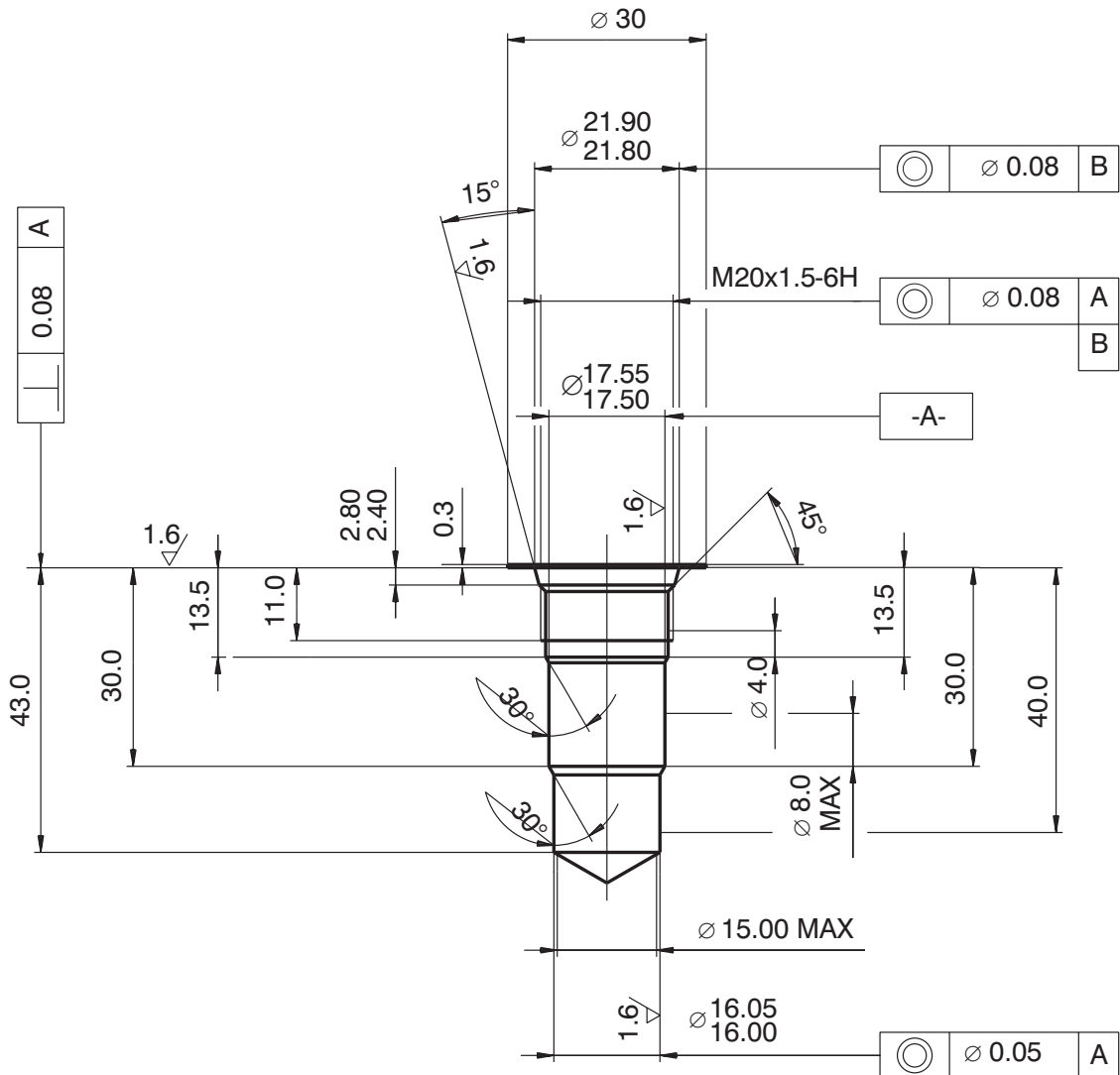

Valve Bodies

Measurements in millimeters

2

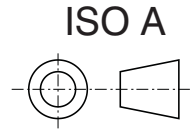
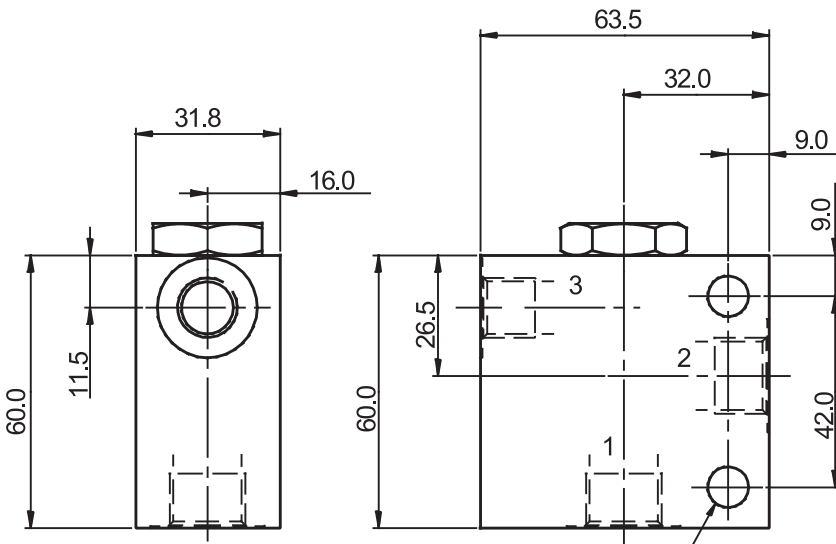

2x HOLES Ø 9.0 THRO'

Body without valve			
Material	Ports	Port size	Type code
Aluminium	1, 2	G3/8	SB-Q3-0103AL
	3	G1/4	
	1, 2	SAE 8, 3/4-16	SB-Q3-0104AL
	3	SAE 6, 9/16-18	
Steel	1, 2	G3/8	SB-Q3-0103ST
	3	G1/4	
	1, 2	SAE 8, 3/4-16	SB-Q3-0104ST
	3	SAE 6, 9/16-18	

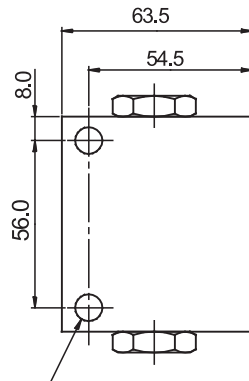
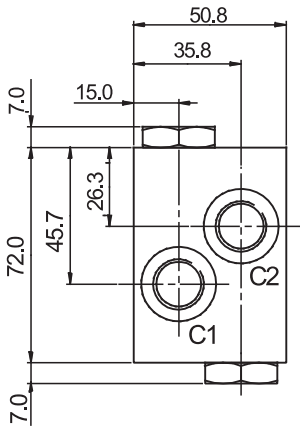

2x HOLES Ø 9.0 THRO'

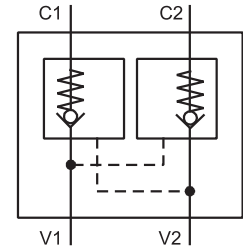
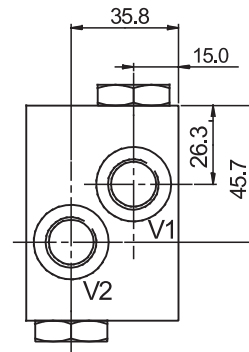

Dual body without valve			
Material	Ports	Port size	Type code
Aluminium	C1, C2, V1, V2	G3/8	SB-Q4-0303AL
	C1, C2, V1, V2	SAE 8, 3/4-16	SB-Q4-0304AL
Steel	C1, C2, V1, V2	G3/8	SB-Q4-0303ST
	C1, C2, V1, V2	SAE 8, 3/4-16	SB-Q4-0304ST

The use of aluminium bodies is limited to a maximum operating pressure of 210 bar.

Spare Parts

Seal kits on request.

Caution!

- The packing foil is recyclable.
- The technical information regarding the product presented in this catalogue is for descriptive purposes only. It should not be construed in any case as a guaranteed representation of the product properties in the sense of the law.

ARGO-HYTOS s.r.o. CZ - 543 15 Vrchlaví
 Tel.: +420-499-403111, Fax: +420-499-403421
 E-mail: sales.cz@argo-hytos.com
 www.argo-hytos.com

- Load-holding without leakage
- Low pressure drop
- Optional pilot seal
- The valve should be mounted as close as possible to the actuator
- Fits the same cavity as the R3 overcentre valve

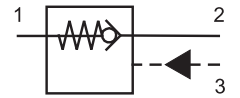

Functional Description

The design of the valve fitted with conical seat ensures hermetical closing in one direction and in the other direction of flow with a small pressure drop. The valve remains shut off closely if the pressure in channel (1) is equal to or higher than the pressure in channel (2) and no pressure and / or insufficient pressure only is exerted in the channel (3). As soon as the pressure in the channel (2) exceeds the pressure in the channel (1) including pressure caused by the spring the valve opens the flow from (2) to (1). If the liquid has to flow through the valve from (1) to (2) the control pressure should be introduced in the channel (3). As soon as this pressure attains a necessary value the control gate valve is shifted against the spring and moves the valve cone out of the seat. At calculating the control pressure

it is necessary to take into consideration that pressure in the channel (2) will increase the control pressure by the same value multiplied by an effective differential area. This effective differential area has a value of $1 - 1/4$ at a rate of control areas of 4:1.

As for appropriate basic surface finish the external parts are zinc coated.

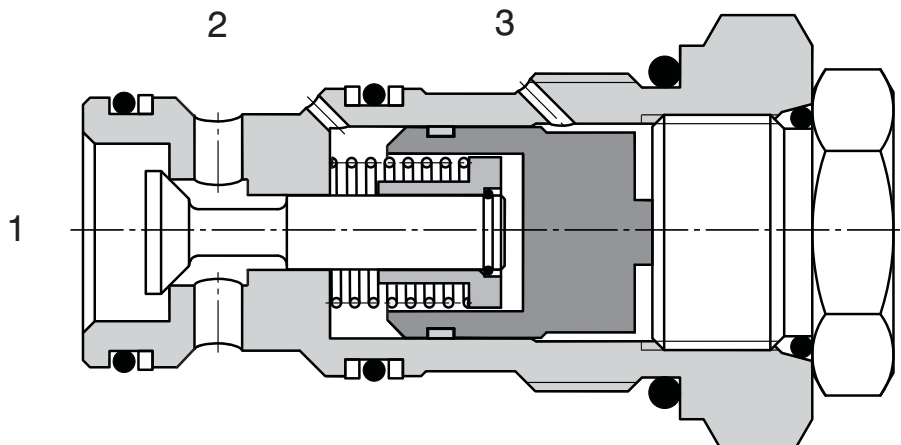

Ordering Code

SC5H-R3/I

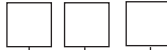

Pilot Operated Check Valve

No designation

Seals
NBR

Pilot ratio
Standard

4:1

4

No designation
S

Optional pilot seal
without seal
with seal

Technical Data

Cavity		M27 x 1.5
Maximum flow	L/min	90
Pilot ratio		4:1
Max. pressure	bar	350
Pressure drops	bar	see $\Delta p - Q$ characteristics
Hydraulic fluid		Hydraulic oil (HM, HV) according to DIN 51524
Fluid temperature range	°C	-20 ... +90
Viscosity	mm ² /s	20 ... 400
Maximum degree of fluid contamination		according to ISO 4406, Class 21/18/15
Weight	kg	0.27
Maximum valve tightening torque in valve body or in control block	Nm	60 ⁺²
Mounting position		Unrestricted

Δp -Q Characteristics

Measured at $v = 40 \text{ mm}^2/\text{s}$

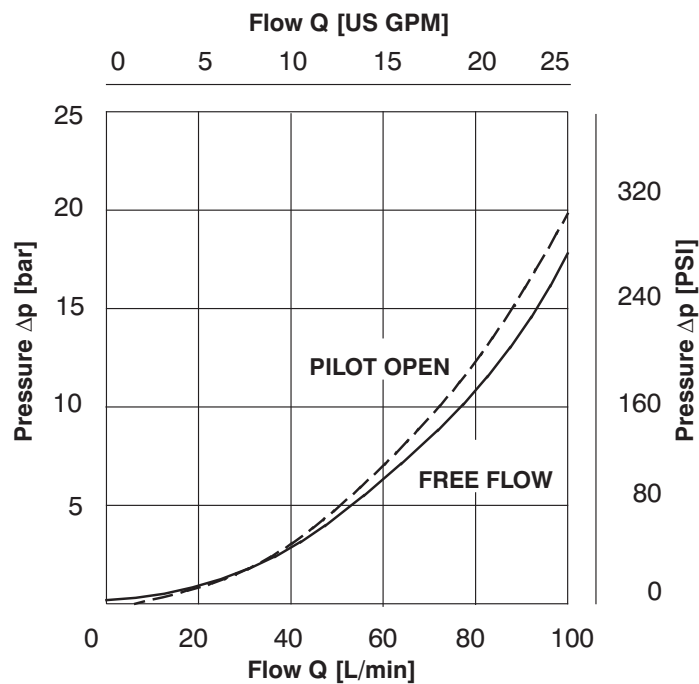

Dimensions

Measurements in millimeters

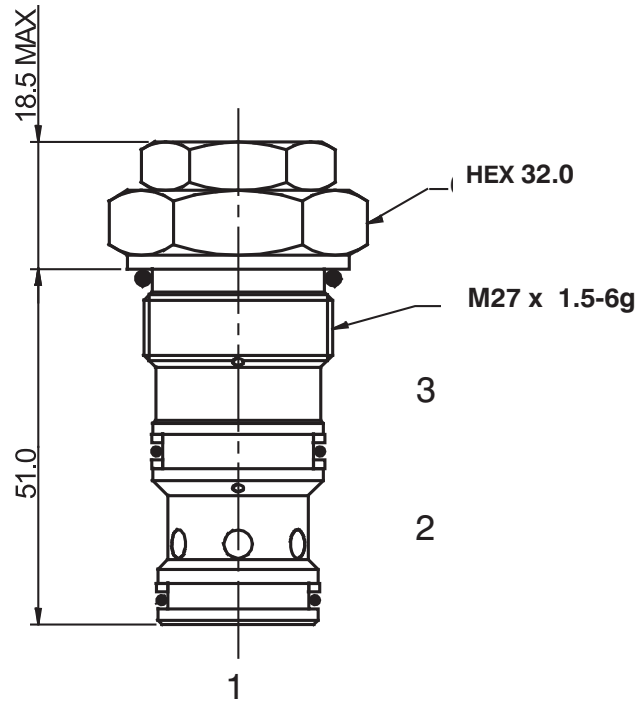

2

Cavity

Measurements in millimeters

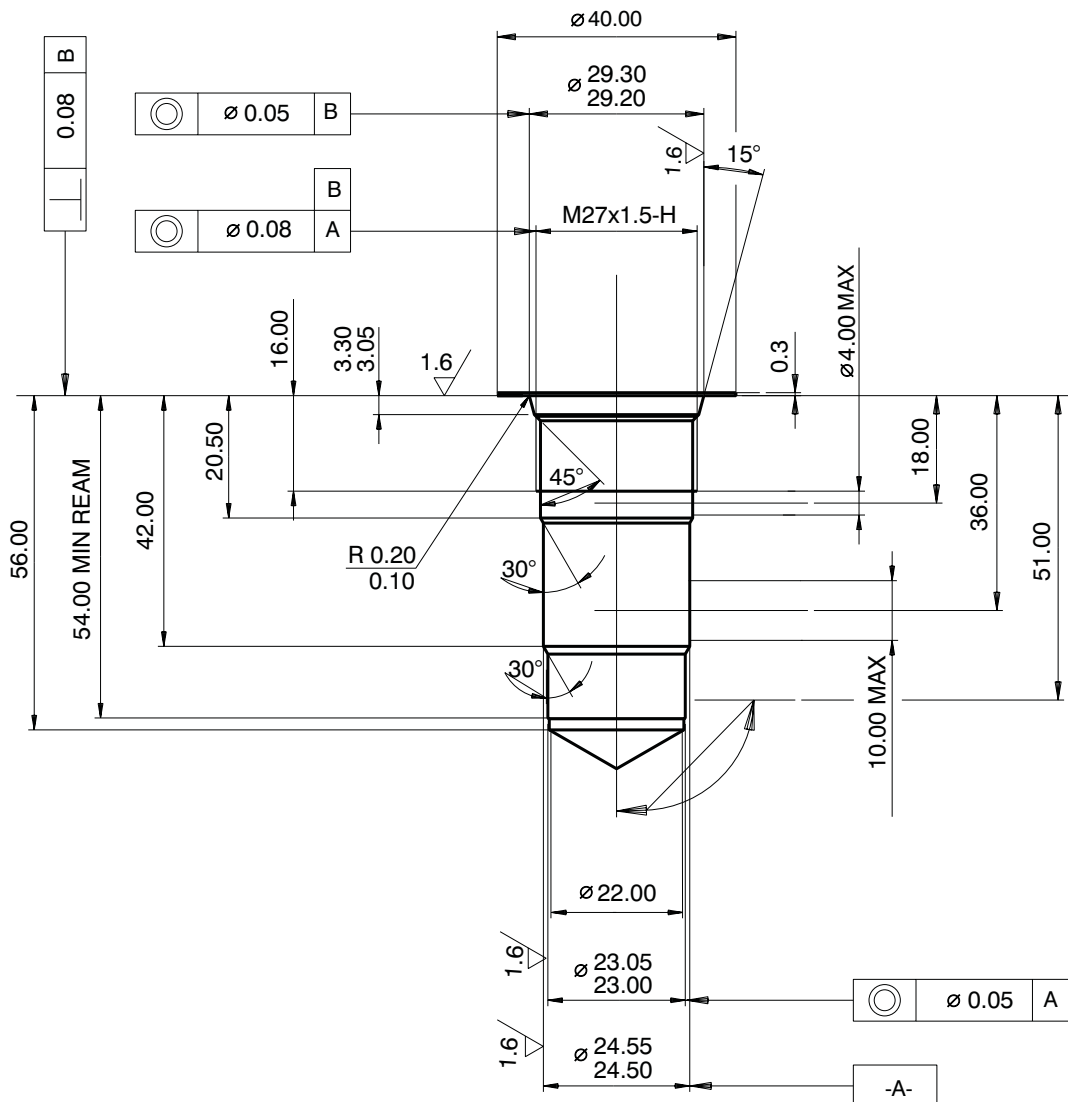

Valve Bodies

Measurements in millimeters

ISO A

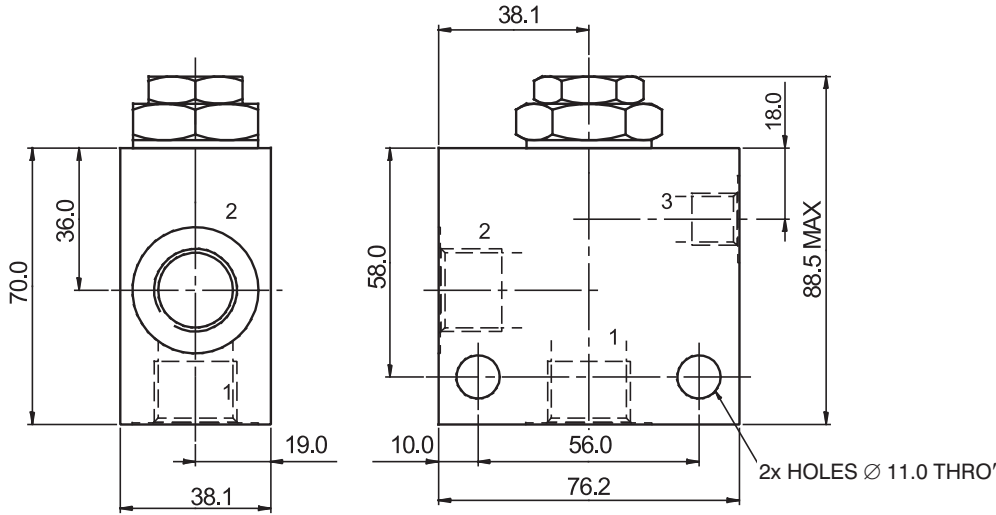
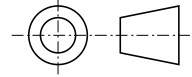

Body without valve			
Material	Ports	Port size	Type code
Aluminium	1, 2	G1/2	SB-R3-0105AL
	3	G1/4	
	1, 2	SAE 10, 7/8-14	SB-R3-0106AL
	3	SAE 6, 9/16-18	
Steel	1, 2	G1/2	SB-R3-0105ST
	3	G1/4	
	1, 2	SAE 10, 7/8-14	SB-R3-0106ST
	3	SAE 6, 9/16-18	

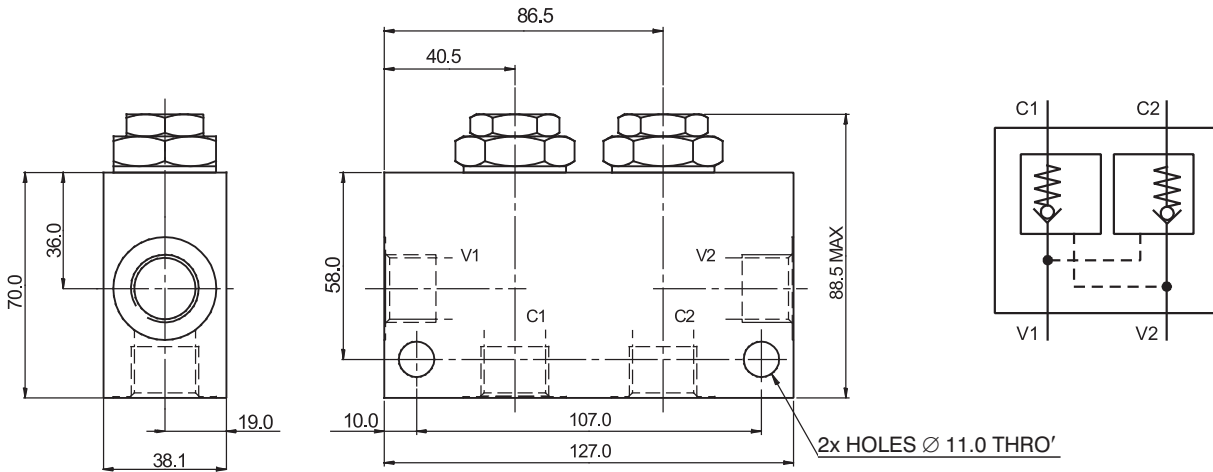

Dual body without valve			
Material	Ports	Port size	Type code
Aluminium	C1, C2, V1, V2	G1/2	SB-R4-0205AL
	C1, C2, V1, V2	SAE 10, 7/8-14	SB-R4-0206AL
Steel	C1, C2, V1, V2	G1/2	SB-R4-0205ST
	C1, C2, V1, V2	SAE 10, 7/8-14	SB-R4-0206ST

The use of aluminium bodies is limited to a maximum operating pressure of 210 bar.

Spare Parts

Seal kits on request.

Caution!

- The packing foil is recyclable.
- The technical information regarding the product presented in this catalogue is for descriptive purposes only. It should not be construed in any case as a guaranteed representation of the product properties in the sense of the law.

ARGO-HYTOS s.r.o. CZ - 543 15 Vrchlabí
 Tel.: +420-499-403111, Fax: +420-499-403421
 E-mail: sales.cz@argo-hytos.com
 www.argo-hytos.com

- Load-holding without leakage
- Low pressure drop
- Decompression stage
- Optional pilot seal
- The valve should be mounted as close as possible to the actuator
- Fits the same cavity as the R3 overcentre valve

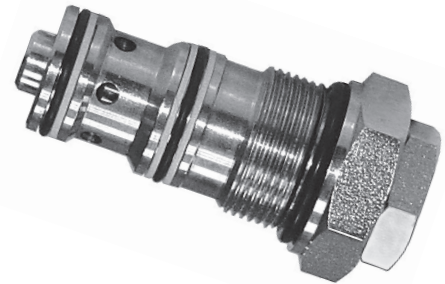
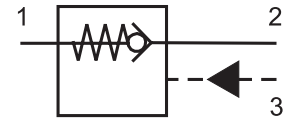

Functional Description

The design of the valve fitted with conical seat ensures hermetical closing in one direction and in the other direction of flow with a small pressure drop. In this case the question is an indirectly controlled one-way valve opened hydraulically. The closing element (valve cone of the main stage of the valve) and a ball (of the control stage) are pressed to the seat of the valve by the spring force. If the channel (2) pressure exceeds the spring pressure and pressure in the channel (1) the liquid flows through the valve opened. The appropriate pressure drops are identified on the characteristics as a free rate of flow. In the case of this direction of flow the valve operates as a simple one-way valve.

In the opposite direction the liquid can flow from the -channel (1) to the channel (2) in the case a sufficient control pressure acts in the channel (3) only.

Opening pressure = $\frac{\text{Pressure of channel (1)}}{25}$
of the control stage
(decompression)

By opening a small amount the control valve the pressure in the channel (2) is dropped in such extent that the control pressure in the channel (3) is sufficient for opening the main stage.

Opening pressure of the main stage = $\frac{\text{Pressure of channel (1)}}{3}$

Pressure drop values at the main stage opened are identified in the flow characteristics as open by the control.

During computing the control pressure it is necessary to take into consideration that pressure acting in the channel (2) increases the control pressure by the same value multiplied by the effective differential area having a value of 1 – 1/25 in case of a value of the ratio of control surfaces of 25:1.

As for appropriate basic surface finish the external parts are zinc coated.

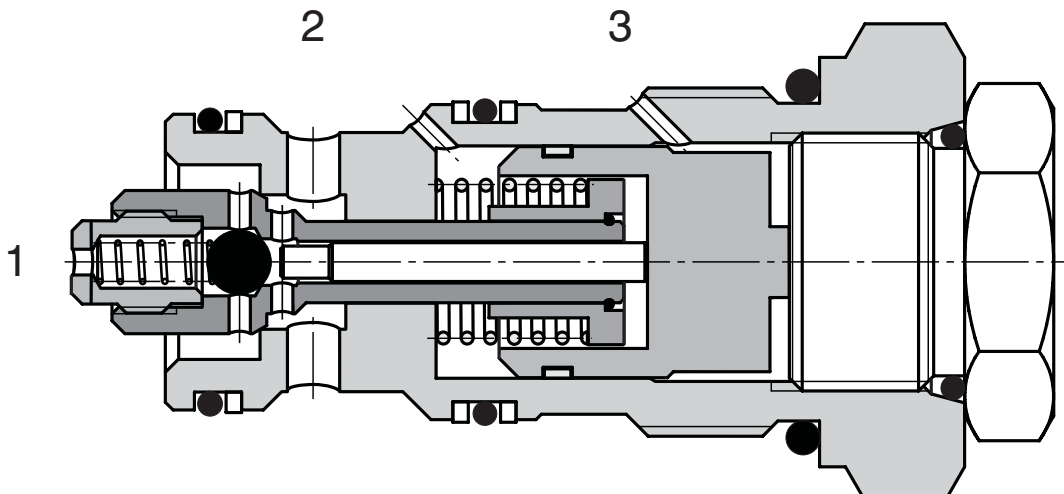

Ordering Code

2

SC5H-R3/I

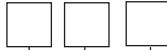

Pilot Operated Check Valve
with decompression

No designation

Seals
NBR

Pilot ratio

Decompression 25:1
Full flow 3:1

3

No designation

S

Optional pilot seal

without seal
with seal

Technical Data

Cavity		M27 x 1.5
Maximum flow	L/min	90
Pilot ratio decompression		25:1
Pilot ratio full flow		3:1
Max. pressure	bar	350
Pressure drops	bar	see $\Delta p - Q$ characteristics
Hydraulic fluid		Hydraulic oil (HM, HV) according to DIN 51524
Fluid temperature range	°C	-20 ... +90
Viscosity	mm ² /s	20 ... 400
Maximum degree of fluid contamination		According to ISO 4406, Class 21/18/15
Weight	kg	0.24
Maximum valve tightening torque in valve body or in control block	Nm	60 ⁺²
Mounting position		Unrestricted

$\Delta p - Q$ Characteristics

Measured at $v = 40 \text{ mm}^2/\text{s}$

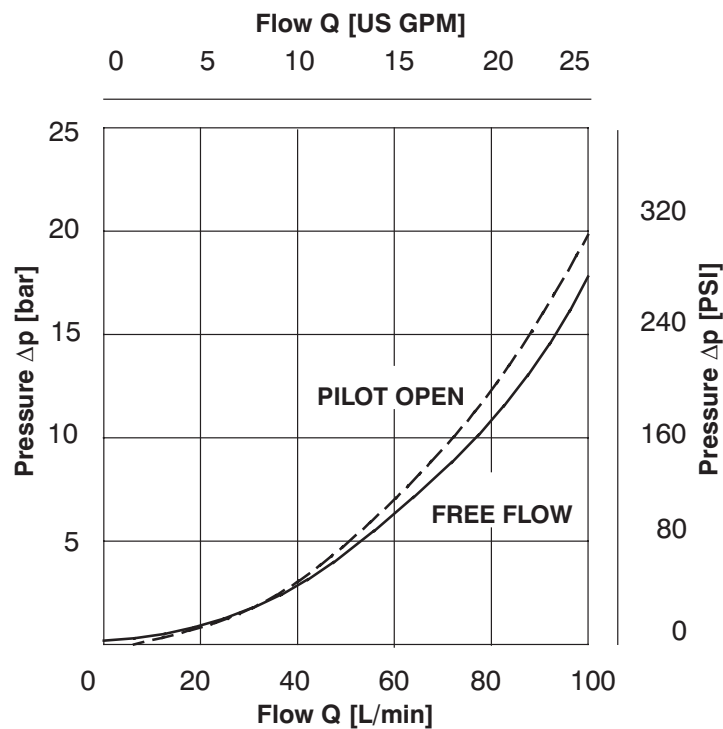

Dimensions

Measurements in millimeters

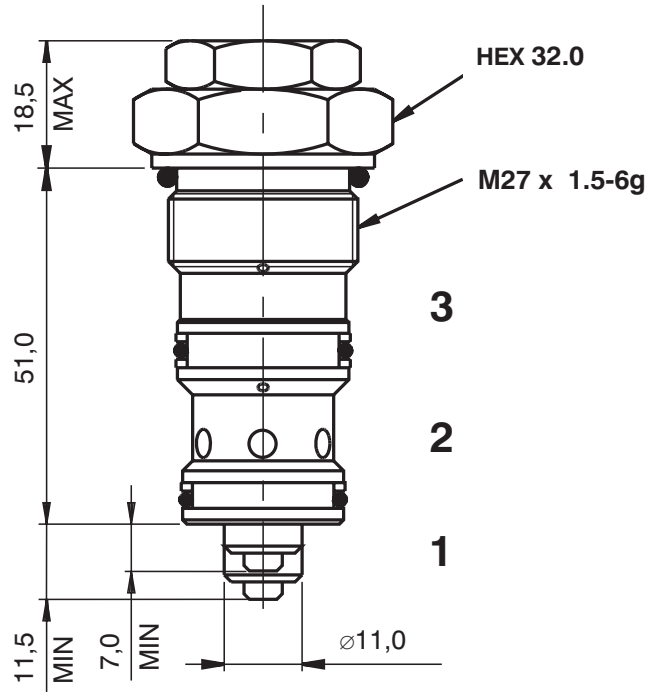

2

Cavity

Measurements in millimeters

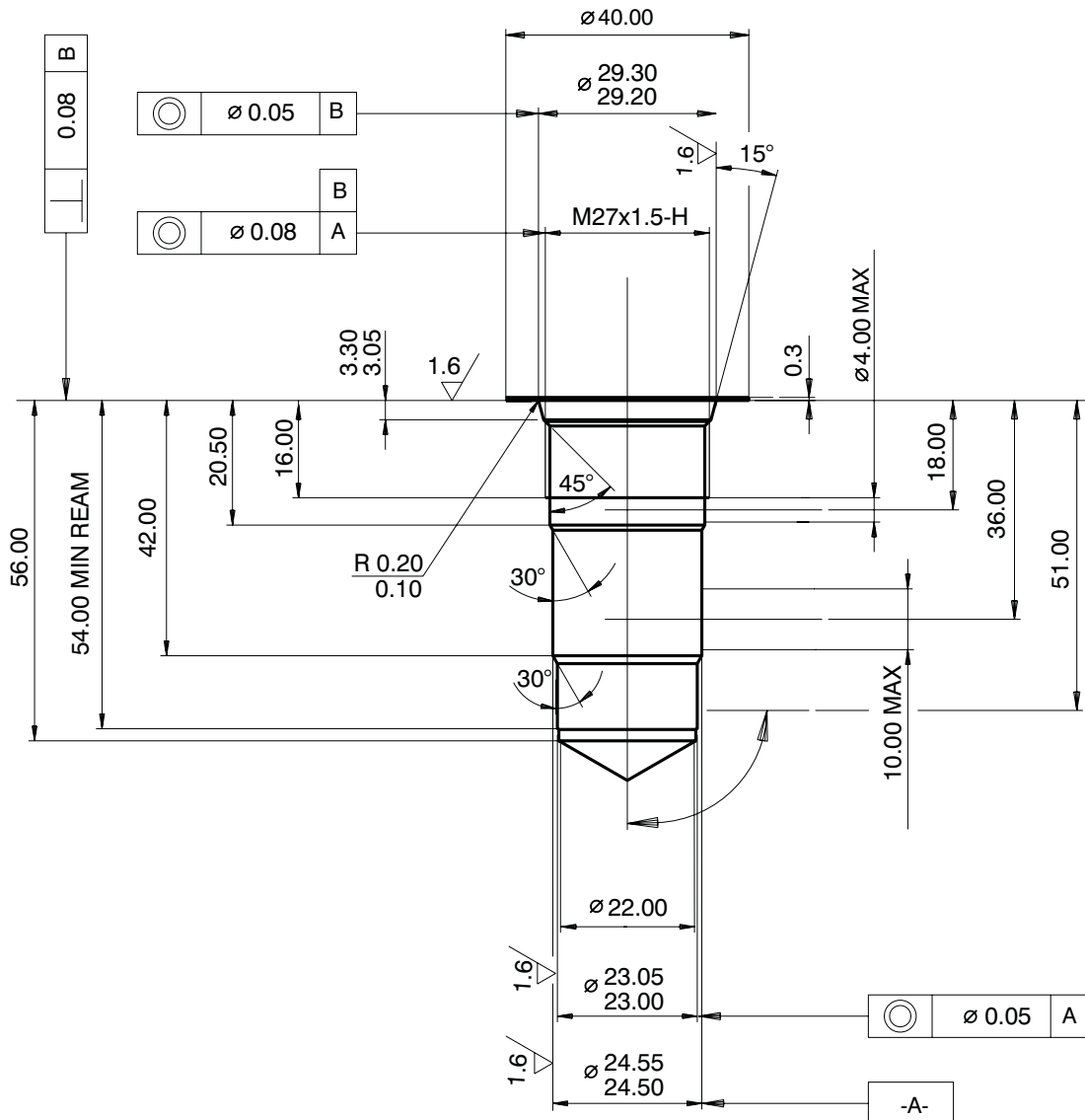

Valve Bodies

Measurements in millimeters

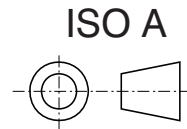
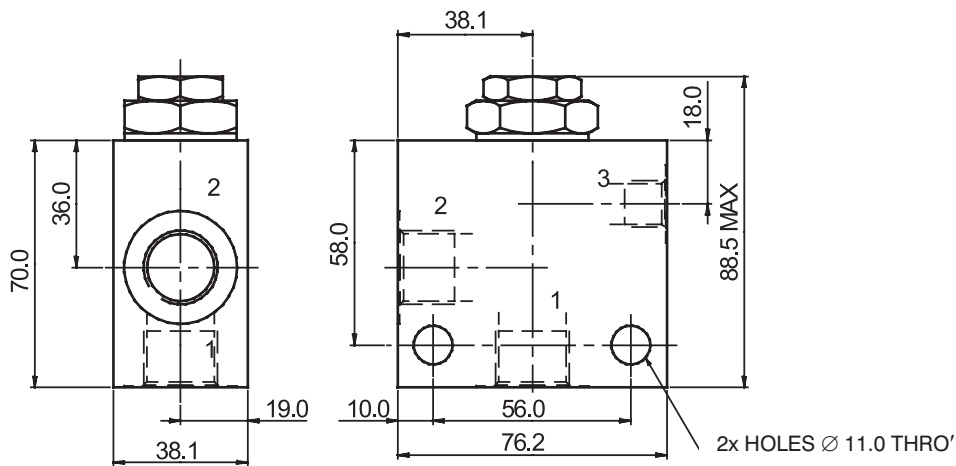

Body without valve			
Material	Ports	Port size	Type code
Aluminium	1, 2	G1/2	SB-R3-0105AL
	3	G1/4	
	1, 2	SAE 10, 7/8-14	SB-R3-0106AL
	3	SAE 6, 9/16-18	
Steel	1, 2	G1/2	SB-R3-0105ST
	3	G1/4	
	1, 2	SAE 10, 7/8-14	SB-R3-0106ST
	3	SAE 6, 9/16-18	

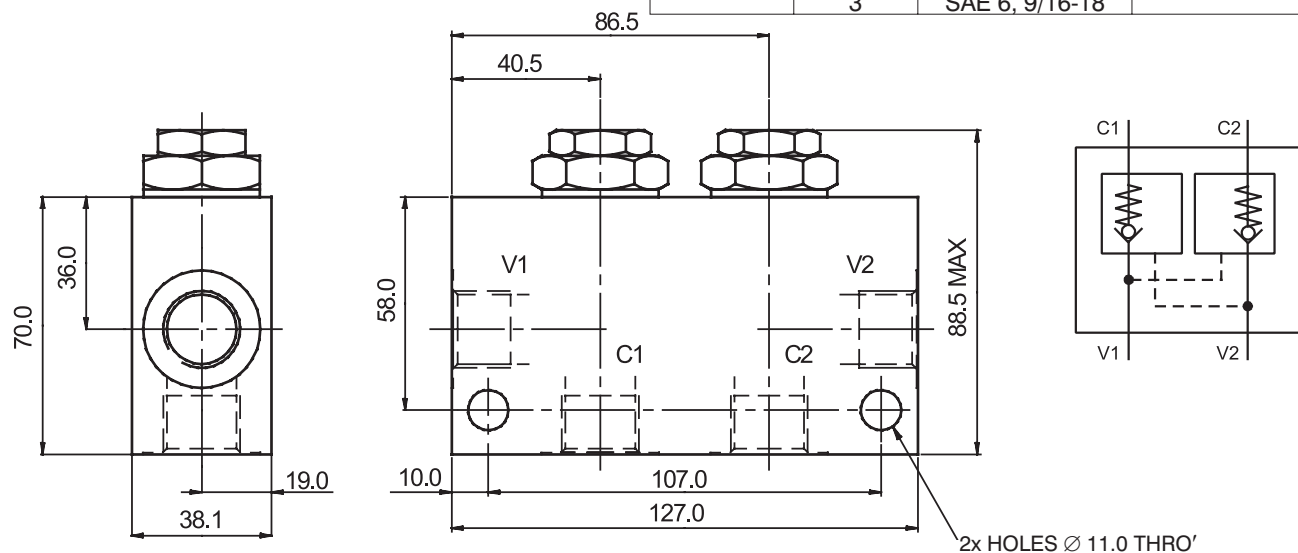

Dual body without valve			
Material	Ports	Port size	Type code
Aluminium	C1, C2, V1, V2	G1/2	SB-R4-0205AL
	C1, C2, V1, V2	SAE 10, 7/8-14	SB-R4-0206AL
Steel	C1, C2, V1, V2	G1/2	SB-R4-0205ST
	C1, C2, V1, V2	SAE 10, 7/8-14	SB-R4-0206ST

The use of aluminium bodies is limited to a maximum operating pressure of 210 bar.

Spare Parts

Seal kits on request.

Caution!

- The packing foil is recyclable.
- The technical information regarding the product presented in this catalogue is for descriptive purposes only. It should not be construed in any case as a guaranteed representation of the product properties in the sense of the law.

ARGO-HYTOS s.r.o. CZ - 543 15 Vrchlabí
 Tel.: +420-499-403111, Fax: +420-499-403421
 E-mail: sales.cz@argo-hytos.com
 www.argo-hytos.com

- Load-holding without leakage
- Low pressure drop
- Optional pilot seal
- The valve should be mounted as close as possible to the actuator
- Fits the same cavity as the S3 overcentre valve

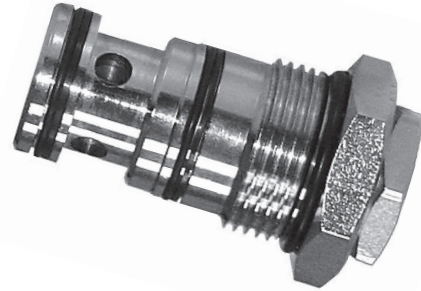
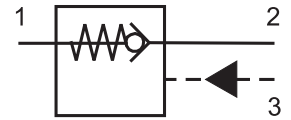

Functional Description

The design of the valve fitted with conical seat ensures hermetical closing in one direction and in the other direction of flow with a small pressure drop. The valve remains shut off closely if the pressure in channel (1) is equal to or higher than the pressure in channel (2) and no pressure and / or insufficient pressure only is exerted in the channel (3). As soon as the pressure in the channel (2) exceeds the pressure in the channel (1) including pressure caused by the spring the valve opens the flow from (2) to (1). If the liquid has to flow through the valve from (1) to (2) the control pressure should be introduced in the channel (3). As soon as this pressure attains a necessary value the control gate valve is shifted against the spring and moves the valve cone out of the seat. At calculating the control pressure it is necessary to take

into consideration that pressure in the channel (2) will increase the control pressure by the same value multiplied by an effective differential area. This effective differential area has a value of $1 - 1/3$ at a rate of control areas of 3:1.

As for appropriate basic surface finish the external parts are zinc coated.

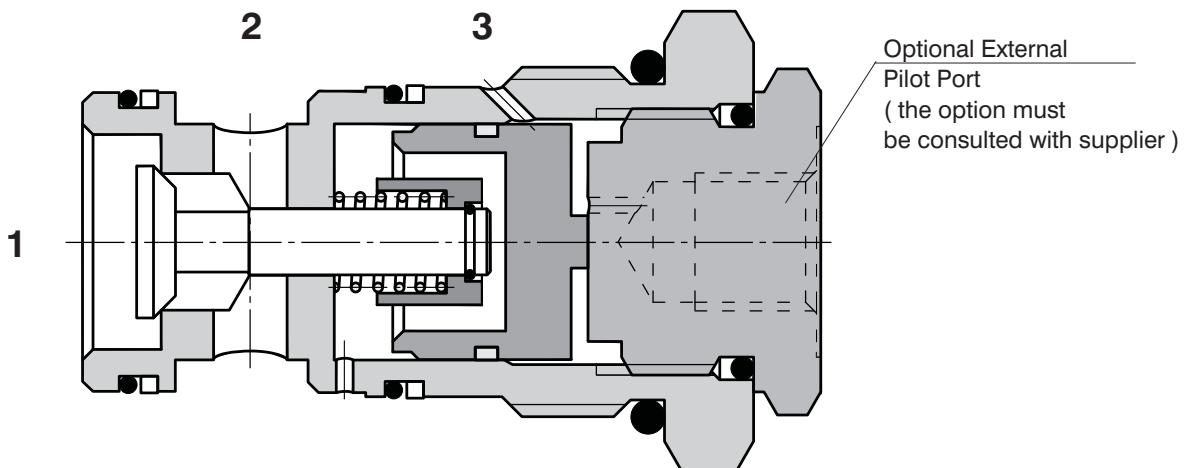

Ordering Code

SC5H-S3/I

Pilot Operated Check Valve

No designation

Seals
NBR

Pilot ratio

Standard

3:1

3

No designation

S

Optional pilot seal

without seal

wit seal

Technical Data

Cavity		1-5/16-12 UN-2A
Maximum flow	L/min	120
Pilot ratio		3:1
Max. pressure	bar	350
Pressure drops	bar	see $\Delta p - Q$ characteristics
Hydraulic fluid		Hydraulic oil (HM, HV) according to DIN 51524
Fluid temperature range	°C	-20 ... +90
Viscosity	mm ² /s	20 ... 400
Maximum degree of fluid contamination		According to ISO 4406, Class 21/18/15
Weight	kg	0.28
Maximum valve tightening torque in valve body or in control block	Nm	100 ⁺²
Mounting position		Unrestricted

Δp -Q Characteristics

Measured at $v = 40 \text{ mm}^2/\text{s}$

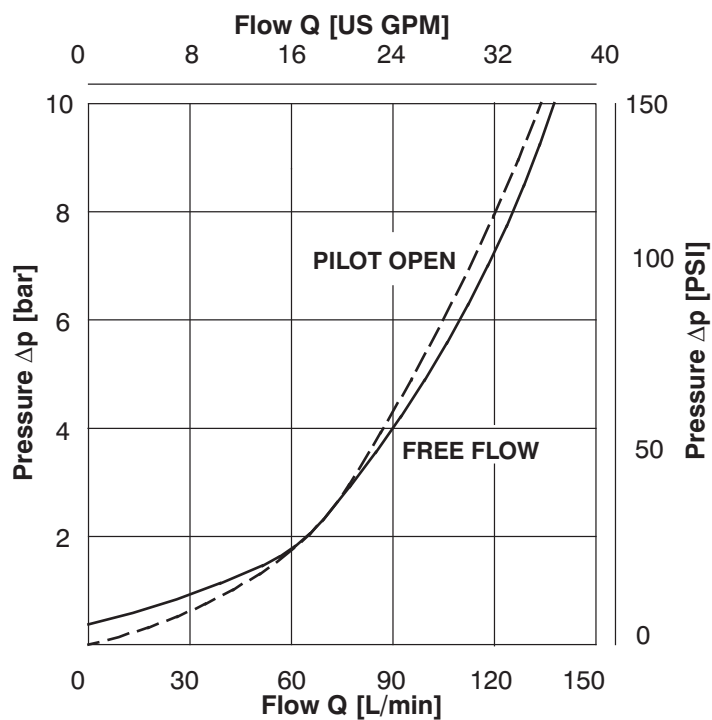

Dimensions

Measurements in millimeters

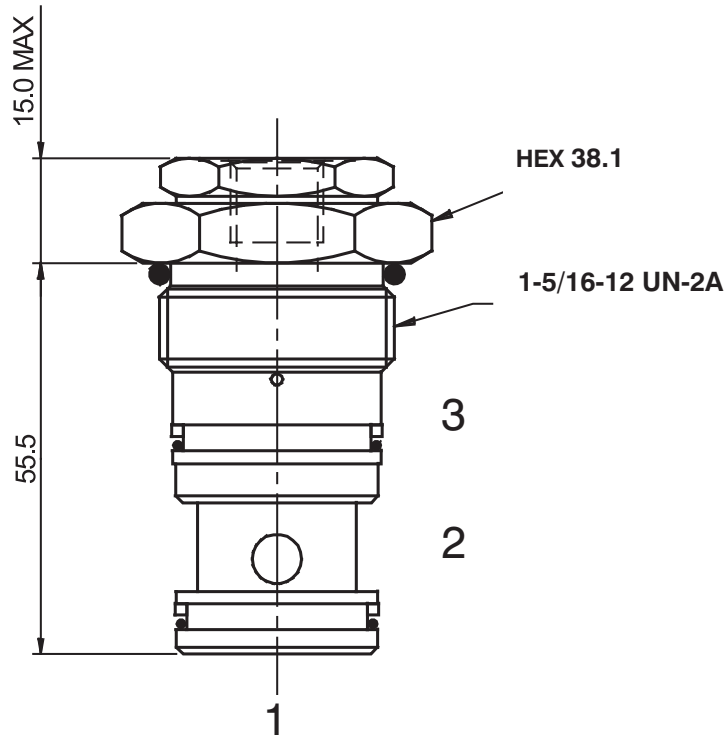

2

Cavity

Measurements in millimeters

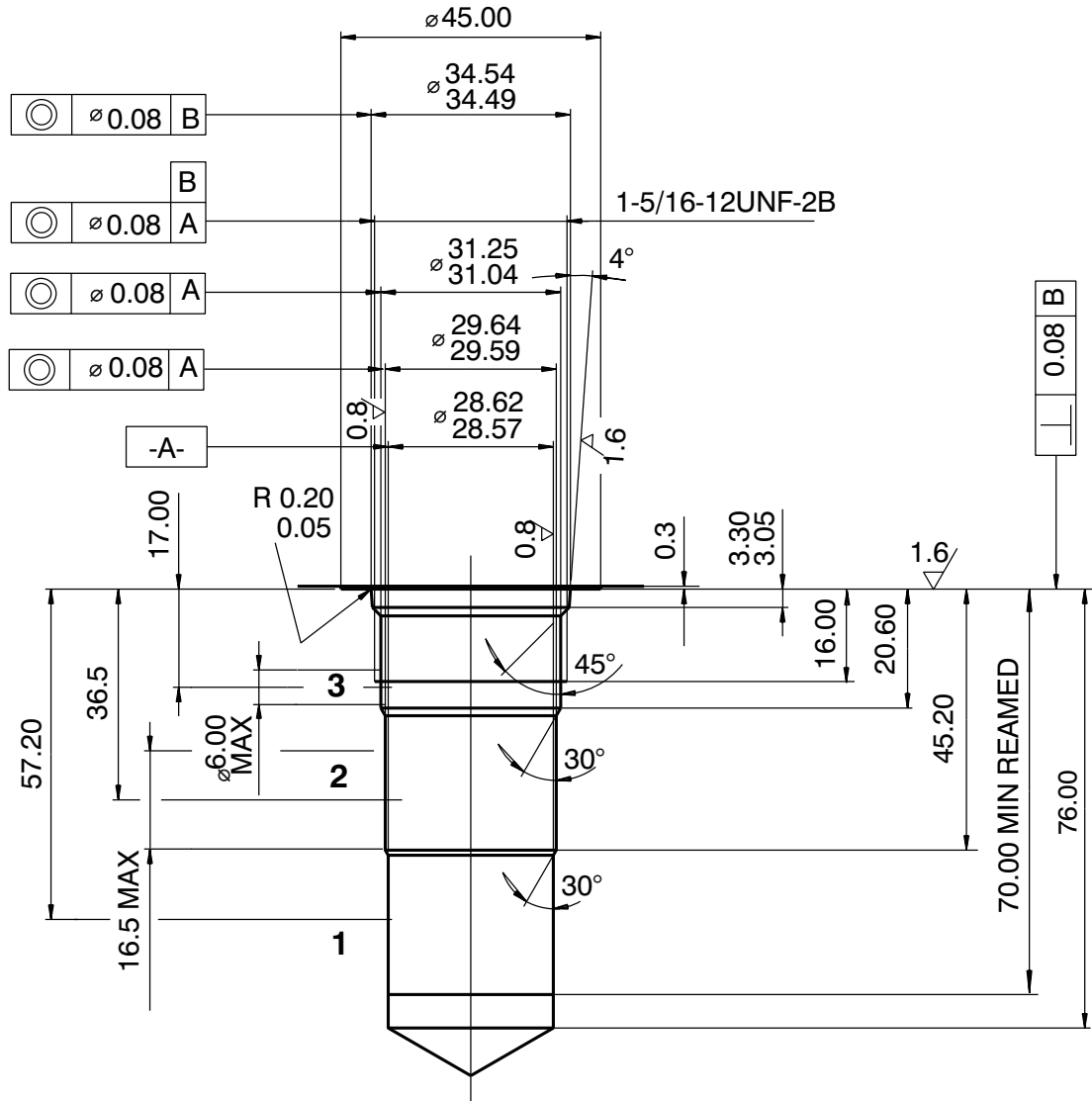

Valve Bodies

Measurements in millimeters

2

2x HOLES Ø 10.5 THRO'

ISO A

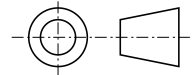
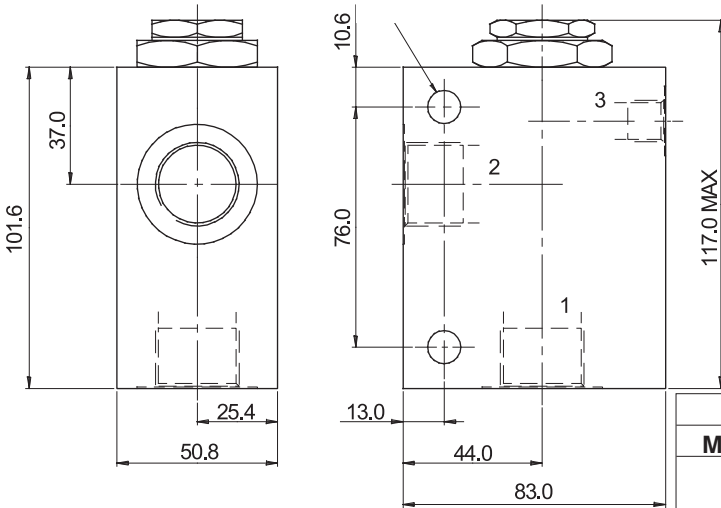

Body without valve			
Material	Ports	Port size	Type code
Aluminium	1, 2	G3/4	SB-S3-0107AL
	3	G1/4	
	1, 2	SAE 12, 1-1/16-12	SB-S3-0108AL
	3	SAE 6, 9/16-18	
Steel	1, 2	G3/4	SB-S3-0107ST
	3	G1/4	
	1, 2	SAE 12, 1-1/16-12	SB-S3-0108ST
	3	SAE 6, 9/16-18	

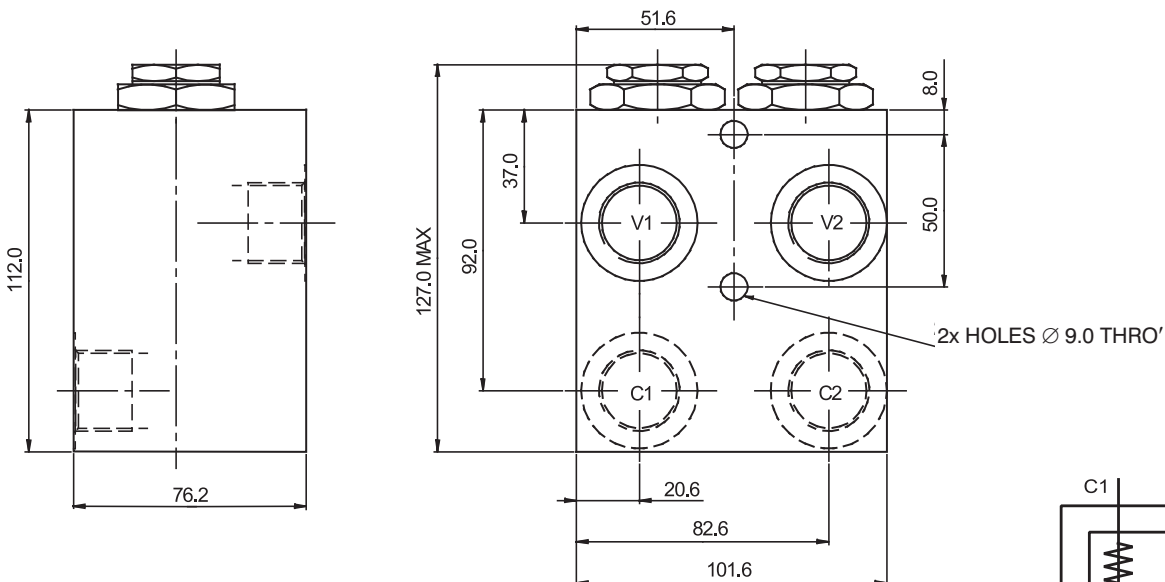

Dual body without valve			
Material	Ports	Port size	Type code
Aluminium	C1, C2, V1, V2	G3/4	SB-S4-0207AL
	C1, C2, V1, V2	SAE 12, 1-1/16-12	SB-S4-0208AL
Steel	C1, C2, V1, V2	G3/4	SB-S4-0207ST
	C1, C2, V1, V2	SAE 12, 1-1/16-12	SB-S4-0208ST

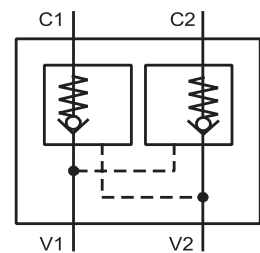

The use of aluminium bodies is limited to a maximum operating pressure of 210 bar.

Spare Parts

Seal kits on request.

Caution!

- The packing foil is recyclable.
- The technical information regarding the product presented in this catalogue is for descriptive purposes only. It should not be construed in any case as a guaranteed representation of the product properties in the sense of the law.

ARGO-HYTOS s.r.o. CZ - 543 15 Vrchlaví
 Tel.: +420-499-403111, Fax: +420-499-403421
 E-mail: sales.cz@argo-hytos.com
 www.argo-hytos.com

- Load-holding without leakage
- Low pressure drop
- Pilot seal
- Fits the same cavity as the Q3 overcentre valve

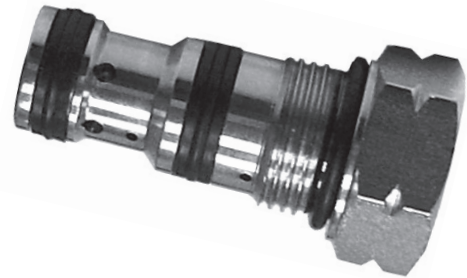
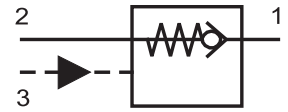

Functional Description

The one-way control valves make the flow possible in one direction with a low pressure drop and prevent from the flow in opposite direction.

The pressure in channel (1) causes a lifting of the valve ball from the seat against the spring. In this way it is released the flow from (1) into (2). The flow in the direction from (2) to (1) is not possible because the spring action and pressure in channel (2) result in pressure exerted to the valve ball in the seat.

The control pressure in channel (3) acts to the control gate valve pressing the valve ball in the appropriate valve seat. In this way the flow is shut off closely in both the directions.

Control pressure for shutting off the valve = $\frac{\text{Pressure of channel (1)}}{2}$

At computing the control pressure it is necessary to take into consideration that the pressure in channel (2) increases the necessary control pressure by the same value multiplied by an efficient differential area having a value of 1-1/2 at a ratio of control areas of 2:1.

As for basic surface treatment the external part of the valve are zinc coated.

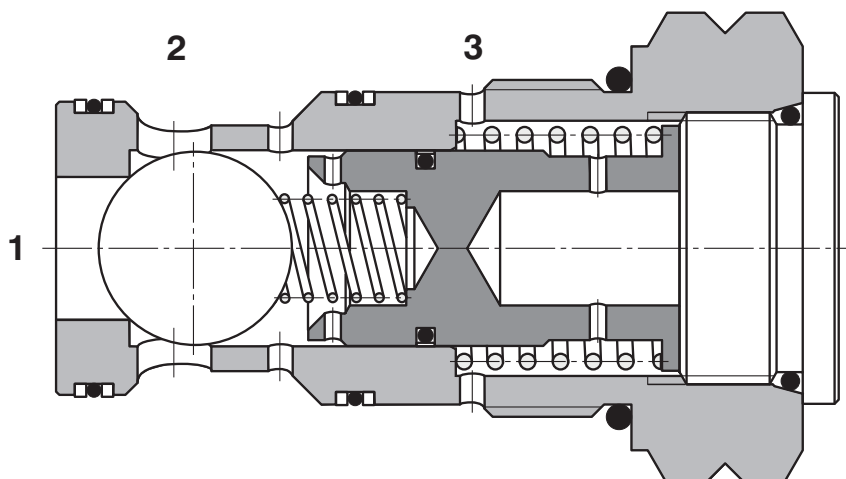

Ordering Code

SCC5H-Q3/I

Pilot Operated Check Valve
Pilot to close

no designation

Seals
NBR

Pilot ratio
Standard 2:1 **2**

Technical Data

Cavity		M20 x 1.5
Maximum flow	L/min	30
Max. pressure	bar	350
Pilot ratio		2:1
Pressure drops	bar	see $\Delta p - Q$ characteristics
Hydraulic fluid		Hydraulic oil (HM, HV) according to DIN 51524
Fluid temperature range	°C	-20 ... +90
Viscosity	mm ² /s	20 ... 400
Maximum degree of fluid contamination		According to ISO 4406, Class 21/18/15
Weight	kg	0.08
Maximum valve tightening torque in valve body or in control block	Nm	45 ⁺²
Mounting position		Unrestricted

Δp -Q Characteristics

Measured at $v = 40 \text{ mm}^2/\text{s}$

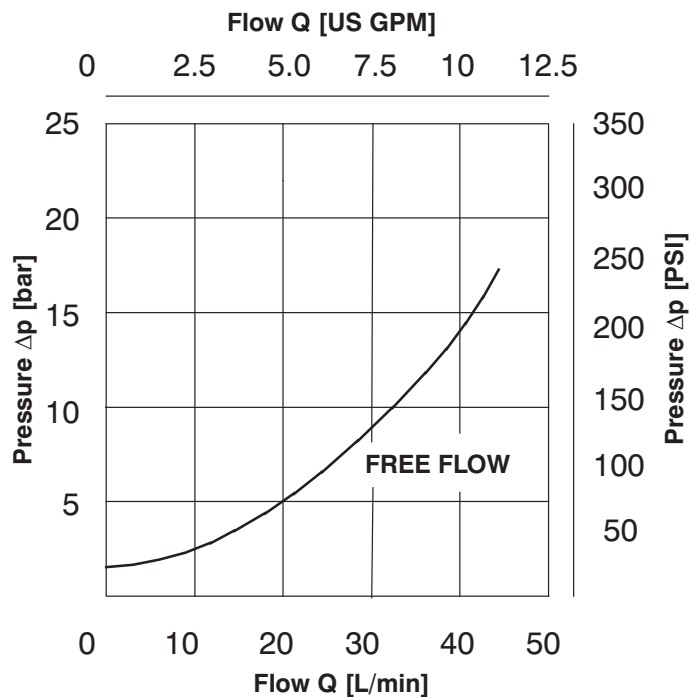

Dimensions

Measurements in millimeters

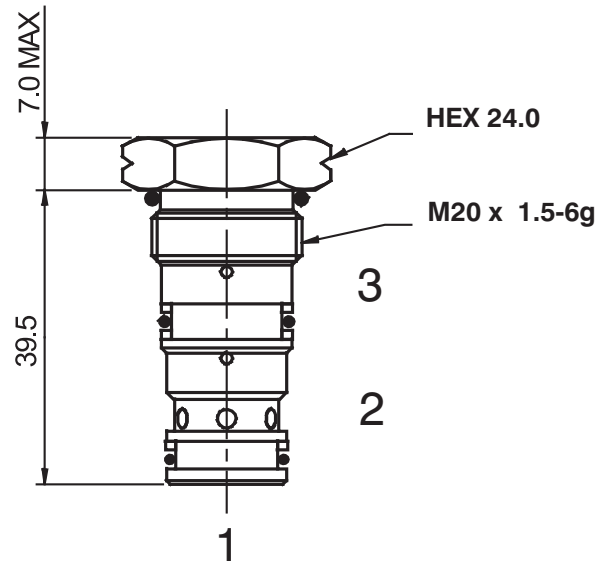

2

Cavity

Measurements in millimeters

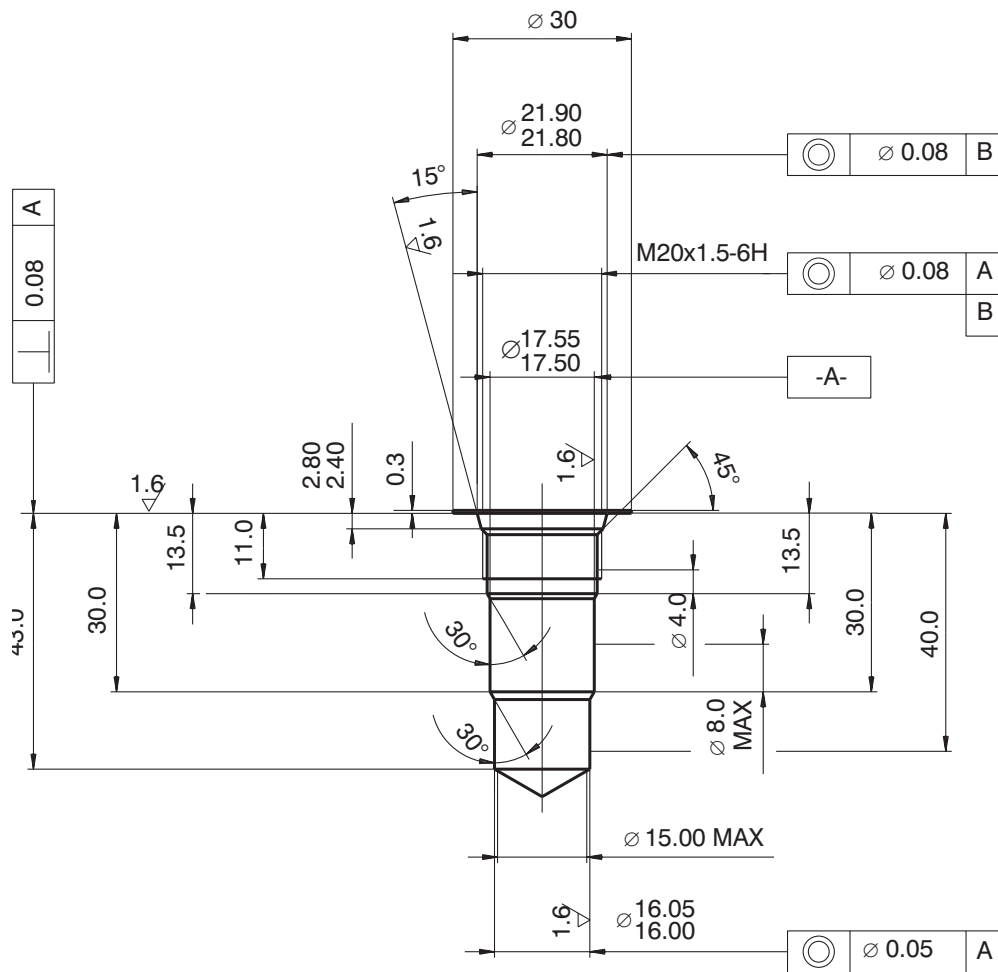

Valve Bodies

Measurements in millimeters

ISO A

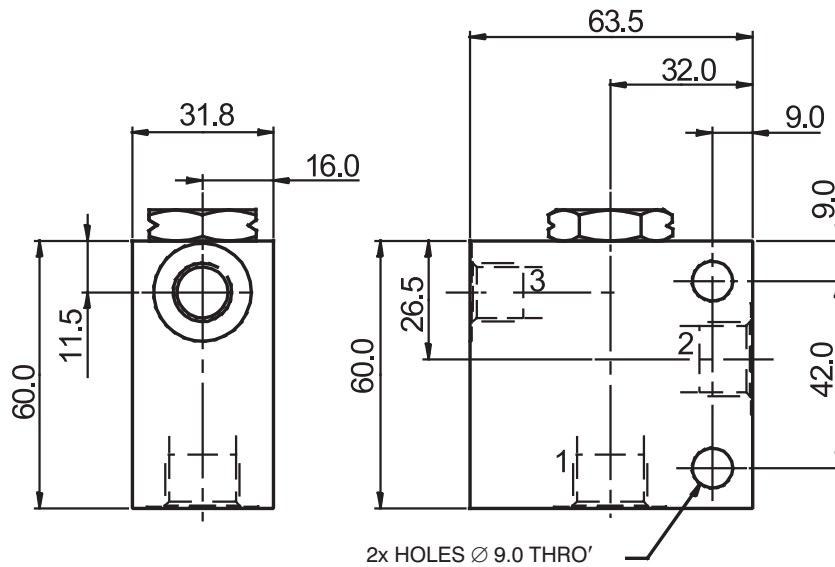
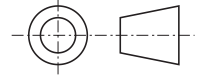

Body without valve			
Material	Ports	Port size	Type code
Aluminium	1, 2	G3/8	SB-Q3-0103AL
	3	G1/4	
	1, 2	SAE 8, 3/4-16	SB-Q3-0104AL
	3	SAE 6, 9/16-18	
Steel	1, 2	G3/8	SB-Q3-0103ST
	3	G1/4	
	1, 2	SAE 8, 3/4-16	SB-Q3-0104ST
	3	SAE 6, 9/16-18	

The use of aluminium bodies is limited to a maximum operating pressure of 210 bar.

Spare Parts

Seal kits on request.

Caution!

- The packing foil is recyclable.
- The technical information regarding the product presented in this catalogue is for descriptive purposes only. It should not be construed in any case as a guaranteed representation of the product properties in the sense of the law.

ARGO-HYTOS s.r.o. CZ - 543 15 Vrchlabí
 Tel.: +420-499-403 111
 E-mail: info.cz@argo-hytos.com
 www.argo-hytos.com

- Load-holding without leakage
- Low pressure drop
- Pilot seal
- Fits the same cavity as the S3 overcentre valve

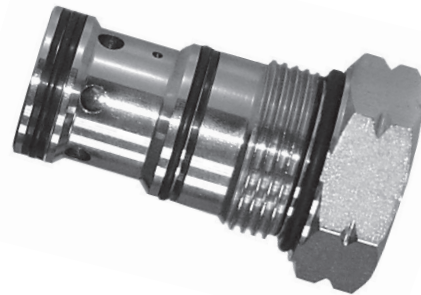
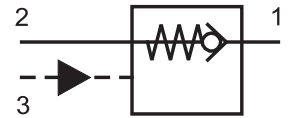

Functional Description

The one-way control valves make the flow possible in one direction with a low pressure drop and prevent from the flow in opposite direction.

The pressure in channel (1) causes a lifting of the valve ball from the seat against the spring. In this way it is released the flow from (1) into (2). The flow in the direction from (2) to (1) is not possible because the spring action and pressure in channel (2) result in pressure exerted to the valve ball in the seat.

The control pressure in channel (3) acts to the control gate valve pressing the valve ball in the appropriate valve seat. In this way the flow is shut off closely in both the directions.

Control pressure
for shutting off the valve = $\frac{\text{Pressure of channel (1)}}{2}$

At computing the control pressure it is necessary to take into consideration that the pressure in channel (2) increases the necessary control pressure by the same value multiplied by an efficient differential area having a value of 1-1/2 at a ratio of control areas of 2:1.

As for basic surface treatment the external part of the valve are zinc coated.

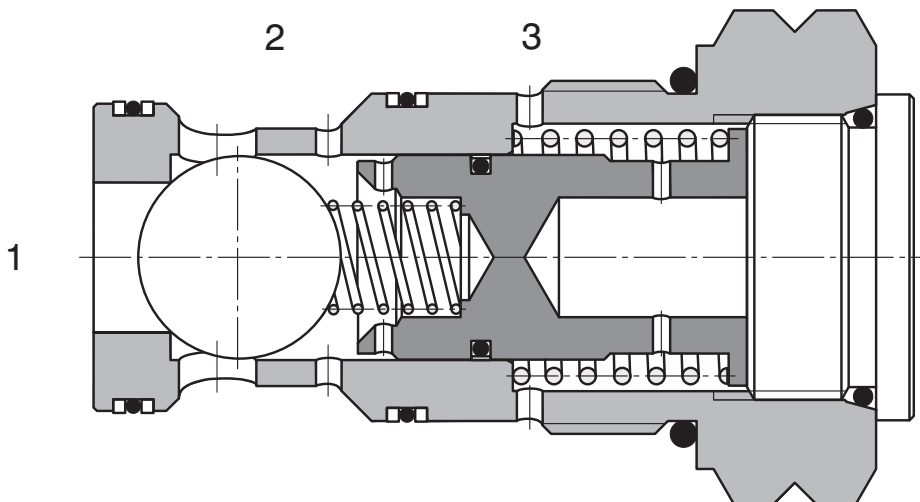

Ordering Code

SCC5H-S3/I

Pilot Operated Check Valve
Pilot to close

no designation

Seals
NBR

Pilot ratio
Standard 2:1 **2**

Technical Data

Cavity		1-5/16-12 UN-2A
Maximum flow	L/min	120
Max. pressure	bar	350
Pilot ratio		2:1
Pressure drops	bar	see $\Delta p - Q$ characteristics
Hydraulic fluid		Hydraulic oil (HM, HV) according to DIN 51524
Fluid temperature range	°C	-20 ... +90
Viscosity	mm ² /s	20 ... 400
Maximum degree of fluid contamination		According to ISO 4406, Class 21/18/15
Weight	kg	0.28
Maximum valve tightening torque in valve body or in control block	Nm	100 ⁺²
Mounting position		unrestricted

Δp -Q Characteristics

Measured at $v = 40 \text{ mm}^2/\text{s}$

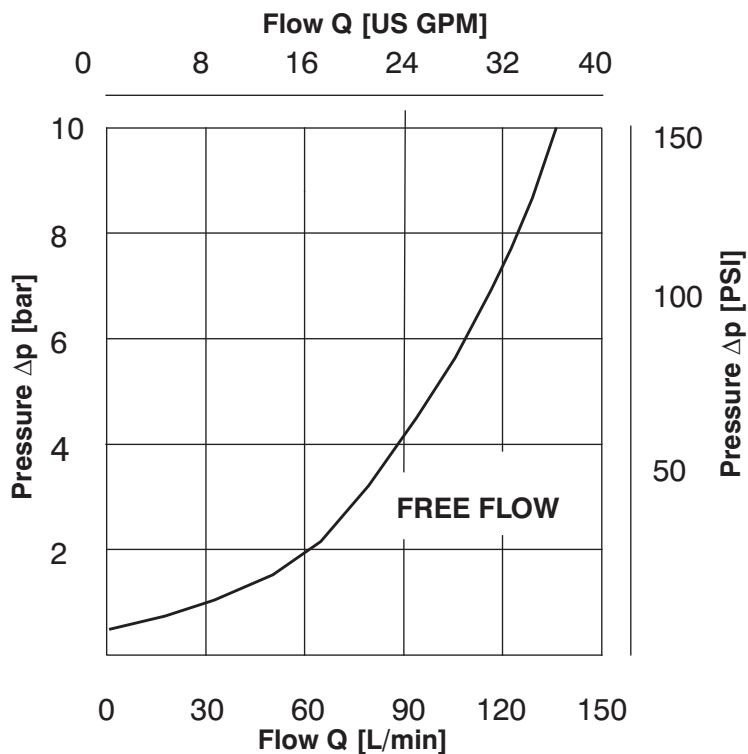

Dimensions

Measurements in millimeters

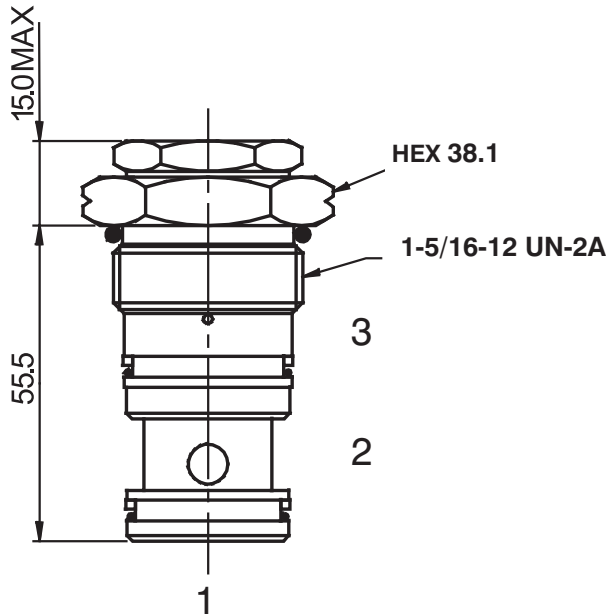

2

Cavity

Measurements in millimeters

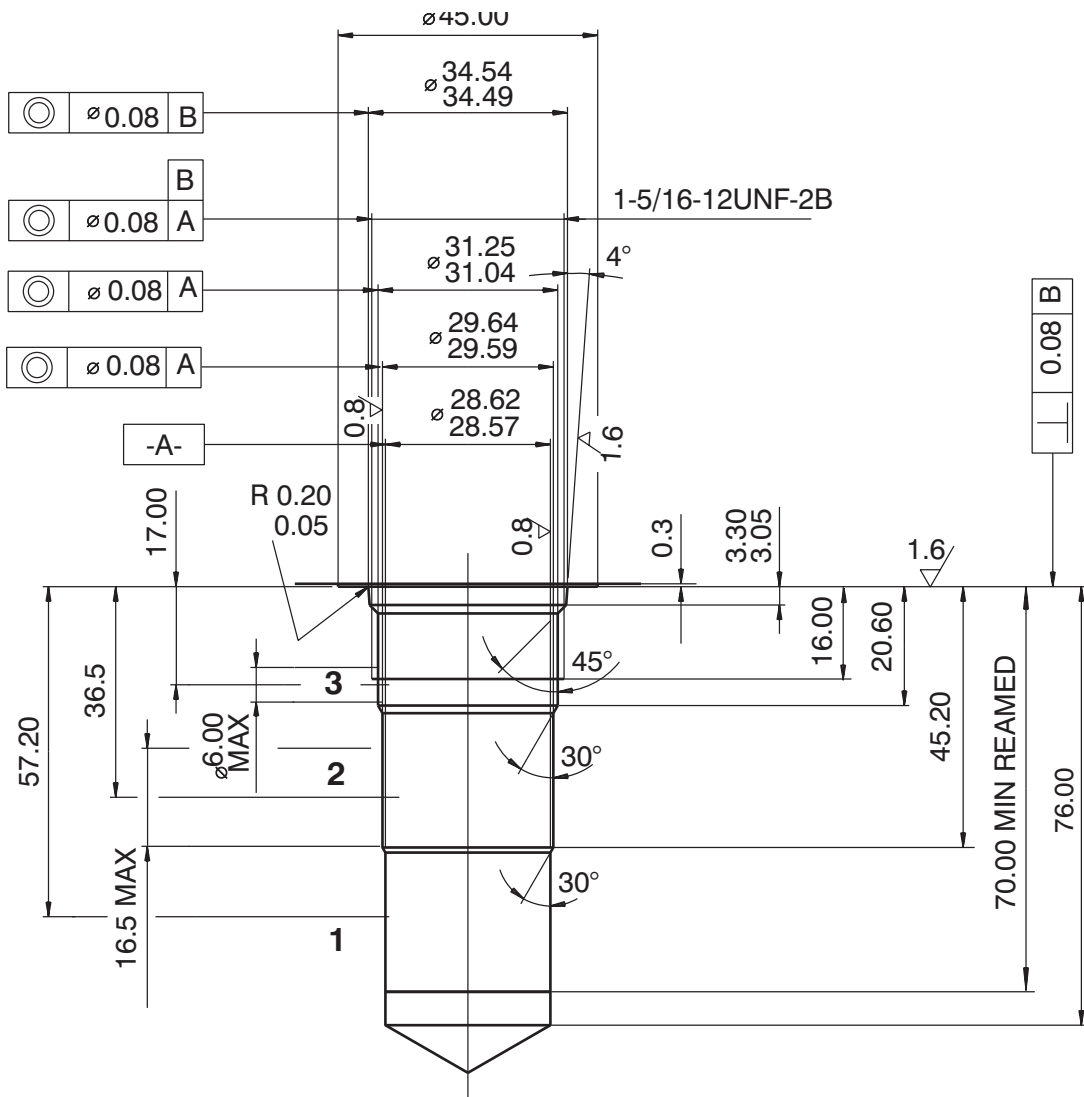

Valve Bodies

Measurements in millimeters

ISO A

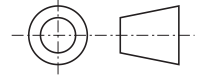

2

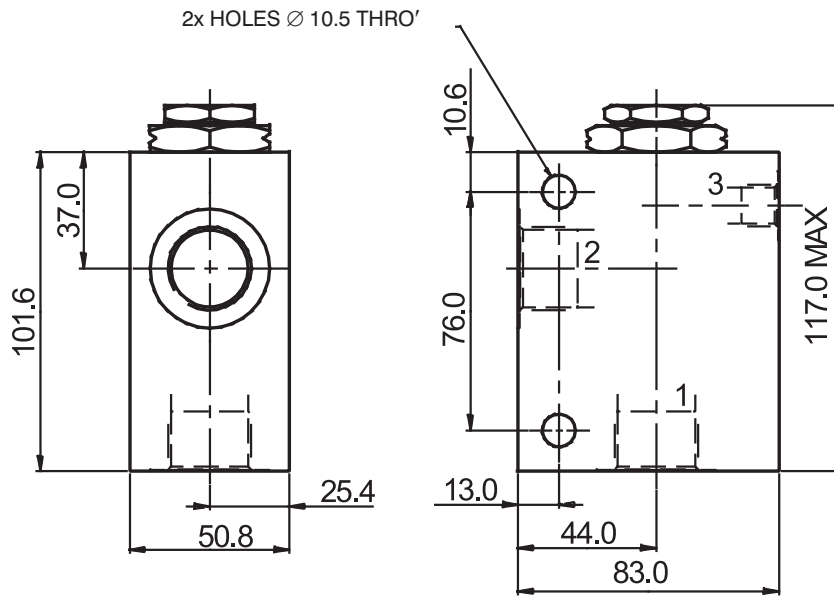

Body without valve			
Material	Ports	Port size	Type code
Aluminium	1, 2	G3/4	SB-S3-0107AL
	3	G1/4	
	1, 2	SAE 12, 1-1/16-12	SB-S3-0108AL
	3	SAE 6, 9/16-18	
Steel	1, 2	G3/4	SB-S3-0107ST
	3	G1/4	
	1, 2	SAE 12, 1-1/16-12	SB-S3-0108ST
	3	SAE 6, 9/16-18	

The use of aluminium bodies is limited to a maximum operating pressure of 210 bar.

Spare Parts

Seal kits on request.

Caution!

- The packing foil is recyclable.
- The technical information regarding the product presented in this catalogue is for descriptive purposes only. It should not be construed in any case as a guaranteed representation of the product properties in the sense of the law.

ARGO-HYTOS s.r.o. CZ - 543 15 Vrchlabí
 Tel.: +420-499-403111, Fax: +420-499-403421
 E-mail: sales.cz@argo-hytos.com
 www.argo-hytos.com

Pressure Valves

3

Pressure Valves

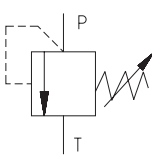
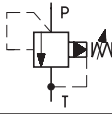
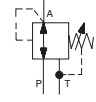
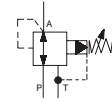
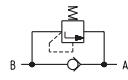
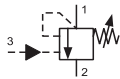
Symbol example	Flow l/min (GPM)	Pressure bar (PSI)	Type Code	Cartridge	NFPA D02, CETOP 2; NG4	NFPA D03, CETOP 3; NG6	NFPA D05, CETOP 5, NG10	Line Mounted	Page	Data Sheet
Directly Operated Pressure Relief Valves										
	30 (8)	350 (5100)	SR1A-A2	X	(X)			(X)	3.05	HA 5063
	40 (11)	320 (4600)	VPP2-04	X	(X)			(X)	3.01	HA 5093
	50 (13)	320 (4600)	VPP1-06	X				(X)	3.04	HA 5061
	50 (13)	320 (4600)	VPP2-06	X		(X)		(X)	3.02	HA 5062
	50 (13)	320 (4600)	VPP2-06-SV	X		(X)		(X)	3.03	HA 5066
	60 (16)	420 (6100)	SR1A-B2	X		(X)		(X)	3.06	HA 5064
	120 (32)	320 (4600)	VPP1-08					(X)	3.04	HA 5061
	120 (32)	320 (4600)	VPP1-10	X		(X)		(X)	3.04	HA 5061
Pilot Operated Pressure Relief Valves										
	70 (18)	320 (4600)	VPN1-06	X		(X)		(X)	3.08	HA 5161
	100 (26)	350 (5100)	SR4A-B2	X		(X)		(X)	3.07	HA 5065
	150 (40)	350 (5100)	VPN2-10/S	X			(X)	(X)	3.09	HA 5163
	150 (40)	350 (5100)	VPN2-10/MR				X		3.10	HA 5164
Directly Operated Pressure Reducing Valves										
	20 (5)	350 (5100)	SP2A-A3	X	(X)			(X)	3.11	HA 5143
	60 (16)	420 (6100)	SP2A-B3	X		(X)		(X)	3.12	HA 5146
	20 (5)	320 (4600)	VRP2-04		X				3.13	HA 5142
	50 (13)	350 (5100)	VRP2-06			X			3.14	HA 5145
Pilot Operated Pressure Reducing Valves										
	40 (11)	320 (4600)	VRN2-06	X		(X)			3.15	HA 5153
	60 (16)	350 (5100)	SP4A-B3	X		(X)		(X)	3.17	HA 5144
	150 (40)	320 (4600)	VRN2-10	X			(X)		3.16	HA 5154
Combined Relief-Check Valves										
	200 (53)	420 (6100)	DBV2-420	X					3.18	HA 5092
Pilot Operated Priority Unloading Valves										
	60 (16)	350 (5100)	SU6A-U3/I	X				(X)	3.19	HA 5224
	60 (16)	350 (5100)	SUD6A-U4/I	X				(X)	3.21	HA 5226
	200 (53)	350 (5100)	SUD6A-V4/I	X				(X)	3.20	HA 5225

- Screw-in cartridge, modular and in-line design
- Six pressure ranges
- Two pressure adjustment options
- Subplates see data sheet HA 0002

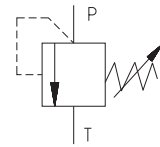

3

Functional Description

Pressure relief valves VPP2-04 were designed for applications requiring a safety valve or a pressure regulating valve working over a wide range of pressures and flow rates.

The valve basically consists of the valve body (1), poppet with damping spool (2) and compression spring (3). The spring pushes the poppet onto the seat (5) holding the valve in its normally closed position. When the force, caused by the pressure acting on the exposed surface area of the poppet, exceeds the spring force, the valve

opens and the flow passes from port P to port T.

To optimize the valve performance, six pressure ranges are available. Choosing the closest range is recommended. The design enables the valve to be used as a screw-in cartridge for manifold mounting, or in a subplate and/or in-line mounted housing.

The valve body and the adjustment screw are zinc coated. With models M and R the valve bodies are phosphate coated.

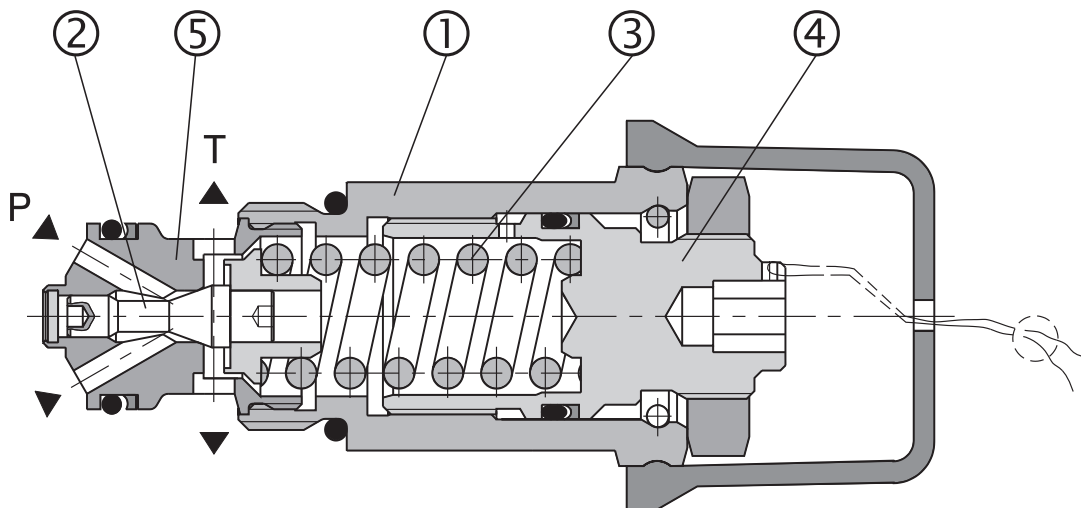

Ordering Code

Directly Operated Pressure Relief Valve

Model

- screw in cartridge
- modular valve, connection A - T
- modular valve, connection B - T
- modular valve, connection P - T
- modular valve, connection A - B and B - A
- modular valve, connection A - T and B - T
- modular valve, connection A - T
- modular valve, connection B - T
- modular valve, connection P - T
- modular valve, connection A - B and B - A
- modular valve, connection A - T and B - T
- in-line valve, thread G3/8 - P1, P2, T
- in-line valve, thread G1/2 - P1, P2, T
- in-line valve, thread G3/8 - P, T
- in-line valve, thread G1/2 - P, T

- S**
- MA04
- MB04
- MP04**
- MC04
- MD04
- MA06
- MB06
- MP06**
- MC06
- MD06
- RA1
- RA2**
- RB1
- RB2

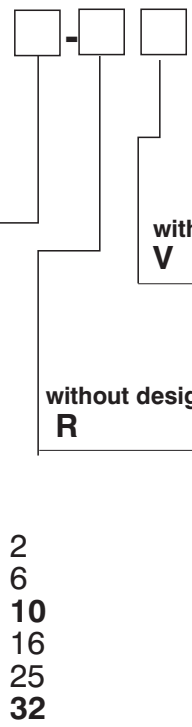

- Pressure range**
- 2 up to 25 bar
- 6 up to 63 bar
- 10** up to 100 bar
- 16 up to 160 bar
- 25 up to 250 bar
- 32 up to 320 bar

FOR PREFERRED TYPES SEE BOLD TYPING IN ORDERING CODE AND TABLE OF PREFERRED TYPES ON PAGE 11

Functional Symbols

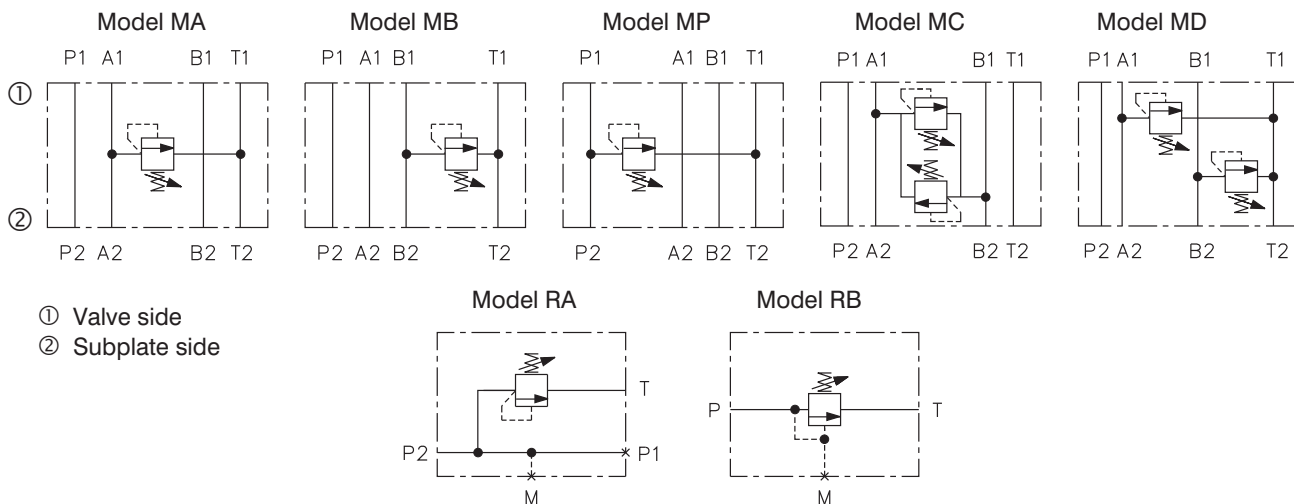

Ordering Numbers of Sandwich / Valve Bodies (without screw-in cartridge)

Valve body for modular valve - NBR	Ordering number	Valve body for modular valve - Viton	Ordering number
MA04-VP	15907500	MA04-VP/V	22501800
MB04-VP	15907600	MB04-VP/V	22501900
MP04-VP	15907700	MP04-VP/V	22502000
MC04-VP	15907800	MC04-VP/V	22502100
MD04-VP	15907900	MD04-VP/V	22502200
Valve body for modular valve - NBR	Ordering number	Valve body for modular valve - Viton	Ordering number
MA06-VP	15988600	MA06-VP/V	22949600
MB06-VP	15988800	MB06-VP/V	16661700
MP06-VP	15989000	MP06-VP/V	22949800
MC06-VP	15989200	MC06-VP/V	16758800
MD06-VP	15989300	MD06-VP/V	22950100

Ordering Numbers of Sandwich / Valve Bodies (without screw-in cartridge)

Valve body for in-line valve - NBR	Ordering number	Valve body for in-line valve - Viton	Ordering number
RA1-06-VP	15989400	RA1-06-VP/V	22950200
RA2-06-VP	15989500	RA2-06-VP/V	22950300
RB1-06-VP	15989600	RB1-06-VP/V	22950400
RB2-06-VP	15989700	RB2-06-VP/V	22950500

Technical Data for Model S

Nominal size	mm	04
Max. flow rate	L/min	40
Max. service pressure ports (P, T, A, B)	bar	350
Working pressure related to flow	bar	see p-Q characteristics
Hydraulic fluid		Hydraulic oils of power classes (HL, HLP) to DIN 51 524
Fluid temperature range for standard sealing (NBR)	°C	-30 ... +100
Fluid temperature range for Viton sealing (FPM)	°C	-20 ... +120
Viscosity range	mm ² /s	20 ... 400
Max. degree of fluid contamination		Class 21/18/15 according to ISO 4406
Weight - model S	kg	0,17
Weight - models MA04, MB04, MP04		0.82
- models MC04, MD04		1.32
- models MA06, MB06, MP06	kg	1.12
- models MC06, MD06		1.42
- models RA1, RA2, RB1, RB2		1.17
Mounting position		unrestricted

p-Q Characteristics for Model S

Measured at $\nu = 32 \text{ mm}^2/\text{s}$

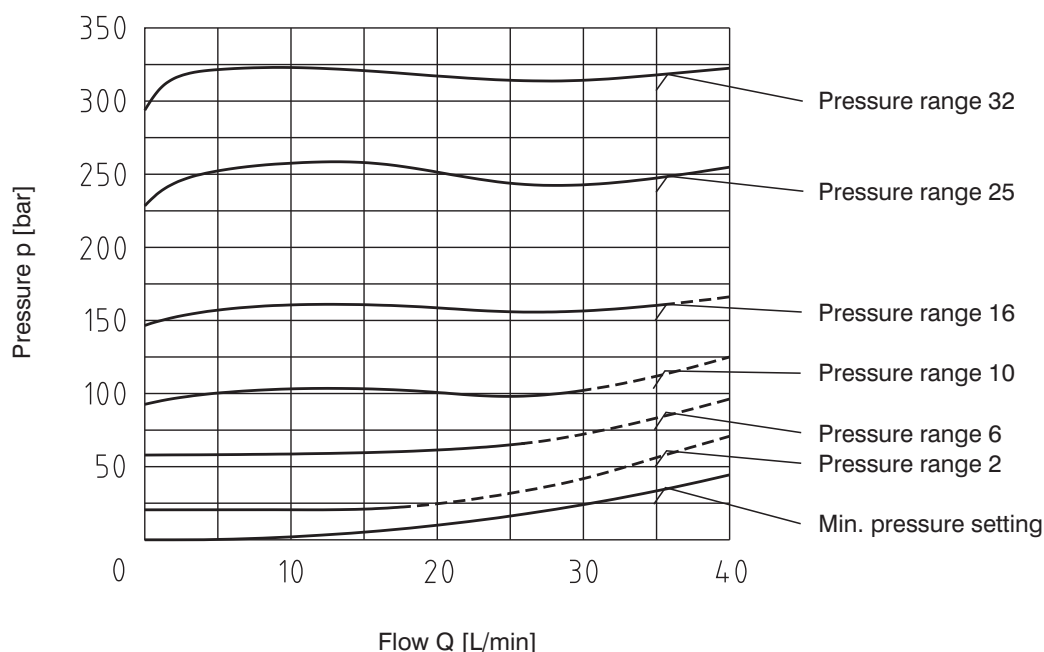

Δp-Q Characteristics (min. pressure setting)

Measured at $v = 32 \text{ mm}^2/\text{s}$

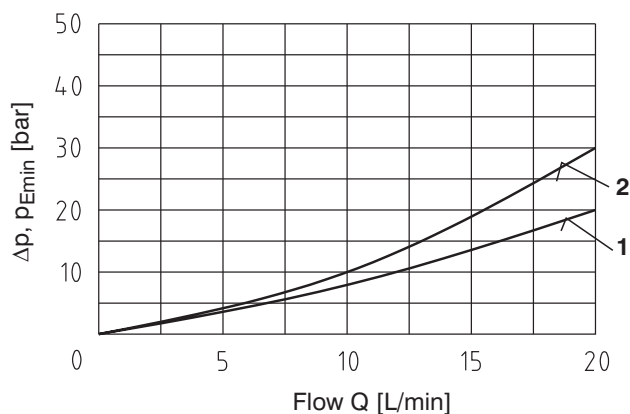

1 - MA04, MB04, MP04, MD04
2 - MC04

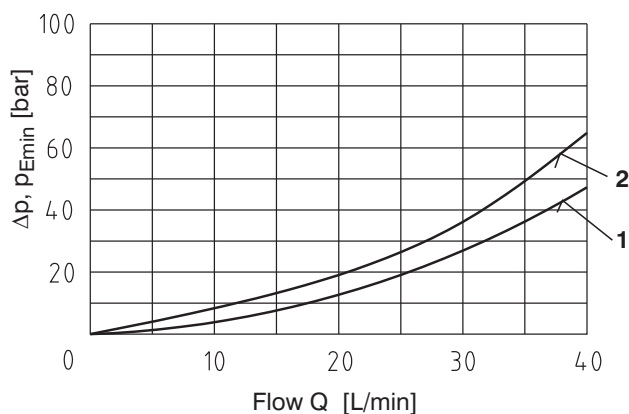

1 - MA06, MB06, MP06, MD06
2 - MC06

Valve Dimensions

Dimensions in millimeters

Model S

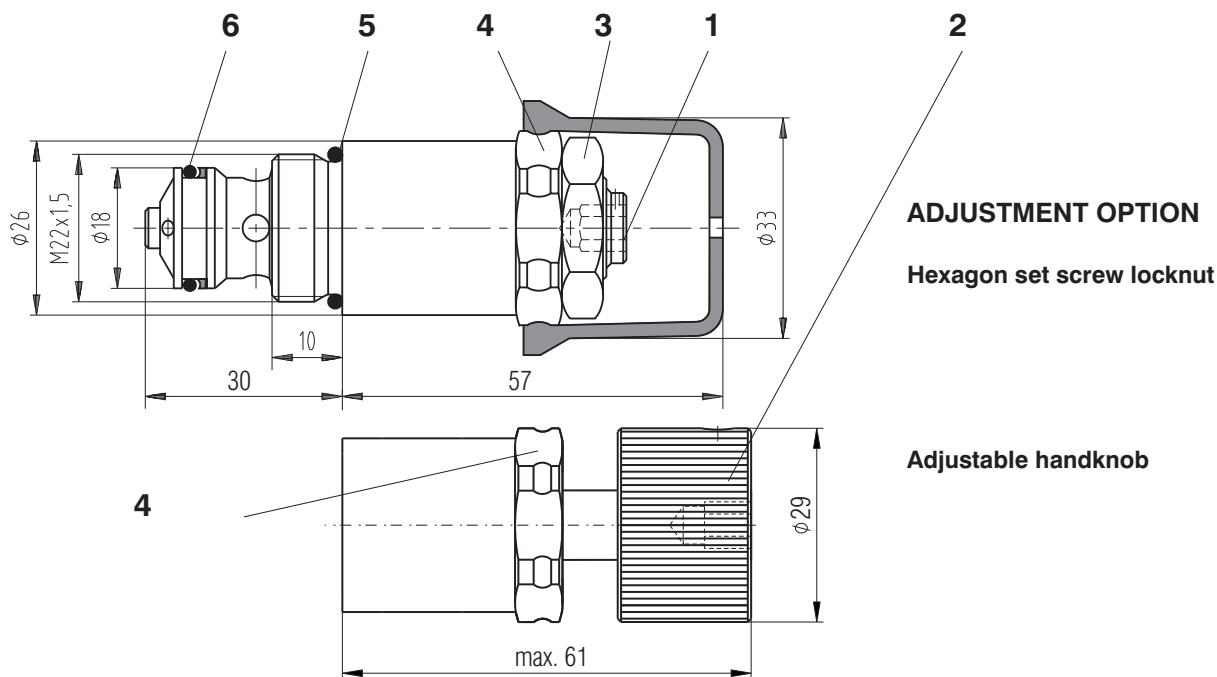

Cavity

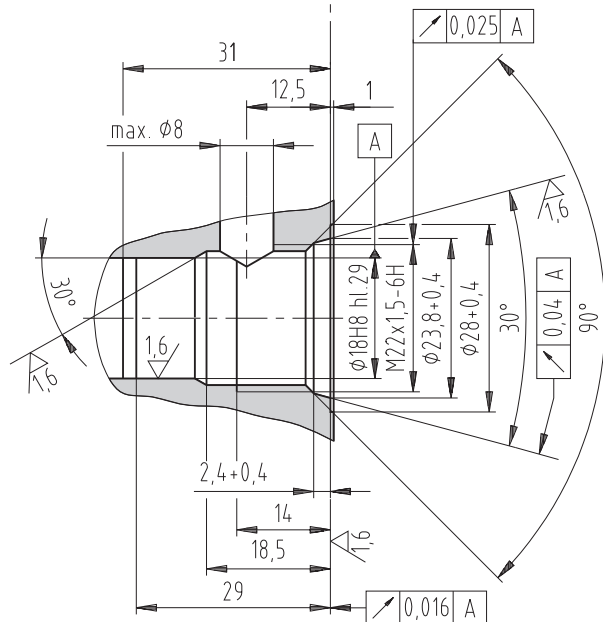

Dimensions in millimeters:

- 1 Adjustment element (screw with internal HEX 6)
- clockwise rotation - pressure increase
- anticlockwise rotation - pressure decrease
- 2 Adjustable handknob model "R"
- 3 Locknut HEX 24
- 4 Wrench flats HEX 27
- tightening torque 30 Nm
- 5 O-ring 19.4 x 2.1 (1 pc.)
supplied with valve
- 6 Combined seal:
O-ring 14 x 1.78 (1 pc.)
Back-up ring BBP80B015-N9
14,73 x 17,43 x 1,14 (1 pc.)
supplied with valve

Valve Dimensions

Dimensions in millimeters

Size 04 (Installation dimensions to ISO 4401, CETOP- RP 121H)

Model MA

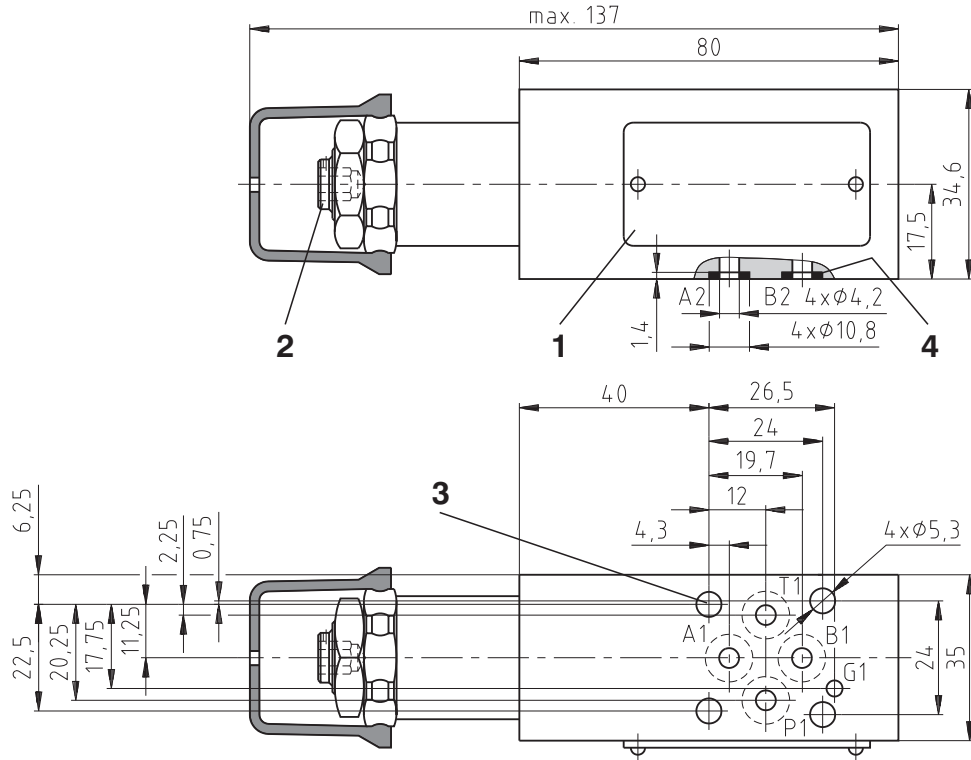

- 1 Name plate
- 2 Adjustment element (screw with internal HEX 6)
- 3 4 through mounting holes
- 4 Square rings 7.65 x 1.68 (4 pcs.)
supplied with valve

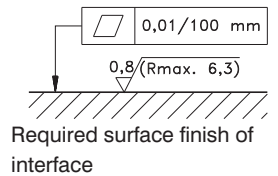

Models MB, MP

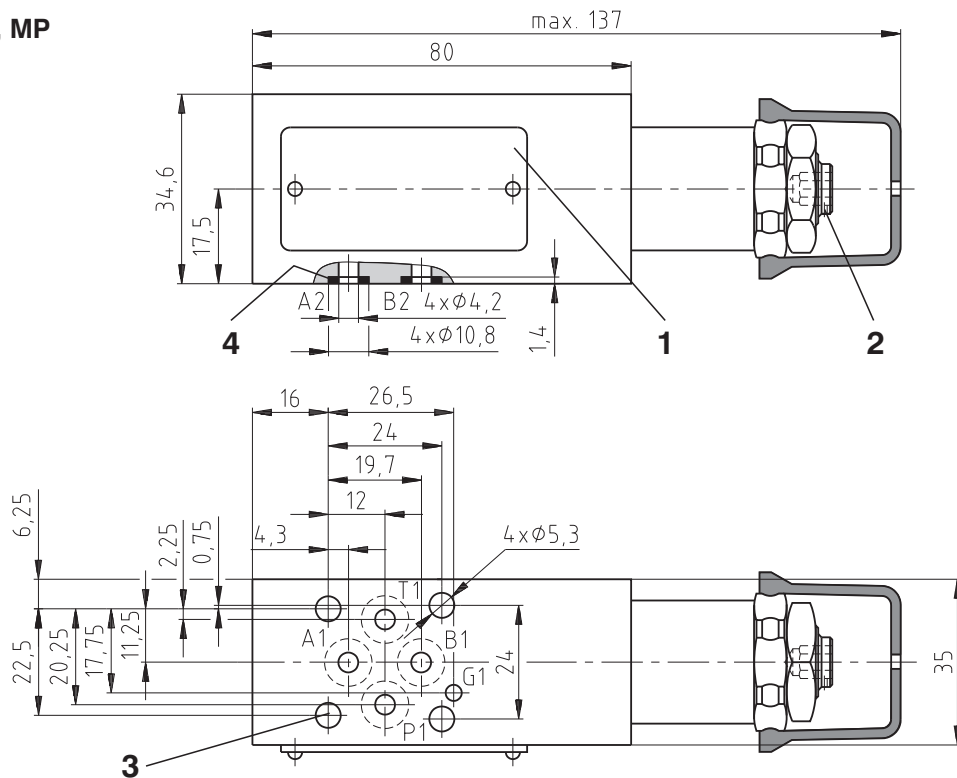

Valve Dimensions

Dimensions in millimeters

Models MC, MD

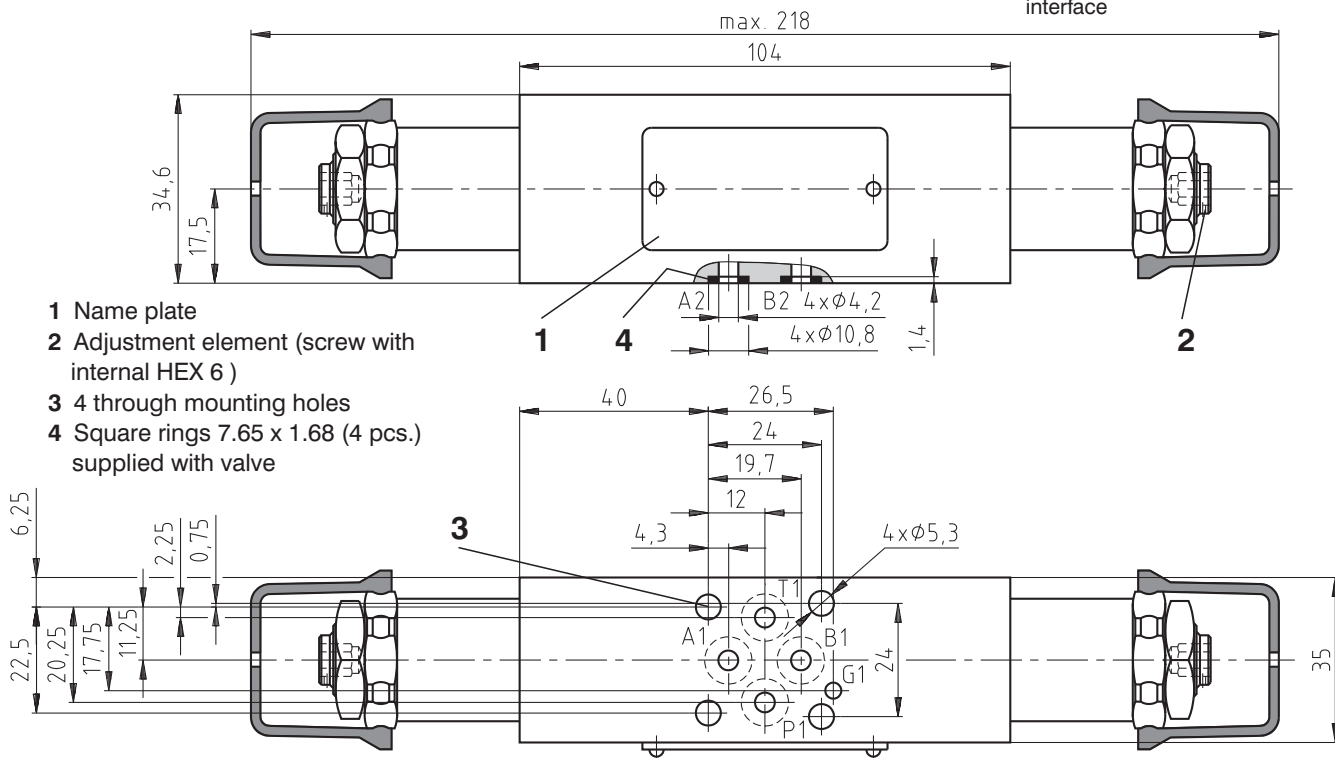
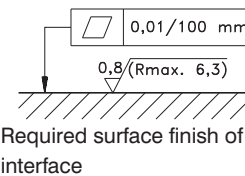

- 1 Name plate
- 2 Adjustment element (screw with internal HEX 6)
- 3 4 through mounting holes
- 4 Square rings 7.65 x 1.68 (4 pcs.) supplied with valve

Valve Dimensions

Dimensions in millimeters

Size 06 (Installation dimensions to ISO 4401, DIN 24 340)

Model MA

- 1 Name plate
- 2 Adjustment element (screw with internal HEX 6)
- 3 4 through mounting holes
- 4 Square rings 9.25 x 1.68 (4 pcs.) supplied with valve

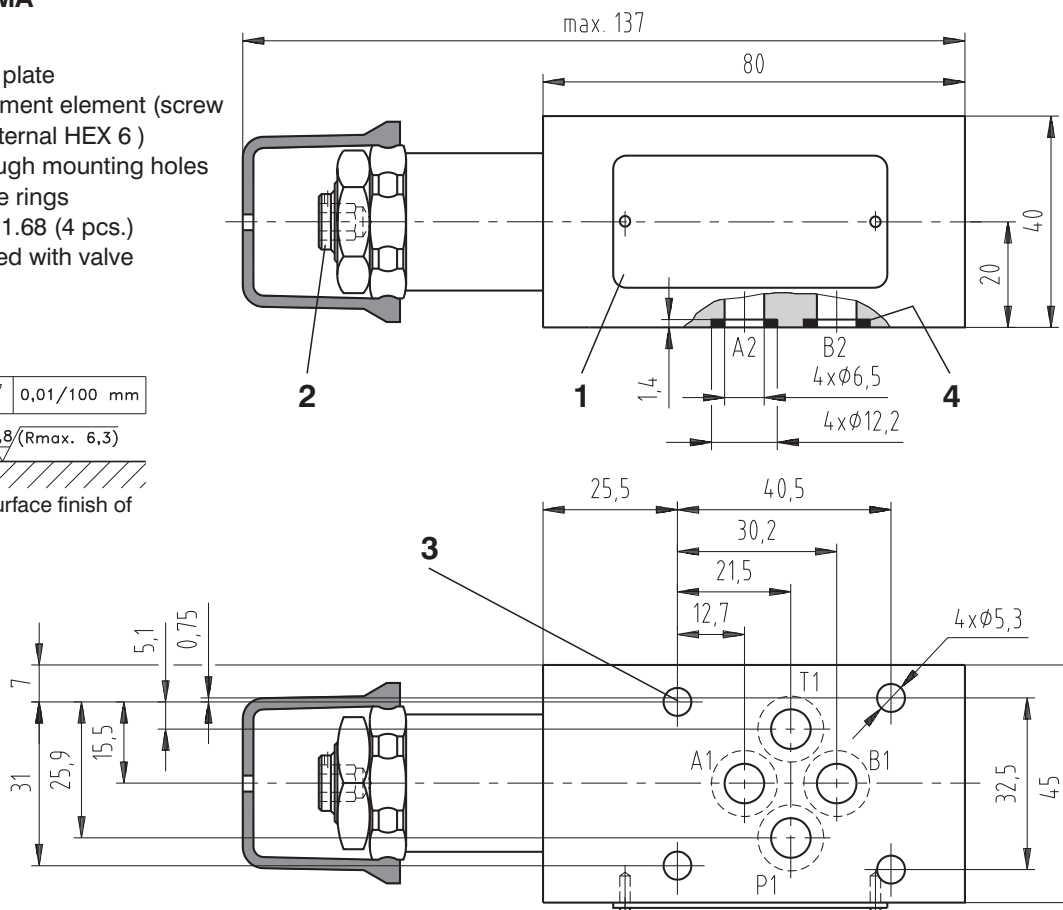
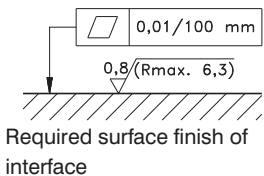

Valve Dimensions

Dimensions in millimeters

Models MB, MP

- 1 Name plate
- 2 Adjustment element (screw with internal HEX 6)
- 3 4 through mounting holes
- 4 Square rings 9.25 x 1.68 (4 pcs.) supplied with valve

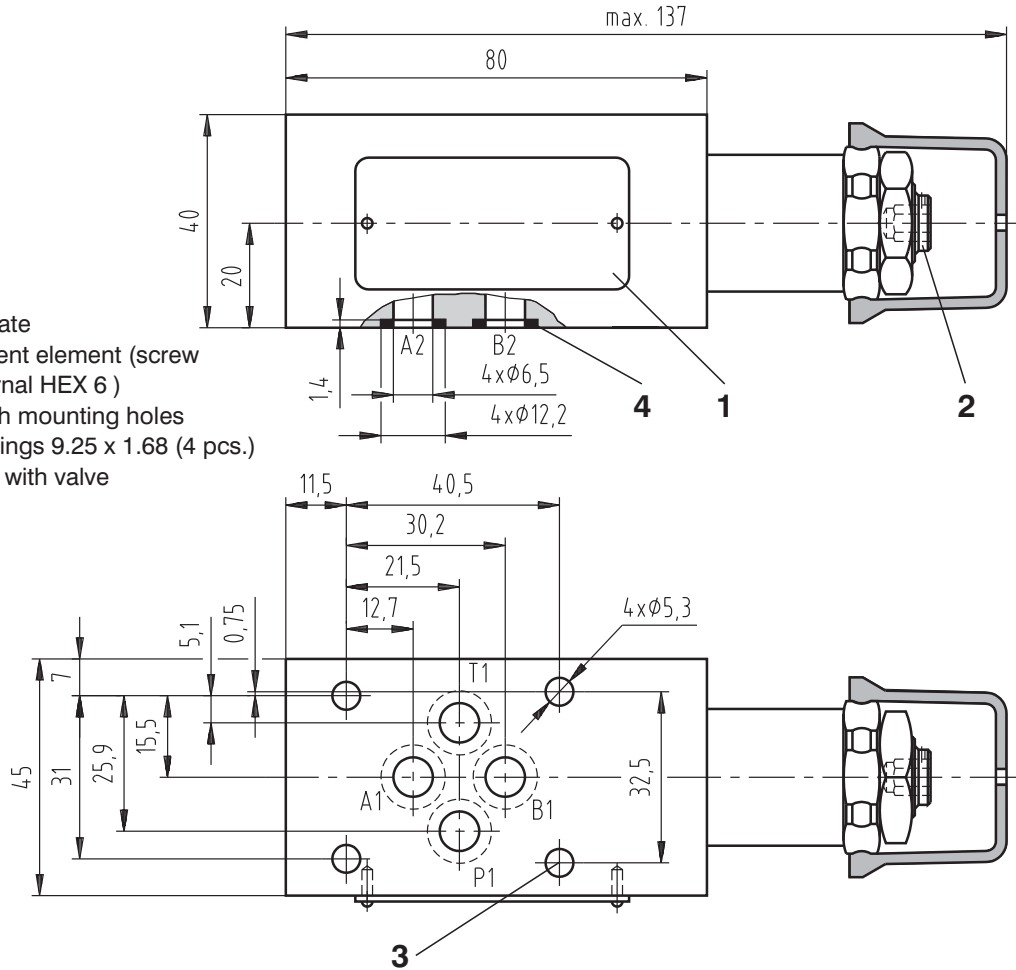

Models MC, MD

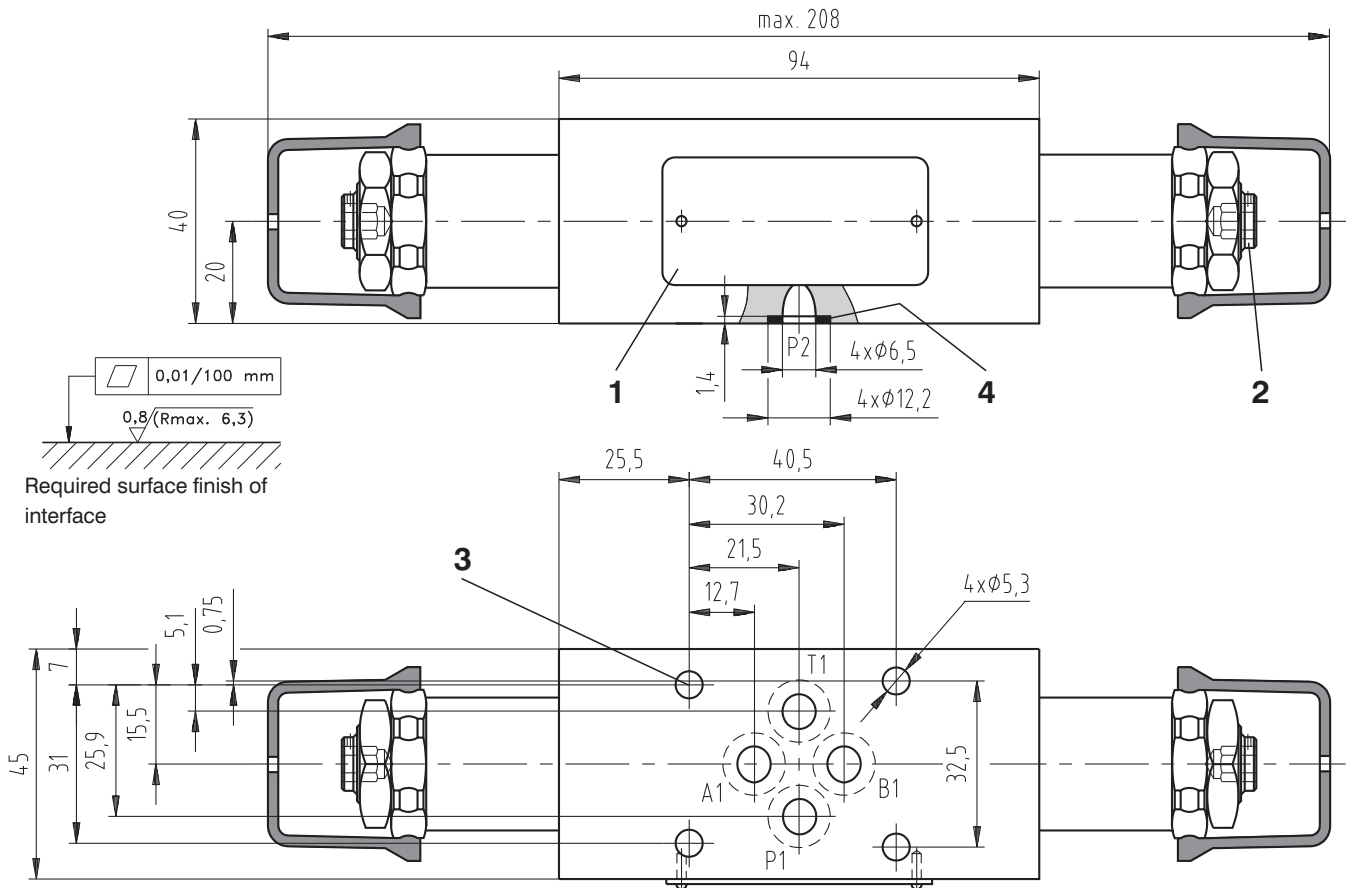

0,01/100 mm
 0,8 (Rmax. 6,3)
 Required surface finish of interface

3

Valve Dimensions

Dimensions in millimeters

Model RA1

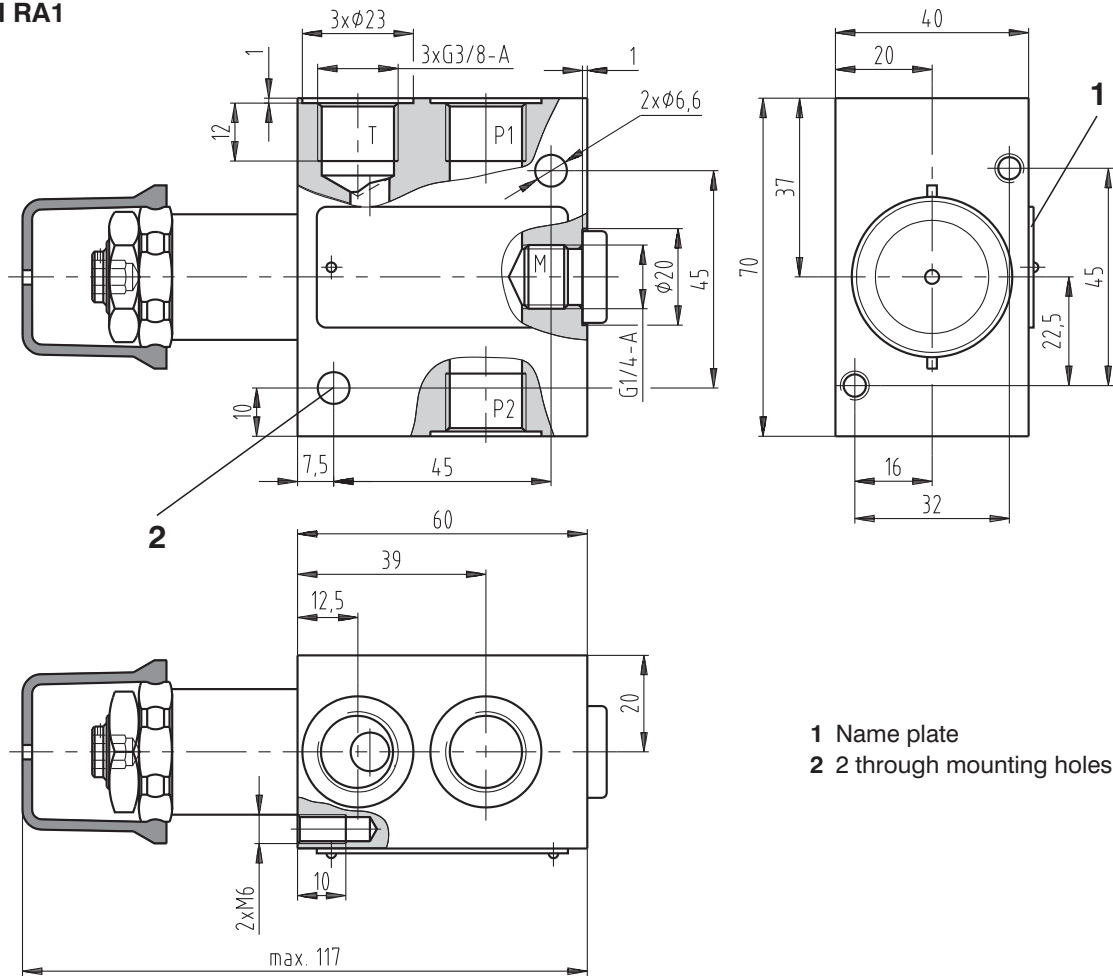

Model RA2

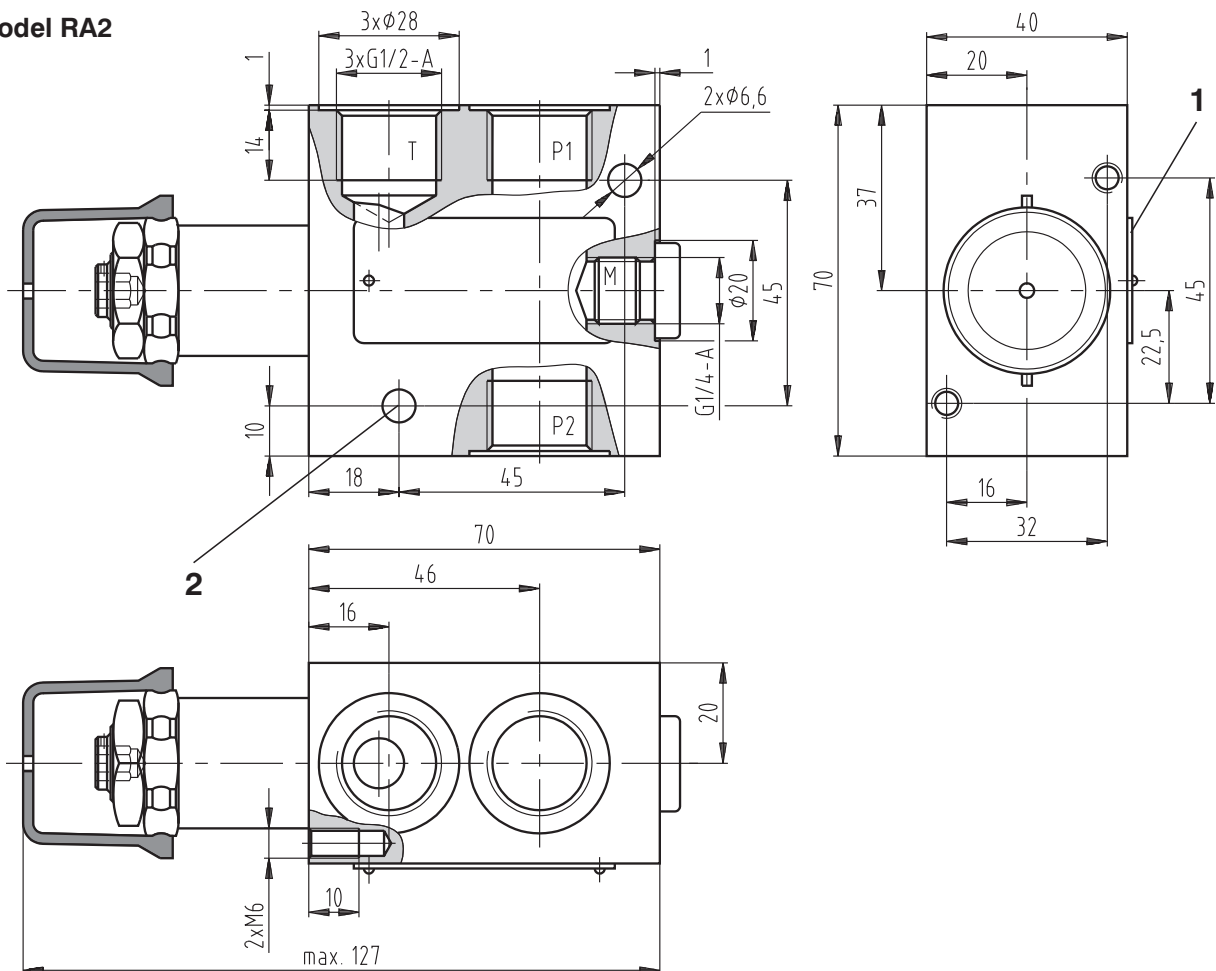

Valve Dimensions

Dimensions in millimeters

Model RB1

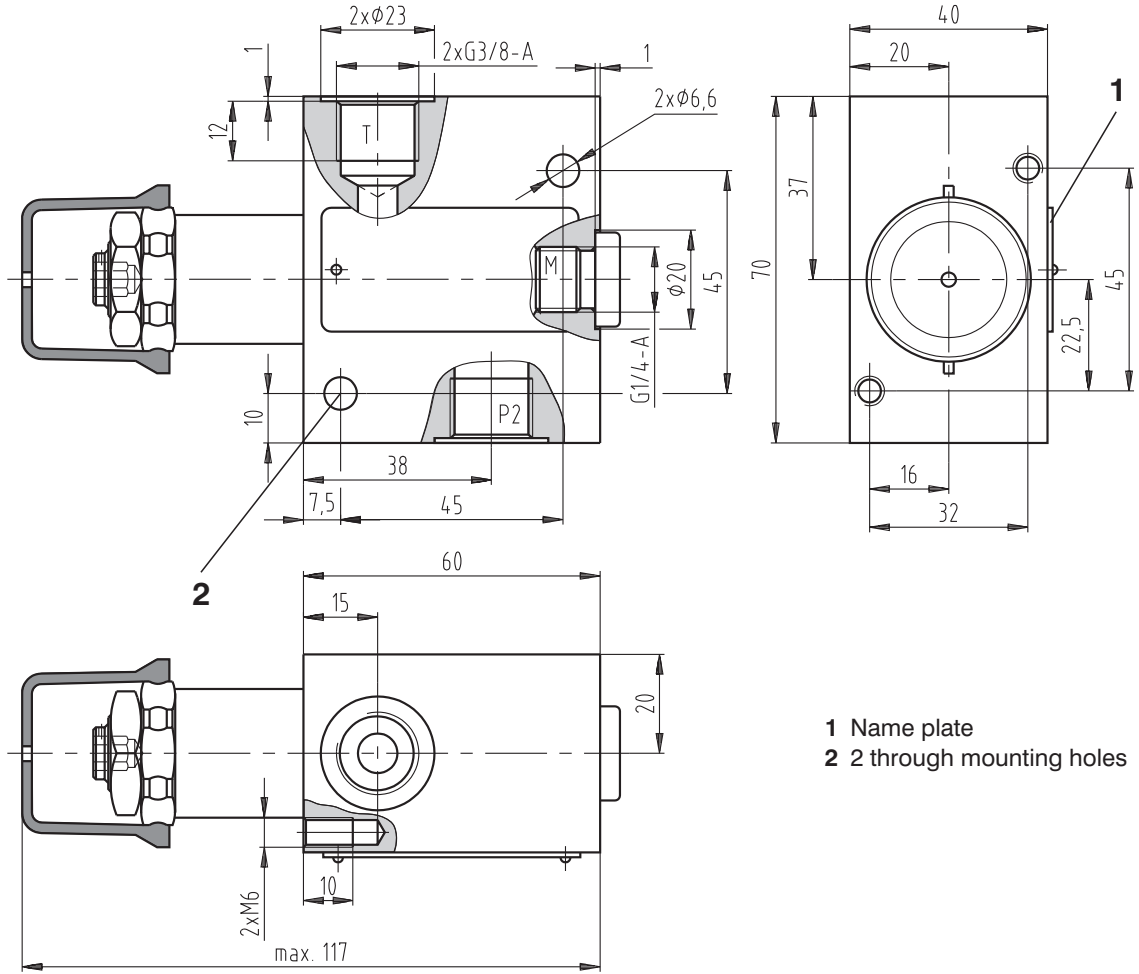

Model RB2

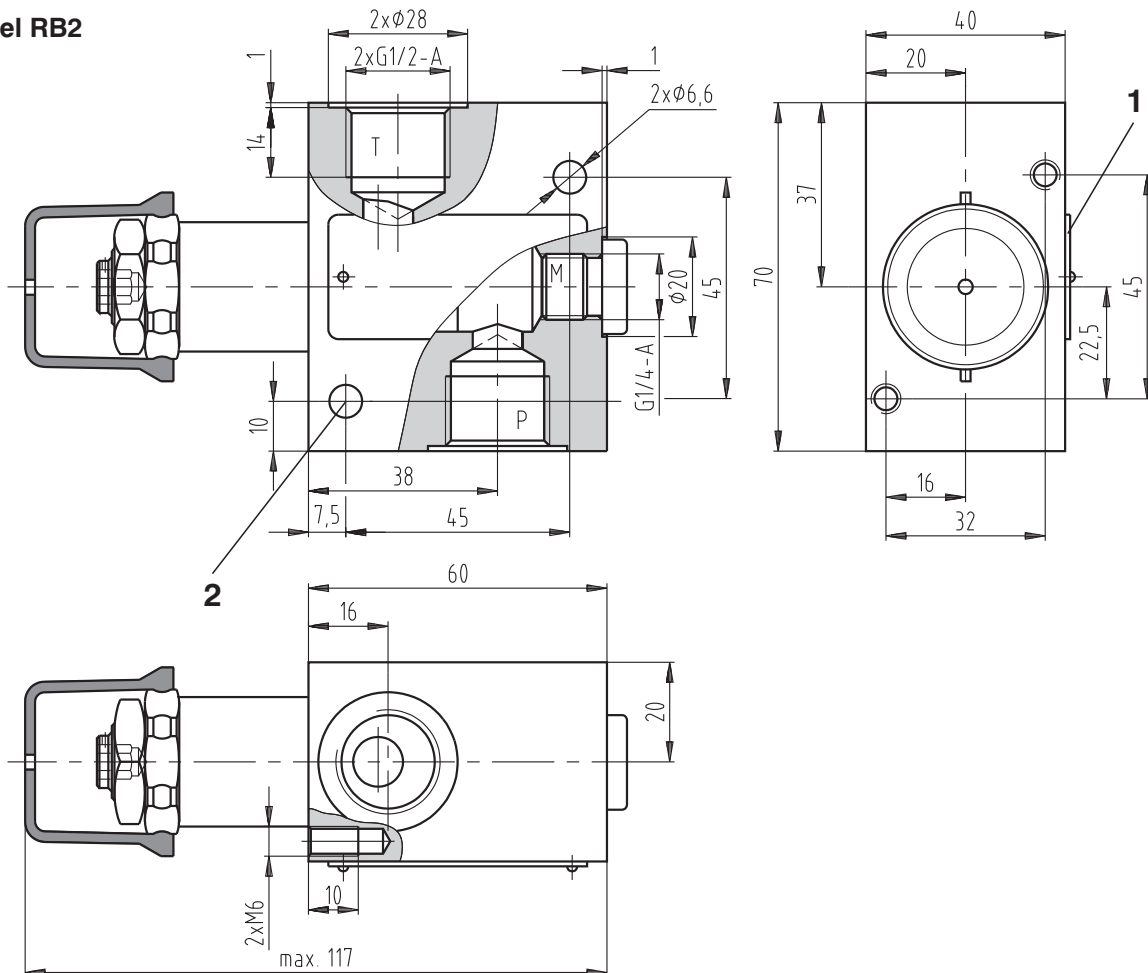

Spare Parts

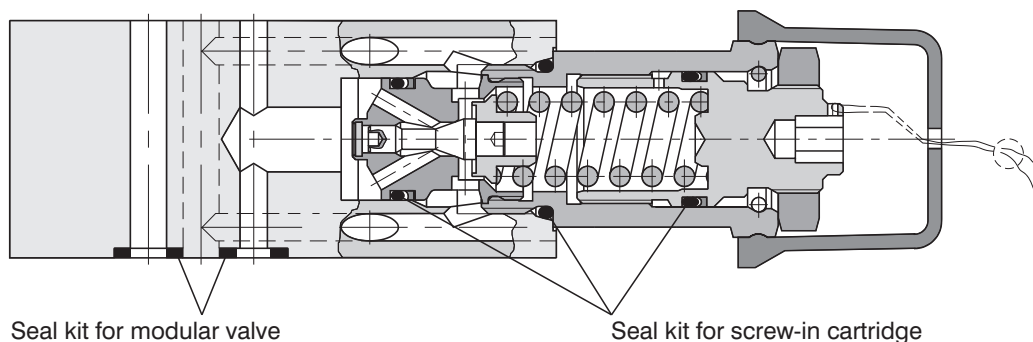

3

Model	Dimensions, quantity	Ordering number
Screw-in cartridge - NBR	O-ring 14 x 1.78 NBR 90 (1 pc.)	15908000
	O-ring 17 x 1.8 NBR 70 (1 pc.)	
	O-ring 19.4 x 2.1 NBR 80 (1 pc.)	
	Back-up ring BBP80B015-N9 14.73 x 17.43 x 1.14 (1 pc.)	
	Back-up ring BBP80B016-N9 16.33 x 19.03 x 1.14 (1 pc.)	
Screw-in cartridge - Viton	O-ring 14 x 1.78 (1 pc.)	15908100
	O-ring 17.17 x 1.78 (1 pc.)	
	O-ring 19.4 x 2.1 (1 pc.)	
	Back-up ring BBP80B015 14.73 x 17.43 x 1.14 (1 pc.)	
	Back-up ring BG1300174-PT00 17.4 x 1.3 (1 pc.)	
Model	Dimensions, quantity	Ordering number
Modular valve size 04 - NBR	Square ring 7.65 x 1.68 (4 pcs.)	15908200
Modular valve size 04 - Viton	O-ring 7.65 x 1.78 (4 pcs.)	22502600
Modular valve size 06 - NBR	Square ring 9.25 x 1.68 (4 pcs.)	15991700
Modular valve size 06 - Viton	O-ring 9.25 x 1.78 (4 pcs.)	22944700
Model	Typ, quantity	Ordering number
In-line valve RA1 - NBR	VSTI R1/4-ED (1 pc.)	22944600
	VSTI R3/8-ED (1 pc.)	
In-line valve RA2 - NBR	VSTI R1/4-ED (1 pc.)	22944400
	VSTI R1/2-ED (1 pc.)	
In-line valve RB1 - NBR	VSTI R1/4-ED (1 pc.)	22944500
In-line valve RB2 - NBR		
In-line valve RA1 - Viton	VSTI R1/4-ED - Viton (1 pc.)	22944300
	VSTI R3/8-ED - Viton (1 pc.)	
In-line valve RA2 - Viton	VSTI R1/4-ED - Viton (1 pc.)	22944100
	VSTI R1/2-ED - Viton (1 pc.)	
In-line valve RB1 - Viton	VSTI R1/4-ED - Viton (1 pc.)	22944200
In-line valve RB2 - Viton		

Preferred Types of Valves

Type	Ordering Number	Type	Ordering Number
VPP2-04/S-10	15906300	VPP2-04/MP06-10	15909300
VPP2-04/S-25	15906700	VPP2-04/MP06-25	15911600
VPP2-04/S-32	15907000	VPP2-04/MP06-32	15912700
VPP2-04/MP04-10	22507400	VPP2-04/RA2-10	22509900
VPP2-04/MP04-25	15911100	VPP2-04/RA2-25	22516100
VPP2-04/MP04-32	15912100	VPP2-04/RA2-32	22519400

Caution!

- The packing foil is recyclable.
- The protecting plate can be returned to the manufacturer.
- Mounting studs must be ordered separately. Tightening torques are: size 04 - 5 Nm, size 06 - 8.9 Nm.
- The technical information regarding the product presented in this catalogue is for descriptive purposes only. It should not be construed in any case as a guaranteed representation of the product properties in the sense of the law.

ARGO-HYTOS s.r.o. CZ - 543 15 Vrchlabí
 Tel.: +420-499-403111, Fax: +420-499-403421
 E-mail: sales.cz@argo-hytos.com
 www.argo-hytos.com

- Screw-in cartridge, modular and in-line design
- Six pressure ranges
- Four pressure adjustment options
- Subplates - see catalogue HA 0002

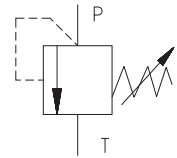

3

Functional Description

Pressure relief valves VPP2-06 were designed for applications requiring a safety valve or a pressure regulating valve working over a wide range of pressures and flow rates.

The valve basically consists of the valve body (1), poppet with damping spool (2) and compression spring (3). Pressure is manually set by an adjustment screw (4). The spring pushes the poppet into the seat (5) holding the valve in its normally closed position. When the force, caused by the pressure acting on the exposed surface area of the poppet, exceeds the spring force, the valve opens and the flow passes from port P to port T.

To optimize the valve performance, five pressure ranges are available. Choosing the closest range is recommended. The design enables the valve to be used as a screw-in cartridge for manifold mounting, built into a threaded housing or in a subplate mounted housing. Both the threaded and the subplate mounted housings can be delivered either with metric or pipe threads. The basic surface treatment of the valve body and the adjustment screw are zinc coated.

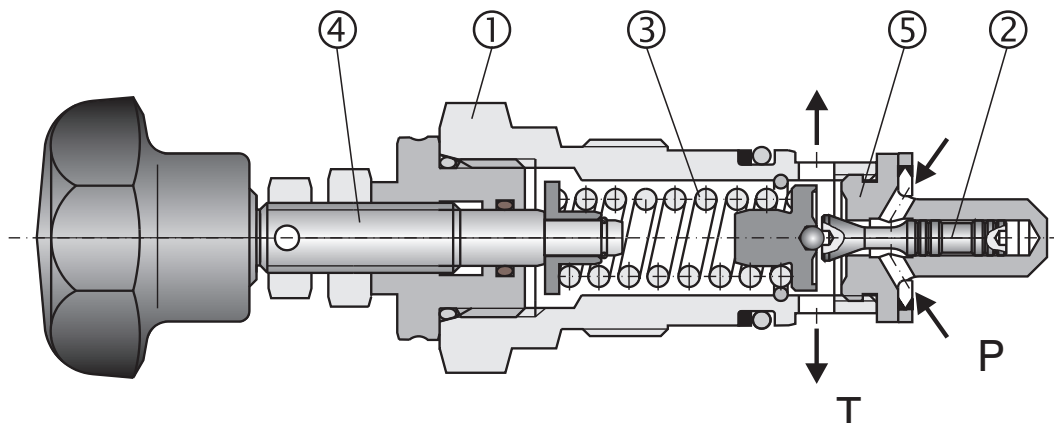

Ordering Code

VPP2-06 /

Direct Operated Relief Pressure Valves

without designation

Seals
NBR

Nominal size

2,5
6,3
10
16
25
32

Pressure range
up to 25 bar
up to 63 bar
up to 100 bar
up to 160 bar
up to 250 bar
up to 320 bar

Adjustment option

- Hexagon set screw locknut 5 mm
- Adjustable handknob
- Non-lockable cylindrical handknob
- Lockable cylindrical handknob

S
R
O
Z

V
M
G
P

Model

- screw-in cartridge valve
- cartridge in threaded housing - with metric threads
- cartridge in threaded housing - with BSP threads
- cartridge in subplate mounted housing

Technical Data

Nominal size	mm	06
Maximal flow rate	L/min	50
Max. service pressure ports (P, T, A, B)	bar	350
Working pressure related to flow	bar	see p-Q characteristics
Hydraulic fluid		Hydraulic oils of power classes (HL, HLP) to DIN 51 524
Fluid temperature range for standard sealing (NBR)	°C	-30 ... +100
Viscosity range	mm ² /s	20 ... 400
Maximum degree of fluid contamination		Class 21/18/15 to ISO 4406
Weight	kg	0,4 1,5
Mounting position		unrestricted

3

p-Q Characteristics

Measured at $v = 32 \text{ mm}^2/\text{s}$

Pressure range 2,5

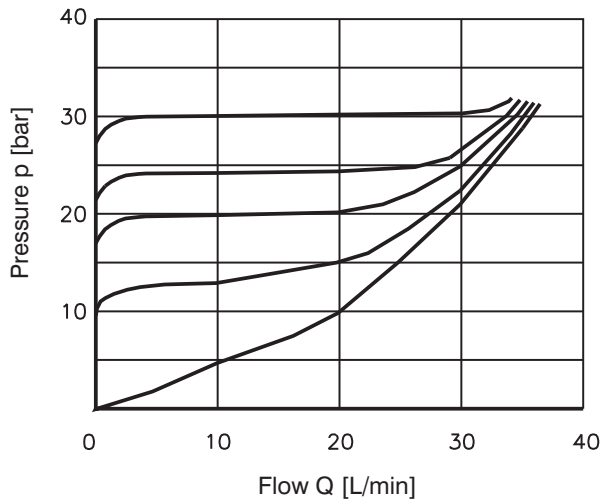

Pressure range 6,3

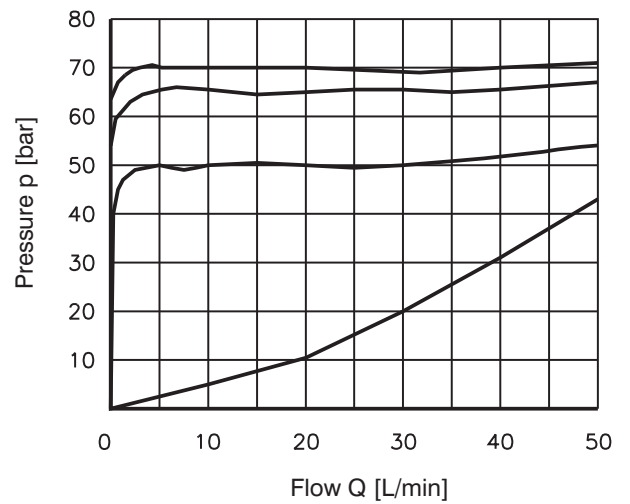

Pressure range 10

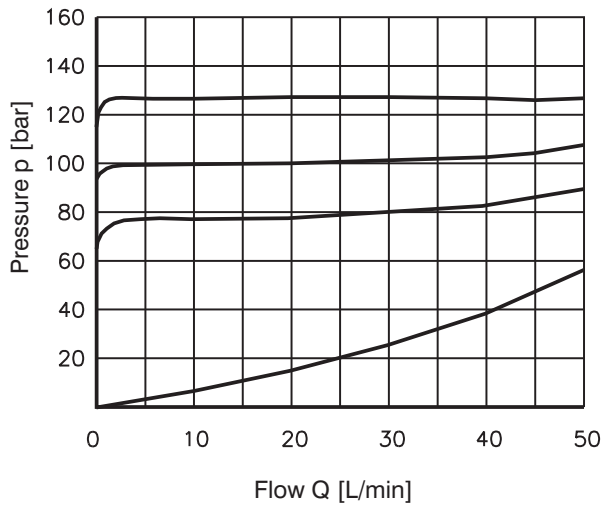

Pressure range 16

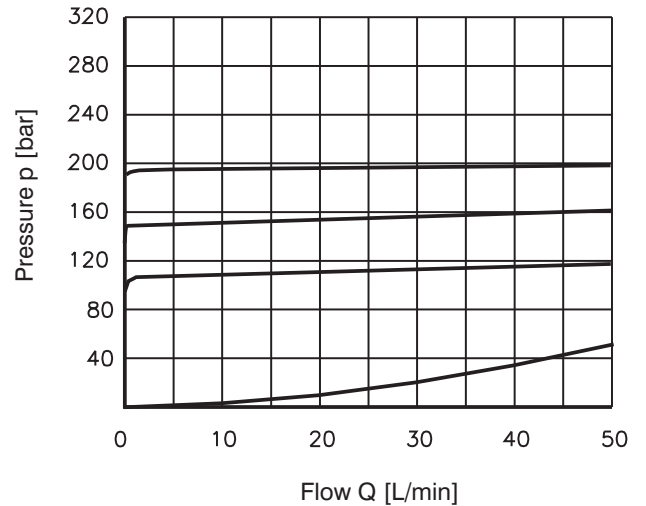

Pressure range 25

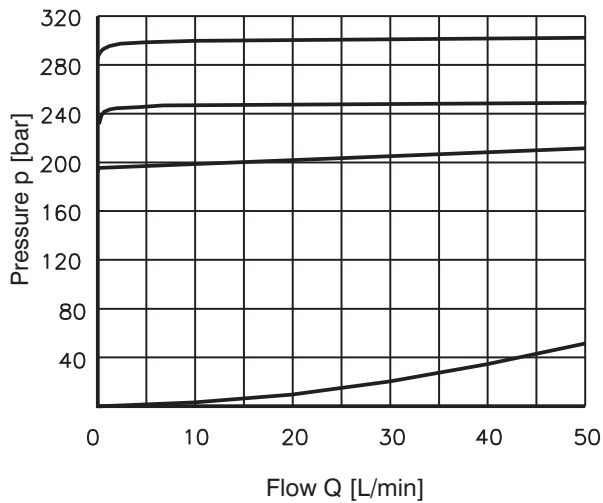

Pressure range 32

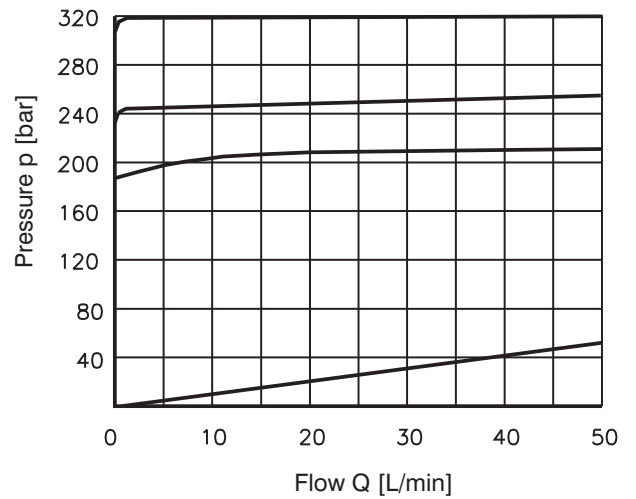

3

Valve Dimensions

Dimensions in millimeters

Cartridge valve - model "V"

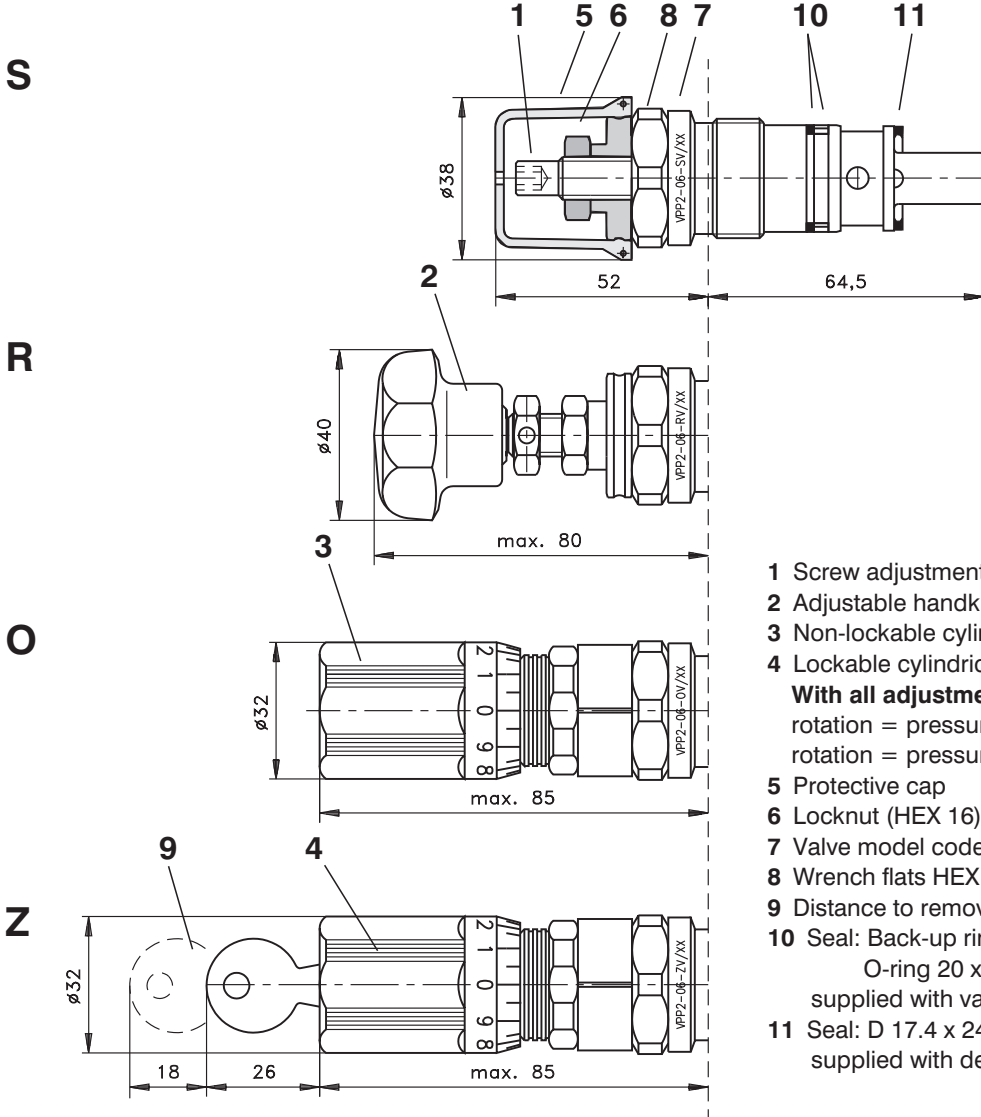

- 1 Screw adjustment model "S" (inside HEX 5)
 - 2 Adjustable handknob model "R"
 - 3 Non-lockable cylindrical handknob model "O"
 - 4 Lockable cylindrical handknob model "Z"
- With all adjustmen mechanisms:**
 rotation = pressure decrease
 rotation = pressure increase
- 5 Protective cap
 - 6 Locknut (HEX 16)
 - 7 Valve model code engraved
 - 8 Wrench flats HEX 32, tightening torque 80 Nm
 - 9 Distance to remove the key
 - 10 Seal: Back-up ring M8-116
O-ring 20 x 2.65 NBR70
supplied with valve
 - 11 Seal: D 17.4 x 24 x 1.5-NSA
supplied with delivery

Cavity

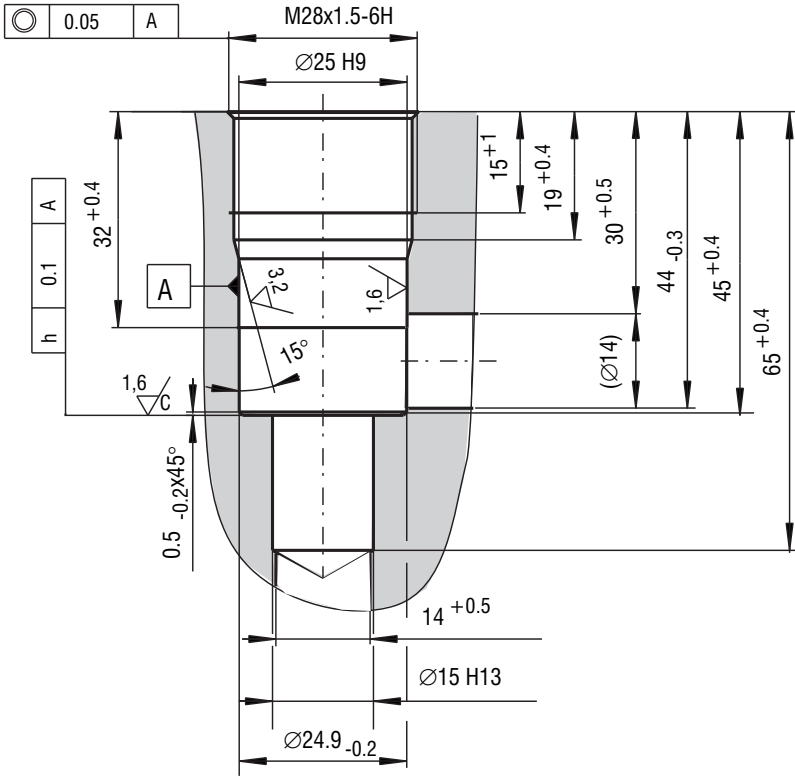

Valve Dimensions

Dimensions in millimeters

Cartridge in threaded housing - models „M“ and „G“

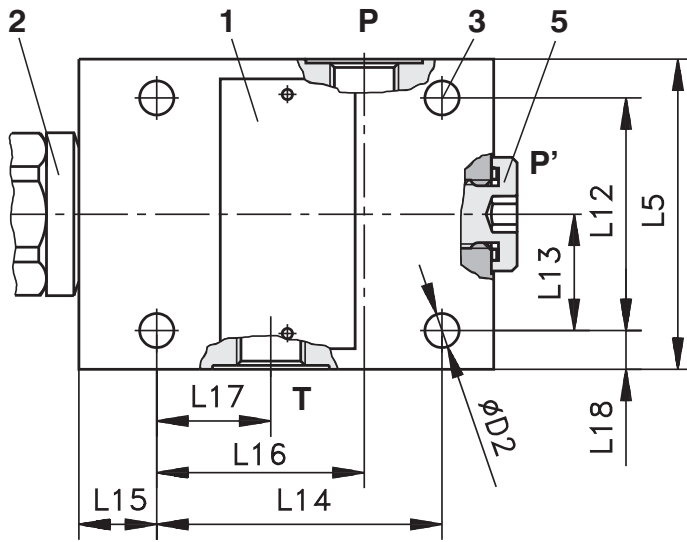
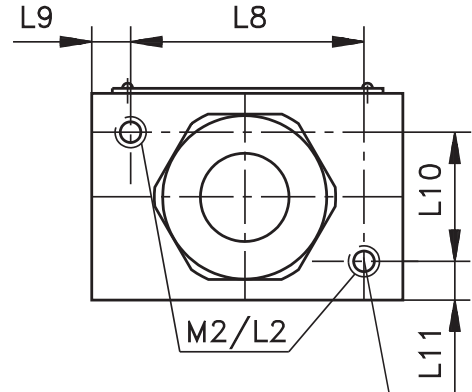
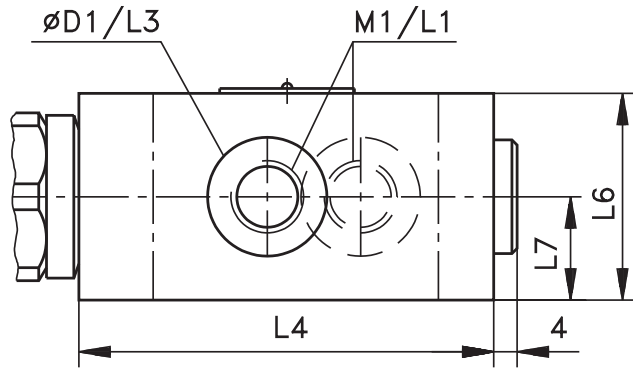

- 1 Name plate
- 2 Adjustment mechanism - see page 4
- 3 4 mounting through - holes
- 4 2 threaded holes
- 5 Port P' (either P or P' can be used as input port), thread M1 / L1

Model	M1	M2	D1	D2	L1	L2	L3	L4	L5	L6	L7
VPP2-06-xM/x	M14x1,5	M6	25	6.6	12	10	0.5	80	60	40	20
VPP2-06-xG/x	G1/4										

Model	L8	L9	L10	L11	L12	L13	L14	L15	L16	L17	L18
VPP2-06-xM/x	45	7.5	25	7.5	45	22.5	55	15	40	20	7.5
VPP2-06-xG/x											

3

Valve Dimensions

Dimensions in millimeters

Cartridge in subplate mounted housing - model „P“

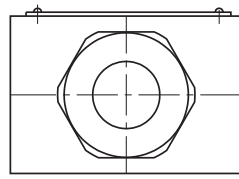
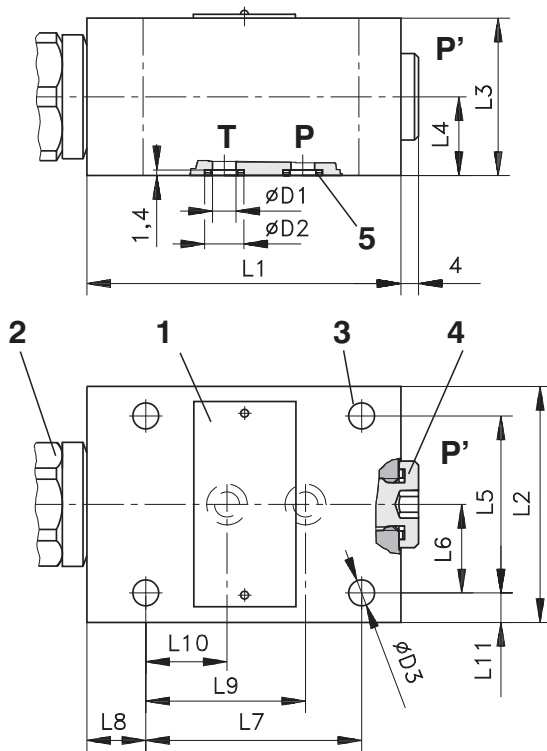

- 1 Name plate
- 2 Adjustment mechanism - see page 4
- 3 4 mounting through - holes
- 4 Port P' (e.g. for pressure measuring), thread M14 x 1,5 deep 12 mm
- 5 Square ring:
DKAR 00011 [7,65x1,68 (2 pcs.)]

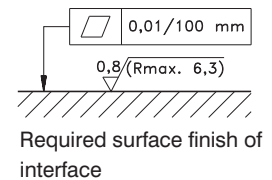

Note: Subplates - see catalog HA 0002

Model	D1	D2	D3	L1	L2	L3	L4	L5	L6	L7	L8	L9	L10	L11
VPP2-06-xP/x	6	10.8	6.6	80	60	40	20	45	22.5	55	15	40	20	7.5

Spare Parts

Accessories (delivered with subplate model „P“)

Bolt kit	Square ringe
M6x50 DIN 912-10.9 (4 pcs.) Tightening torque 8,9 Nm (6.6ft-lbf)	DKAR 00011 7,65 x 1,68 (2 pcs.)

Seak kit for cartridge valve

Type	Dimensions, quantity			Ordering number
	O-ring	Back-up ring	U-Seal	
Standard NBR	20 x 2,65 (1 pc.)	19,43 x 23,79 x 1,14 (1 pc.)	17,4 x 24 x 1,5 (1 pc.)	16757100

Caution!

- The packing foil is recyclable.
- The protective plate can be returned to manufacturer.
- Tightening torque of the screws is 8.9 Nm.
- The technical information regarding the product presented in this catalogue is for descriptive purposes only. It should not be construed in any case as a guaranteed representation of the product properties in the sense of the law.

ARGO-HYTOS s.r.o. CZ - 543 15 Vrchlabí
Tel.: +420-499-403111, Fax: +420-499-403421
E-mail: sales.cz@argo-hytos.com
www.argo-hytos.com

Declaration of Conformity according to Act No. 22/1997, Coll., CE 1017

- The product has been certified by TÜV SÜD Czech s.r.o.
- The product is supplied together with the Declaration of Conformity according to Act No. 22/1997, Coll., CE 1017
- Each product is supplied with the "Instructions for use of the safety valve" VPP2-06-SV/xx-CE1017"
- Single-stare pressure relief valve
- Screw-in cartridge valve

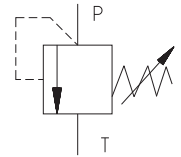

3

Functional Description

Pressure relief valves VPP2 were designed for applications requiring a safety valve or a pressure regulating valve working over a wide range of pressures and flow rates.

The valve consists of the valve body (1), poppet with damping spool (2) and compression spring (3). Pressure is manually set by an adjustment screw (4). The spring pushes the poppet into the seat (5) holding the valve in its normally closed position. When the force, caused by the pressure acting on the exposed surface area of the poppet, exceeds the spring force, the valve opens and the flow passes from port P to port T.

Blackening is used as the product basic finish.

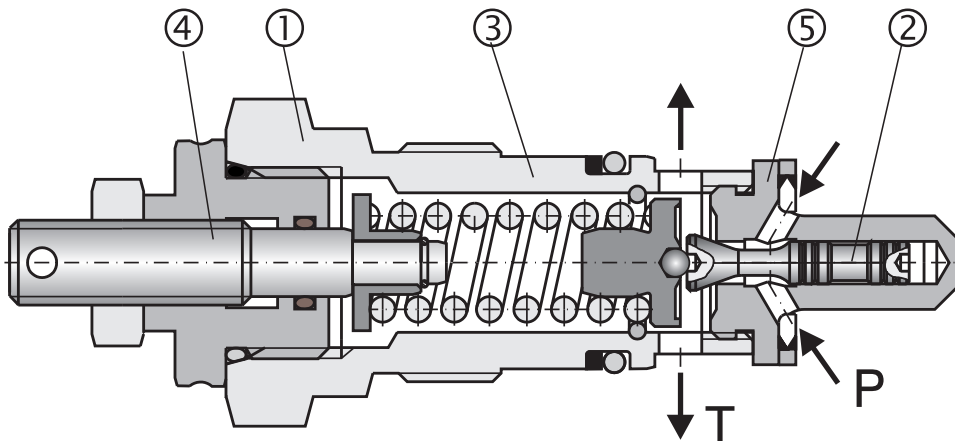

Technical Data

Valve size		06
Maximum flow	L/min (GPM)	50 (13.2)
Max. service pressure ports (P, T)	bar (PSI)	320 (4600)
Working pressure related to flow	bar (PSI)	see p-Q characteristics
Hydraulic fluid		Hydraulic oils of power classes (HL, HLP) to DIN 51 524
Fluid temperature range for standard sealing (NBR)	°C (°F)	-30 ... +100 (-22 ... +212)
Viscosity range	mm ² /s (SUS)	20 ... 400 (98 ... 1840)
Maximum degree of fluid contamination		Class 21/18/15 to ISO 4406
Weight	kg (lbs)	0,4 (0.879)
Mounting position		unrestricted

Ordering Code

VPP2-06-S V/ - CE1017- -

Directly Operated Relief Pressure Valves

Setting at flow rate (L/min)

Adjusted pressure (MPa)

Valve size

Declaration of Conformity
according to Act No. 22/1997, Coll., CE 1017

Adjustment option

Hexagon set screw locknut 5mm

2
6
10
16
25
32

Pressure range in bar (PSI)

Max. up to 25 (360)

Max. up to 63 (910)

Max. up to 100 (1450)

Max. up to 160 (2300)

Max. up to 250 (3600)

Max. up to 320 (4600)

Model

Screw-in cartridge valve

If not preset valves are ordered, pressure and flow rate information is not shown.

Valves adjusted at the manufacturer

- The valves are adjusted for the specified pressure at the relevant flow rate and they are fitted with tamper-indicating seals. The pressure and flow rate values are indicated in the valve description on the product [pressure: in MPa, flow rate in L/min].
- The seals bear the company logo

Not preset Valves at the manufacturer

- These valves have no tamper-indicating seals.
- No adjusted pressure and flow rate are indicated for not preset valves - VPP2-06-SV/xx-CE1017.
- After the completion of the functional test, the adjusting screw is completely loosened and the pressure is set to $p = 0$ bar.
- For the adjustment of the valve required pressure, proceed as follows:
 - by turning the adjusting screw to the right (position 4), the pressure is increasing;
 - by turning to the left, the pressure is decreasing.
- The manufacturer accepts no responsibility for the adjustment, securing and sealing the valve.

Residual risks

Preventive measures against the occurrence of residual risks

a) Use and performance properties

- The product may be used only within the range of parameters as set out herein.
- The parameters of the source of the operating pressure liquid must not exceed the valve maximum parameters. The selected range of valve setting (pressure level) must correspond to the intended use.

b) Identification and adjustment

- The product type marking must remain clearly visible.
- The valve adjustment, as guaranteed by the manufacturer, must not be changed.
- No damage and/or removal of the manufacturer's tamper-indicating seal are permissible.

c) Handling and storage

- Any valve dismantling by the customer is strictly forbidden.
- While handled and stored, the valve must be protected against any damage, corrosion or contamination.

d) Installation

- Dimensions and geometry of the valve chamber must correspond to the drawing shown herein.
- Before the installation, the valve and the chamber must be protected against contamination.
- The valve external gasket must not be damaged.
- Sealing surfaces in the chamber must not be damaged.
- In order to prevent any damage, adequate tools must be used for the valve installation.
- If fitted into a block, the tightening torque specified for the valve must be observed.

e) In service

- The working liquid in the circuit must meet the approved level of purity.
- While under pressure, any handling with the valve is prohibited. An exception from this rule is the adjustment of the opening pressure in the case of valves not preset at the manufacturer's place.
- The adjusting screw position must be secured by tightening of the safety nut.
- Any damaged or leaking valve, as well as any valve affected by corrosion or showing a function loss or malfunction must be immediately withdrawn from the service and replaced by a fully functional one.

p-Q Characteristic

Measured at $\nu = 32 \text{ mm}^2/\text{s}$ (156 SUS)

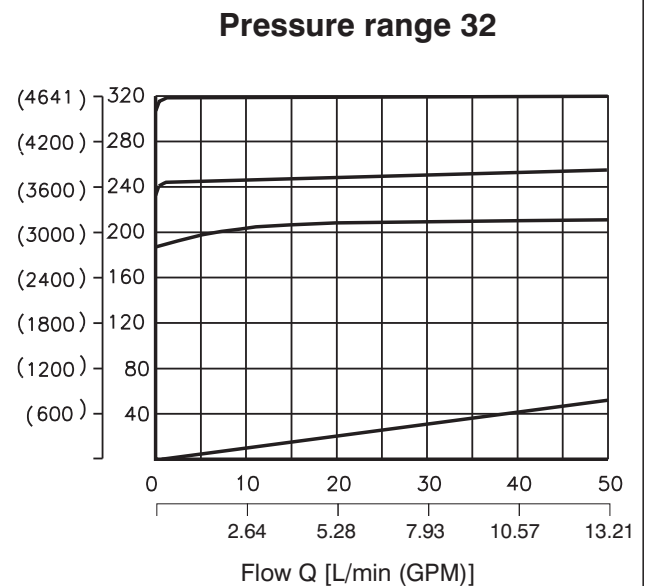
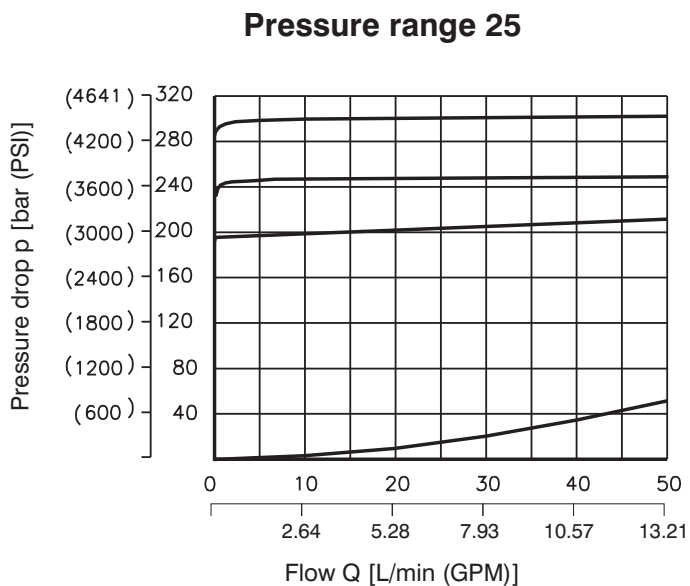
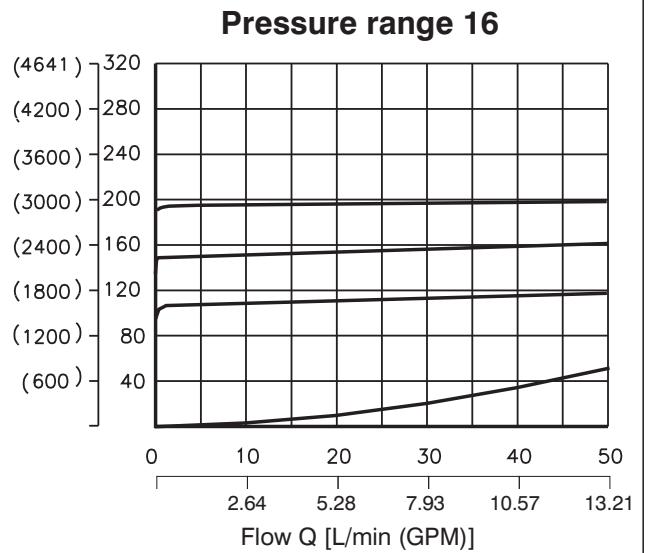
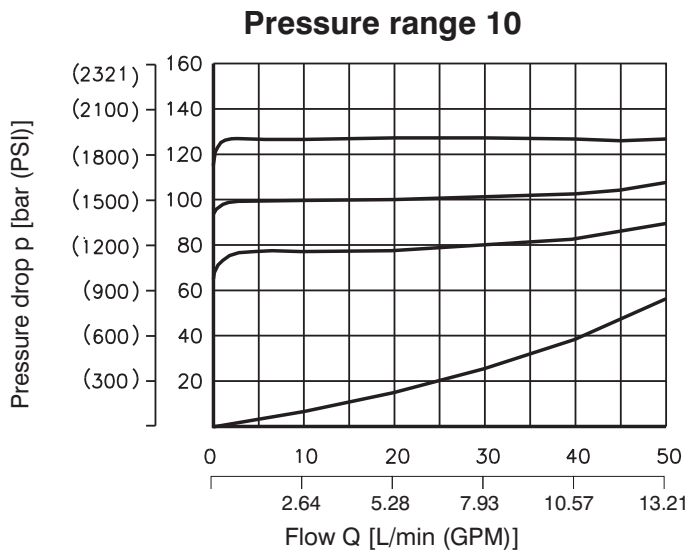
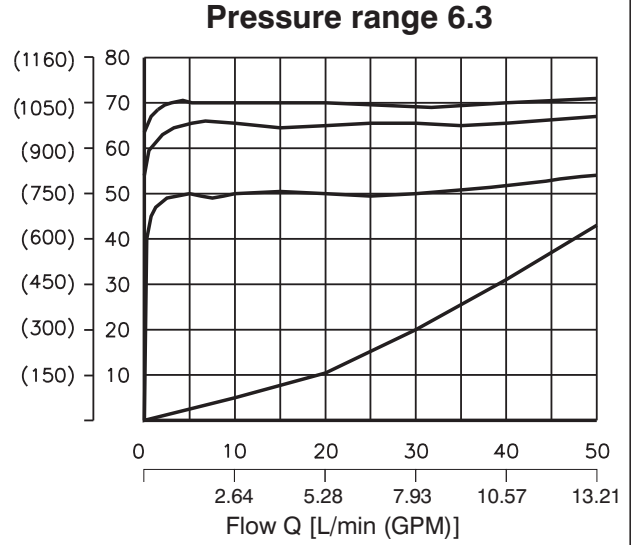
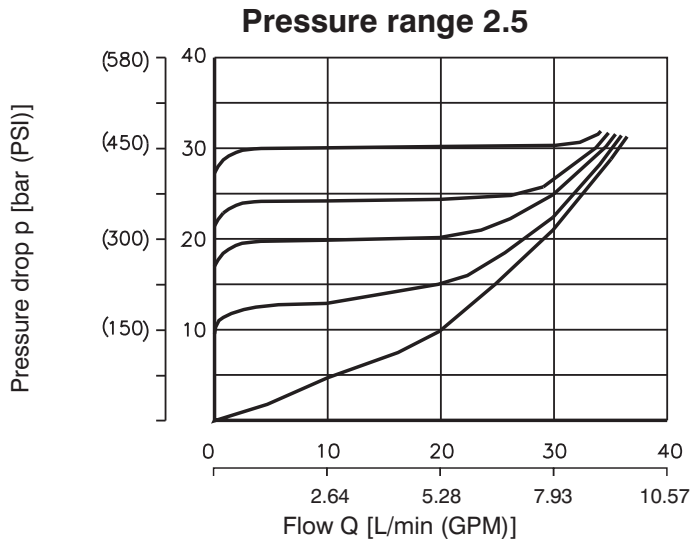

3

Valve Dimensions

Dimensions in millimeters (inches)

Cartridge valve - model „V“

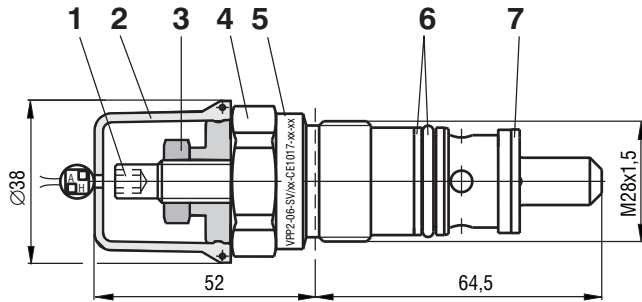

- 1 Screw adjustment model „S“ (inside HEX 5)
- 2 Protective cap
- 3 Locknut HEX16
- 4 Wrench flats HEX 32
Tightening torque 80 Nm (59ft-lbf)
- 5 Distance to remove the key
- 6 Seal: Back-up ring M8-116
O-ring 20 x 2,65 NBR70
supplied with valve
- 7 Seal: D 17,4 x 24 x 1,5-NSA
supplied with valve

Cavity

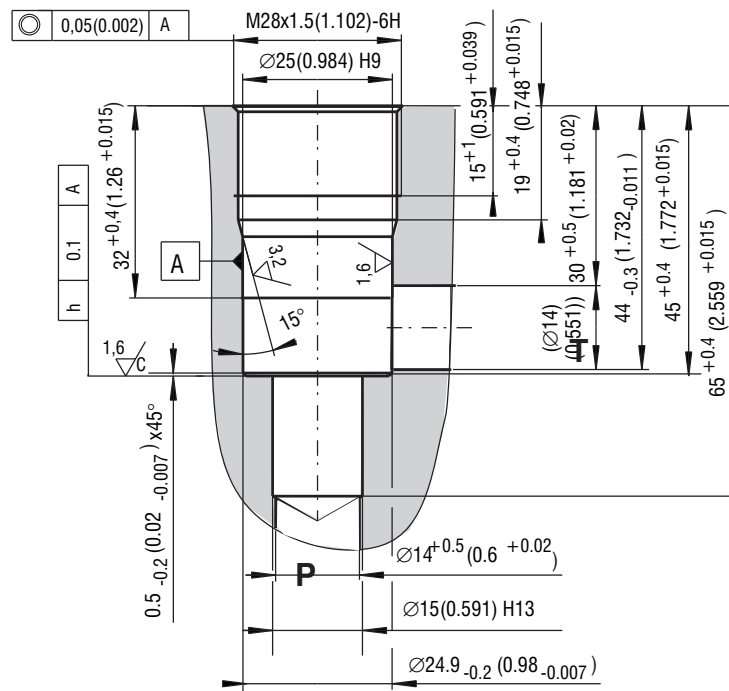

Spare Parts

Dimensions in millimeters

Seak kit for cartridge valve

Type	Dimensions, quantity			Order number
	O-ring	Back-up ring	U-Seal	
Standard NBR	20 x 2,65 (1 pc)	19,43 x 23,79 x 1,14 (1 pc)	17,4 x 24 x 1,5 (1 pc)	16757100

Caution!

- The packing foil is recyclable.
- The protective plate can be returned to manufacturer.
- The valves are wrapped in polyethylene bags (vacuum packed) and fitted with paper labels bearing the product number, name and manufacturing order.
- The valves should be stored in boxes and protected against weather effects that may cause corrosion.
- Except for the replacement of the external gasket, any other repairs of the valve are prohibited. They must be carried out at the manufacturer's place only.
- Any possibility of using the valve outside the range of the specified parameters must be consulted with the manufacturer. The technical information regarding the product presented in this catalogue is for descriptive purposes only. It should not be construed in any case as a guaranteed representation of the product properties in the sense of the law.

ARGO-HYTOS s.r.o. CZ - 543 15 Vrchlaví
 Tel.: +420-499-403111, Fax: +420-499-403421
 E-mail: sales.cz@argo-hytos.com
 www.argo-hytos.com

- Screw-in cartridge, modular and in-line design
- Six pressure ranges
- Four pressure adjustment options
- Subplates - see catalogue HA 0002

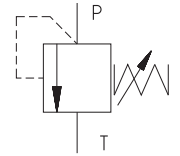

Functional Description

Pressure relief valves VPP1 were designed for applications requiring a safety valve or a pressure regulating valve working over a wide range of pressures and flow rates.

The valve basically consists of the valve body (1), poppet with damping spool (2) and compression spring (3). Pressure is manually set by an adjustment screw (4). The spring pushes the poppet into the seat (5) holding the valve in its normally closed position. When the force, caused by the pressure acting on the exposed surface area of the poppet, exceeds the spring force, the valve

opens and the flow passes from port P to port T. To optimize the valve performance, five pressure ranges are available. Choosing the closest range is recommended. The design enables the valve to be used as a screw-in cartridge for manifold mounting, built into a threaded housing or in a subplate mounted housing. Both the threaded and the subplate mounted housings can be delivered either with metric or pipe threads. The basic surface treatment of the valve body and the adjustment screw are zinc coated.

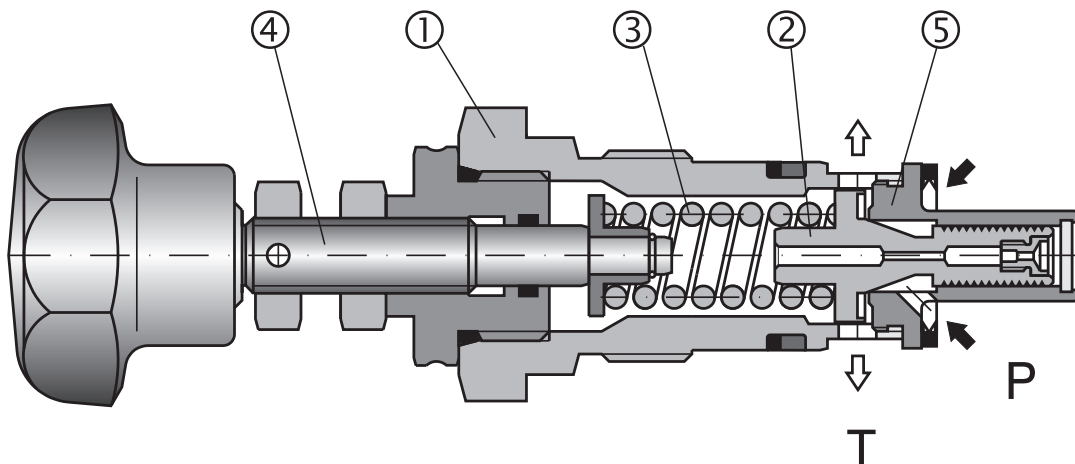

Ordering Code

VPP1-□-□□/□□

Direct Operated Relief Pressure Valve

without designation **Seals**
NBR

Nominal size
Size 06 **06**
Size 08 - only models M and G **08**
Size 10 **10**

Pressure range in bar
2,5 up to 25
6,3 up to 63
10 up to 100
16 up to 160
25 up to 250
32 up to 320

Adjustment option
Screw with internal hexagon **S**
Adjustable handknob **R**
Lockable cylindrical handknob **O**
Non-lockable cylindrical handknob **Z**

Model
screw-in cartridge valve **V**
cartridge in threaded housing - with metric threads **M**
cartridge in threaded housing - with BSP threads **G**
cartridge in subplate mounted housing **P**

Technical Data

Nominal size	mm	06	10
Maximum flow	L/min	50	120
Max. service pressure ports (P, T, A, B)	bar	350	
Working pressure related to flow	bar	see p-Q characteristics	
Hydraulic fluid		Hydraulic oils of power classes (HL, HLP) to DIN 51524	
Fluid temperature range for standard sealing (NBR)	(°C)	-30 ... +100	
Viscosity range	(mm ² /s)	20 ... 400	
Maximum degree of fluid contamination		Class 21/18/15 to ISO 4406	
Weight - screw-in cartridge valve other models	kg	0,4 1,5	0,5 3,7
Mounting position		unrestricted	

3

p-Q Characteristics

Measured at $v = 32 \text{ mm}^2/\text{s}$

Size 06

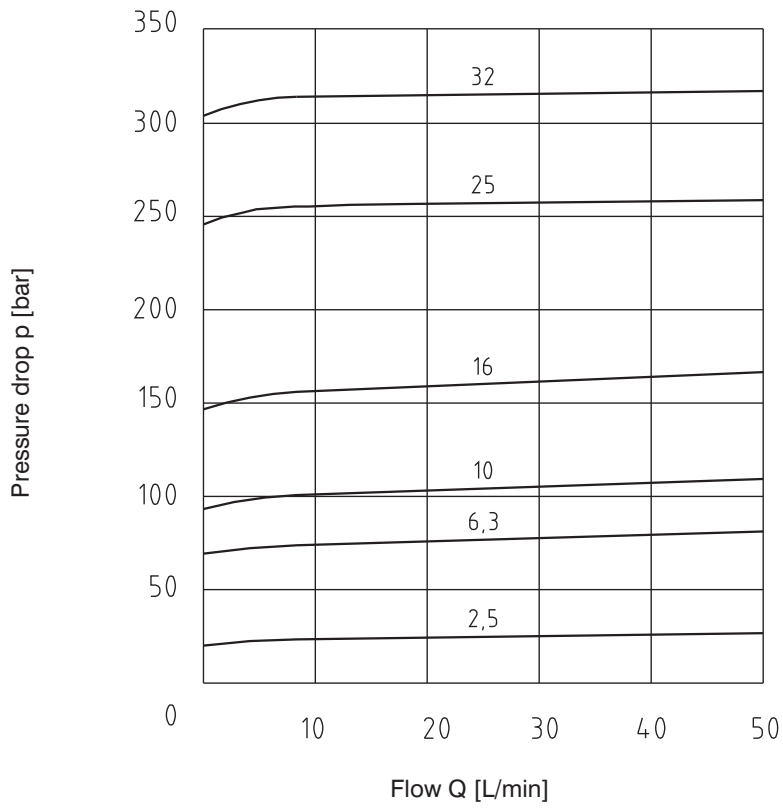

Size 10

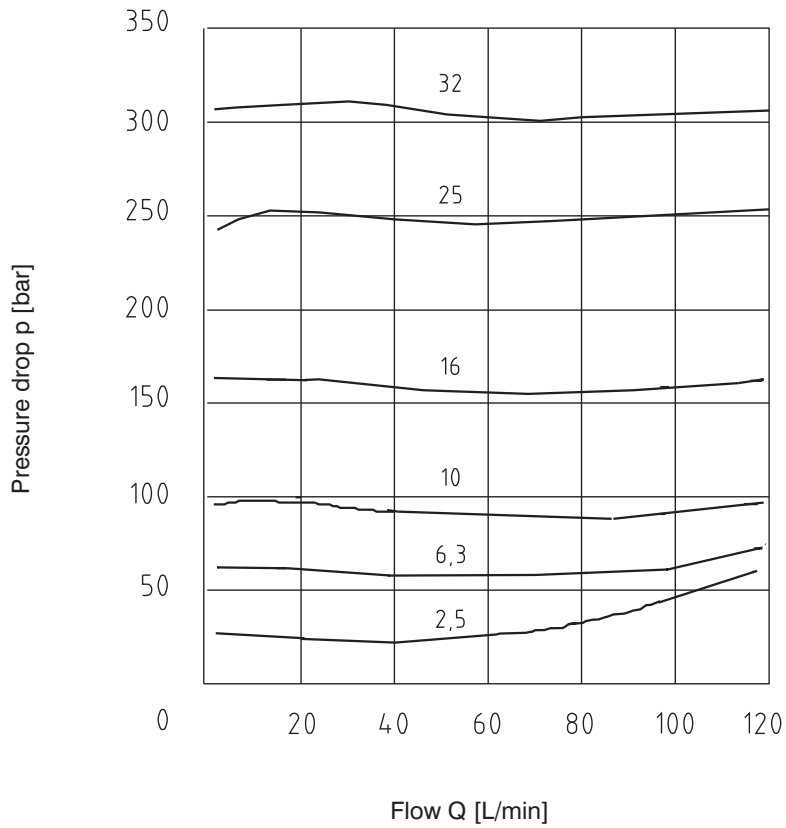

3

Valve Dimensions

Dimensions in millimeters

Cartridge valve - model „V“

S

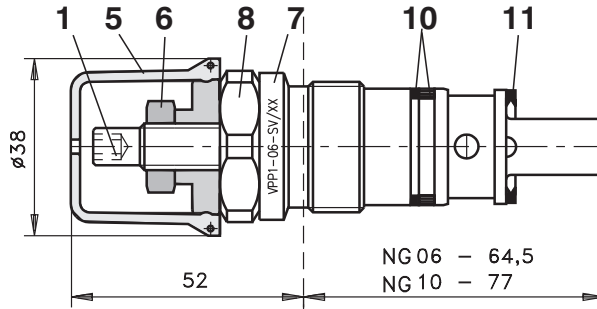

R

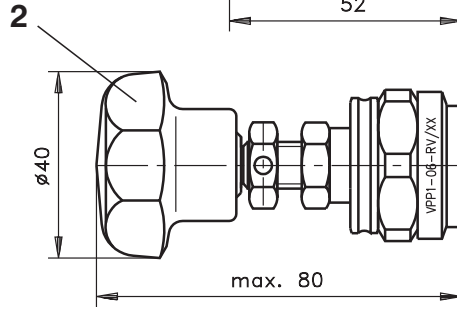

O

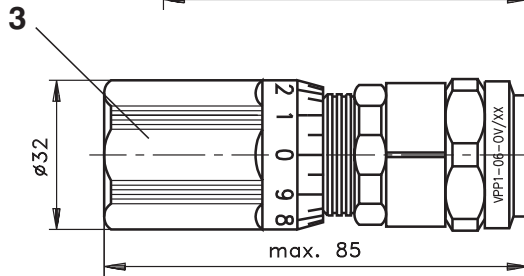

Z

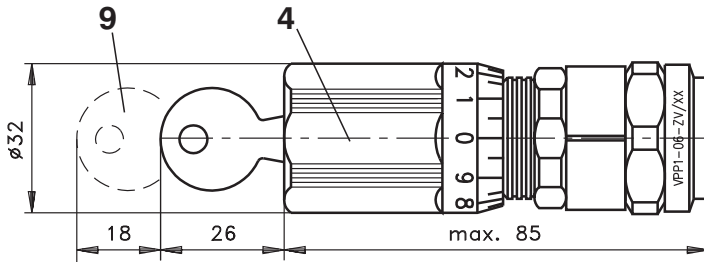

- 1 Screw adjustment model „S“ [inside HEX 5]
 - 2 Adjustable handknob model „R“
 - 3 Non-lockable cylindrical handknob model „O“
 - 4 Lockable cylindrical handknob model „Z“
- With all adjustment mechanisms:**
 rotation = pressure decrease
 rotation = pressure increase
- 5 Protective cap
 - 6 Locknut HEX 16
 - 7 Valve model code engraved
 - 8 Wrench flats HEX 32
Tightening torque 80 Nm for Size 06
Wrench flats HEX 36
Tightening torque 140 Nm for Size 10
 - 9 Distance to remove the key
 - 10 Seal:
Size 06: Back-up ring M8-116 (1 pc.)
O-ring 20x2.65 NBR70 (1 pc.)
Size 10: Back-up ring BBP80-B121-N9 (1 pc.)
O-ring 26.64x2.62 NBR70 (1 pc.)
 - 11 Seal:
Size 06: D 17.4x24x1.5-NSA (1 pc.)
Size 10: D 24.7x32x2 (adapted) (1pc.)

Cavity

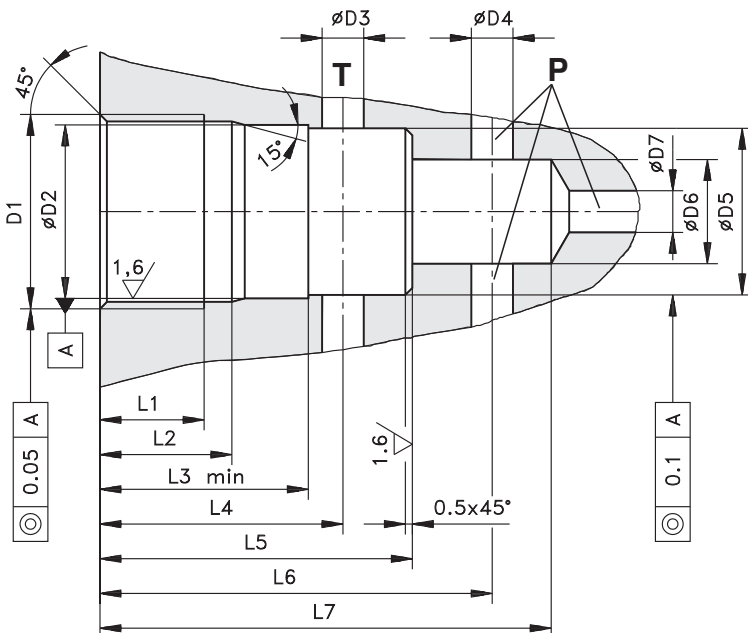

	Size 06	Size 10
	(mm)	(mm)
D1	M28 x 1,5	M35 x 1,5
∅D2	25 H9	32 H9
∅D3	6	10
∅D4	6	10
∅D5	24,9	31,9
∅D6	15	18,5
∅D7	6	10
L1	15	18
L2	19	21+0,4
L3	32	35
L4	35	41
L5	45	52
L6	56,5±5,5	67,5±7,5
L7	65	80

Cartridge in threaded housing - models „M“ and „G“

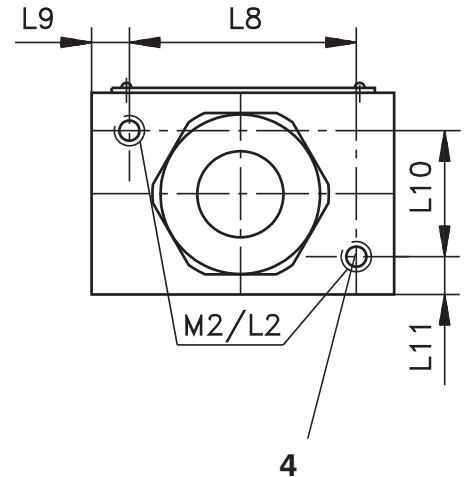
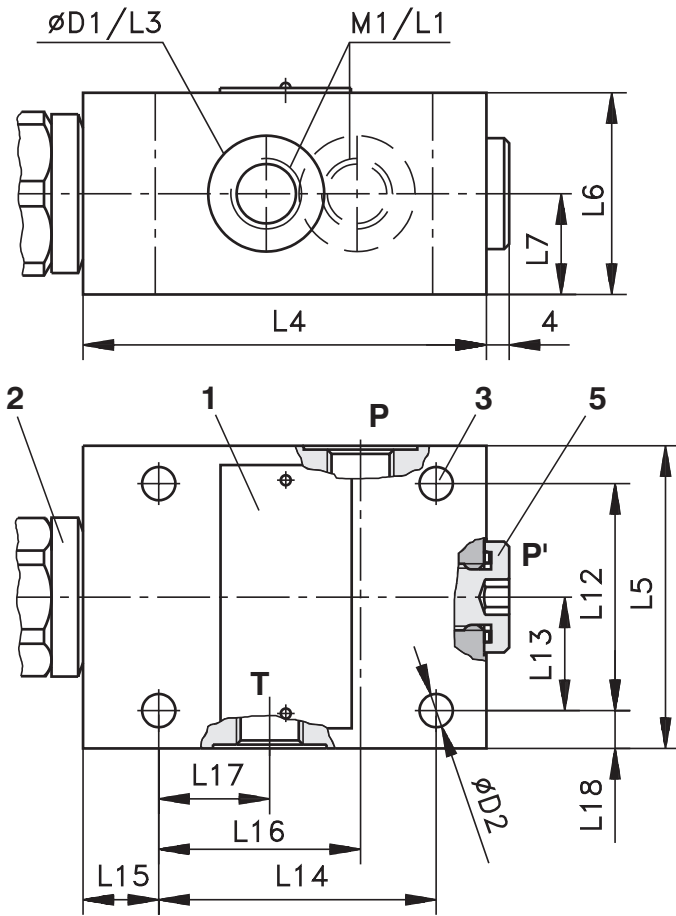

- 1 Name plate
- 2 Adjustment mechanism - see page 4
- 3 4 mounting holes
- 4 2 threaded holes (other mounting possibility)
- 5 Port P' (as input can be used P or P')
thread M1/L1

Model	M1	M2	ØD1	ØD2	L1	L2	L3	L4	L5	L6	L7
VPP1-06-xM/x	M14 x 1,5	M6	25	6,6	12	10	0,5	80	60	40	20
VPP1-06-xG/x	G 1/4										
VPP1-08-xM/x	M18 x 1,5	M8	30	9	16	20		100	80	60	30
VPP1-08-xG/x	G 3/8		28								
VPP1-10-xM/x	M22 x 1,5		34								
VPP1-10-xG/x	G 1/2										

Model	L8	L9	L10	L11	L12	L13	L14	L15	L16	L17	L18
VPP1-06-xM/x	45	7.5	25	7.5	45	22,5	55	15	40	20	7,5
VPP1-06-xG/x											
VPP1-08-xM/x	60	10	40	10	60	30	70	20	49	21	10
VPP1-08-xG/x											
VPP1-10-xM/x											
VPP1-10-xG/x											

Cartridge in subplate mounted housing - model „P“

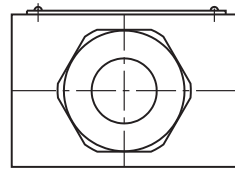
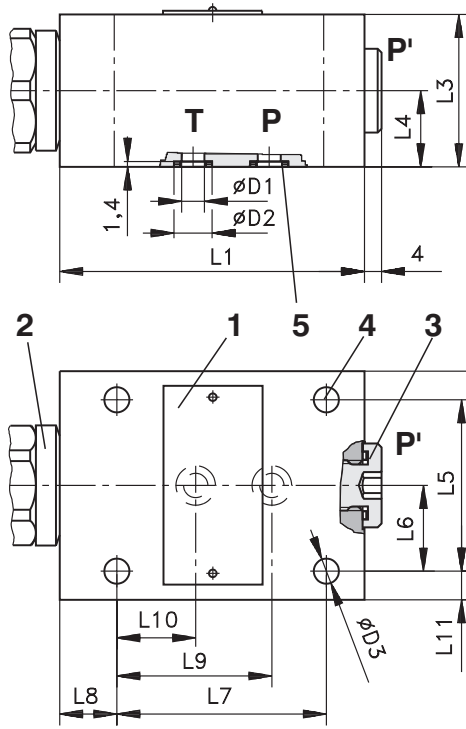

- 1 Name plate
- 2 Adjustment mechanism - see page 4
- 3 Port P', thread M1/H1 can be used as input pressure or for measuring
- 4 4 mounting holes
- 5 Square ring:
size 06 - DKAR 00011 [7.65x1.68 (2 pcs.)]
size 10 - DKAR 00014 [12.42x1.68 (2 pcs.)]

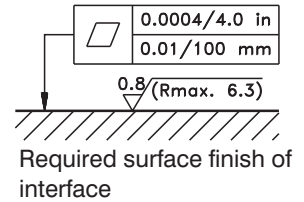

Note: Subplates - see catalog HA 0002

Model	M1	H1	ØD1	ØD2	ØD3	L1	L2	L3	L4	L5	L6	L7	L8	L9	L10	L11
VPP1-06-xP/x	G 1/4	12	6	10,8	6,6	80	60	40	20	45	22,5	55	15	40	20	7,5
VPP1-10-xP/x			10	15,6	9	100	80	60	30	60	30	70	20	45	21	10

Spare Parts

Accessories (delivered with subplate model „P“)

	Bolt kit	Square ringe
Size 06	M6x50 DIN 912-10.9 (4 pcs.) Tightening torque 8.9 Nm	DKAR 00011 7,65 x 1,68 (2 pcs.)
Size 10	M8x70 DIN 912-10.9 (4 pcs.) Tightening torque 15 Nm	DKAR 00014 12,42 x 1,68 (2 pcs.)

Seak kit for cartridge valve

Type	Dimensions, quantity			Ordering number
	O-ring	Back-up ring	U-Seal	
Size 06 Standard NBR	8 x 1,8 (1 pc.)	19,43 x 23,79 x 1,14 (1 pc.)	17,4 x 24 x 1,5 (1 pc.)	15972100
	20 x 2,65 (1 pc.)	-	-	
	20 x 2 (1 pc.)	-	-	
Size 10 Standard NBR	8 x 1,8 (1 pc.)	27,46 x 31,8 2 x1,1 (1 pc.)	24,7 x 30,8 x 2 (1 pc.)	15972200
	20 x 2 (1 pc.)	-	-	
	26,64 x 2,62 (1 pc.)	-	-	

Caution!

- The packing foil is recyclable.
- The protecting plate can be returned to the manufacturer.
- For applications outside these parameters, please consult the manufacturer.
- The technical information regarding the product presented in this catalogue is for descriptive purposes only. It should not be construed in any case as a guaranteed representation of the product properties in the sense of the law.

ARGO-HYTOS s.r.o. CZ - 543 15 Vrchlaví
Tel.: +420-499-403111, Fax: +420-499-403421
E-mail: sales.cz@argo-hytos.com
www.argo-hytos.com

- Screw-in cartridge design
- 4 pressure ranges
- Pressure setting by hexagon socket

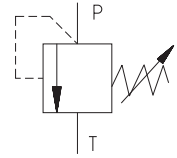

Functional Description

The directly operated pressure relief valve SR1A-A2 consists basically of the valve housing (1), ball with damping spool (2), damping bush (3), spring (4) and setting screw (5). The pressure setting is accomplished by setting screw (5) with hexagon socket. The spring pushes the ball into the valve seat created directly in the valve housing and holds the valve closed. When the pressure in port P exceeds the pressure magnitude set

by the setting screw, the ball is lifted up from the seat and the fluid flows out to port T. To optimize the valve performance, the whole pressure range is divided into 4 pressure ranges. Choosing the next higher pressure range is always recommended.

In basic version the valve housing and the setting screw are zinc coated.

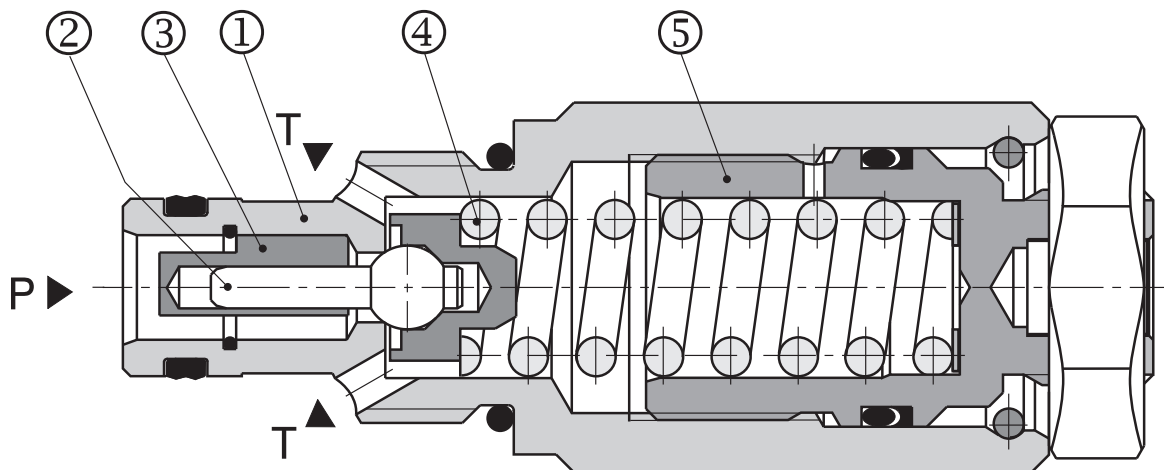

Ordering Code

SR1A-A2 /



Directly Operated Pressure Relief Valve
3/4-16 UNF

without designation
V

Seals
NBR
FPM (Viton)

Standard

S

10
16
25
35

Pressure range
up to 100 bar (1450 PSI)
up to 160 bar (2320 PSI)
up to 250 bar (3626 PSI)
up to 350 bar (5076 PSI)

Technical Data

Valve size	A2	
Cartridge cavity	3/4 -16 UNF-2A	
Max. flow rate	L/min (GPM)	30 (7.9)
Max. service pressure port P)	bar (PSI)	350 (5076)
Max. output pressure (port T)	bar (PSI)	160 (2320)
Working pressure related to flow	bar (PSI)	see p-Q characteristics
Hydraulic fluid	Hydraulic oils of power classes (HL, HLP) to DIN 51524	
Fluid temperature range for standard (NBR)	°C (°F)	-30 ... +100 (-22 ... 212)
Fluid temperature range for Viton FPM)	°C (°F)	-20 ... +120 (-4 ... 248)
Viscosity range	mm ² /s (SUS)	10 ... 500 (49 ... 2450)
Max. degree of fluid contamination	Class 21/18/15 according to ISO 4406	
Weight	kg (lbs)	0.13 (2.866)
Maximum valve tightening torque	Nm (lbf.ft)	30+2 (22.13+1.48 lbf.ft)
Mounting position	unrestricted	
Valve body (data sheet HA 0018)	SB-A2	

p-Q Characteristics

Measured at $v = 32 \text{ mm}^2/\text{s}$ (156 SUS)

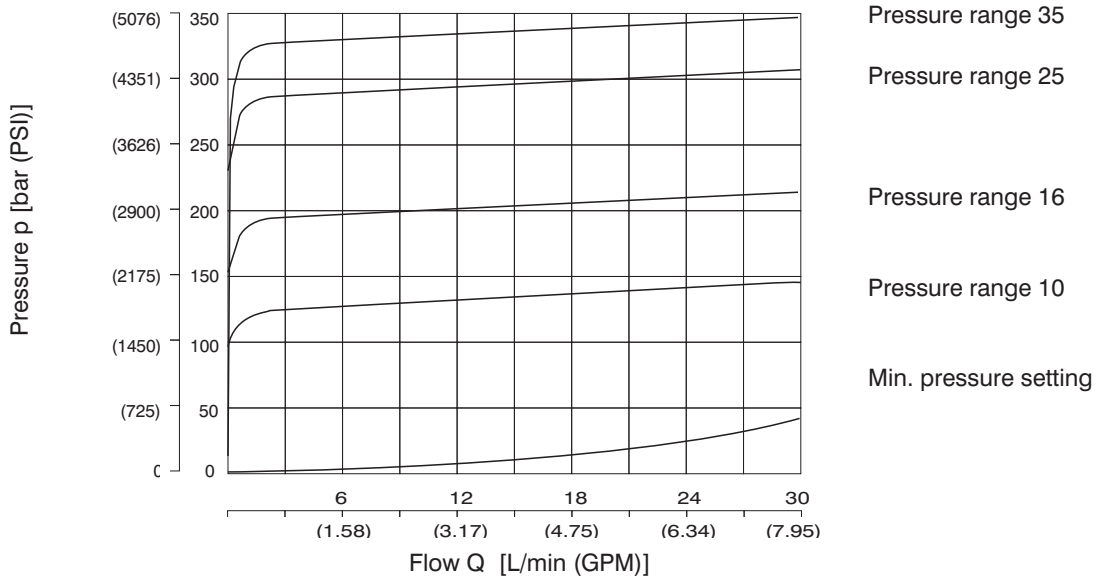

Valve Dimensions

Dimensions in millimetres (inches)

Screw-in Cartridge Design

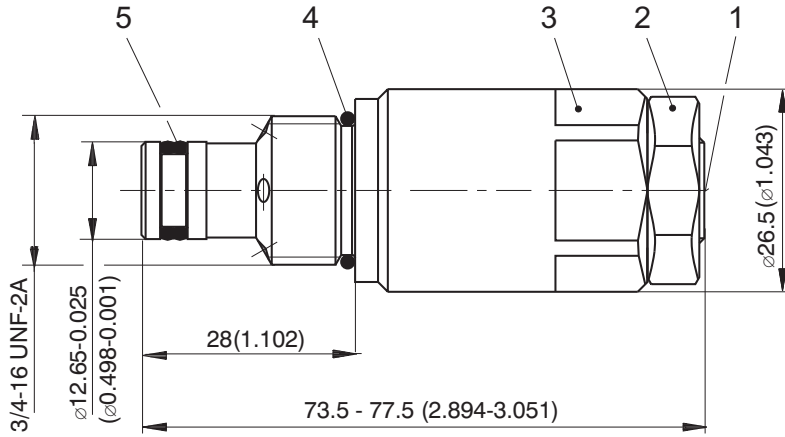

- 1** Adjustment element (screw with internal HEX 6)
Clockwise rotation = pressure increase
Anticlockwise rotation = pressure decrease
- 2** Locknut HEX 21
- tightening torque 15 Nm (11 lbf.ft)
- 3** Wrench flats HEX 24
- tightening torque 30 Nm (22 lbf.ft)
- 4** O-ring 17 x 1.8 (supplied with valve)
- 5** Combined sealing:
Dualseal DRYZ000004Z20
10.3 x 12.7 x 3.1 (supplied with valve)

Cavity

Dimensions in millimetres (inches)

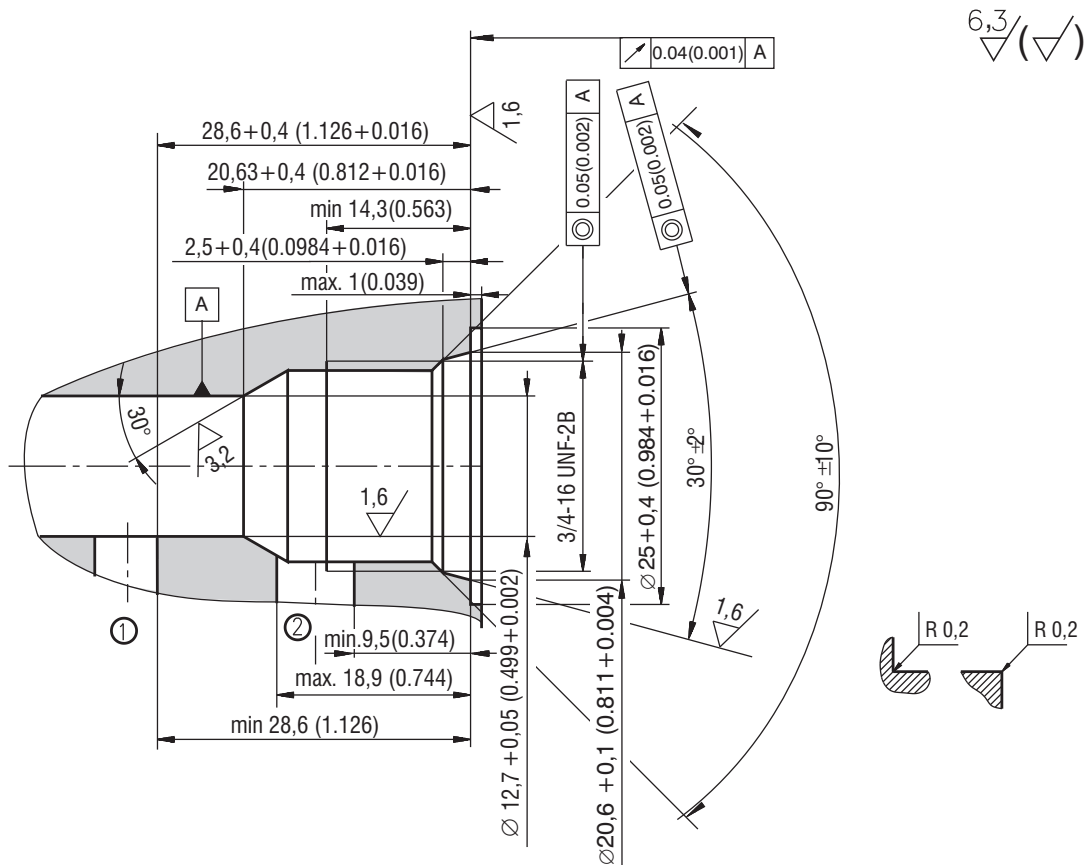

Spare Parts

Seal kit				Ordering number
Dualseal - PU 10.3 x 12.7 x 3.1 (1pc.)	O-ring - NBR 17 x 1.8 (1pc.)	O-ring - NBR 17.17 x 1.78 (1pc.)	Back-up ring - NBR 16.33 x 19.03 x 1.14 (1pc.)	22531100
Dualseal - PU 10.3 x 12.7 x 3.1 (1pc.)	O-ring - Viton 17.17 x 1.78 (2pcs.)		Back-up ring - Viton 16.33 x 19.03 x 1.14 (1pc.)	22531000

Caution!

- The packing foil is recyclable.
- The technical information regarding the product presented in this catalogue is for descriptive purposes only. It should not be construed in any case as a guaranteed representation of the product properties in the sense of the law.

ARGO-HYTOS s.r.o. CZ - 543 15 Vrchlaví
Tel.: +420-499-403 111
E-mail: info.cz@argo-hytos.com
www.argo-hytos.com

- Screw-in cartridge design
- 7 pressure ranges
- Pressure setting by
 - Hexagon set screw lock
 - Adjustable handknob

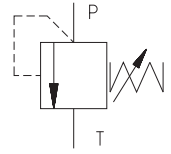

Functional Description

Directly operated pressure relief valves SR1A-B2 were designed for applications requiring a safety valve or a pressure regulating valve working over a wide range of pressures and flow rates. The valve basically consists of the valve body (1), poppet with damping spool (2), spring (3) and adjusting screw (4). The spring pushes the poppet into the seat (5) and holds the valve in its normally closed position. When the force, caused by the input pressure, exceeds the spring force, the valve opens and the flow passes from port P to port T.

To optimize the valve performance seven pressure ranges the valve are available. Choosing the closest range is recommended.

The design enables the valve to be used as a screw-in cartridge for manifold mounting, or in a subplate and/or in-line mounted housing.

The valve body and the adjustment screw are zinc coated.

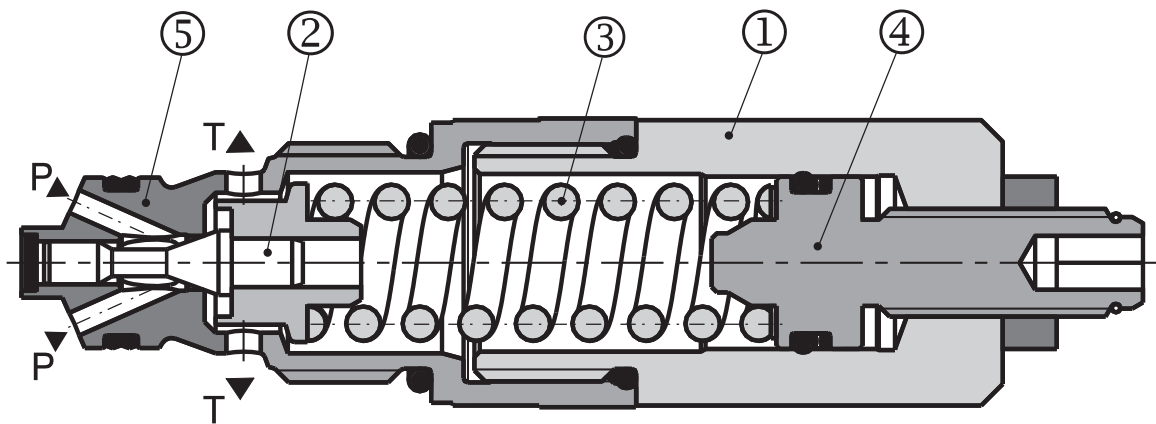

Ordering Code

SR1A-B2 /

**Directly Operated Pressure Relief Valve
7/8-14 UNF**

High performance

H

Pressure range

- up to 25 bar (363 PSI)
- up to 63 bar (914 PSI)
- up to 100 bar (1450 PSI)
- up to 160 bar (2321 PSI)
- up to 250 bar (3626 PSI)
- up to 350 bar (5076 PSI)
- up to 420 bar (6092 PSI)

- 2,5**
- 6,3**
- 10**
- 16**
- 25**
- 35**
- 42**

without designation

V

Seals

- NBR (Standard)
- FPM (Viton)

Adjustment option

- Hexagon set screw locknut 5 mm
- Adjustable handknob

**S
R**

Technical Data

Valve size		B2
Cartridge thread		7/8-14UNF-2A
Maximum flow	L/min (GPM)	60 (15.85)
Max. input pressure (port P)	bar (PSI)	420 (6092)
Max. output pressure (port T)	bar (PSI)	250 (3626)
Pressure drop	bar (PSI)	see Δp -Q characteristics
Hydraulic fluid		Hydraulic oils of power classes (HL, HLP) to DIN 51524
Fluid temperature range for standard sealing (NBR)	°C (°F)	-30 ... +100 (-22 ... 212)
Fluid temperature range for Viton sealing (FPM)	°C (°F)	-20 ... +120 (-4 ... 248)
Viscosity range	mm ² /s (SUS)	10 ... 500 (49 ... 2450)
Maximum degree of fluid contamination		Class 21/18/15 according to ISO 4406
Weight	kg (lbs)	0,25(0.55)
Maximum valve tightening torque	Nm (lbf.ft)	50+5 (36.88+3.68)
Mounting position		unrestricted
Valve body (data sheet HA 0018)		SB-B2

p-Q Characteristics

Measured at $v = 32 \text{ mm}^2/\text{s}$ (156 SUS)

Pressure drops related to flow rate.

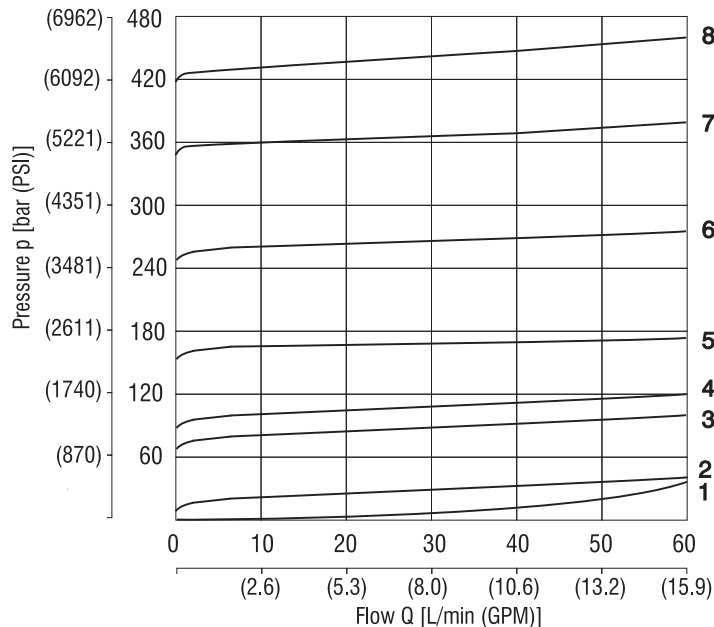

8	Pressure range 42
7	Pressure range 35
6	Pressure range 25
5	Pressure range 16
4	Pressure range 10
3	Pressure range 6,3
2	Pressure range 2,5
1	Min. pressure setting

Valve Dimensions

Dimensions in millimetres (inches)

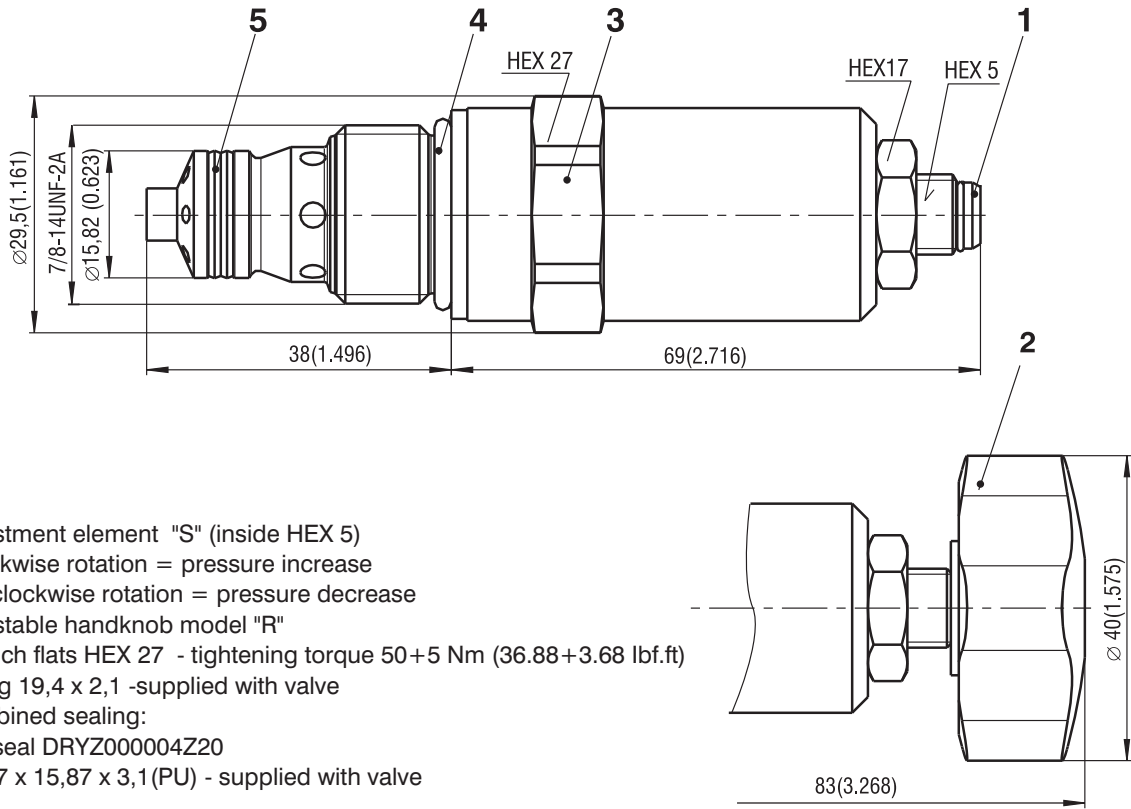

- 1 Adjustment element "S" (inside HEX 5)
 Clockwise rotation = pressure increase
 Anticlockwise rotation = pressure decrease
- 2 Adjustable handknob model "R"
- 3 Wrench flats HEX 27 - tightening torque 50+5 Nm (36.88+3.68 lbf.ft)
- 4 O-ring 19,4 x 2,1 -supplied with valve
- 5 Combined sealing:
 Dualseal DRYZ000004Z20
 13,47 x 15,87 x 3,1(PU) - supplied with valve

Cavity

Dimensions in millimetres (inches)

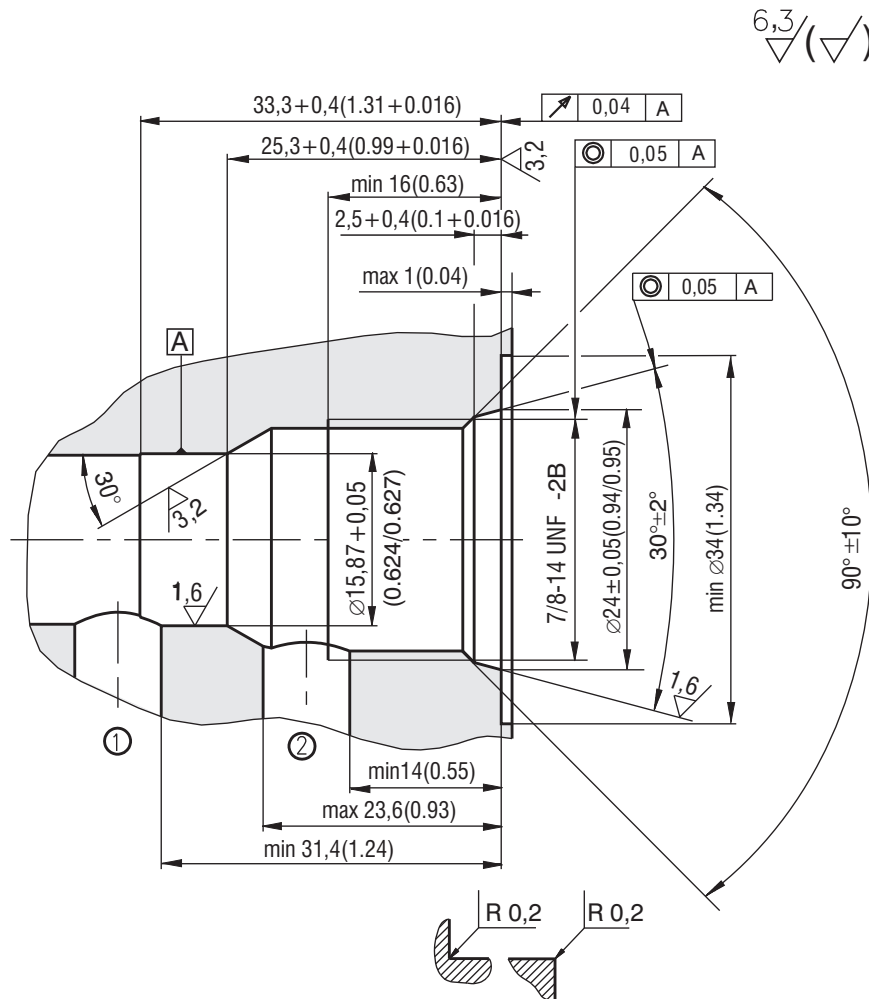

3

Spare Parts

Seal kit		Ordering number
Dualseal - PU	O-ring - NBR	18775600
DRYZ000002Z20 13,47 x 15,87 x 3,1 (1pc.)	19,4 x 2,1 (1pc.)	

3

Caution!

- The packing foil is recyclable.
- The technical information regarding the product presented in this catalogue is for descriptive purposes only. It should not be construed in any case as a guaranteed representation of the product properties in the sense of the law.

ARGO-HYTOS s.r.o. CZ - 543 15 Vrchlabí
 Tel.: +420-499-403 111
 E-mail: info.cz@argo-hytos.com
 www.argo-hytos.com

- Screw-in cartridge design
- 5 pressure ranges
- Pressure setting by
 - Hexagon set screw lock
 - Adjustable handknob

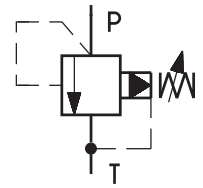

Functional Description

Pressure relief valves SR4A-B2 are pilot operated pressure valves designed for system pressure limitation. The pressure adjustment provides the adjustment screw (4). In its basic state, the valve is closed. The pressure acts on the face area of the control spool (1) and at the same time through orifice (2) on the control spool rear side, which is preloaded by a spring and further on through orifice (3) on the pilot valve ball (6). When the increasing system pressure reaches the value, which is preset by spring (5), the valve opens and the

control flow passes through the pilot valves. The spool area which is preloaded by the spring becomes relieved, the spool control edge opens the radial bores in bushing (7) and the fluid passes from port P to T. The control flow is routed through groove to channel T.

The valve body and the adjustment screw are zinc coated.

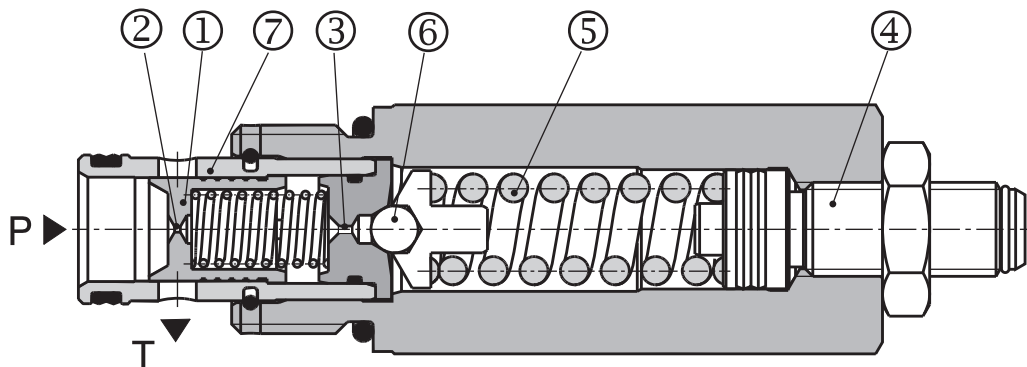

Ordering Code

SR4A-B2 /

**Pilot Operated Pressure Relief Valve
7/8 -14 UNF**

Standard

S

Pressure range

- up to 63 bar (914 PSI)
- up to 100 bar (1450 PSI)
- up to 160 bar (2320 PSI)
- up to 250 bar (3626 PSI)
- up to 350 bar (5076 PSI)

- 6,3**
- 10**
- 16**
- 25**
- 35**

without designation

V

Seals

- NBR
- FPM (Viton)

Adjustment option

- Hexagon set screw locknut 5mm
- Adjustable handknob

S
R

Technical Data

Valve size	B2				
Cartridge thread	7/8 -14 UNF-2A				
Max. flow rate	L/min (GPM)	100 (26.4)			
Max. input pressure (port P)	bar (PSI)	6.3 (914)	100 (1450)	160 (2320)	250 (3626) 350 (5076)
Max. output pressure (port T)	bar (PSI)	100 (1450)			
Working pressure related to flow	bar (PSI)	see p-Q characteristics			
Hydraulic fluid	Hydraulic oils of power classes (HL, HLP) to DIN 51524				
Fluid temperature range for standard sealing (NBR)	°C (°F)	-30 ... +100 (-22 ... 212)			
Fluid temperature range for Viton sealing (FPM)	°C (°F)	-20 ... +120 (-4 ... 248)			
Viscosity range	mm ² /s (SUS)	10 ... 500 (49 ... 2450)			
Max. degree of fluid contamination	Class 21/18/15 according to ISO 4406				
Weight	kg (lbs)	0.24 (0.53)			
Maximum valve tightening torque	Nm (lbf.ft)	35+5 (25.8+3.7 lbf.ft)			
Mounting position	unrestricted				
Valve body (data sheet HA 0018)	SB-B2				

p-Q Characteristics

Measured at $v = 32 \text{ mm}^2/\text{s}$ (156 SUS)

Pressure drops related to flow rate.

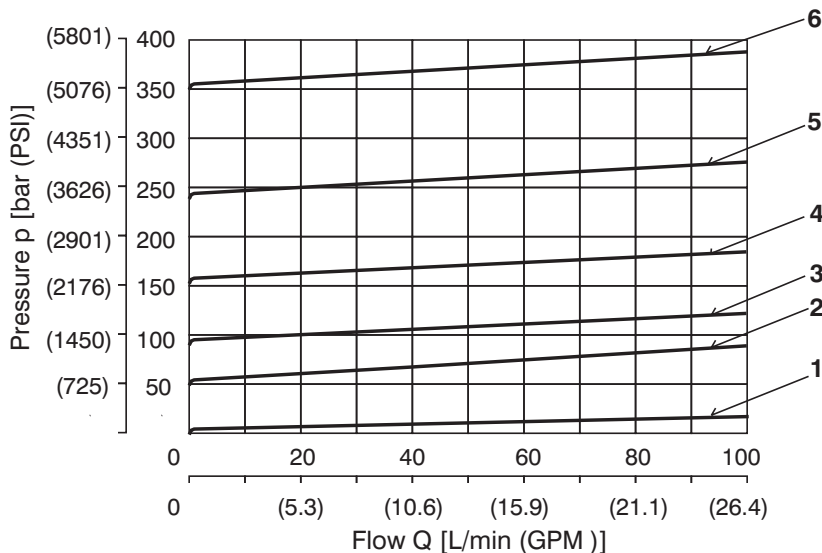

6	Pressure range 35
5	Pressure range 25
4	Pressure range 16
3	Pressure range 10
2	Pressure range 6,3
1	Min. pressure setting

Valve Dimensions

Dimensions in millimetres (inches)

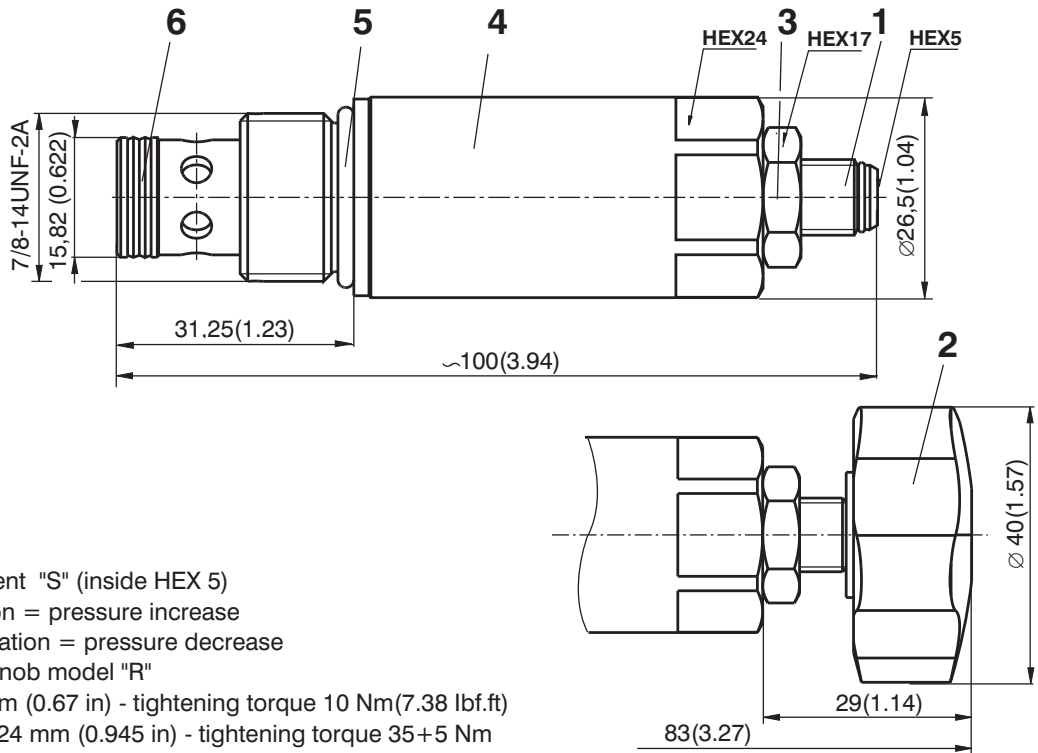

- 1 Adjustment element "S" (inside HEX 5)
Clockwise rotation = pressure increase
Anticlockwise rotation = pressure decrease
- 2 Adjustable handknob model "R"
- 3 Locknut s = 17mm (0.67 in) - tightening torque 10 Nm (7.38 lbf.ft)
- 4 Wrench flats s = 24 mm (0.945 in) - tightening torque 35+5 Nm (25.8+3.7 lbf.ft)
- 5 O-ring 19,4 x 2,1 (supplied with valve)
- 6 Combined sealing:
Dualseal DRYZ000002Z20 13,47x15,87x3,1 (supplied with valve)

Cavity

Dimensions in millimetres (inches)

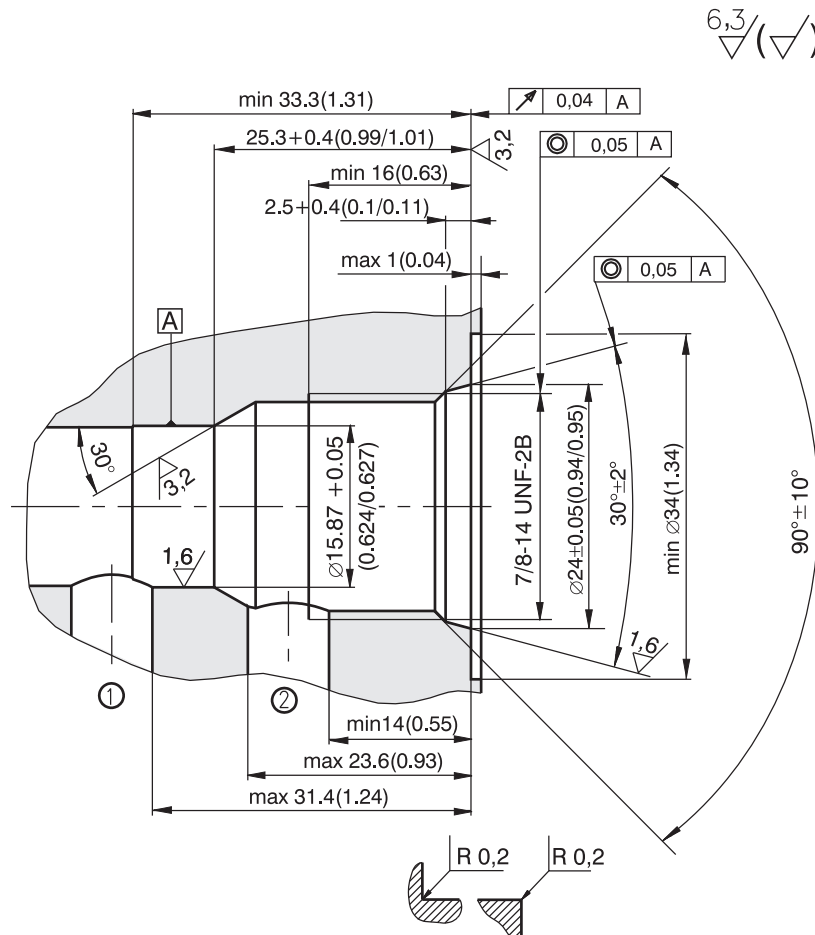

Spare Parts

Seal kit		Ordering number
Dualseal - PU	O-ring - NBR	18775600
DRYZ000002Z20 13,47 x 15,87 x 3,1 (1pc.)	19,4 x 2,1 (1pc.)	

3

Caution!

- The packing foil is recyclable.
- The technical information regarding the product presented in this catalogue is for descriptive purposes only. It should not be construed in any case as a guaranteed representation of the product properties in the sense of the law.

ARGO-HYTOS s.r.o. CZ - 543 15 Vrchlabí
 Tel.: +420-499-403 111
 E-mail: info.cz@argo-hytos.com
 www.argo-hytos.com

- Cartridge, modular and in-line design
- Five pressure ranges
- Two pressure adjustment options:
 - screw with internal hexagon
 - hand knob with arrestment

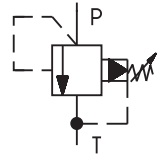

Functional Description

Pressure relief valves VPN1 are pilot operated pressure valves designed for system pressure limitation. The pressure adjustment provides the adjustment screw (4). In its basic state, the valve is closed. The pressure acts on the face area of the control spool (1) and at the same time through orifice (2) on the control spool rear side, which is preloaded by a spring and further on through orifice (3) on the pilot valve ball (6). When the increasing system pressure reaches the value, which is preset by spring (5), the valve opens and

the control flow passes through the pilot valves. The spool area which is preloaded by the spring becomes relieved, the spool control edge opens the radial bores in bushing (7) and the fluid passes from port P to T. The control flow is routed through groove (8) to channel T. Valve adjustment can be lockwired (9).

The valve body and the adjustment screw are zinc coated. With models M and R the valve bodies are phosphate coated.

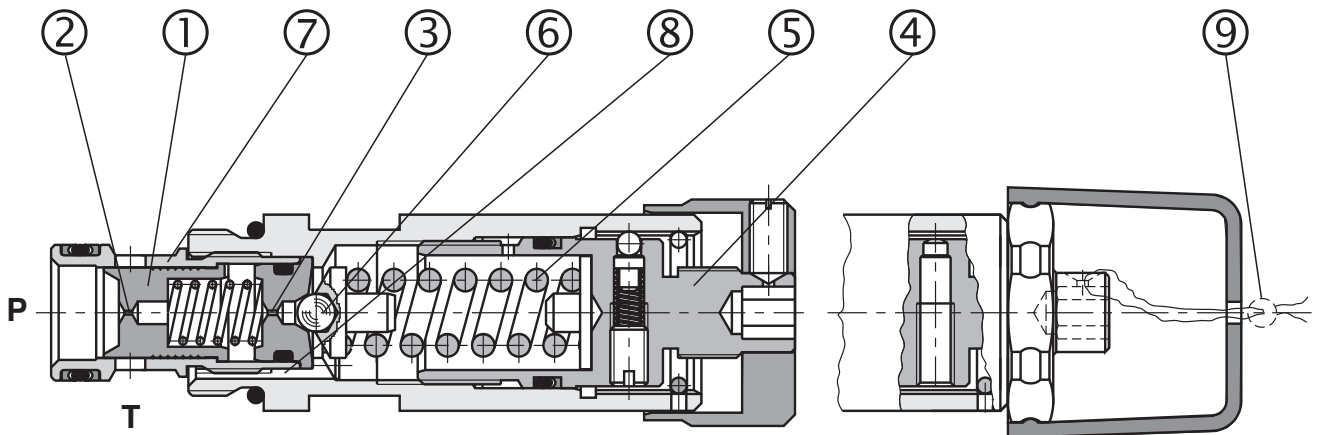

Ordering Code

VPN1-06/ -

Pilot Operated Pressure Relief Valve

Nominal size

Model

- screw in cartridge
- modular valve, flow from A to T
- modular valve, flow from B to T
- modular valve, flow from P to T
- modular valve, flow from A to B and B to A
- modular valve, flow from A and B to T
- in-line valve, thread G3/8
- in-line valve, thread G1/2
- in-line valve, thread G3/8
- in-line valve, thread G1/2

- S**
- MA**
- MB**
- MP**
- MC**
- MD**
- RA1**
- RA2**
- RB1**
- RB2**

without designation
V

Sealing
NBR
FPM (Viton)

S
R

Adjustment element
screw with internal hexagon
hand knob

Pressure range

- 6 up to 63 bar
- 10** up to 100 bar
- 16** up to 160 bar
- 21** up to 210 bar
- 32** up to 320 bar

FOR PREFERRED TYPES SEE BOLD TYPING IN ORDERING CODE AND TABLE OF PREFERRED TYPES ON PAGE 10

Functional Symbols

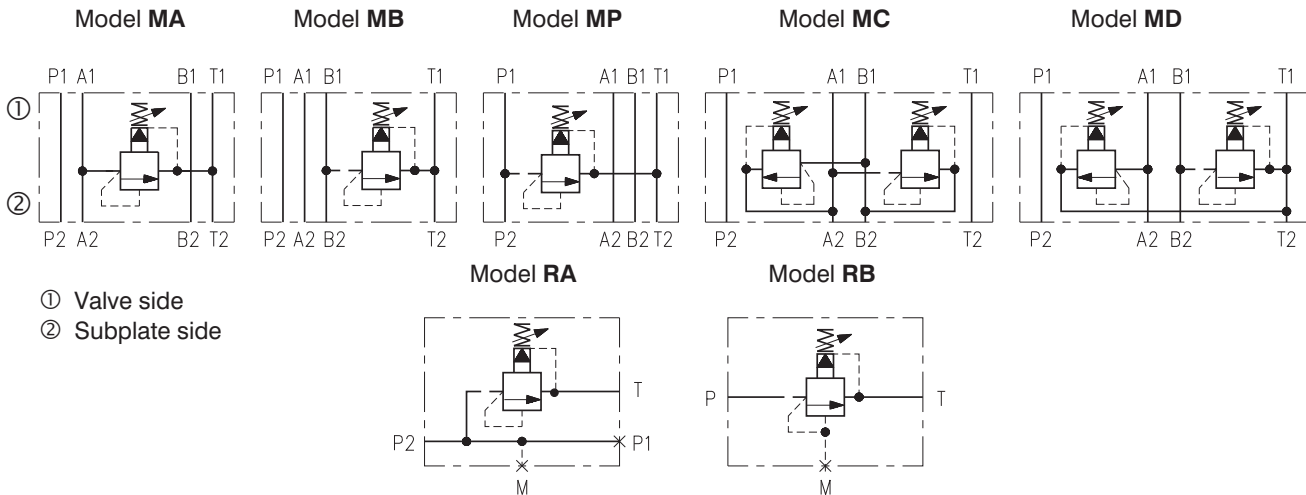

Ordering Numbers of Sandwich / Valve Bodies (without screw-in cartridge)

Valve body for modular valve - NBR	Ordering number	Valve body for modular valve - Viton	Ordering number
MA06-VP	15988600	MA06-VP/V	22949600
MB06-VP	15988800	MB06-VP/V	16661700
MP06-VP	15989000	MP06-VP/V	22949800
MC06-VP	15989200	MC06-VP/V	16758800
MD06-VP	15989300	MD06-VP/V	22950100
Valve body for in-line valve - NBR	Ordering number	Valve body for in-line valve - Viton	Ordering number
RA1-06-VP	15989800	RA3-06-VP/V	22939200
RA2-06-VP	15989900	RA4-06-VP/V	22939300
RB1-06-VP	15990000	RB3-06-VP/V	22939400
RB2-06-VP	15990100	RB4-06-VP/V	22939500

Technical Data

Nominal size	mm	06
Max. flow rate	L/min	70
Max. control flow	L/min	0.35
Max. service pressure ports (P, T, A, B)	bar	350
Working pressure related to flow	bar	see p-Q characteristics
Hydraulic fluid		Hydraulic oils of power classes (HL, HLP) to DIN 51524
Fluid temperature range for standard sealing (NBR)	°C	-30 ... +100
Fluid temperature range for Viton sealing (FPM)	°C	-20 ... +120
Viscosity range	mm ² /s	20 ... 400
Max. degree of fluid contamination		Class 21/18/15 according to ISO 4406
Weight	kg	0.25
Weight - models MA, MB, MP		1.2
- models MC, MD	kg	1.5
- models RA1, RA2, RB1, RB2		1.25
Mounting position		unrestricted

3

p-Q Characteristics for Model S

Measured at $v = 32 \text{ mm}^2/\text{s}$

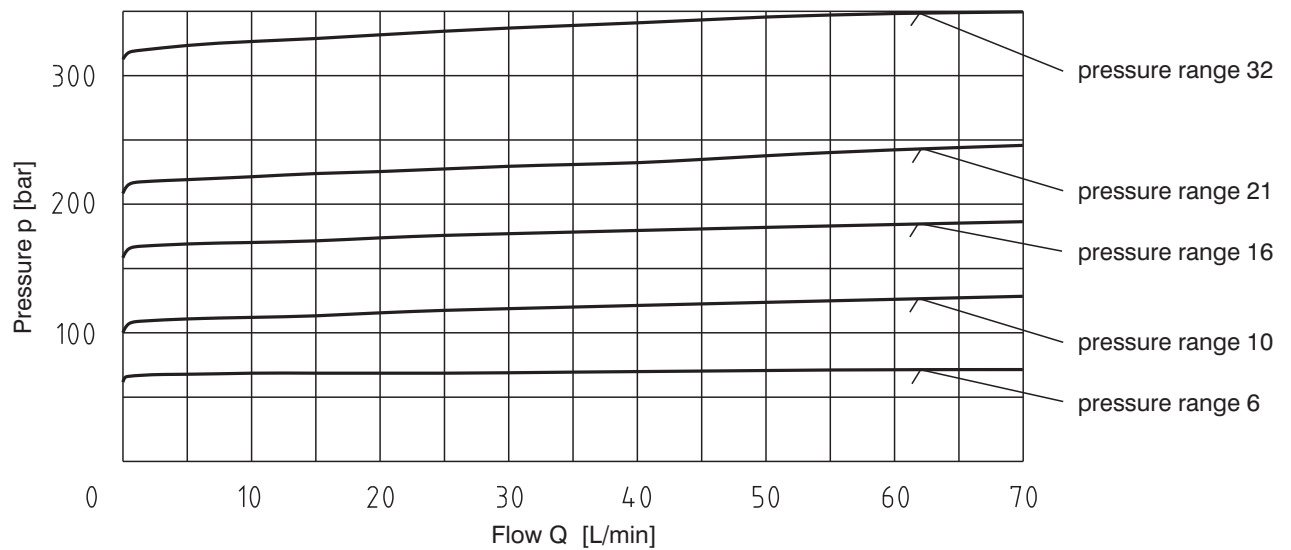

Δp -Q Characteristics

Measured at $v = 32 \text{ mm}^2/\text{s}$

Pressure drop Δp related to flow rate.

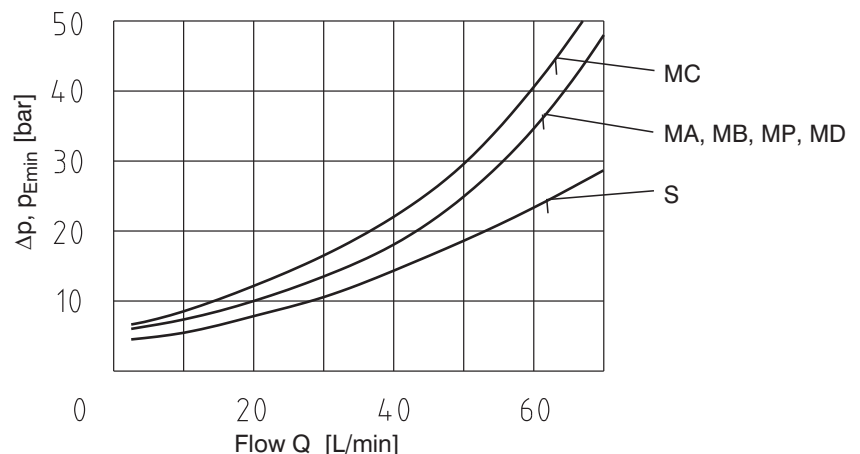

Valve Dimensions

Dimensions in millimetres

Model S

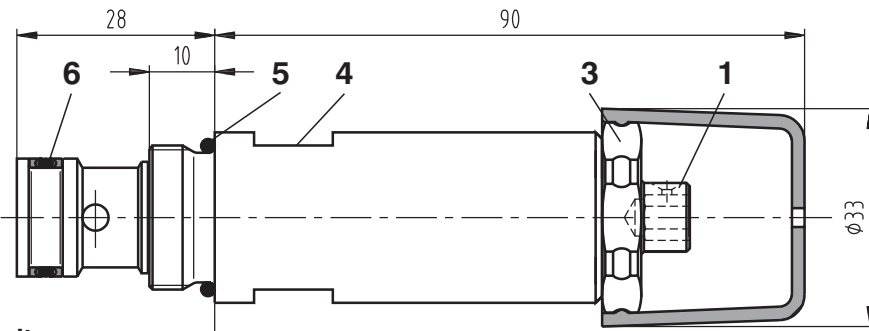

Cavity

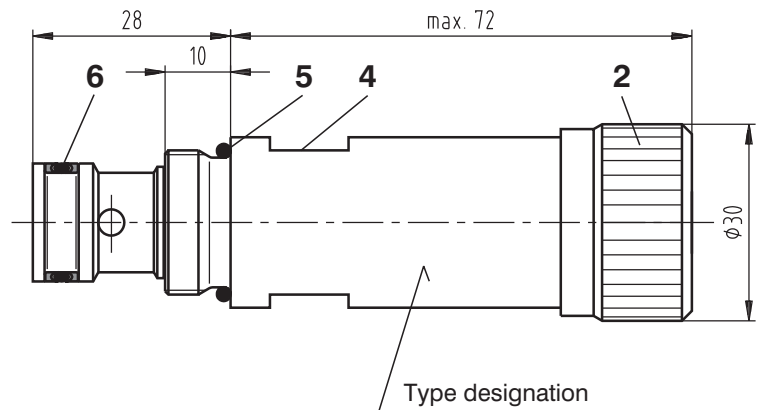
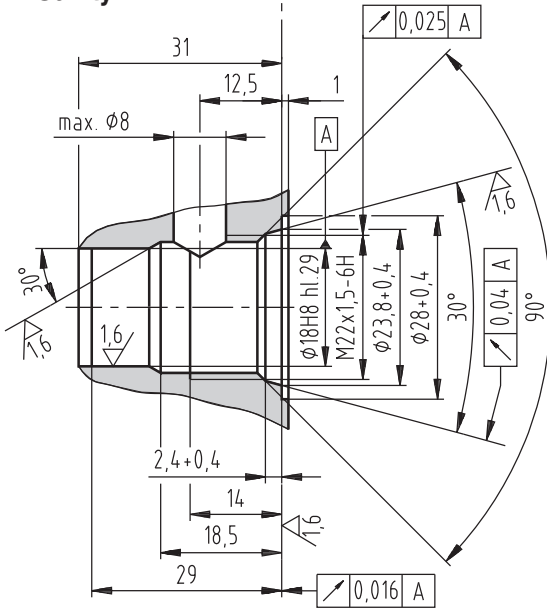

1 Adjustment element (screw with internal HEX 6)

2 Adjustment element R (hand knob)

With all adjustment elements:

- clockwise rotation - pressure increase
- anticlockwise rotation - pressure decrease

3 Locknut HEX 27

4 Wrench flats (s=24 mm) - tightening torque 30 Nm

5 O-ring 19.4 x 2.1 NBR 80 (1 pc.)

supplied with valve

6 Combined sealing:

O-ring 14 x 1.78 NBR 90 (1 pc.)

Back-up ring BBP80B015-N9 14.73 x 17.43 x 1.14 (2 pcs.)

supplied with valve

Valve Dimensions

Dimensions in millimetres

Model MA

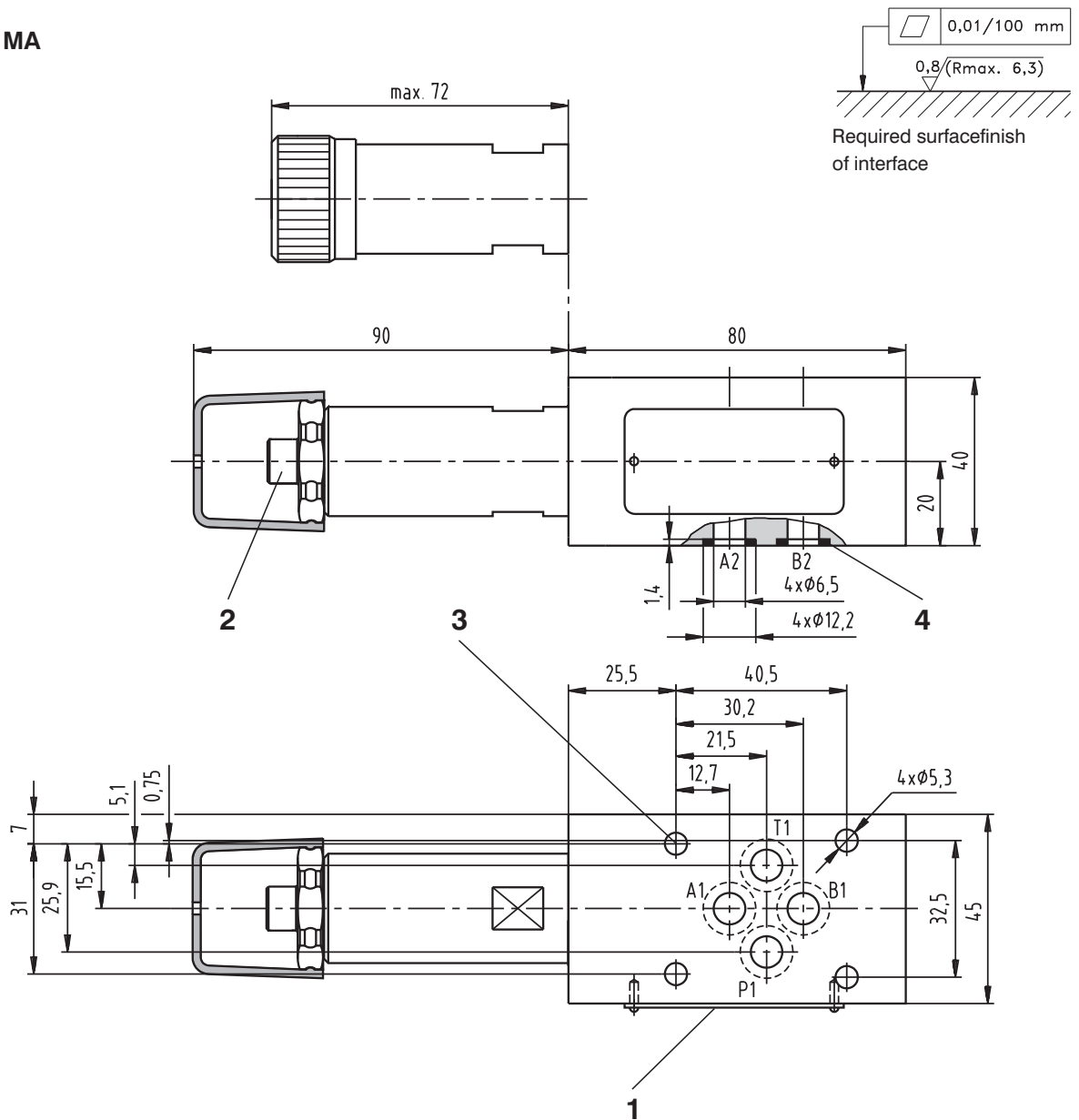

- 1 Name plate
- 2 Adjustment element for pressure setting
- 3 4 through mounting holes
- 4 Square rings 9.25 x 1.68 (4 pcs.) supplied with valve

3

Valve Dimensions

Dimensions in millimetres

Models MB and MP

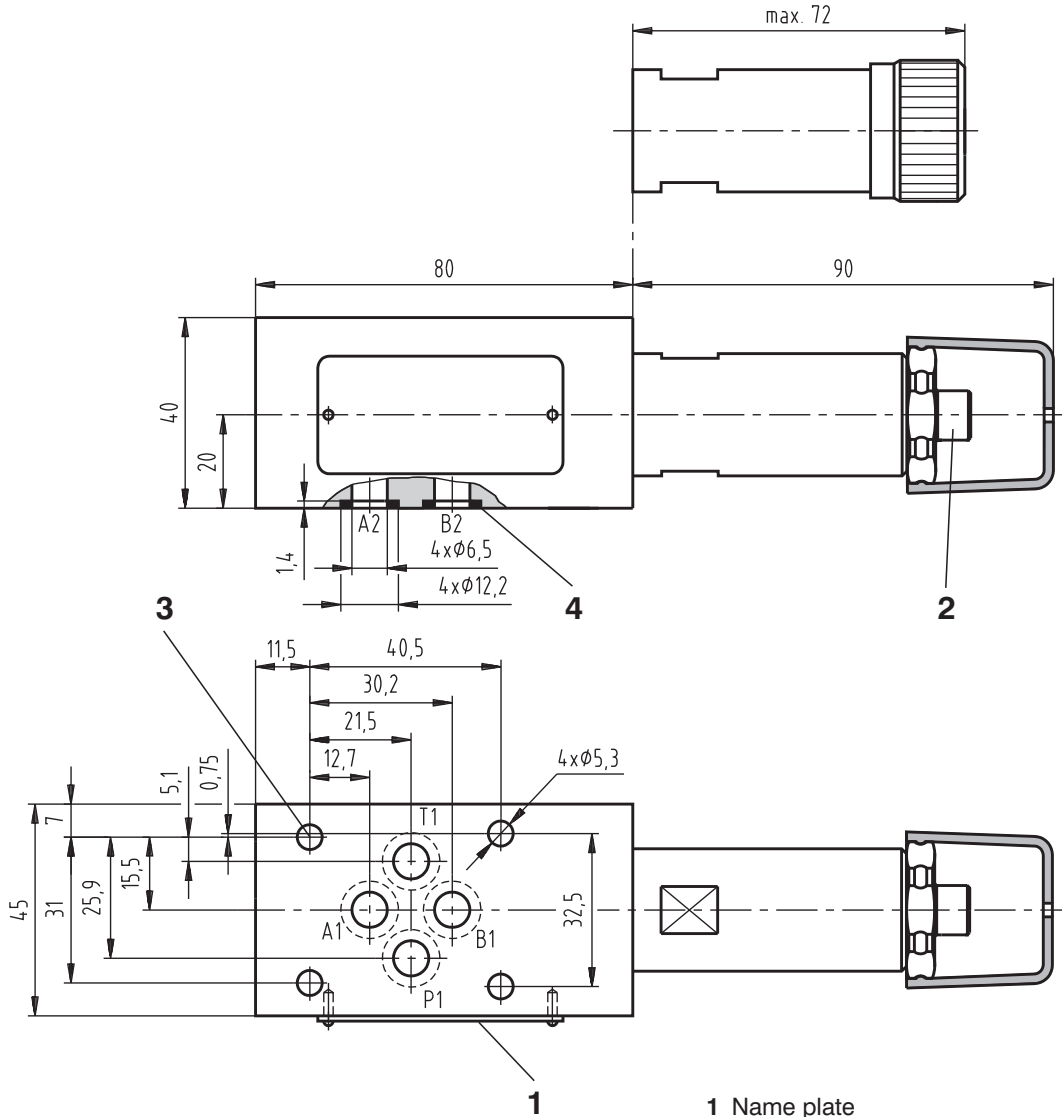
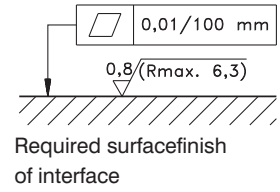

- 1 Name plate
- 2 Adjustment element for pressure setting
- 3 4 through mounting holes
- 4 Square rings 9.25 x 1.68 (4 pcs.) supplied with valve

3

Valve Dimensions

Dimensions in millimetres

Models MC and MD

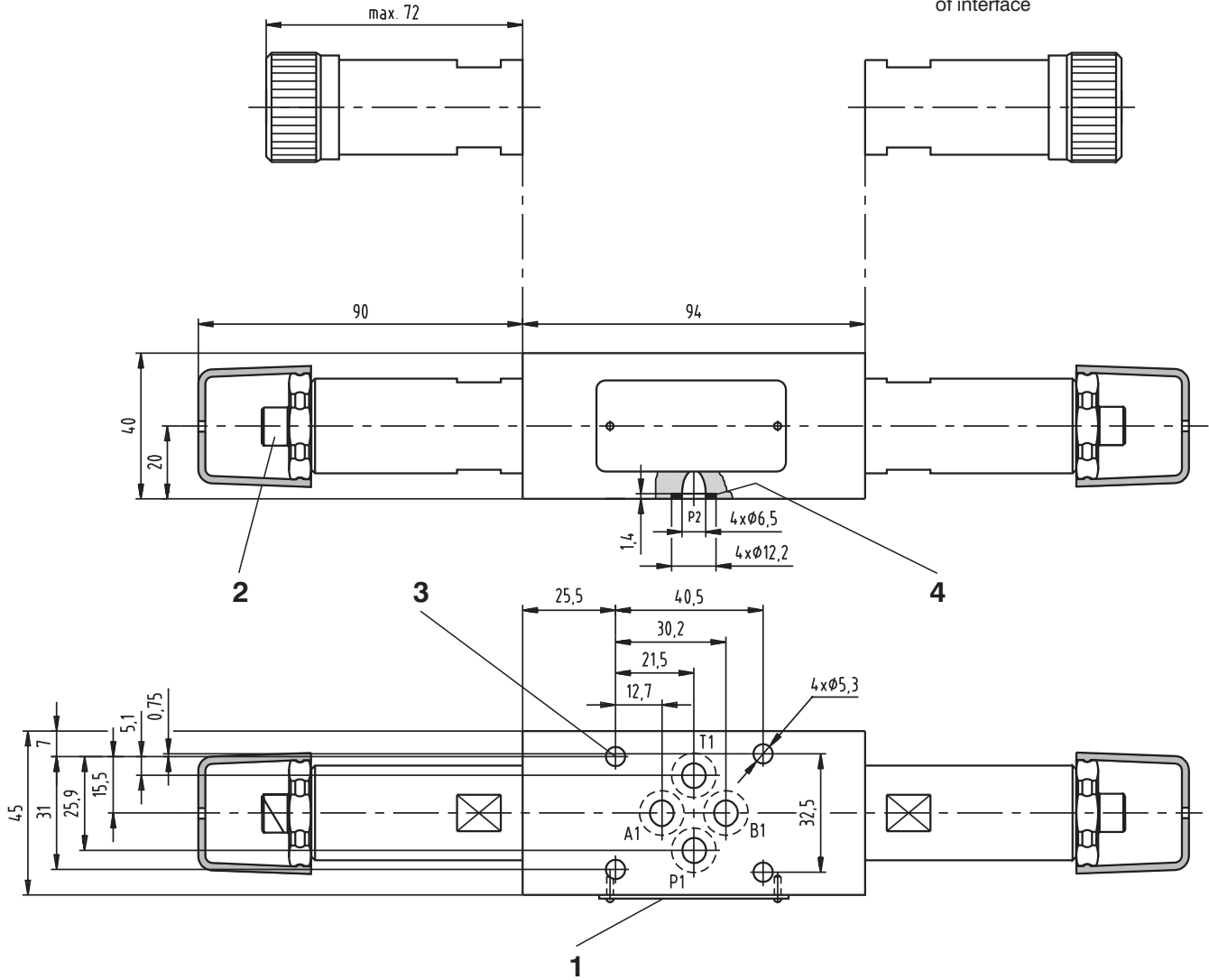
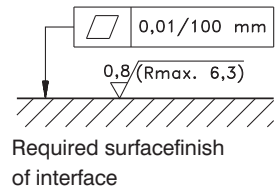

- 1 Name plate
- 2 Adjustment element for pressure setting
- 3 4 through mounting holes
- 4 Square rings 9.25 x 1.68 (4 pcs.) supplied with valve

Caution!

- The packing foil is recyclable.
- The protecting plate can be returned to the manufacturer.
- Mounting studs must be ordered separately. Tightening torque is 8.9 Nm.
- The technical information regarding the product presented in this catalogue is for descriptive purposes only. It should not be construed in any case as a guaranteed representation of the product properties in the sense of the law

Valve Dimensions

Dimensions in millimetres

Model RA1

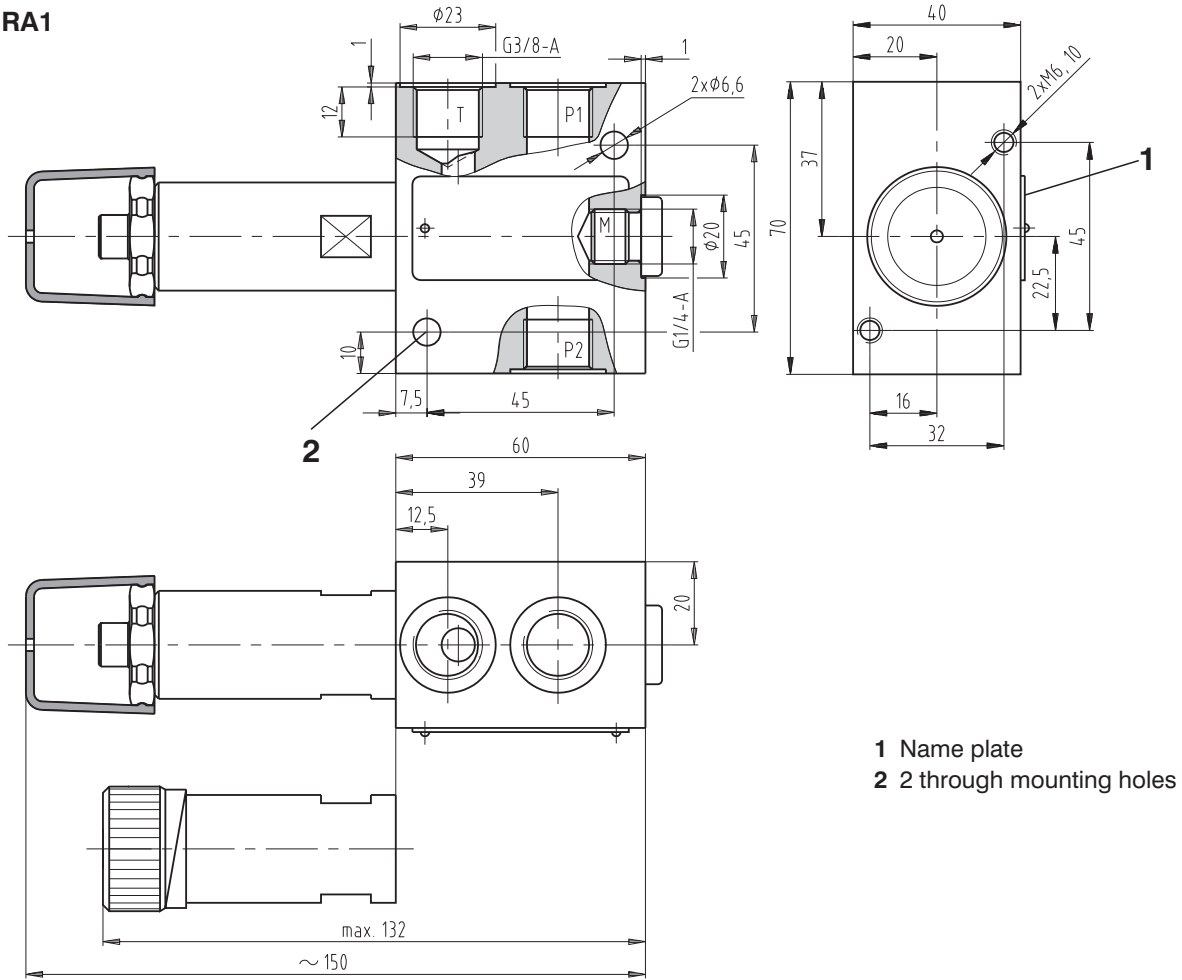

- 1 Name plate
- 2 2 through mounting holes

Model RA2

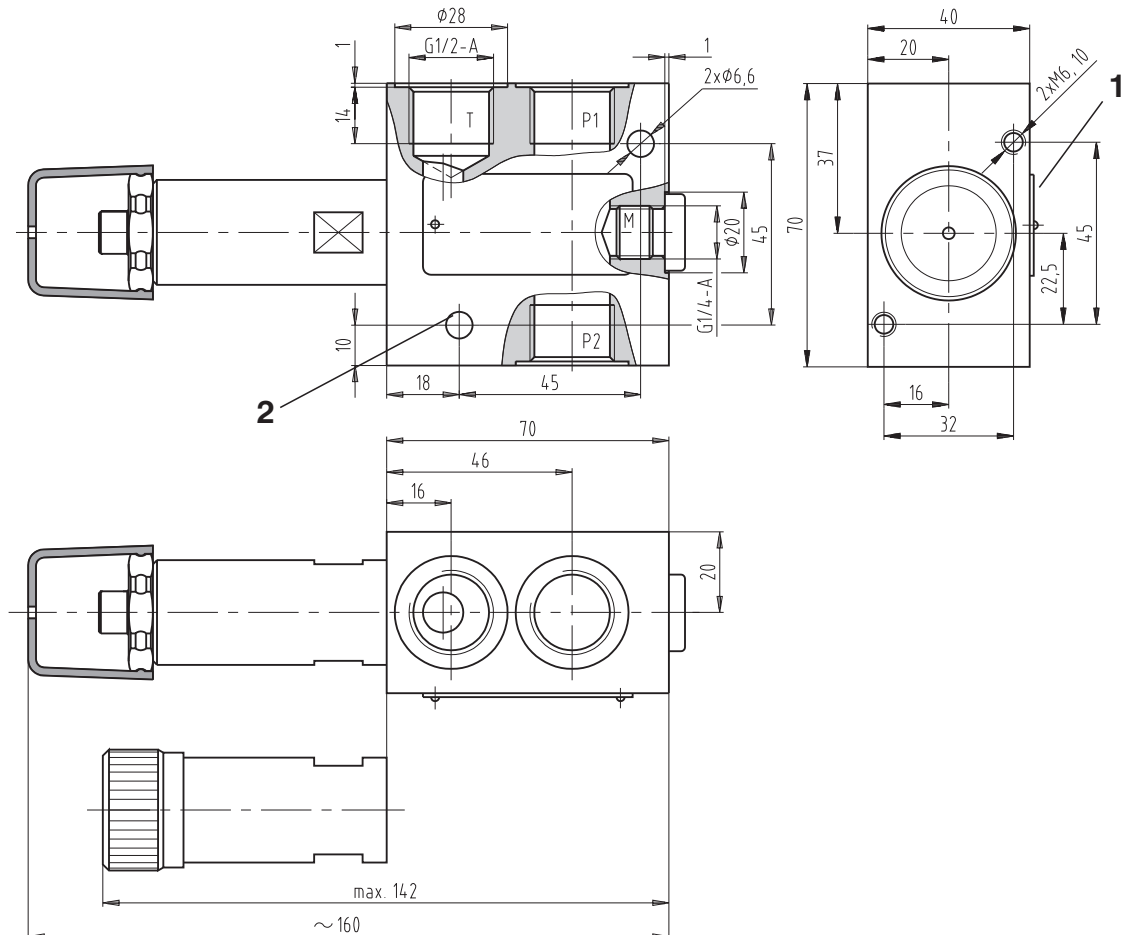

Spare Parts

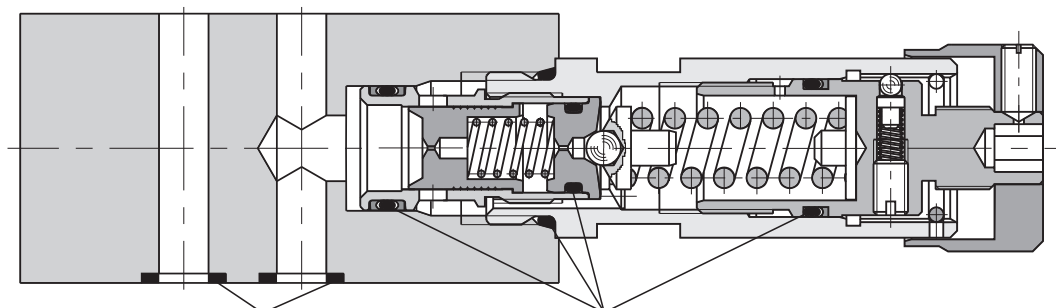

Set of the seals for modular valve

Set of the seals for screw-in cartridge

Model	Dimensions, number	Ordering number
Screw-in cartridge - NBR	O-ring 14 x 1.78 NBR 90 (1 pc.)	15991900
	O-ring 17 x 1.8 NBR 70 (1 pc.)	
	O-ring 19.4 x 2.1 NBR 80 (1 pc.)	
	O-ring 9.25 x 1.78 NBR 90 (1 pc.)	
	Back-up ring BBP80B015-N9 14.73 x 17.43 x 1.14 (2 pc.)	
	Back-up ring BBP80B016-N9 16.33 x 19.03 x 1.14 (1 pc.)	
Screw-in cartridge - Viton	O-ring 14 x 1.78 (1 pc.)	15991800
	O-ring 17 x 1.8 (1 pc.)	
	O-ring 19.4 x 2.1 (1 pc.)	
	O-ring 9.25 x 1.78 (1 pc.)	
	Back-up ring BBP80B015 14.73 x 17.43 x 1.14 (2 pc.)	
	Back-up ring BBP80B016 16.33 x 19.03 x 1.14 (1 pc.)	
Model	Dimensions, number	Ordering number
Modular valve - NBR	Square-Ring 9.25 x 1.68 (4 pcs.)	15991700
Modular valve - Viton	O-ring 9.25 x 1.78 (4 pcs.)	22944700
Model	Typ, number	Ordering number
In-line valve RA1 - NBR	VSTI R1/4-ED (1 pc.)	22944200
	VSTI R3/8-ED (1 pc.)	
In-line valve RA2 - NBR	VSTI R1/4-ED (1 pc.)	22944400
	VSTI R1/2-ED (1 pc.)	
In-line valve RB1 - NBR	VSTI R1/4-ED (1 pc.)	22944600
In-line valve RB2 - NBR		
In-line valve RA1 - Viton	VSTI R1/4-ED - Viton (1 pc.)	22944100
	VSTI R3/8-ED - Viton (1 pc.)	
In-line valve RA2 - Viton	VSTI R1/4-ED - Viton (1 pc.)	22944300
	VSTI R1/2-ED - Viton (1 pc.)	
In-line valve RB1 - Viton	VSTI R1/4-ED - Viton (1 pc.)	22944500
In-line valve RB2 - Viton		

Preferred Types of Valves

Type	Ordering number	Type	Ordering number
VPN1-06/S-10S	15987800	VPN1-06/MP-32S	15992800
VPN1-06/S-21S	15988000	VPN1-06/RA2-10S	22964100
VPN1-06/S-32S	15988100	VPN1-06/RA2-21S	22964300
VPN1-06/MP-10S	22947800	VPN1-06/RA2-32S	22964500
VPN1-06/MP-21S	15992600		

ARGO-HYTOS s.r.o. CZ - 543 15 Vrchlabí
 Tel.: +420-499-403111, Fax: +420-499-403421
 E-mail: sales.cz@argo-hytos.com
 www.argo-hytos.com

- Screw in cartridge design
- Five pressure ranges
- Two pressure adjustment options:
 - screw with internal hexagon
 - hand knob with arrestment
- Installation dimensions to ISO 4401 and DIN 24 340-A10

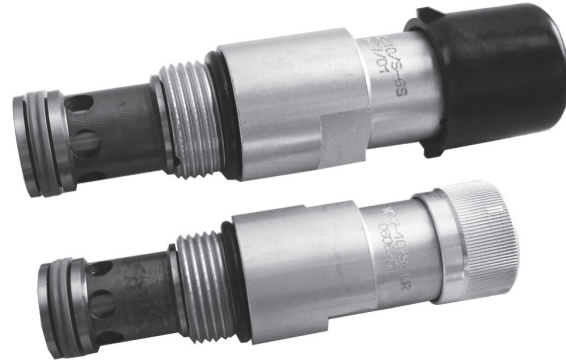
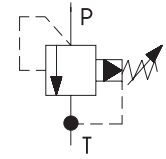

3

Functional Description

Pressure relief valves VPN2 are pilot operated pressure valves designed for system pressure limitation.

The pressure adjustment is controlled by the adjustment screw (4). In its basic state, the valve is closed. The pressure acts on the face area of the control spool (1) and at the same time through orifice (2) on the control spool rear side, which is preloaded by a spring and further on through orifice (3) on the pilot valve ball (6).

When the increasing system pressure reaches the value, which is preset by spring (5), the valve opens and the control flow passes through the pilot valve. The spool area which is preloaded by spring becomes relieved, the spool

control edge opens the radial bores in bushing (7) and the fluid passes from port P to T. The control flow is routed through slot (8) to port T.

When an accurate pressure control, which does not depend on pressure variations in port T, is required, the model "Y" with external port for pilot flow is to be used.

If a relieving of the valve on a lower pressure as that set up by the spring (5) is needed, the model with port "X" (10) is to be used.

The basic surface treatment of the valve body and the adjustment screw are zinc coated.

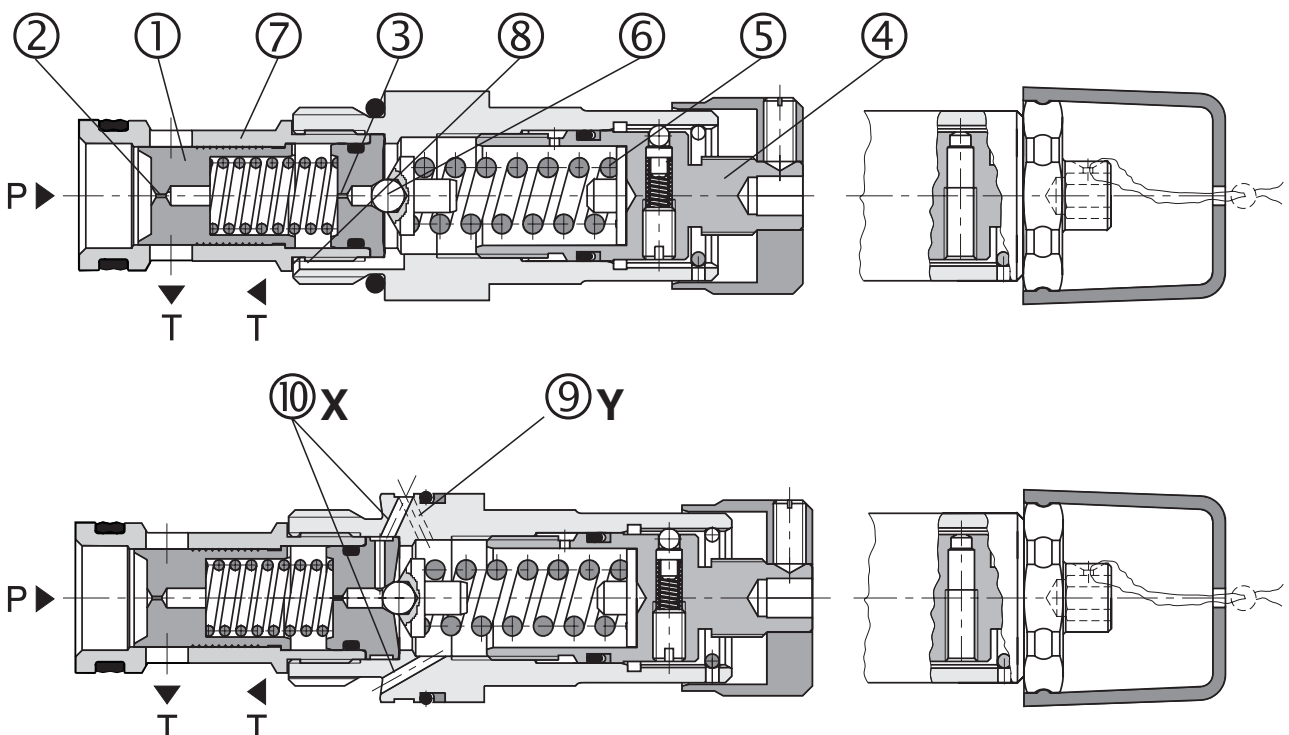

Ordering Code

VPN2-10/ -

Pilot Operated Pressure Relief Valve

Seals
 without designation NBR
 V FPM (Viton)

Nominal size

Adjustment element
 S screw with internal hexagon
 R hand knob

Model
 screw in cartridge - internally piloted, internally drained **S**
 screw in cartridge - externally piloted, internally drained **SX**
 screw in cartridge - internally piloted, externally drained **SY**

Pressure range
 6 up to 63 bar
 10 up to 100 bar
 16 up to 160 bar
 21 up to 210 bar
 32 up to 350 bar

Functional Symbols

Model X

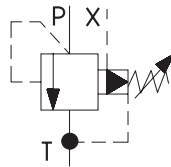

Model Y

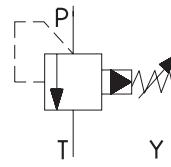

Technical Data

Nominal size	mm	10
Max. flow rate	L/min	150
Max. control flow	L/min	0,5
Max. service pressure ports (P, T, X, Y)	bar	350
Working pressure related to flow	bar	see p-Q Characteristics
Hydraulic fluid		Hydraulic oils of power classes (HL, HLP) to DIN 51524
Fluid temperature range for standard sealing (NBR)	°C	-30 ... +100
Fluid temperature range for Viton sealing (FPM)	°C	-20 ... +120
Viscosity range	mm ² /s	20 ... 400
Max. degree of fluid contamination		Class 21/18/15 according to ISO 4406
Weight	kg	0.3
Mounting position		unrestricted

3

p-Q Characteristics

Measured at $v = 32 \text{ mm}^2/\text{s}$

Model S, SX

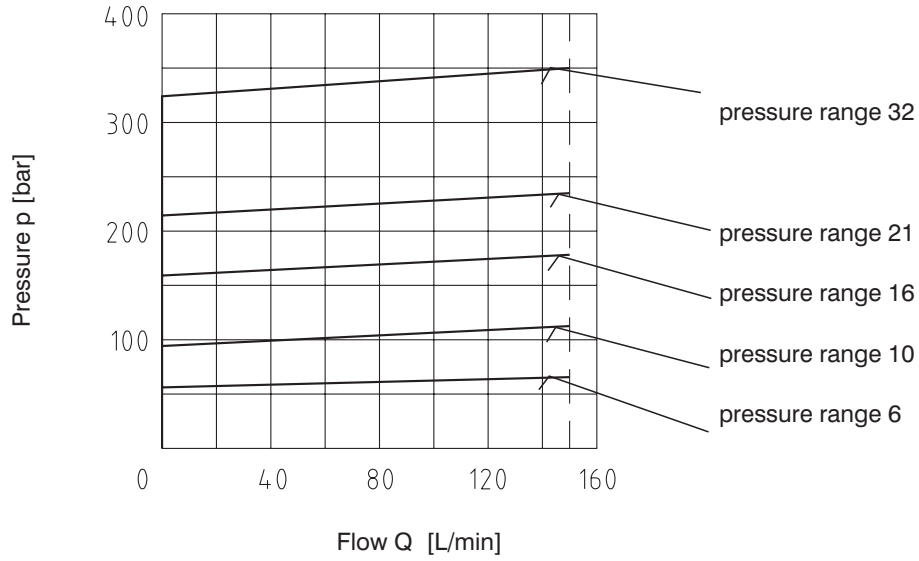

p-Q Characteristics

Measured at $v = 32 \text{ mm}^2/\text{s}$

Model SY

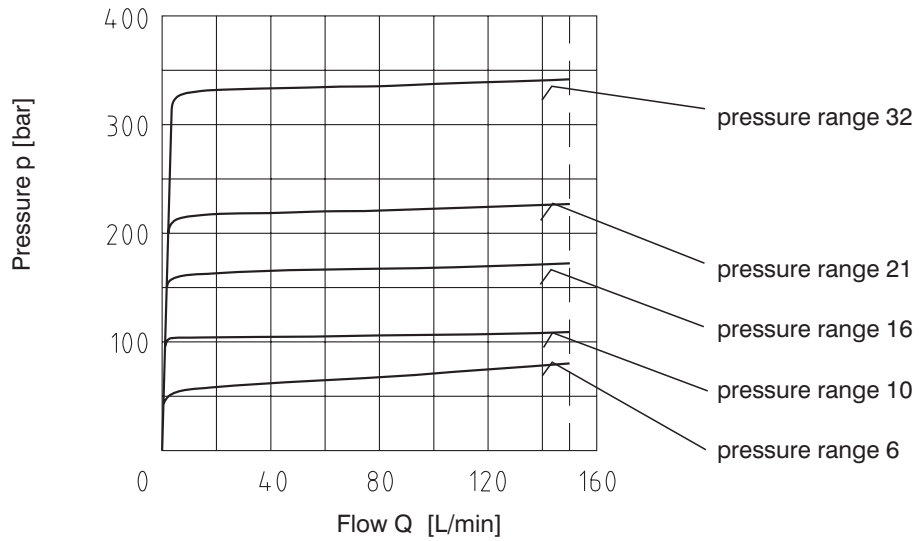

Δp -Q Characteristics

Measured at $n = 32 \text{ mm}^2/\text{s}$

Model S, SX, SY

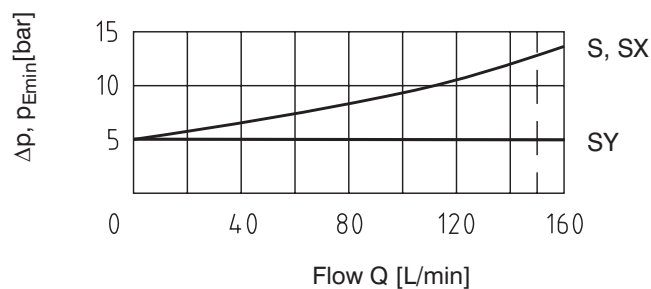

3

Valve Dimensions

Dimensions millimetres

Model S

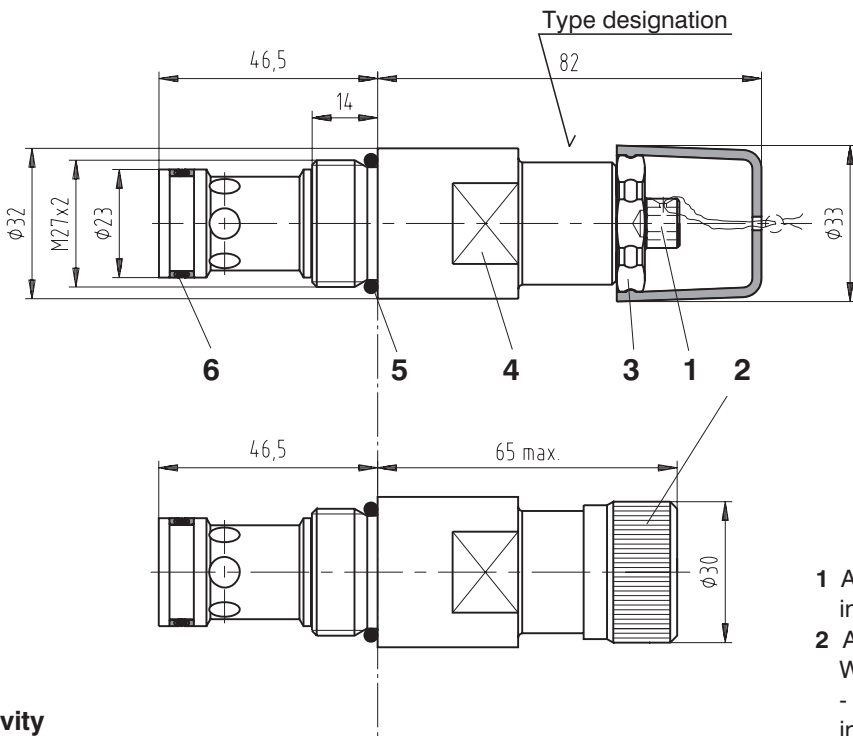

- 1 Adjustment element (screw with internal HEX 6)
- 2 Adjustment element R (hand knob)
 With all adjustment elements:
 - clockwise rotation - pressure increase
 - anticlockwise rotation - pressure decrease
- 3 Locknut HEX 27
- 4 Wrench flats s= 27
 - tightening torque 60 Nm
- 5 O-ring 23.47 x 2.62 NBR 70 (1 pc.)
 supplied with each valve
- 6 DUAL DU0100230-Z20
 19,6 x 23 x 4,4 (1 pcs.)
 supplied with each valve

Cavity

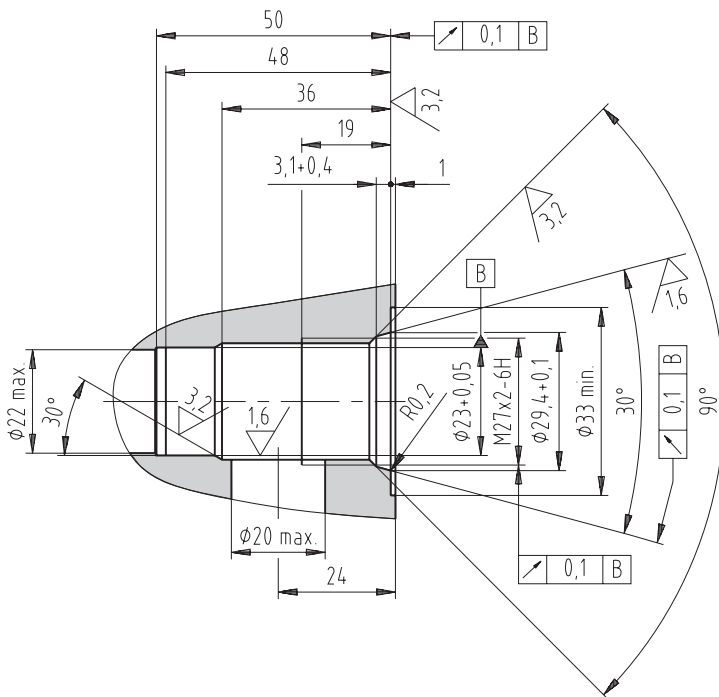

Valve Dimensions

Dimensions millimetres

Model SX, SY

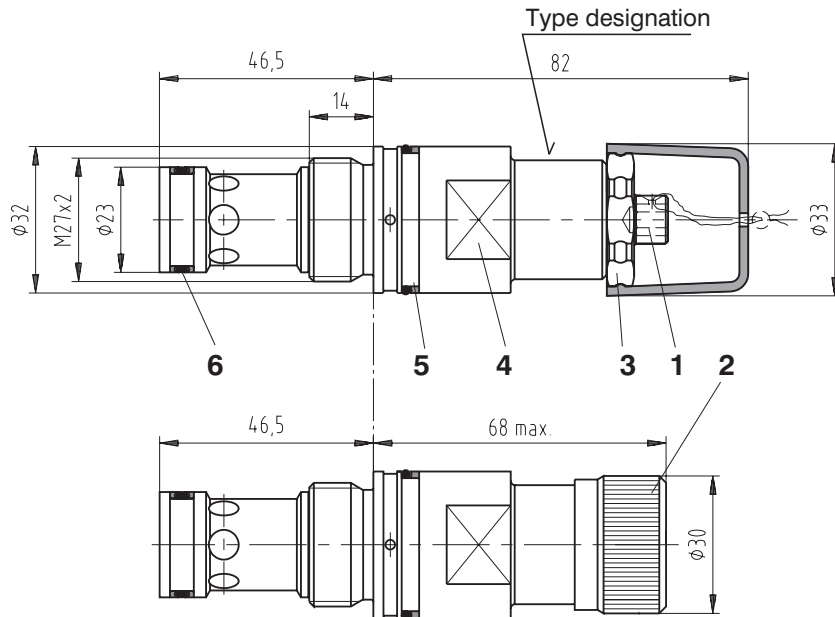

Cavity

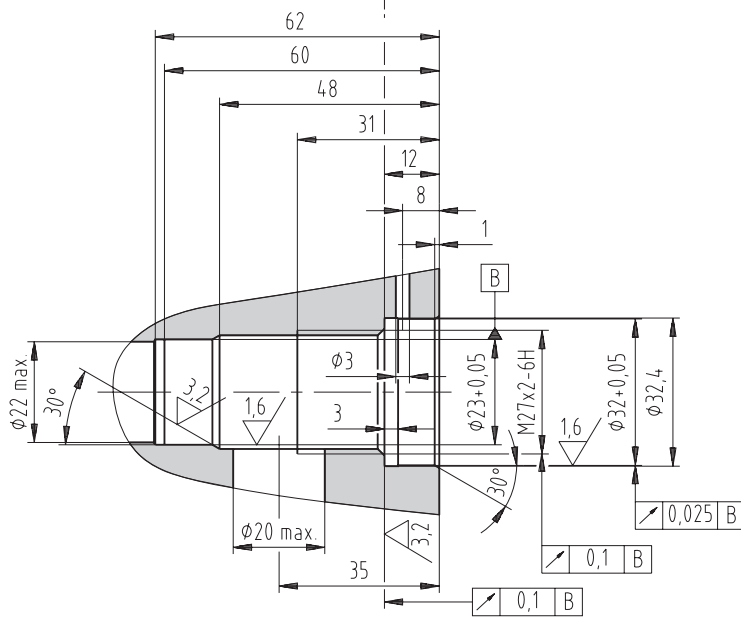

- 1 Adjustment element (screw with internal HEX 6)
- 2 Adjustment element R (hand knob)
With all adjustment elements:
- clockwise rotation - pressure increase
- anticlockwise rotation - pressure decrease
- 3 Locknut HEX 27
- 4 Wrench flats s=27
- tightening torque 60 Nm
- 5 Combined sealing:
O-ring 28.3 x 1.78 (1 pc.)
Back-up ring BBP80B024
29.03 x 31.73 x 1.14 (1 pc.)
supplied with each valve
- 6 Combined sealing:
DUAL DU0100230-Z20
19,6 x 23 x 4,4 (1 pcs.)
supplied with each valve

Spare Parts

Model	Dimensions, number	Ordering number
S - NBR	O-ring 23.47 x 2.95 NBR 90 (1 pc.)	15991500
	DUAL DU0100230-Z20 19,6 x 23 x 4,4 (1 pcs.)	
S - Viton	O-ring 23.47 x 2.95 V 90 (1 pc.)	22943400
	DUAL DU0100230-Z20 19,6 x 23 x 4,4 (1 pcs.)	
Model	Dimensions, number	Ordering number
SX, SY - NBR	O-ring 28.3 x 1.78 NBR 90 (1 pc.)	22943500
	DUAL DU0100230-Z20 19,6 x 23 x 4,4 (1 pcs.)	
	Back-up ring BBP80B024 29.03 x 31.73 x 1.14 (1 pc.)	
SX, SZ - Viton	O-ring 28.3 x 1.78 V 80 (1 pc.)	22943600
	DUAL DU0100230-Z20 19,6 x 23 x 4,4 (1 pcs.)	
	Back-up ring BBP80B024-V96 29.03 x 31.73 x 1.14 (1 pc.)	

Caution!

- The packing foil is recyclable.
- The technical information regarding the product presented in this catalogue is for descriptive purposes only. It should not be construed in any case as a guaranteed representation of the product properties in the sense of the law.

ARGO-HYTOS s.r.o. CZ - 543 15 Vrchlabí
 Tel.: +420-499-403111, Fax: +420-499-403421
 E-mail: sales.cz@argo-hytos.com
 www.argo-hytos.com

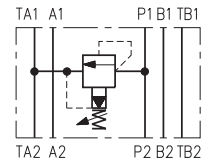

- Modular and in-line design
- Five pressure ranges
- Two pressure adjustment options:
 - screw with internal hexagon
 - hand knob with arrestment
- Installation dimensions to ISO 4401 and DIN 24 340-A10

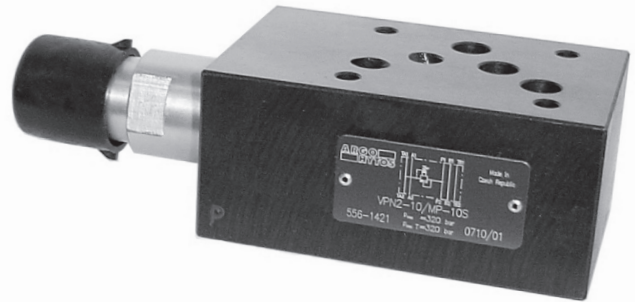

Functional Description

Pressure relief valves VPN2 are pilot operated pressure valves designed for system pressure limitation. The pressure adjustment is controlled by the adjustment screw (4). In its basic state, the valve is closed. The pressure acts on the face area of the control spool (1) and at the same time through orifice (2) on the control spool rear side, which is preloaded by a spring and further on through orifice (3) on the pilot valve ball (6). When the increasing system pressure reaches the value, which is preset by spring (5), the valve opens and the control flow passes through the pilot valve. The spool area which is preloaded by spring becomes relieved, the spool control edge opens the radial bores in bushing (7)

and the fluid passes from port B to T. The control flow is routed through slot (8) to port T. When an accurate pressure control, which does not depend on pressure variations in port T (only for models RC2 and RC3, see Functional Symbols), is required the model "Y" with external port for pilot flow is to be used. If a relieving of the valve on a lower pressure as that set up by the spring (5) is needed, the model with port "X" is to be used. The valve body and the adjustment screw are zinc coated. With models M and R the valve bodies are phosphate coated.

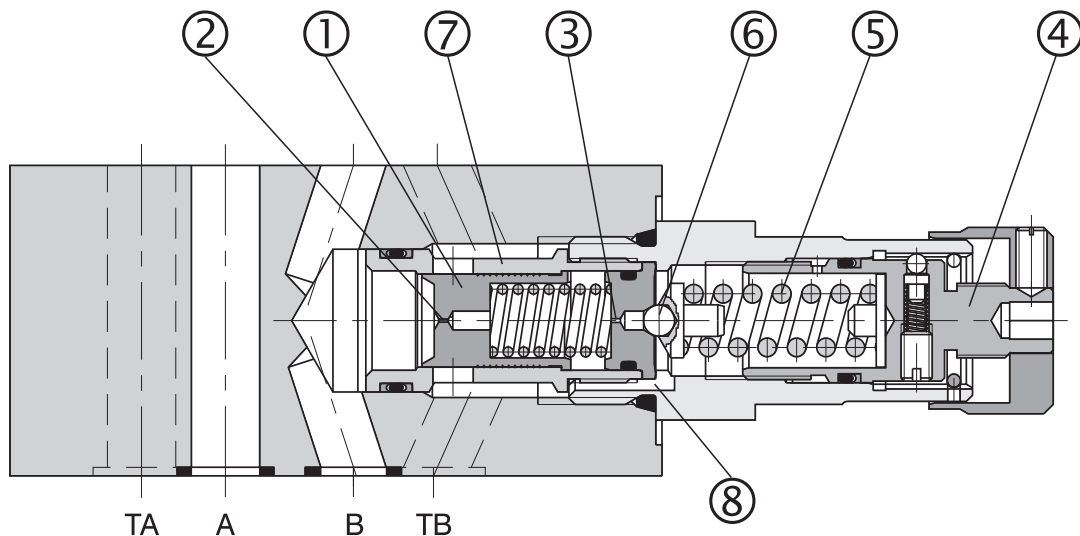

Ordering Code

VPN2-10/ -

Pilot Operated Pressure Relief Valve

Nominal size

Model

- modular valve, flow from A to TA **MA**
- modular valve, flow from B to TB **MB**
- modular valve, flow from P to TA **MP**
- modular valve, flow from A to B and B to A **MC**
- modular valve, flow from A to TA and B to TB **MD**
- in-line valve, thread P1, P2 - G3/4; T - G1 **RA2**
- in-line valve, thread P - G3/4; T - G1 **RB2**
- in-line valve, thread P - G3/4; T - G1; X - G1/4 **RC2**
- in-line valve, thread P - G3/4; T - G1; Y - G1/4 **RC3**

Seals
 without designation NBR
 V FPM (Viton)

Adjustment element
 S screw with internal hexagon
 R hand knob

Pressure range
 6 up to 63 bar (913 PSI)
 10 up to 1450 100 bar (1450 PSI)
 16 up to 160 bar (2321 PSI)
 21 up to 210 bar (3045 PSI)
 32 up to 350 bar (5076 PSI)

Model with two pressure relief cartridges
 32/10 pressure setting 350 bar (5076 PSI)
 in port A and 100 bar (1450 PSI) in port B, etc.

Functional Symbols

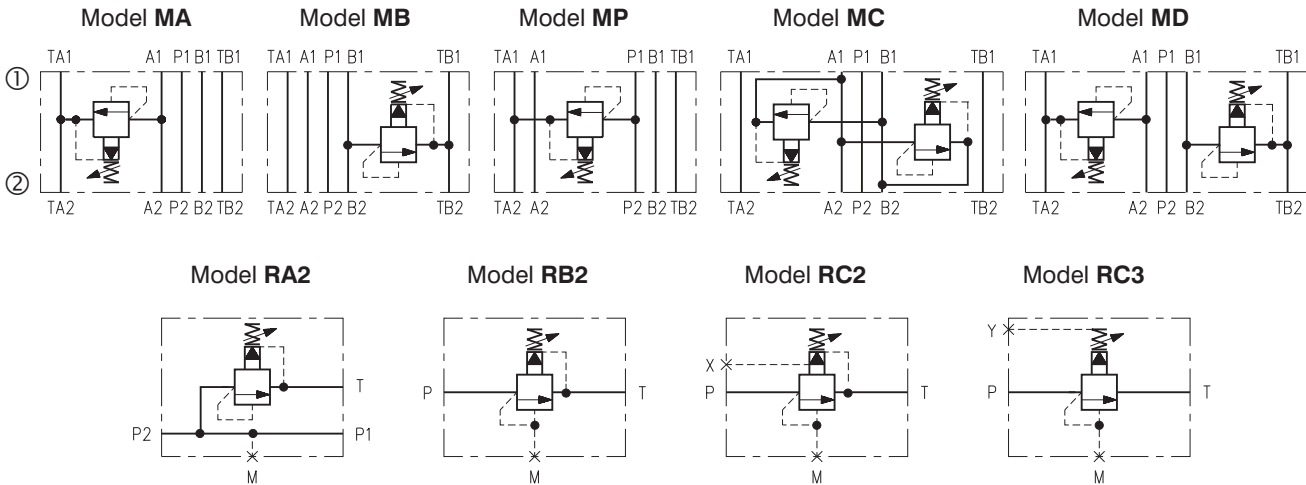

- ① Valve side
- ② Subplate side

Ordering Numbers of Sandwich / Valve Bodies (without screw-in cartridge)

Valve body for modular valve - NBR	Ordering number	Valve body for modular valve - Viton	Ordering number
MA10-VP	15995800	MA10-VP/V	22975100
MB10-VP	15995900	MB10-VP/V	22975200
MP10-VP	15996000	MP10-VP/V	22975300
MC10-VP	15996100	MC10-VP/V	22975400
MD10-VP	15996200	MD10-VP/V	22975500
Valve body for in-line valve - NBR	Ordering number	Valve body for in-line valve - Viton	Ordering number
RA2-10-VP	15996500	RA2-10-VP/V	22976600
RB2-10-VP	15996300	RB2-10-VP/V	22976300
RC2-10-VP (RC3-10-VP)	15996400	RC2-10-VP/V (RC3-10-VP/V)	22976400

Technical Data

Nominal size	mm	10
Max. flow rate	L/min	150
Max. control flow	L/min	0,5
Max. service pressure ports (P, T, A, B)	bar	350
Working pressure related to flow	bar	see p-Q characteristics
Hydraulic fluid		Hydraulic oils of power classes (HL, HLP) to DIN 51524
Fluid temperature range for standard sealing (NBR)	°C	-30 ... +100
Fluid temperature range for Viton sealing (FPM)	°C	-20 ... +120
Viscosity range	mm ² /s	20 ... 400
Max. degree of fluid contamination		Class 21/18/15 according to ISO 4406
Weight - models MA, MB, MP - models MC, MD - models RA2, RB2, RC2, RC3	kg	2,6 3,0 2,7
Mounting position		unrestricted

3

p-Q Characteristics

Measured at $v = 32 \text{ mm}^2/\text{s}$

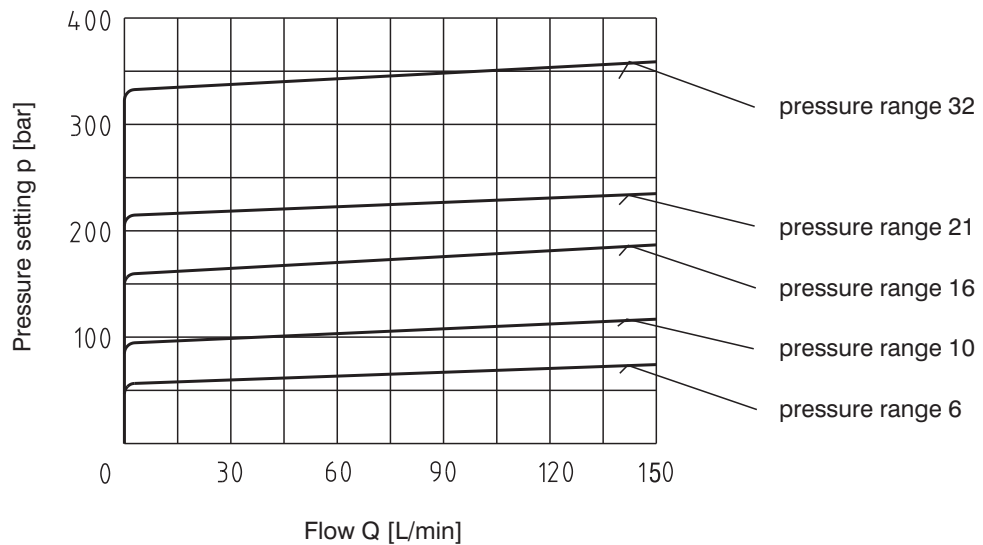

Δp-Q Characteristics

Measured at $v = 32 \text{ mm}^2/\text{s}$

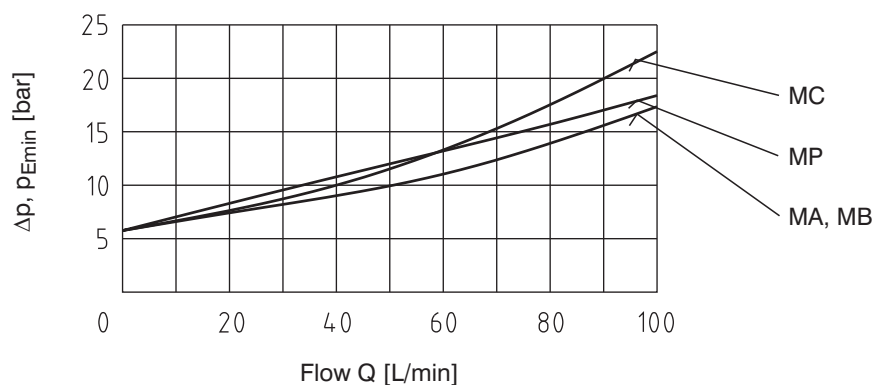

Valve Dimensions

Dimensions in millimetres

Model MA

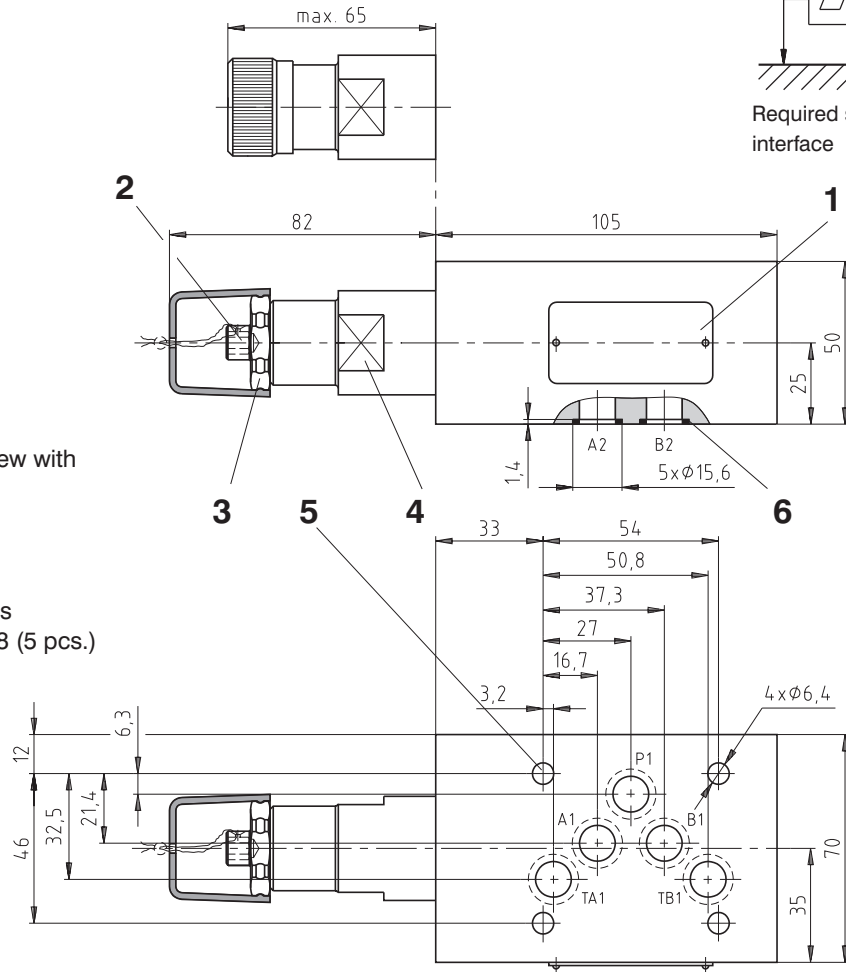
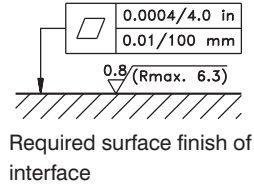

- 1 Name plate
- 2 Adjustment element (screw with internal HEX 6)
- 3 Locknut HEX 27
- 4 Wrench flats $s = 27$
- tightening torque 60Nm
- 5 4 through mounting holes
- 6 Square rings 12.42 x 1.68 (5 pcs.)
supplied with each valve

Model MB

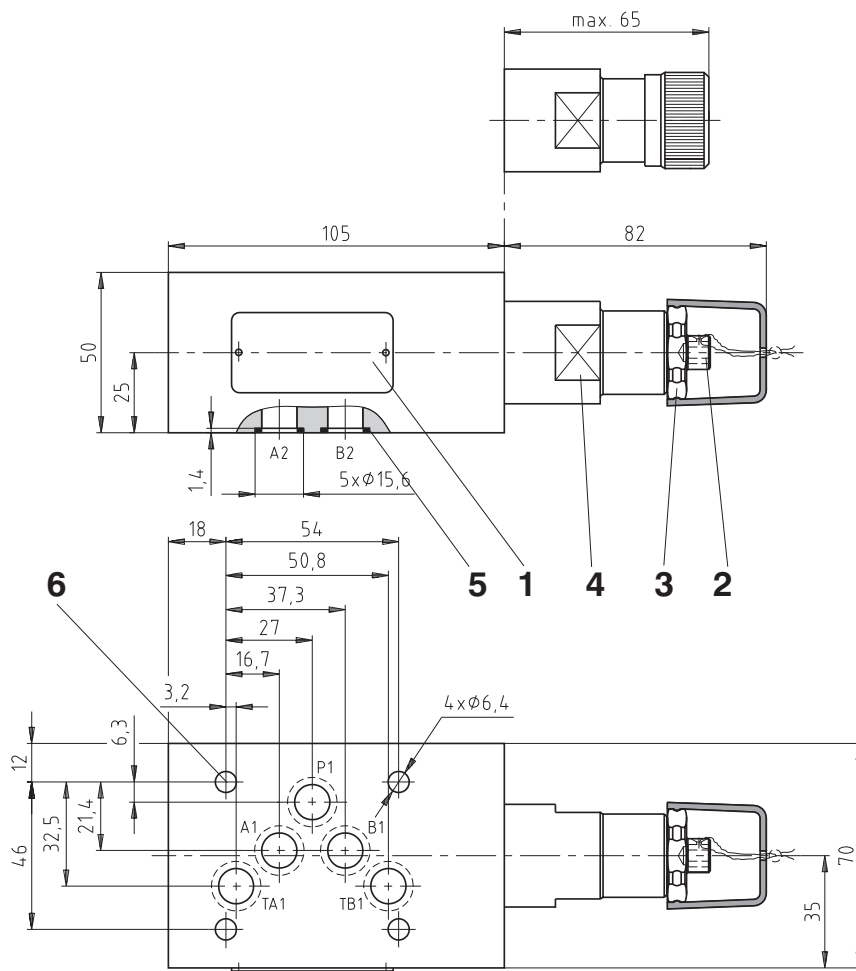

Valve Dimensions

Dimensions in millimetres

Model MP

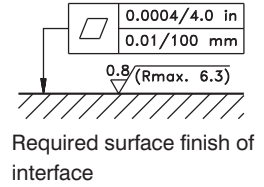

- 1** Name plate
- 2** Adjustment element (screw with internal HEX 6)
- 3** Locknut HEX 27
- 4** Wrench flats $s=27$
- tightening torque 60Nm
- 5** 4 through mounting holes
- 6** Square rings 12,42 x 1,68 (5 pcs.)
supplied with each valve

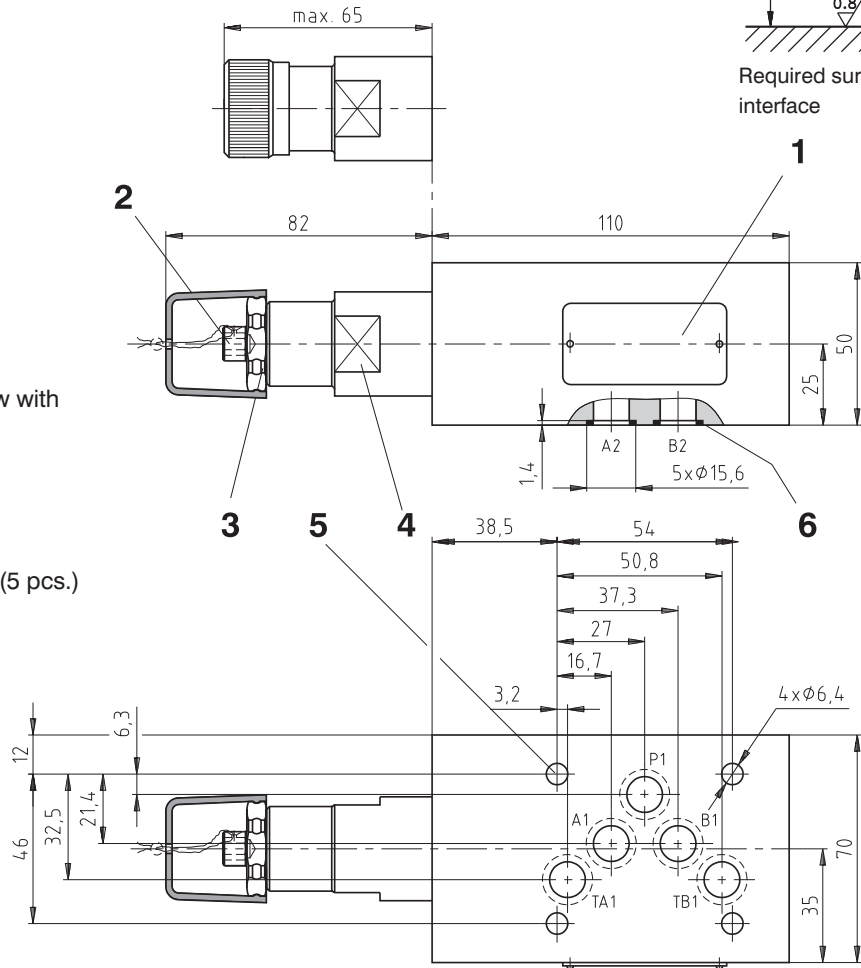

Models MC, MD

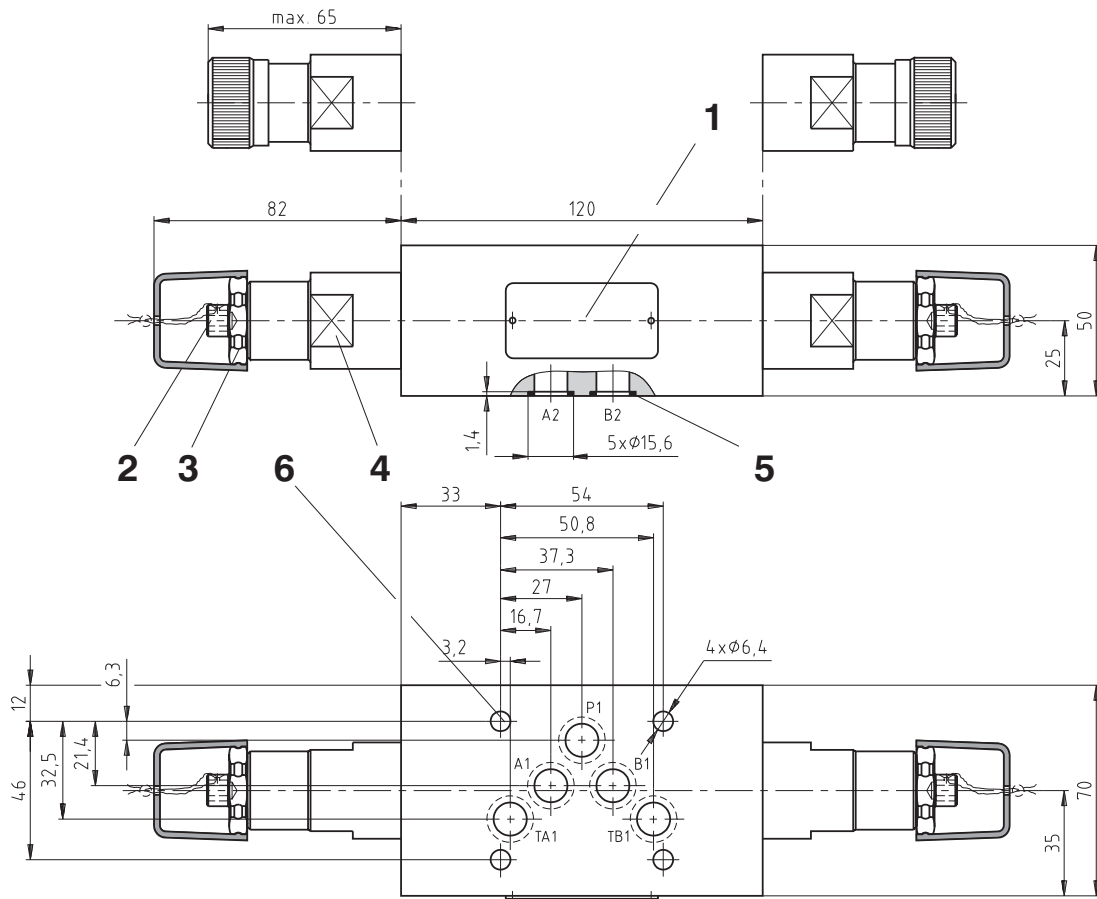

Valve Dimensions

Dimensions in millimetres

Model RA2

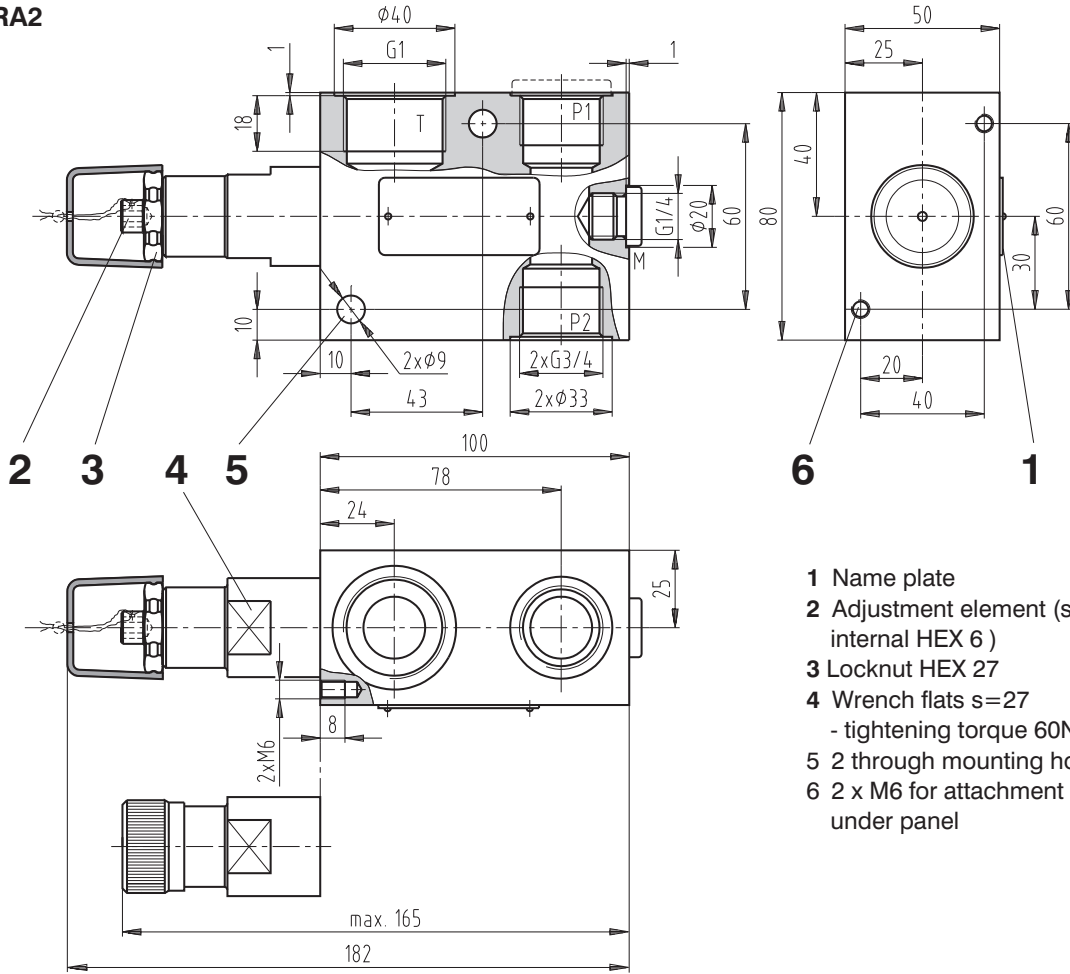

- 1 Name plate
- 2 Adjustment element (screw with internal HEX 6)
- 3 Locknut HEX 27
- 4 Wrench flats s=27
- tightening torque 60Nm
- 5 2 through mounting holes
- 6 2 x M6 for attachment under panel

Model RB2

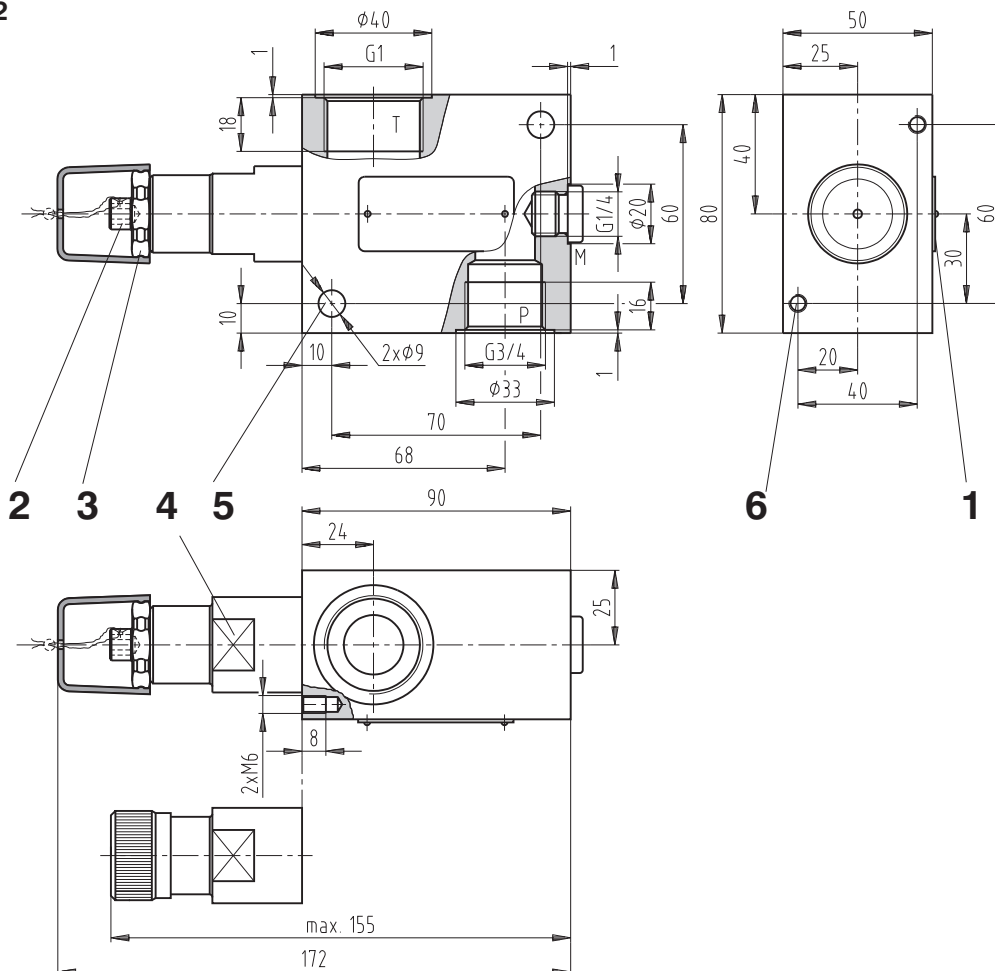

Valve Dimensions

Dimensions in millimetres

Model RC2, RC3

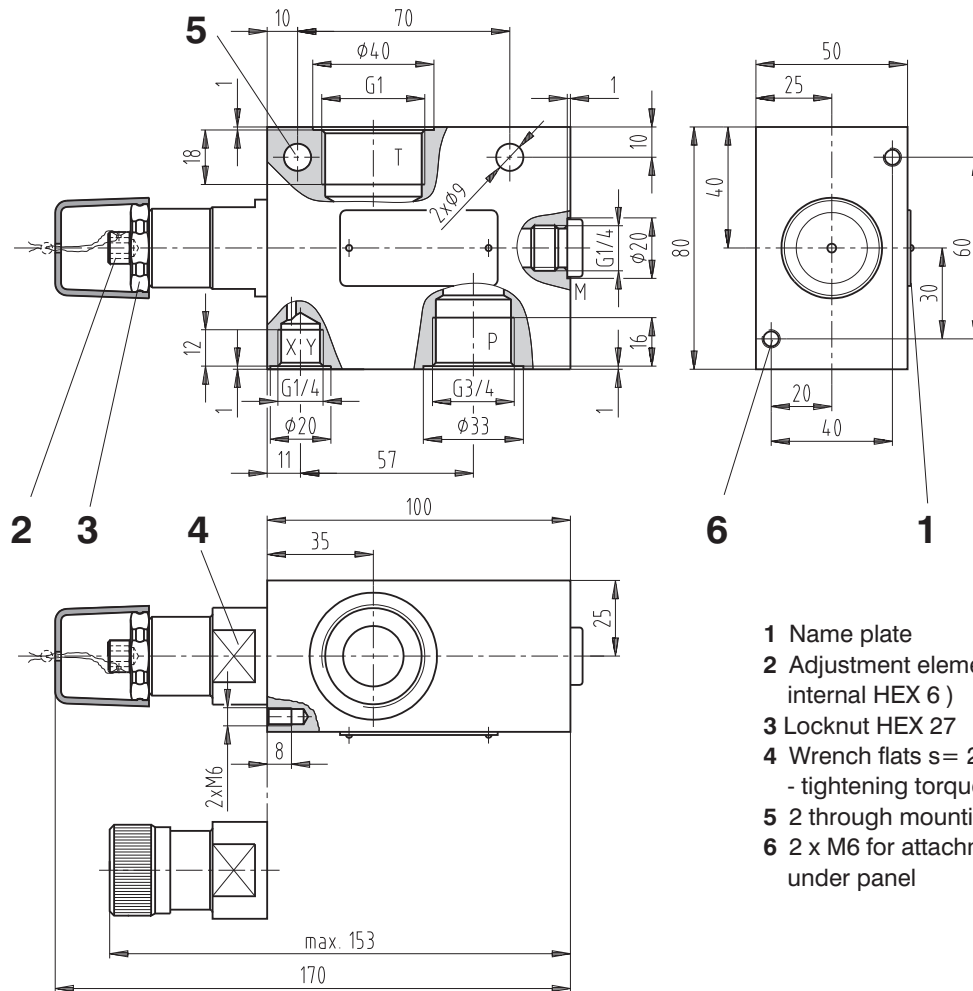

- 1 Name plate
- 2 Adjustment element (screw with internal HEX 6)
- 3 Locknut HEX 27
- 4 Wrench flats $s = 27$
- tightening torque 60Nm
- 5 2 through mounting holes
- 6 2 x M6 for attachment under panel

Spare Parts

Model	Dimensions, number	Ordering number
Modular valve - NBR	Square ring 12.42 x 1.68 NBR 70 (5 pcs.)	15991600
Modular valve - Viton	O-ring 12.42 x 1.78 (5 pcs.)	22943800
Model	Typ, number	Ordering number
In-line valve RA2 - NBR	VSTI R1/4-ED (1 pc.) VSTI R3/4-ED (1 pc.)	22972200
In-line valve RB2, RC2, RC3 - NBR	VSTI R1/4-ED (1 pc.)	22972400
In-line valve RA2 - Viton	VSTI R1/4-ED - Viton (1 pc.) VSTI R3/4-ED - Viton (1 pc.)	22972300
In-line valve RB2, RC2, RC3 - Viton	VSTI R1/4-ED - Viton (1 pc.)	22972500

Caution!

- The packing foil is recyclable.
- The protecting plate can be returned to the manufacturer.
- The technical information regarding the product presented in this catalogue is for descriptive purposes only. It should not be construed in any case as a guaranteed representation of the product properties in the sense of the law.

ARGO-HYTOS s.r.o. CZ - 543 15 Vrchlaví
Tel.: +420-499-403111, Fax: +420-499-403421
E-mail: sales.cz@argo-hytos.com
www.argo-hytos.com

- Screw-in cartridge design
- 3 pressure ranges
- Pressure setting by hexagon socket

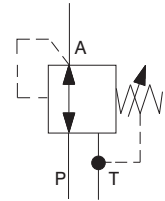

Functional Description

This 3 way direct operated pressure reducing valve is designed to reduce the system pressure. Due to its 3 way design the valve is capable to relief as well the secondary pressure. The pressure can be set by an adjustment screw (6).

In its initial position the valve allows free flow from port P to A. The pressure in port A acts on the front face of the control spool (2) against the spring (5). When the pressure in port A reaches the pressure set at the spring the control spool moves into the regulating position and closes the flow from port P to A until the pressure falls

back to the set pressure. This will maintain a constant pressure in line A. A further pressure increase in port A caused by a potential external force on the actuator will cause the spool to shift against the spring until the spool opens port T and allows the oil flow pass to tank.

The valve bush (1) is fixed to the cartridge (4) by a wire ring (3). Decoupling the bush from the cartridge makes a transmission of tensions caused by high tightening torques impossible. In the basic version the valve corpus and the adjustment screw are zinc plated

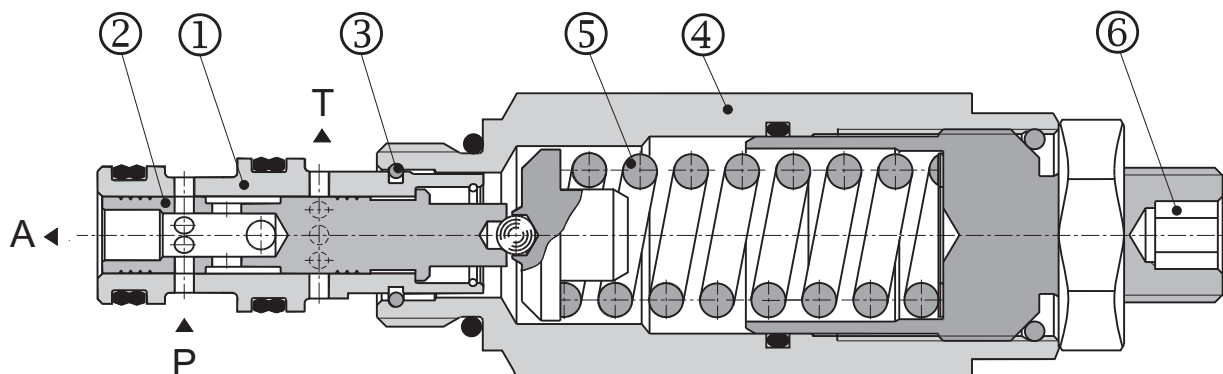

Ordering Code

SP2A-A3 /

**Directly Operated Pressure Reducing Valve
3/4-16 UNF**

without designation
V

Sealing
NBR
FPM (Viton)

Standard

S

06
16
21

Pressure range
up to 63 bar (914 PSI)
up to 160 bar (2321 PSI)
up to 210 bar (3046 PSI)

Technical Data

Valve size	A3		
Cartridge cavity	3/4-16 UNF-2A		
Max. flow rate	L/min (GPM)	20 (5,28)	
Max. input pressure (port P)	bar (PSI)	150 (2176) (pressure range 06)	250 (3626) (pressure range 16) 350 (5076) (pressure range 21)
Regulated pressure	bar (PSI)	63 (914)	50-160 (725-2321) 100-210 (1450-3046)
Working pressure related to flow	bar (PSI)	see p-Q characteristics	
Hydraulic fluid	Hydraulic oils of power classes (HL, HLP) to DIN 51524		
Fluid temperature range for standard sealing (NBR)	°C (°F)	-30 ... +100 (-22 ... 212)	
Fluid temperature range for Viton sealing (FPM)	°C (°F)	-20 ... +120 (-4 ... 248)	
Viscosity range	mm ² /s (SUS)	10 ... 500 (49 ... 2450)	
Max. degree of fluid contamination	Class 21/18/15 according to ISO 4406		
Weight	kg (lbs)	0,13 (0,286)	
Maximum valve tightening torque	Nm (lbf.ft)	30+2 (22.13+1.48 lbf.ft)	
Mounting position	unrestricted		
Valve body (data sheet HA 0018)	SB-A3		

p-Q Characteristics

Measured at $v = 32 \text{ mm}^2/\text{s}$ (156,8 SUS)

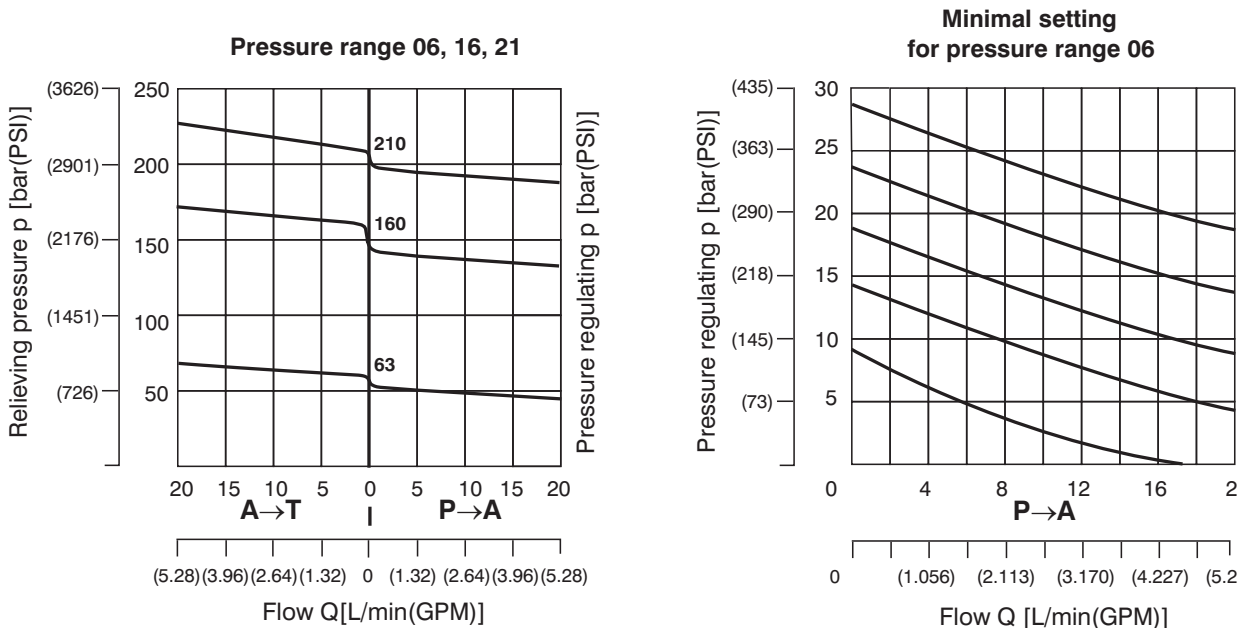

Δp-Q Characteristic

Measured at $v = 32 \text{ mm}^2/\text{s}$ (156,8 SUS)

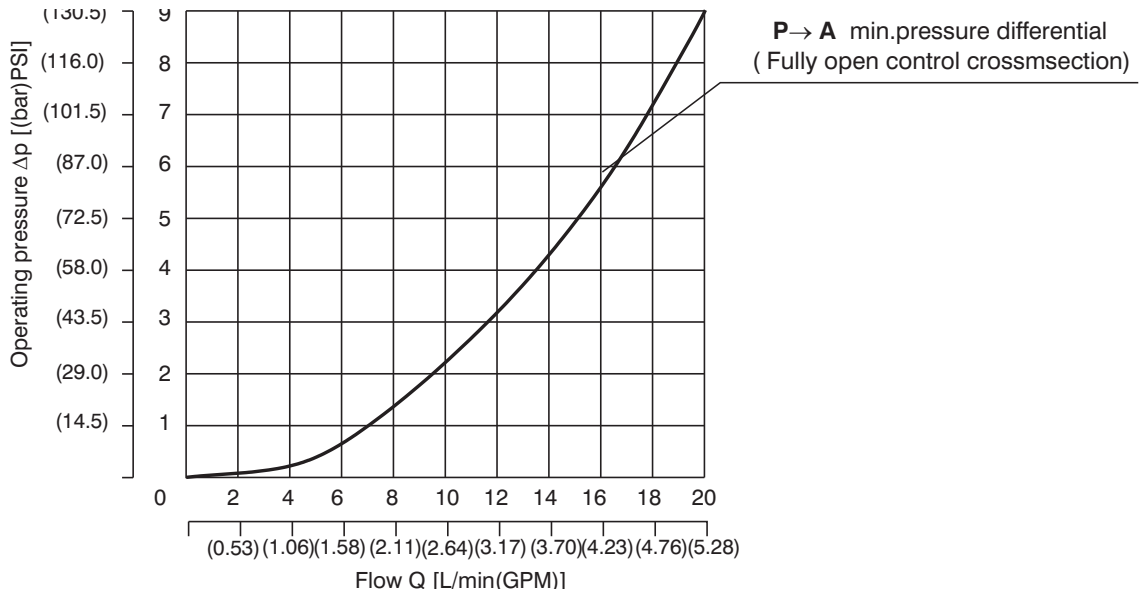

3

Valve Dimensions

Dimensions in millimeters (inches)

- 1 Adjustment element (screw with internal HEX 6)
Clockwise rotation = pressure increase
Atniclockwise rotation = pressure decrease
- 2 Locknut HEX 21 - tightening torque 15 Nm
- 3 Wrench flats HEX 27- tightening torque 30 Nm
- 4 O-ring 17 x 1,8 (supplied with valve)
- 5 Combined sealing:
Dualeal DRYZ000004Z20 11,87 x 14,27 x 3,1
Dualeal DRYZ000002Z20 13,47 x 15,87 x 3,1(supplied with valve)

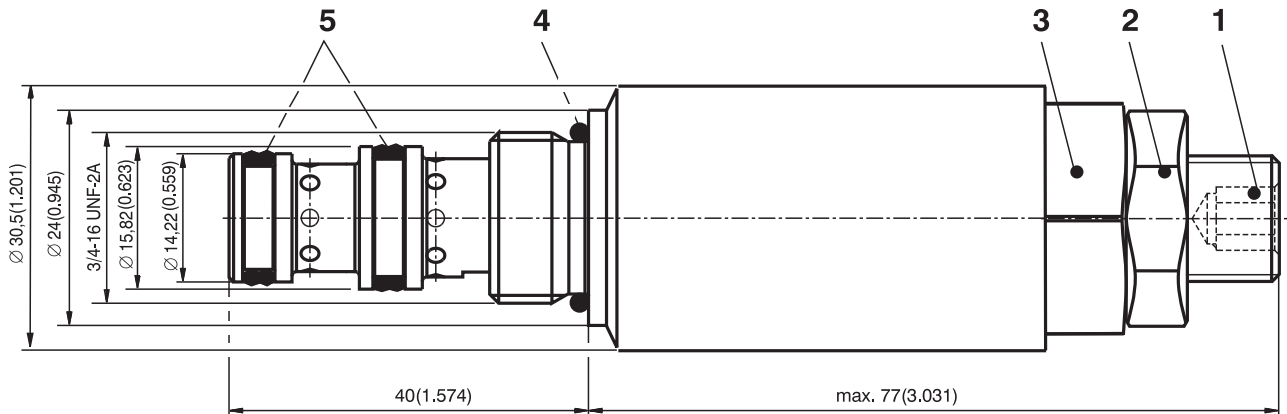

Cavity

Dimensions in millimeters (inches)

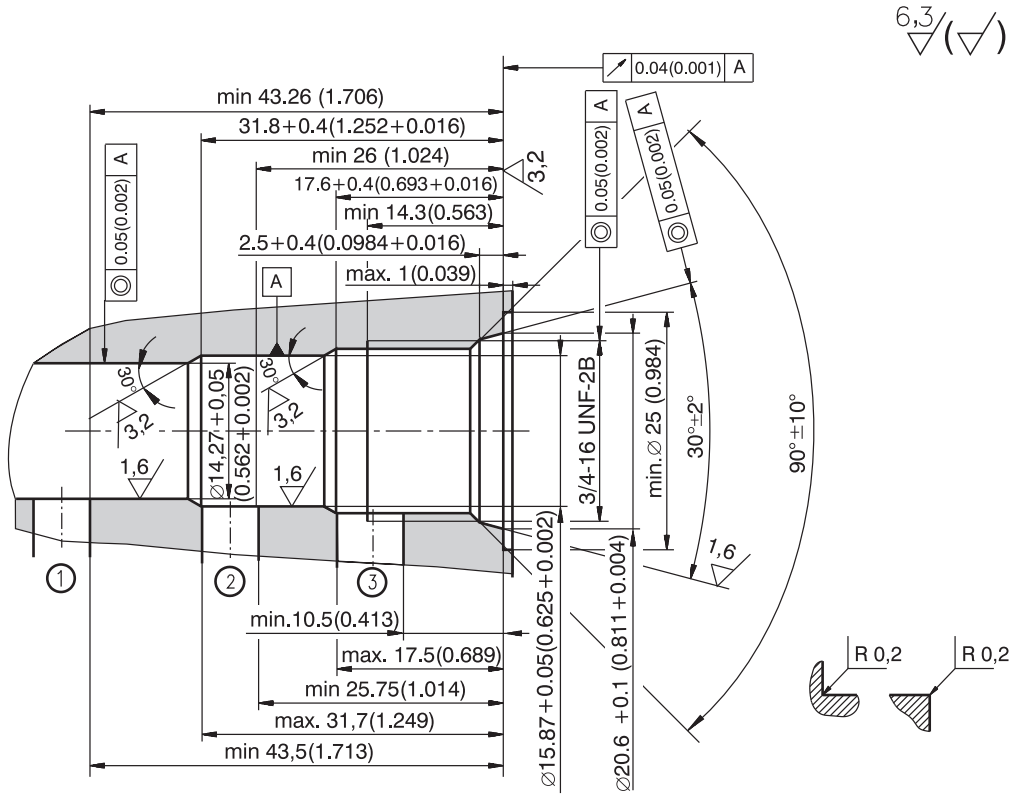

3

Spare Parts

Seal kit

Dualseal - PU	O-ring - NBR	O-ring - Viton	Order number
11,87 x 14,27 x 3,1 (1 pcs.)	17 x 1,8 (1 pcs.)	-	22565200
13,47 x 15,87 x 3,1 (1 pcs.)	20,35 x 1,78 (1 pcs.)	-	
11,87 x 14,27 x 3,1 (1 pcs.)	-	17 x 1,8 (1 pcs.)	22565100
13,47 x 15,87 x 3,1 (1 pcs.)	-	20,35 x 1,78 (1 pcs.)	

Caution!

- The packing foil is recyclable.
- The technical information regarding the product presented in this catalogue is for descriptive purposes only. It should not be construed in any case as a guaranteed representation of the product properties in the sense of the law.

ARGO-HYTOS s.r.o. CZ - 543 15 Vrchlábí
 Tel.: +420-499-403 111
 E-mail: info.cz@argo-hytos.com
 www.argo-hytos.com

- High pressure valve up to 420 bar
- Hardened and precision working parts
- Four Optional spring ranges
- Stable pressure characteristic in complete pressure range
- Quiet performance over complete power range

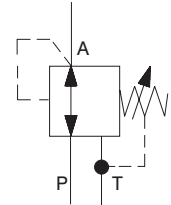

3

Functional Description

This 3 way direct operated pressure reducing valve is designed to reduce the system pressure. Due to its 3 way design the valve is also capable of relieving the secondary pressure. The pressure can be set by an adjustment screw (5).

This will maintain a constant pressure in line A. A further pressure increase in port A caused by a potential external force on the actuator will cause the spool to shift against the spring until the spool opens port T and allows the oil flow pass to tank.

In its initial position the valve allows free flow from port P to A. The pressure in port A acts on the front face of the control spool (2) against the spring (4). When the pressure in port A reaches the pressure set at the spring the control spool moves into the regulating position and closes the flow from port P to A until the pressure falls back to the set pressure.

The valve bush (1) is fixed to the cartridge (3). Uncoupling the bush from the cartridge makes a transference of tensions caused by high tightening torques impossible. In the basic version the valve corpus and the adjustment screw are zinc plated.

Model S

Model R

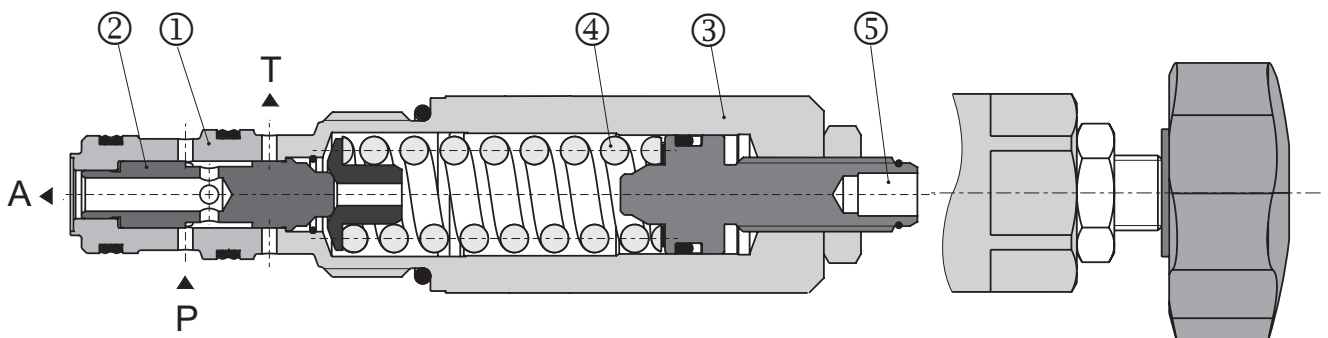

Ordering Code

Directly Operated Pressure Reducing Valve
7/8-14UNF

SP2A-B3/

no designation
V

Seals
NBR
FPM (Viton)

S
R

Adjustment option
Inside hexagon 5 mm
Adjustable handknob

High performance

H

3
8
11
15

Pressure range
Up to 30 bar (435 PSI)
Up to 80 bar (1160 PSI)
Up to 110 bar (1595 PSI)
Up to 150 bar (2176 PSI)

Technical Data

Valve size	B3			
Cartridge cavity	7/8-14 UNF-2A			
Flow range	L/min (GPM)	0 ÷ 60 (0 ÷ 15.85)		
Max. inlet pressure (port P)	bar (PSI)	420 (6092)		
Max. output pressure (port T)	bar (PSI)	200 (3626)		
Regulated pressure	bar (PSI)	30 (435)	80 (1160)	110 (1595) 150 (2176)
Working pressure related to flow	bar (PSI)	see p-Q characteristics		
Hydraulic fluid	Hydraulic oils of power classes (HL, HLP) to DIN 51524			
Fluid temperature range (NBR)	°C (°F)	-30 ... 100 (-22 ... 212)		
Fluid temperature range (FPM)	°C (°F)	-20 ... 120 (-4 ... 248)		
Viscosity range	mm ² /s (SUS)	10 ... 500 (49 ... 2450)		
Maximum degree of fluid contamination	Class 21/18/15 according to ISO 4406			
Weight	kg (lb)	0,26 (0.573)		
Maximum valve tightening torque	Nm (lbf.ft)	55+3 (40.57+2.21)		
Mounting position	unrestricted			
Valve body (data shee HA 0018)	SB-B3			

p-Q Characteristics

Measured at $v = 32 \text{ mm}^2/\text{s}$ (156 SUS)

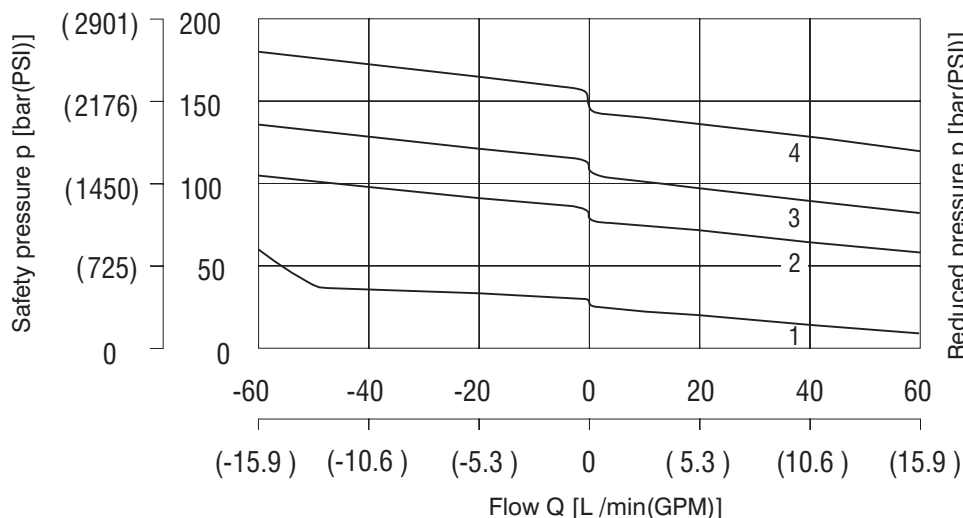

4	Pressure range 15
3	Pressure range 11
2	Pressure range 8
1	Pressure range 3

Δ p-Q Characteristics

Measured at $v = 32 \text{ mm}^2/\text{s}$ (156 SUS)

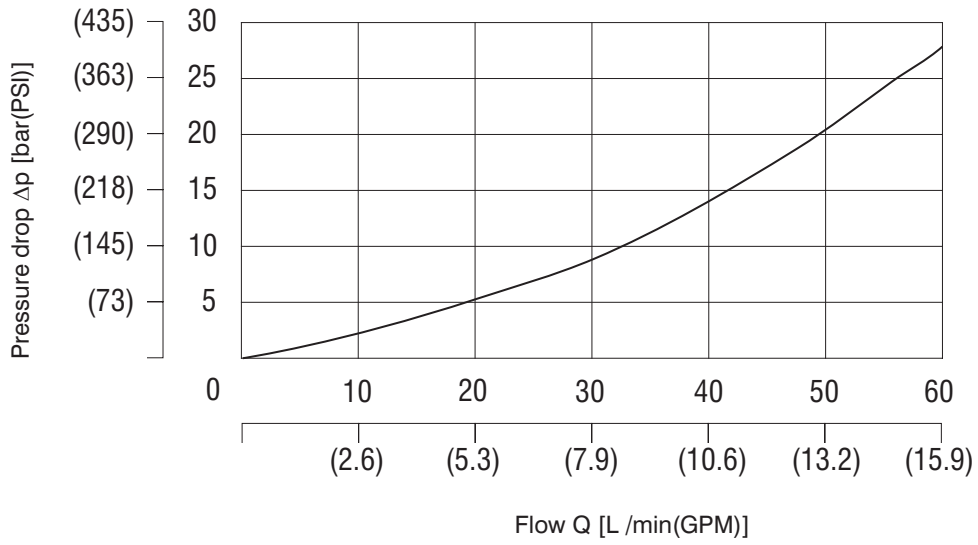

Valve Dimensions

Dimensions in millimeters (inches)

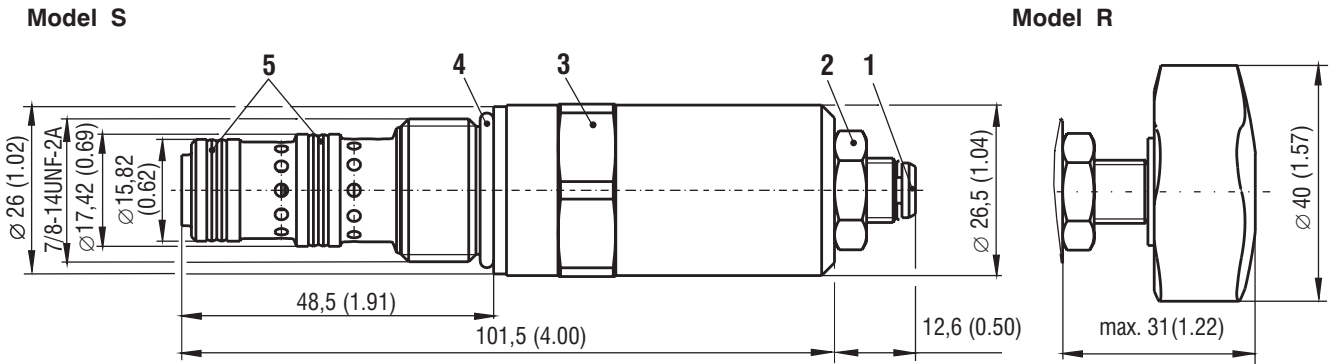

3

Cavity

Dimensions in millimeters (inches)

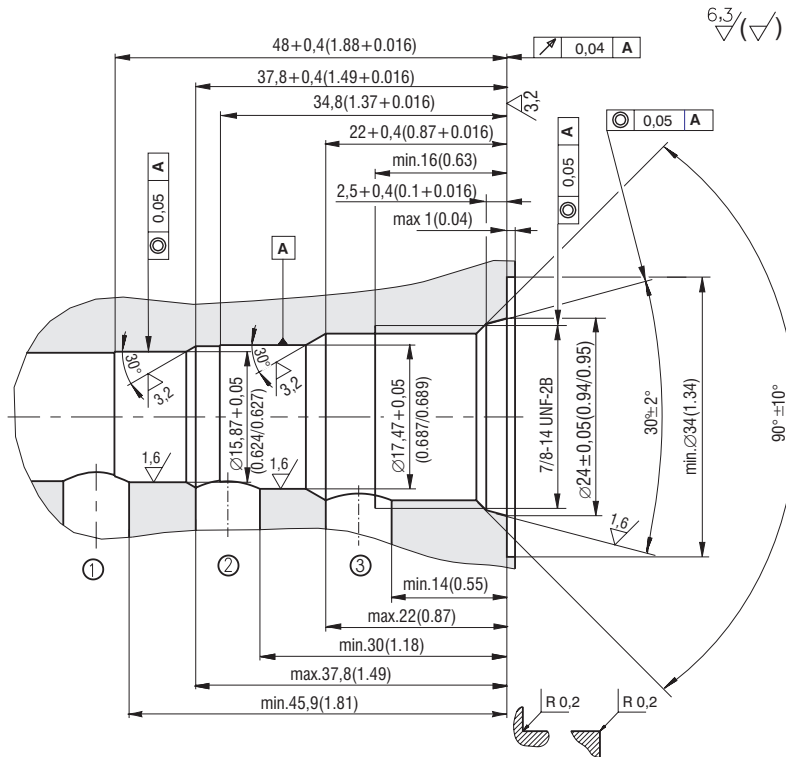

Spare Parts

Dimensions in millimeters

Type	Dimensions, quantity		Ordering number
NBR	O-ring	Dualseal - PU	
	19.4 x 2.1(1pc)	17.47 x 15.07 x 3.1(1pc)	20143900
		11.87 x 14.27 x 3.1(1pc)	24220800
FPM (Viton)	19.4 x 2.1(1pc)		20144100
		17.47 x 15.07 x 3.1(1pc)	24220800
		11.87 x 14.27 x 3.1(1pc)	20158500

Caution!

- The packing foil is recyclable.
- The technical information regarding the product presented in this catalogue is for descriptive purposes only. It should not be construed in any case as a guaranteed representation of the product properties in the sense of the law.

ARGO-HYTOS s.r.o. CZ - 543 15 Vrchlábí
 tel.: +420-499-403 111
 e-mail: info.cz@argo-hytos.com
 www.argo-hytos.com

- For stacking assemblies
- 4 pressure ranges
- Pressure reduction in ports A or P
- Model "A" with check valve
- Installation dimensions to ISO 4401/CETOP-RP 121H

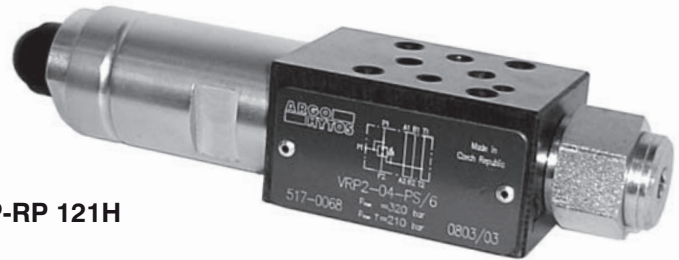
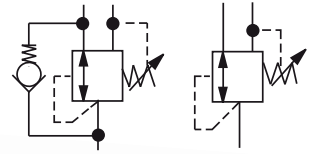

Functional Description

The pressure valves VRP2 are directly operated reducing valves for vertical stacking assemblies designed as 3 way valves, i.e. with pressure protection of the secondary circuit.

The valve consists of the valve body (1), control spool (2), spring (3), adjustment element (4) and the plug G 1/4 (5) for pressure measuring and, if necessary, of a check valve.

Model "A"

With this model, the fluid enters into the valve body from the primary circuit through port A1 and passes through the metering edge, where its pressure is reduced. The reduced pressure corresponds with the setting of the control spring. At the same time, this pressure affects also the surface area of the control spool opposed to the spring (the pressure can be measured at the port G 1/4 which is normally closed by plug 5). Thus the static balance of the spool is ensured. If the reduced pressure changes, a respective control action takes place and the reduced pressure returns to its preset value. The flow from the output port A2 passes then to the user. If pressure behind the valve increases due to the effect of the load acting on the user, the spool shifts further

against the spring until the second metering edge opens and the excessive flow drains through port T. The leakage from the spring room is also routed to port T. The reverse free-flow from port A2 to port A1 passes through a check valve which is connected parallel to the metering edge.

Model "B"

With model "B", the pressure reduction follows from port P2 to port P1, but it takes place only when the flow in port B passes in the direction to the user (not opposite). The protection of the secondary circuit is also ensured for one flow direction only.

Model "P"

With model "P", the pressure reduction follows from port P2 to port P1, but is effective in both flow directions through the directional valve (as well as the protection of the secondary circuit).

The valves are delivered with basic surface treatment. The valve body is phosphate coated, whereas the surfaces of the other parts are zinc coated.

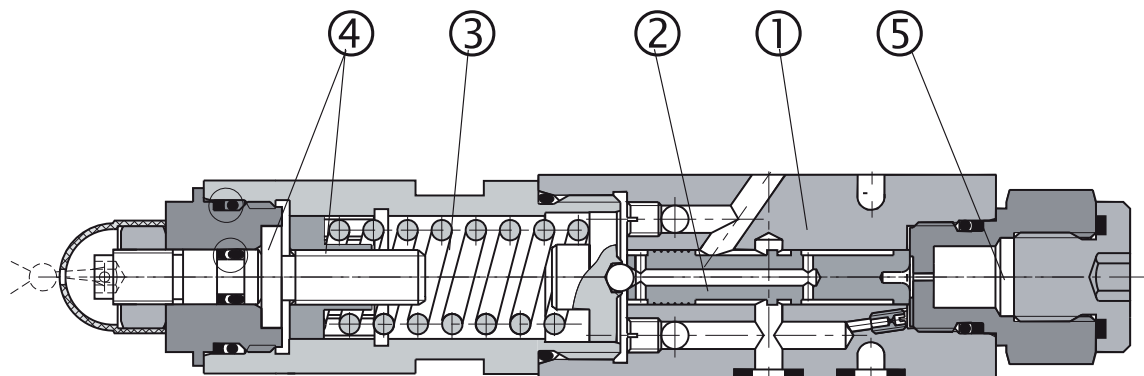

Ordering Code

VRP2-04- /

Reducing valve, directly operated

no designation

Seals
NBR

Nominal size **04 (D 02)**

Pressure range
2 Adjustable up to 25 bar(363 PSI)
6 Adjustable up to 63 bar (914 PSI)
16 Adjustable up to 160 bar(2321 PSI)
21 Adjustable up to 210 bar (3046 PSI)

Pressure reduction	Pressure control	
In port A2	from port A2	A
In port P1	from port B1	B
In port P1	from port P1	P

S **Adjustment element**
Screw with outside HEX 4

3

Functional Symbols

VRP 2-04-A . / . .

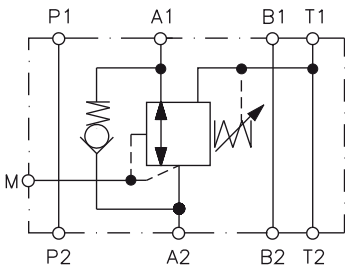

VRP 2-04-B . / . .

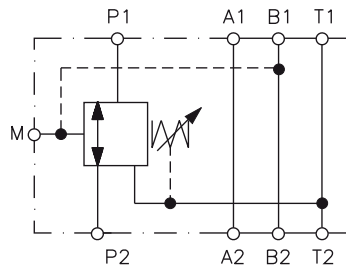

VRP 2-04-P . / . .

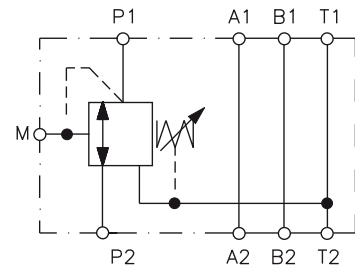

Technical Data

Nominal size	mm	04 (D02)
Maximal flow	L/min (GPM)	20 (5.3)
Max. service pressure ports (P, T, A, B)	bar (PSI)	320 (4600)
Working pressure related to flow	bar (PSI)	see p-Q characteristics
Hydraulic fluid		Hydraulic oils of power classes (HL, HLP) to DIN 51524
Fluid temperature range	°C (°F)	-30 ... +100 (-22 ... +212)
Viscosity range	mm ² /s (SUS)	20 .. 400 (98 ... 1840)
Maximum degree of fluid contamination		Class 21/18/15 to ISO 4406
Weight - model "A"	kg (lb)	0.82 (1.81)
model "B", "P"		0.60 (1.32)
Mounting position		unrestricted

Caution!

- The packing foil is recyclable. The protecting plate can be returned to the manufacturer.
- If the valve is used separately without a directional valve, a cover plate DK1-04/32-3 with the same installation dimensions can be ordered. This plate connect port A1 with port P1 - see catalogue Adapter and Blanking Plates HA 0003.
- Mounting bolts M5x50 or studs must be ordered separately. Tightening torque of the screws is 5 Nm (3.7 ft-lbs).
- For applications outside these parameters, please consult the manufacturer.
- The technical information regarding the product presented in this catalogue is for descriptive purposes only. It should not be construed in any case as a guaranteed representation of the product properties in the sense of the law.

p-Q Characteristics

Measured at $v = 32 \text{ mm}^2/\text{s}$ (156 SUS)

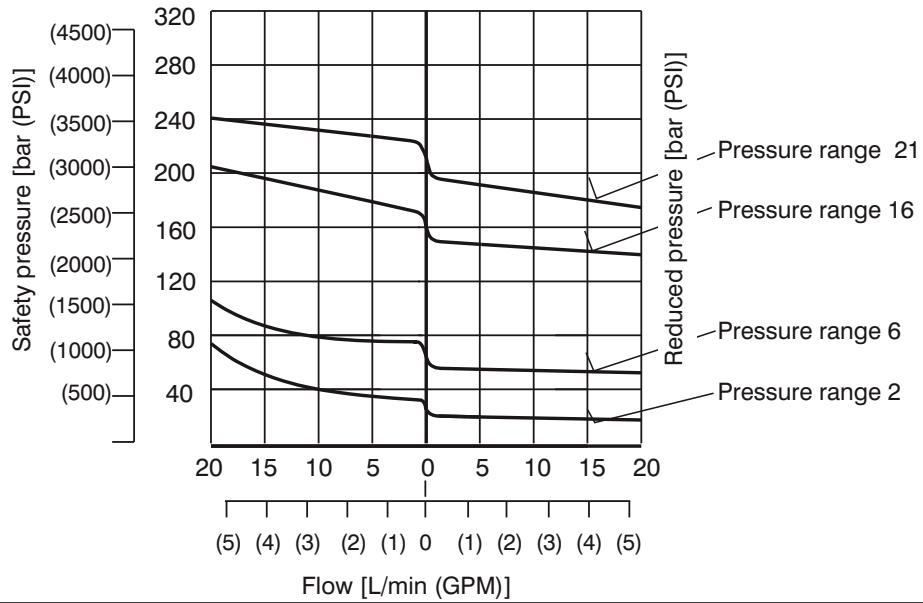

Δp -Q Characteristics

Measured at $v = 32 \text{ mm}^2/\text{s}$ (156 SUS)

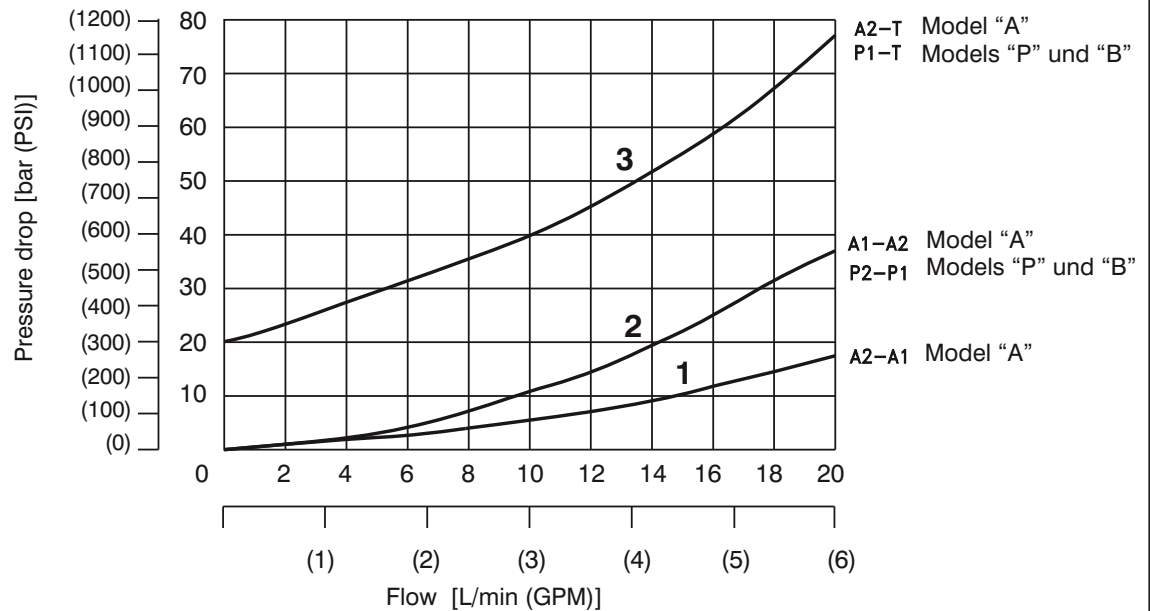

- 1 - Pressure drop of check valve
- 2 - Pressure drop of reducing valve = Min. adjustable pressure range
- 3 - Pressure drop of relief valve = Min. adjustable safety pressure

Spare Parts

Type	Dimensions, quantity	Ordering number
Standard NBR	O-ring 5 x 1,8 NBR 80 (1pcs)	15915600
	O-ring 12,42 x 1,78 NBR 70 (1pcs)	
	O-ring 18 x 2,65 NBR 70 (1pcs)	
	O-ring 6 x 1,5 OR1500600-N7003 (1pcs)	
	O-ring 20,35 x 1,78 ORAR00019-N9002 (1pcs)	
	DKAR 00009-N7028 5,28 x 1,68 NBR 70 (1pcs)	
	DKAR 00011-N7028 7,65x1,68 (4pcs)	
	Back-up ring BBP80B014-N9 13,16 x 15,86 x 1,14 (1pcs)	
Back-up ring BBP80B115-N962N 17,83 x 22,19 x 1,14 (1pcs)		

Valve Dimensions

Dimensions in millimeters (inches)

Model „A“

Type VRP2-04-AS/ ..

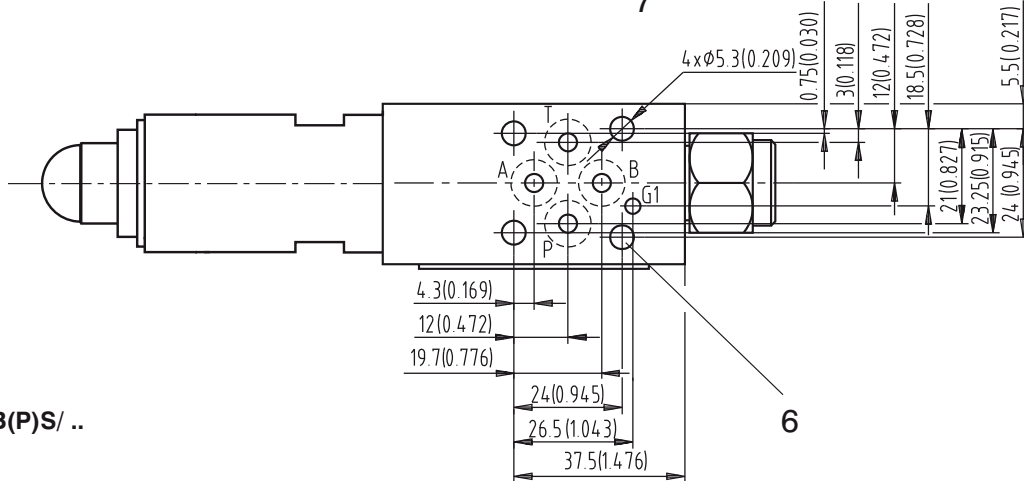
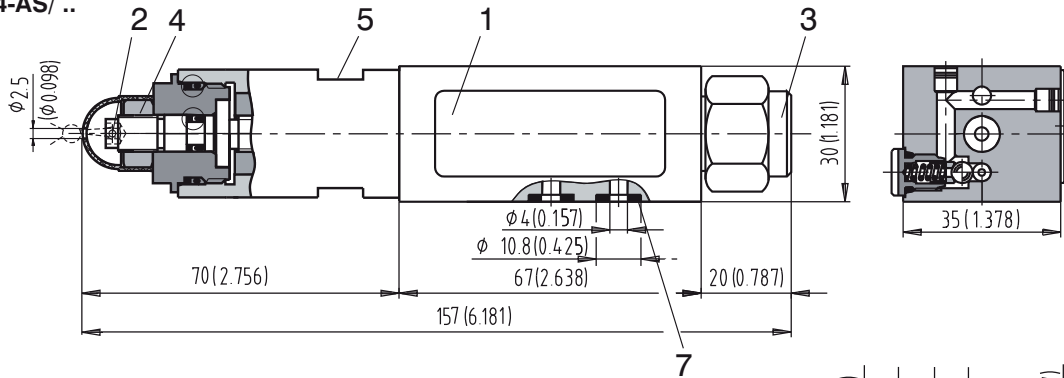

Model „B“ an

Type VRP2-04-B(P)/ ..

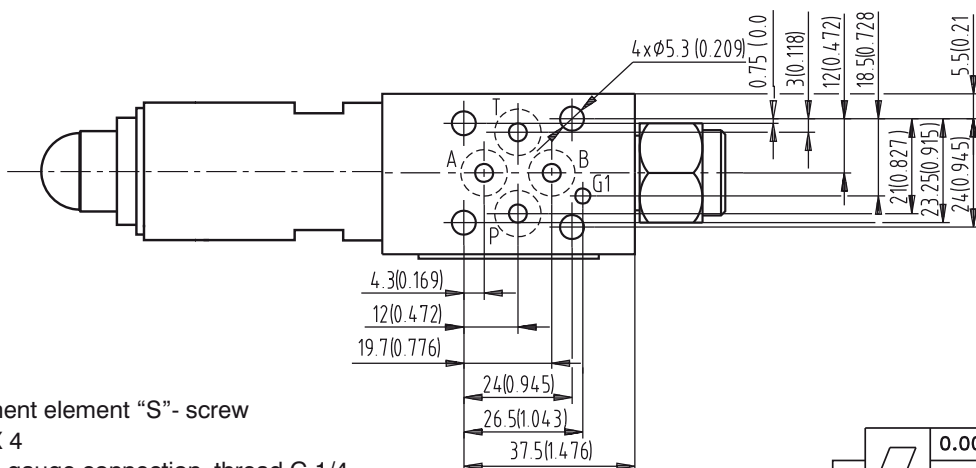
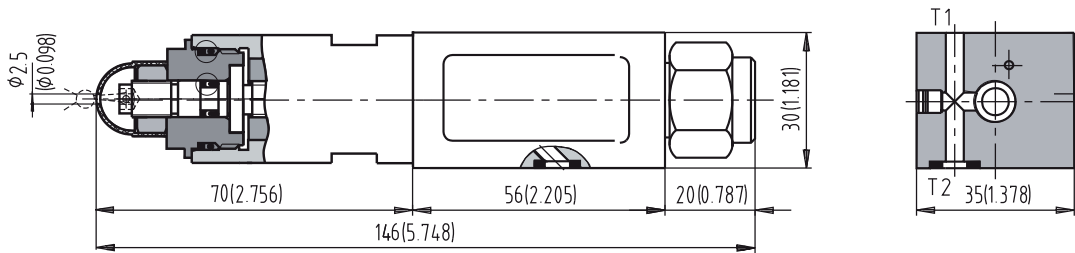

- 1 Name plate
- 2 Pressure adjustment element "S"- screw with outside HEX 4
- 3 Plug for pressure gauge connection, thread G 1/4
- 4 Locknut HEX 13
- 5 Wrench flats s=24mm
- 5 4 through mounting holes
- 6 Square ring 7.65x1.68 (4 pcs.), supplied with each valve

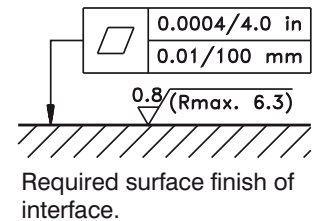

ARGO-HYTOS s.r.o. CZ - 543 15 Vrchlaví
 Tel.: +420-499-403111, Fax: +420-499-403421
 E-mail: sales.cz@argo-hytos.com
 www.argo-hytos.com

- ❑ For stacking assemblies
- ❑ 4 pressure ranges
- ❑ Pressure reduction in ports P
- ❑ Installation dimensions to ISO 4401/CETOP-RP 121H

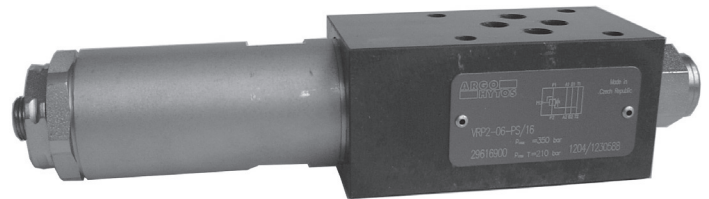
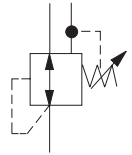

Functional Description

The pressure valves VRP2 are directly operated reducing valves for vertical stacking assemblies designed as 3 way valves, i.e. with pressure protection of the secondary circuit.

The valve consists of the valve body (1), control spool (2), spring (3), adjustment element (4) and the plug G1/4 (5) for pressure measuring

Model "B"

With model "B", the pressure reduction follows from port P2 to port P1, but it takes place only when the flow in port B passes in the direction to the user (not opposite). The protection of the secondary circuit is also ensured for one flow direction only.

Model "P"

With model "P", the pressure reduction follows from port P2 to port P1, but is effective in both flow directions through the directional valve (as well as the protection of the secondary circuit).

The valves are delivered with basic surface treatment. The valve body is phosphate coated, whereas the surfaces of the other parts are zinc coated.

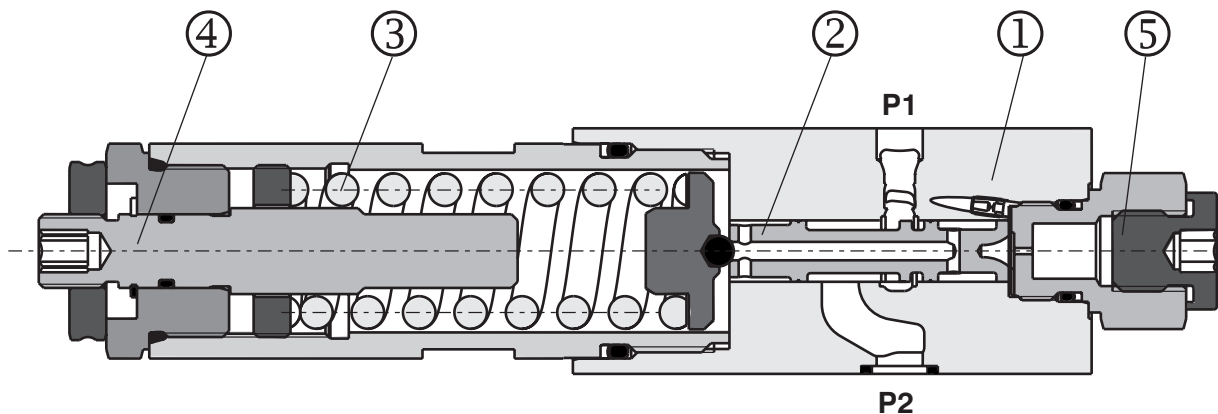

Ordering Code

VRP2 - 06 - /

Reducing valve, directly operated

Nominal size

no designation

Seals
Standard (NBR)

Pressure reduction Pressure control

in port P1 from port B1
in port P1 from port P1

B
P

Pressure range

2 Adjustable up to 25 bar (363 PSI)
6 Adjustable up to 63 bar (914 PSI)
16 Adjustable up to 165 bar (2321 PSI)
21 Adjustable up to 210 bar (3046 PSI)

Adjustment element

Screw with outside HEX 6

S

Functional Symbols

VRP 2-06-B . / . .

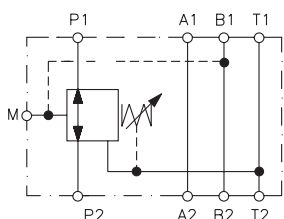

VRP 2-06-P . / . .

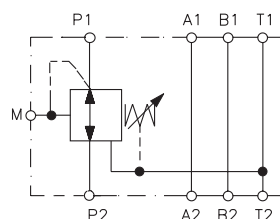

Technical Data

Nominal size		06 (D03)
Maximal flow	l/min (GPM)	50 (13.2)
Max. service pressure ports (P, T)	bar (PSI)	350 (5076)
Working pressure related to flow	bar (PSI)	see p-Q characteristics
Hydraulic fluid		Hydraulic oils of power classes (HL, HLP) to DIN 51524
Fluid temperature range	°C (°F)	-30 ... +100 (-22 ... +212)
Viscosity range	mm ² /s (SUS)	20 .. 400 (98 ... 1840)
Maximum degree of fluid contamination		Class 21/18/15 to ISO 4406
Weight	kg (lb)	1,50 (3.31)
Mounting position		unrestricted

p-Q Characteristics

Measured at $v = 32 \text{ mm}^2/\text{s}$ (156 SUS)

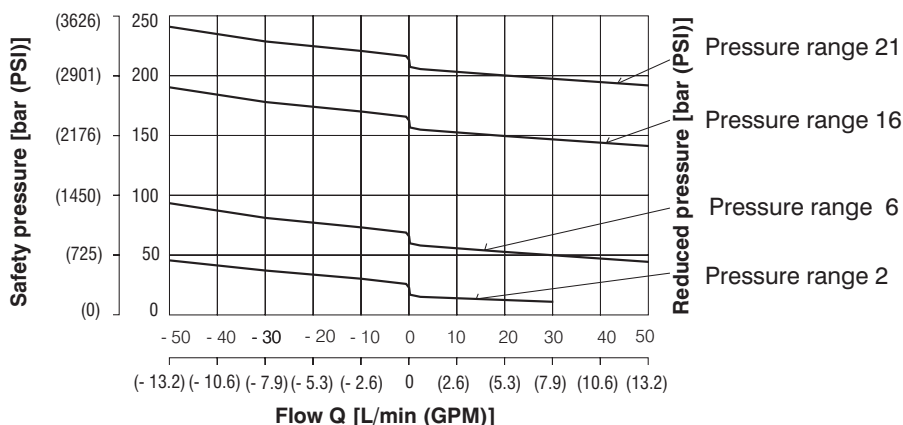

Δp-Q Characteristics

Measured at $v = 32 \text{ mm}^2/\text{s}$ (156 SUS)

Pressure drop of reducing valve

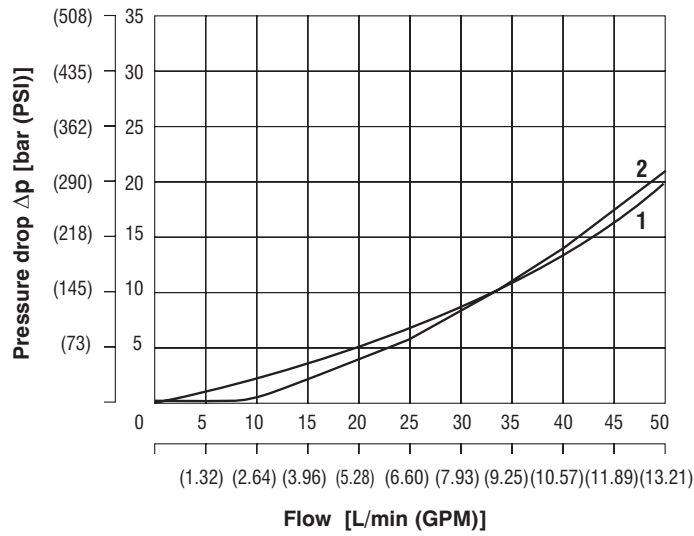

Model „B“ and „P“

Flow in direction	
1	P2 → P1
2	P1 → T

Valve Dimensions

Dimensions in millimeters (inches)

Model „B“ and „P“

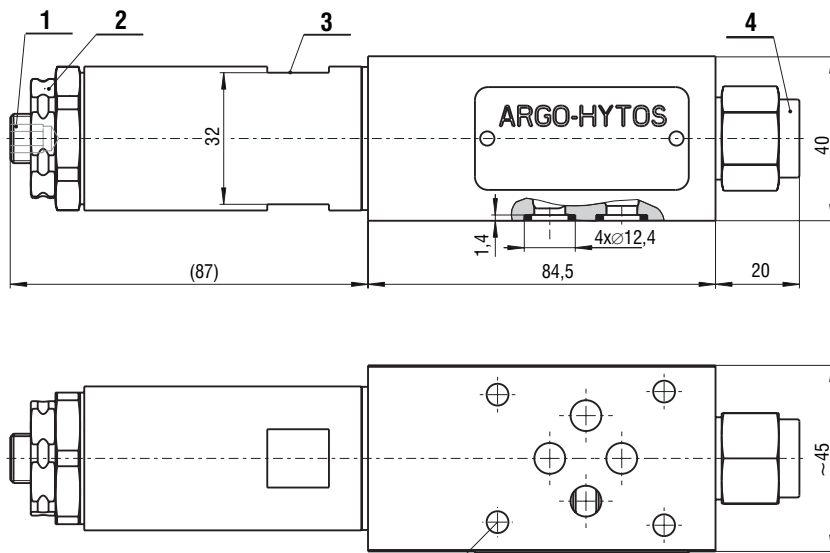
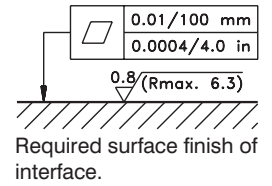

Dimensions to ISO 4401

- 1 Pressure adjustment element “S”- screw with outside HEX 6
- 2 Locknut HEX 27
- 3 Wrench flats $s = 32 \text{ mm}$ (1.26 inch)
- 4 Plug for pressure gauge connection, thread G 1/4

Spare Parts

Seal kit

Type	Dimension, quantity	Ordering number
	Square ring	
Standard - NBR	9,25x1,6 DKAR00012BN7033 (4 pc.)	15608800

3

Caution!

- The plastic packing foil is recyclable.
- The transport plate can be returned to the manufacturer.
- If the valve is used separately without a directional valve, a cover plate DK1-06/32-3 with the same installation dimensions can be ordered. This plate connect port A1 with port P1 - see catalogue Adapter and Blanking Plates HA 0003.
- Mounting bolts M5x55 or studs must be ordered separately. Tightening torque of the screws is 8,9 Nm (6.56 lbf-ft).
- For applications outside these parameters, please consult the manufacturer.
- The technical information regarding the product presented in this catalogue is for descriptive purposes only. It should not be construed in any case as a guaranteed representation of the product properties in the sense of the law.

ARGO-HYTOS s.r.o. CZ - 543 15 Vrchlabí
 tel.: +420-499-403 111
 e-mail: info.cz@argo-hytos.com
 www.argo-hytos.com

- Screw-in cartridge valve for manifold mounting and stacking assemblies
- 4 pressure ranges
- Two pressure adjustment options
- Pressure reduction in ports A or P
- Model MA with check valve
- Installation dimensions to ISO 4401-AB-03-4-A and DIN 24 340-A6

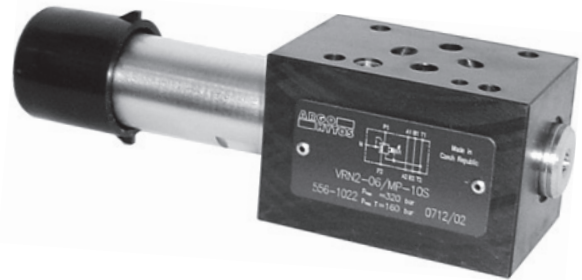
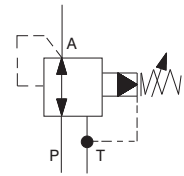

3

Functional Description

The pressure valves VRN2 are pilot operated screw-in cartridge pressure reducing valves designed as 3 way valves, i.e. with pressure protection of the secondary circuit. For the use in vertical stacking assemblies, two models of valve bodies are available, with pressure reduction in ports A and P. Incorporated into the valve bodies MA are the check valves which enable the reverse flow to pass through the valve.

The reducing valve consists of a cartridge (1) with thread M22x1.5, control spool (2) and the adjustment element (4). With the models for stacking assemblies also the respective valve body (5) and alternatively a check valve (6) complete the valve.

Screw-in cartridge valve

The flow from the primary circuit flows to the first metering edge, where its pressure is reduced. The reduced pressure corresponds with the adjustment of the control spring of the ball pilot valve. The reduced pressure is continuously controlled and compared with the pressure preset. If any control error appears, the respective control action takes place and the reduced pressure returns to its preset value. After the pressure reduction, the fluid flows through the spool bore and is

then routed to the output port of the module valve body. If pressure behind the valve increases due to the effect of external load acting on the user, the control spool shifts further against the spring, the reducing metering edge closes and the second metering edge opens. The fluid passes through the „third way“ to port T. The control flow of the pilot valve (from the spring room) is also routed to port T.

Model MA

With this model, the flow enter into the valve body through port A1. The input pressure is reduced, routed to port A2 and further to the user. The reverse flow passes through a check valve which is connected parallel to the metering edge.

Model MP

With the model MP, the pressure is reduced from port P2 to port P1.

With all models, a control pressure gauge can be connected to port G 1/4 (7).

The valve body and the adjustment screw are zinc coated. With model M the valve bodies are phosphate coated.

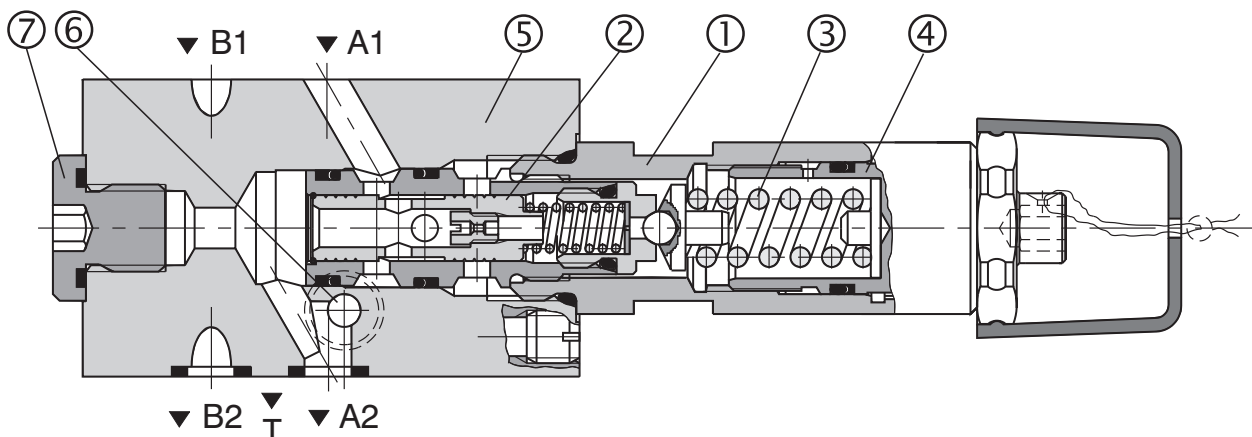

Ordering Code

VRN2-06/ -

Pilot Operated Pressure Reducing Valve

Sealing
without designation
V
NBR
Viton

Nominal size

Adjustment element
S
R
screw with internal hexagon 6 mm
hand knob

Model

screw in cartridge
modular valve, pressure reduction in port A
modular valve, pressure reduction in port P

S
MA
MP

6
10
16
21

Pressure range
up to 63 bar
up to 100 bar
up to 160 bar
up to 210 bar

FOR PREFERRED TYPES SEE BOLD TYPING IN ORDERING CODE AND TABLE OF PREFERRED TYPES ON PAGE 6

Functional Symbols

Model **MA**

Model **MP**

Valve side

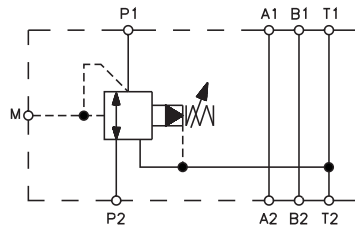
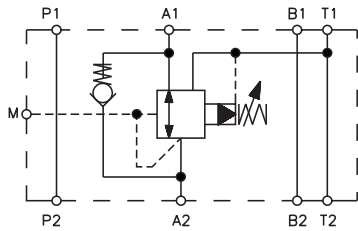

Subplate side

Ordering Numbers of Sandwich / Valve Bodies (without screw-in cartridge)

Valve body for modular valve - NBR	Ordering number	Valve body for modular valve - Viton	Ordering number
MA06-VRN2	16002400	MA06-VRN2/V	22995500
MP06-VRN2	16002200	MP06-VRN2/V	22995000

Technical Data

Nominal size	mm	06
Maximal flow rate	L/min	40
Maximum pilot flow	L/min	0.25
Max. input pressure (port P)	bar	320
Max. output pressure (port T)	bar	160
Working pressure related to flow	bar	see p-Q characteristics
Hydraulic fluid		Hydraulic oils of power classes (HL, HLP) to DIN 51524
Fluid temperature range (NBR / Viton)	°C	-30 ... +100 / -20 ... +120
Viscosity range	mm ² /s	20 ... 400
Maximum degree of fluid contamination		Class 21/18/15 according to ISO 4406
Weight: model S model MA model MP	kg	0,22 1,20 1,10
Mounting position		unrestricted

3

p-Q Characteristics

Measured at $v = 32 \text{ mm}^2/\text{s}$

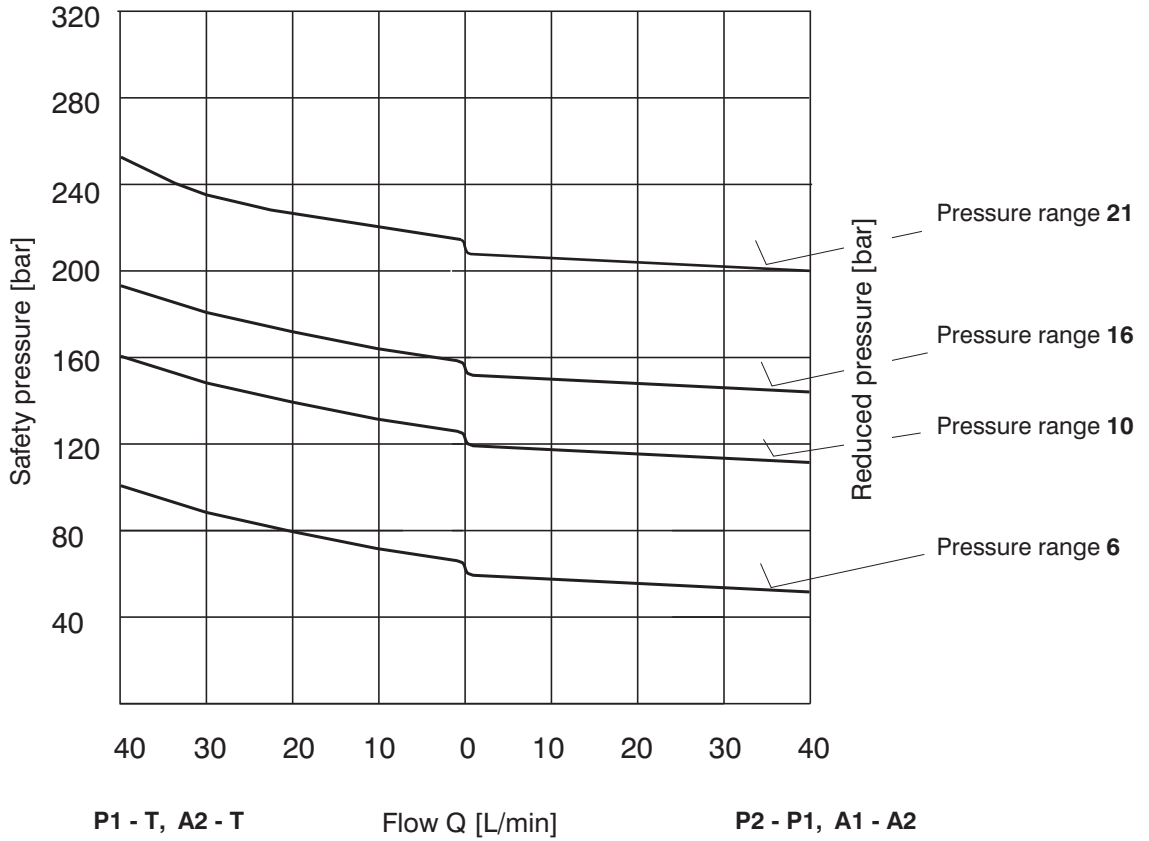

3

Δp -Q Characteristics

Measured at $v = 32 \text{ mm}^2/\text{s}$

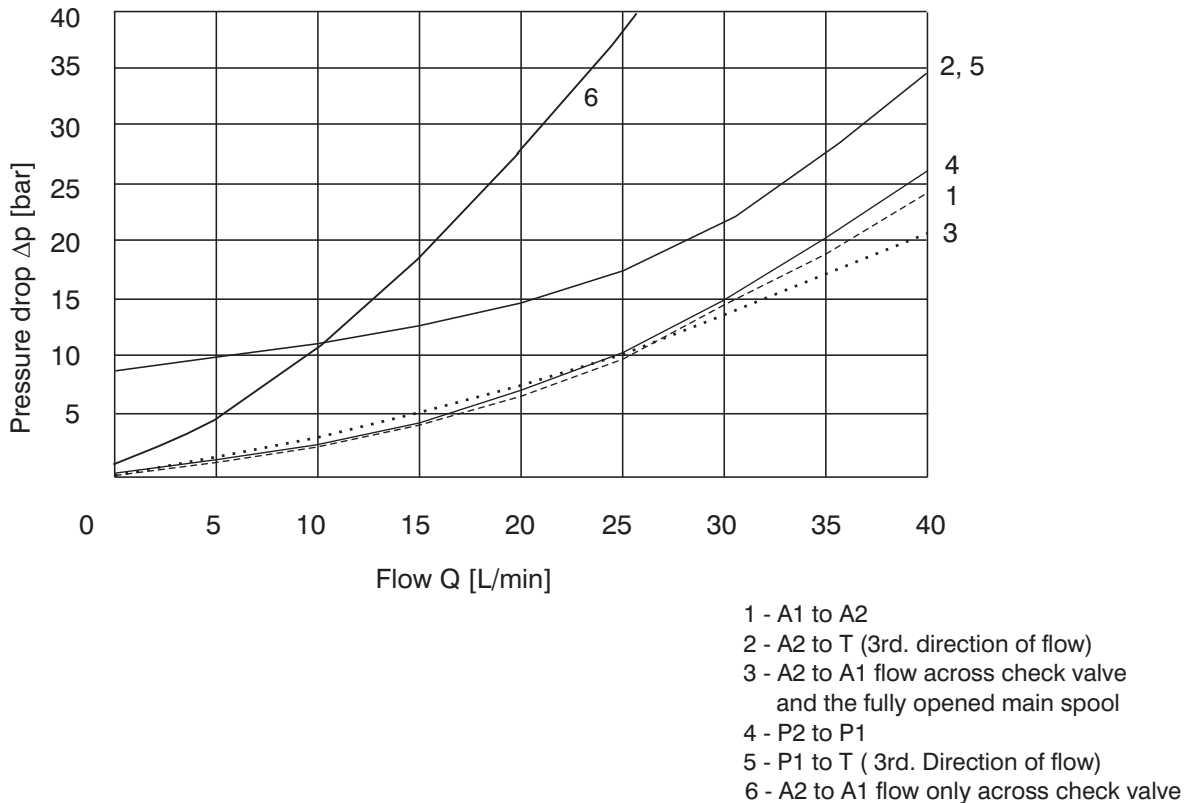

Valve Dimensions

Dimensions in millimeters

Model R

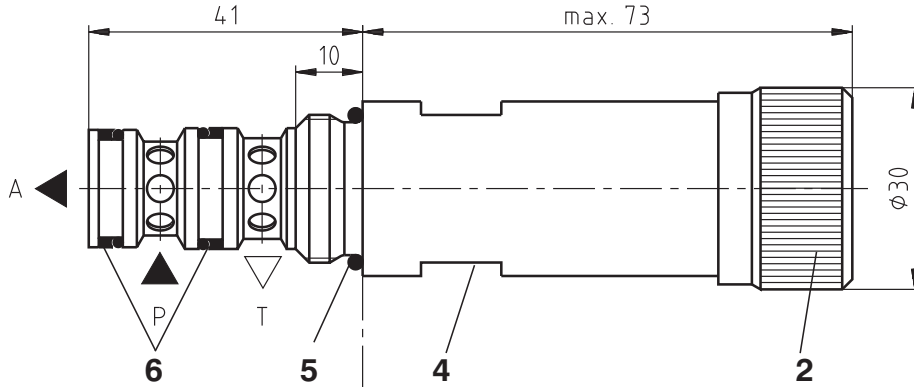

Model S

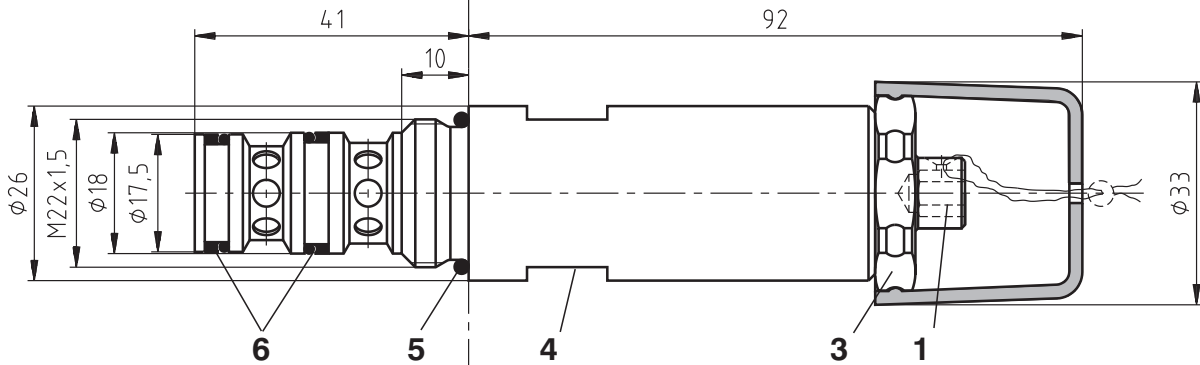

- 1 Adjustment element S [screw with internal HEX 6]
- 2 Adjustment element R (hand knob)
- 3 Locknut HEX 27
- 4 Wrench flats $s = 24$ mm - tightening torque 30 Nm
- 5 O-ring 19,4 x 2,1 NBR 80 (1 pc.), supplied with valve
- 6 Combined sealing: O-ring 14 x 1,78 NBR 90 (2 pcs.)
Back-up ring 14,73 x 17,43 x 1,14 (2 pcs.)
(supplied with valve)

Cavity

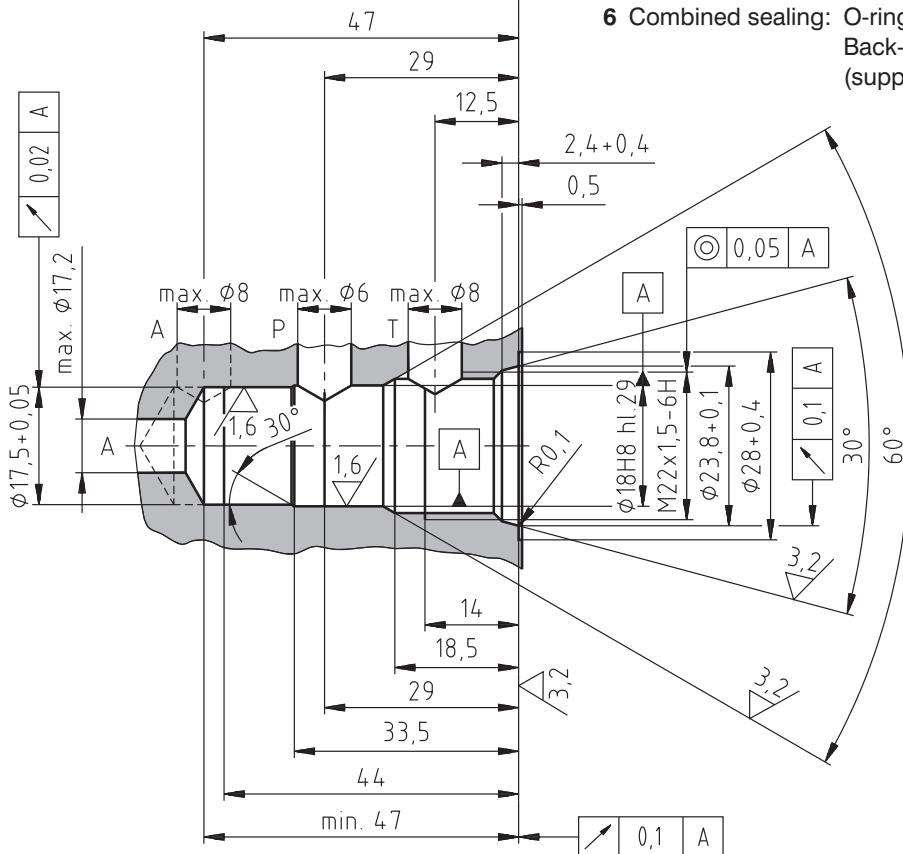

Valve Dimensions

Dimensions in millimeters

Model MA

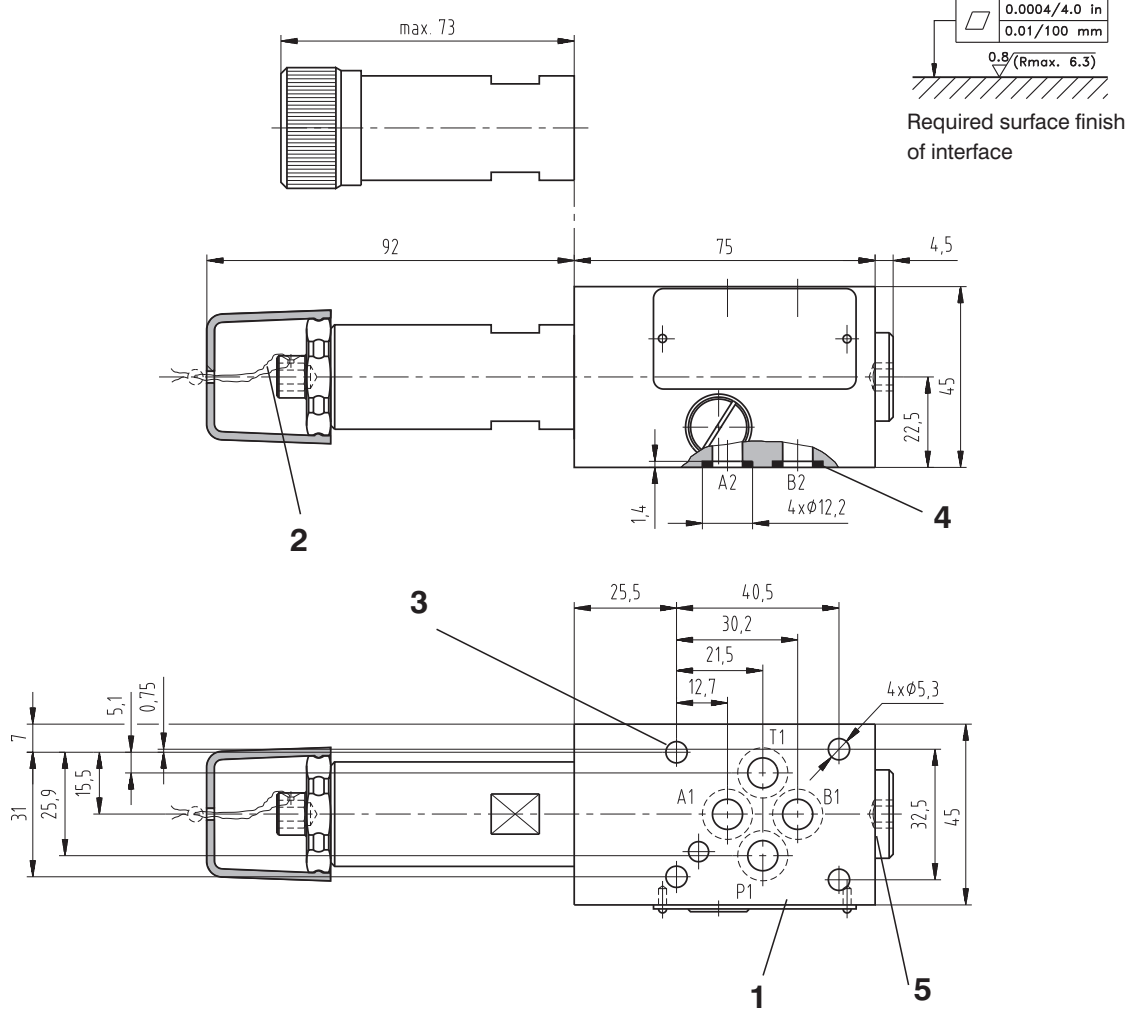

Model MP

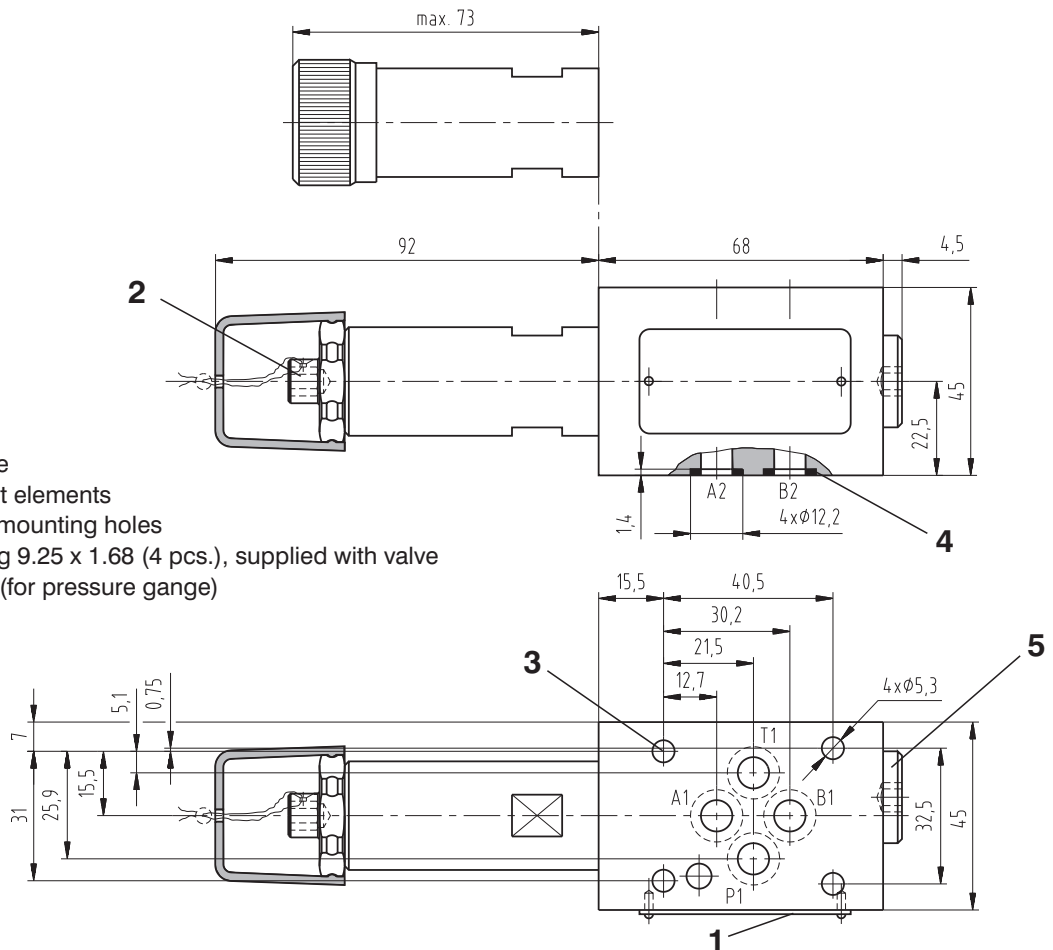

- 1 Name plate
- 2 Adjustment elements
- 3 4 through mounting holes
- 4 Square ring 9.25 x 1.68 (4 pcs.), supplied with valve
- 5 Plug G1/4 (for pressure gange)

3

Spare Parts

Model	Dimensions, quantity	Ordering number
Screw-in cartridge - NBR	O-ring 9 x 1,8 NBR 70 (1 pc.)	17363800
	O-ring 14 x 1,78 NBR 90 (2 pc.)	
	O-ring 17 x 1,8 NBR 70 (1 pc.)	
	O-ring 19,4 x 2,1 NBR 80 (1 pc.)	
	Back-up ring BBP80B015-N9 14,73 x 17,43 x 1,14 (2 pcs.)	
	Back-up ring BBP80-B-016-N9 16,33 x 19,03 x 1,14 (1 pc.)	
Screw-in cartridge - Viton	O-ring 9,25 x 1,78 (1 pc.)	22925500
	O-ring 14 x 1,78 (2 pcs.)	
	O-ring 17,17 x 1,78 (1 pc.)	
	O-ring 19,4 x 2,1 (1 pc.)	
	Back-up ring 14,73 x 17,43 x 1,14 (2 pcs.)	
Model	Dimensions, quantity	Ordering number
Modular valve - NBR	O-ring 9 x 1,8 (1 pc.)	15987200
	O-ring 14 x 1,78 (2 pcs.)	
	O-ring 17 x 1,8 (1 pc.)	
	O-ring 9,75 x 1,78 (1 pc.)	
	O-ring 19,4 x 2,1 (1 pc.)	
	Back-up ring 14,73 x 17,43 x 1,14 (2 pcs.)	
	Back-up ring 16,33 x 19,03 x 1,14 (1 pc.)	
	Square ring 9,25 x 1,68 (4 pcs.)	
Modular valve - Viton	O-ring 9,25 x 1,78 (5 pcs.)	22925600
	O-ring 14 x 1,78 (2 pcs.)	
	O-ring 17,17 x 1,78 1 pc.)	
	O-ring 19,4 x 2,1 (1 pc.)	
	Back-up ring 14,73 x 17,43 x 1,14 (2 pcs.)	
	Back-up ring 17,4 x 1,3 (1 pc.)	

Preferred Types of Valves

Type	Ordering Number
VRN2-06/S-10S	15997200
VRN2-06/S-21S	15997500
VRN2-06/MP-10S	15998400
VRN2-06/MP-21S	15999000

Caution!

- The packing foil is recyclable.
- The protecting plate can be returned to the manufacturer.
- Mounting studs must be ordered separately. Tightening torque is 8.9 Nm.
- The technical information regarding the product presented in this catalogue is for descriptive purposes only. It should not be construed in any case as a guaranteed representation of the product properties in the sense of the law.

ARGO-HYTOS s.r.o. CZ - 543 15 Vrchlaví
 Tel.: +420-499-403111, Fax: +420-499-403421
 E-mail: sales.cz@argo-hytos.com
 www.argo-hytos.com

- Screw-in cartridge valve for manifold mounting and stacking assemblies
- 4 pressure ranges
- Two pressure adjustment options
- Pressure reduction in ports A, B or P
- Model MA a MB with check valve
- Installation dimensions to ISO 4401 and DIN 24 340-A10

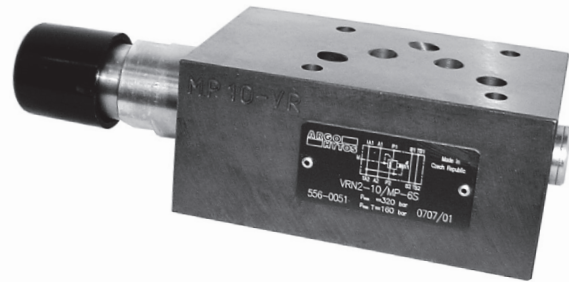
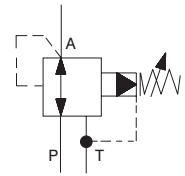

Functional Description

The pressure valves VRN2 are pilot operated screw-in cartridge pressure reducing valves designed as 3 way valves. For the use in vertical stacking assemblies, three models of valve bodies are available, with pressure reduction in ports A, B and P. Incorporated into the valve bodies MA, MB are the check valves which enable the reverse flow to pass through the valve.

The reducing valve consists of a cartridge (1) with thread M27x2, control spool (2), spring (3) and the adjustment element (4). With the models for stacking assemblies also the respective valve body (5) and alternatively a check valve (6) complete the valve.

Screw-in cartridge valve

At rest, the valves are open, i.e. oil can flow from input line via the main spool to output line. At the same time there is pressure from output line via the main spool with bore and jets and at the spring-loaded side of the main spool and at the side opposite the spring. If pressure in output line exceeds the value set at the spring the pilot poppet opens. Oil now flows from the spring loaded side of the main spool via the jet and pilot poppet into the chamber. The main spool moves into

control position and holds the value set at the spring in output line constant. If pressure behind the valve increases due to the effect of external load acting on the user, the control spool shifts further against the spring, the input line closes and the flow from output line to port T opens. The control flow of the pilot valve (from the spring room) is also routed to port T.

Model MA and MB

With these models, the flow enters into the valve body through port A1 (B1). The input pressure is reduced, routed to port A2 (B2) and further to the user. The reverse flow passes through a check valve which is connected parallel to the metering edge.

Model MP

With the model MP, the pressure is reduced from port P2 to port P1. With all models, a control pressure gauge can be connected to port G 1/4 (7).

The screw-in cartridge valve body and the adjustment screw are zinc coated. With models for stacking assemblies the valve bodies are phosphate coated.

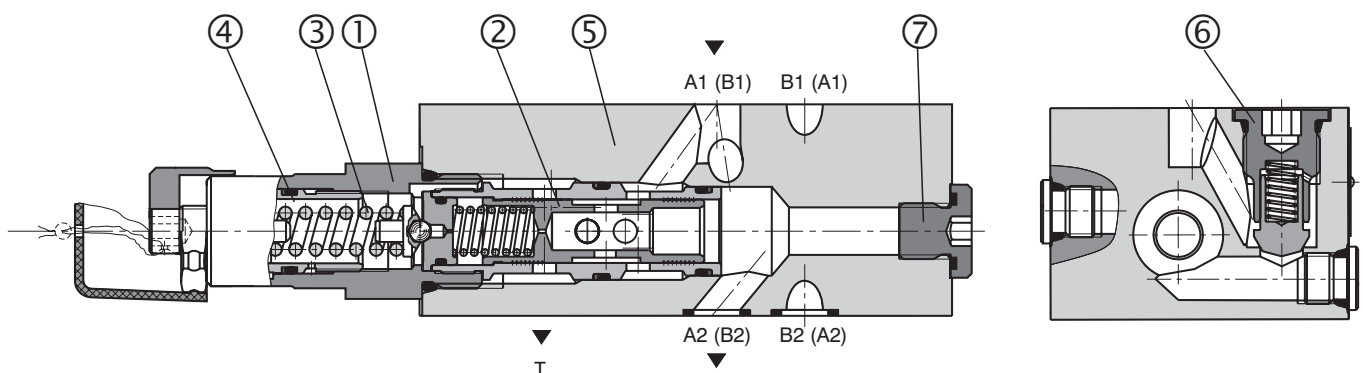

Ordering Code

VRN2-10/ -

Pilot Operated Pressure Reducing Valve

Nominal size

Model

screw in cartridge
 modular valve, pressure reduction in port A
 modular valve, pressure reduction in port B
 modular valve, pressure reduction in port P

S
MA
MB
MP

6
10
16
21

without designation
V

Sealing
 NBR
 Viton

Adjustment element
 screw with internal hexagon 6 mm
 hand knob

Pressure range
 up to 63 bar
 up to 100 bar
 up to 160 bar
 up to 210 bar

FOR PREFERRED TYPES SEE BOLD TYPING IN ORDERING CODE AND TABLE OF PREFERRED TYPES ON PAGE 7

Functional Symbols

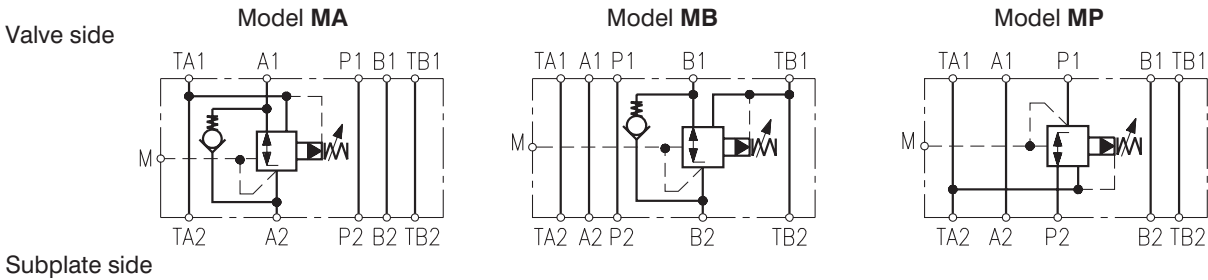

Ordering Numbers of Sandwich / Valve Bodies (without screw-in cartridge)

Valve body for modular valve - NBR	Ordering number	Valve body for modular valve - Viton	Ordering number
MA10-VR	15984300	MA10-VR/V	22909700
MB10-VR	15984400	MB10-VR/V	22909800
MP10-VR	15984500	MP10-VR/V	22909900

Technical Data

Nominal size	mm	10
Maximum flow rate - screw in cartridge	L/min	150
Maximum flow rate - modular valve	L/min	80
Maximum pilot flow	L/min	0.65
Max. input pressure (port P)	bar	320
Max. output pressure (port T)	bar	160
Working pressure related to flow	bar	see p-Q characteristics
Hydraulic fluid		Hydraulic oils of power classes (HL, HLP) to DIN 51524
Fluid temperature range (NBR)	°C	-30 ... +100
Fluid temperature range (Viton)	°C	-20 ... +120
Viscosity range	mm ² /s	20 ... 400
Maximum degree of fluid contamination		Class 21/18/15 according to ISO 4406
Weight: model S model MA, MB model MP	kg	0.35 3.20 2.85
Mounting position		unrestricted

p-Q Characteristics Screw in Cartridge

Measured at $v = 32 \text{ mm}^2/\text{s}$

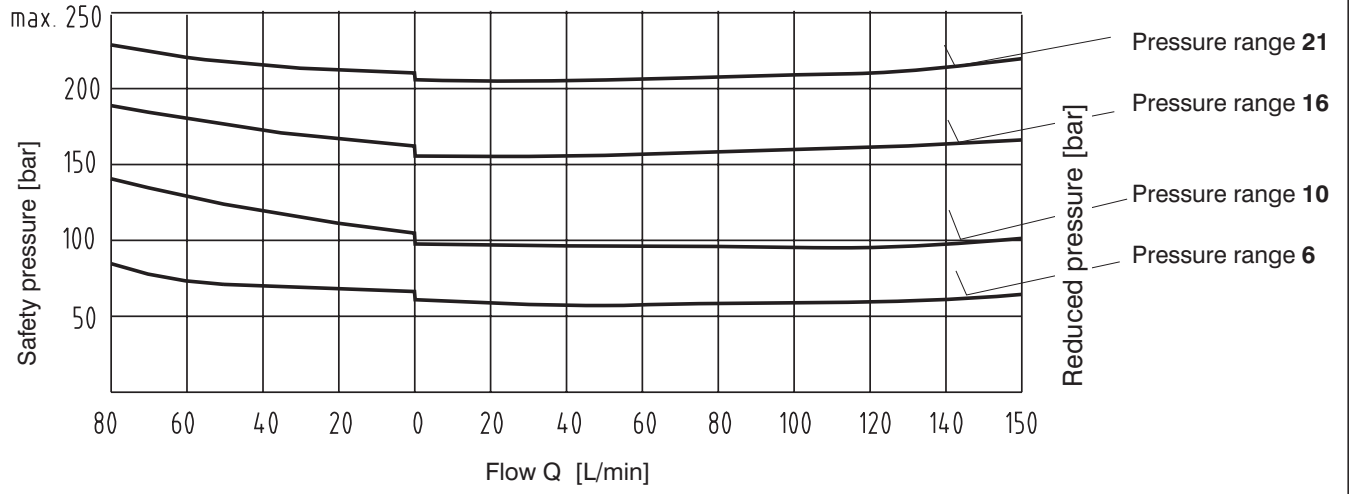

3

Δp -Q Characteristics Screw in Cartridge

Measured at $v = 32 \text{ mm}^2/\text{s}$

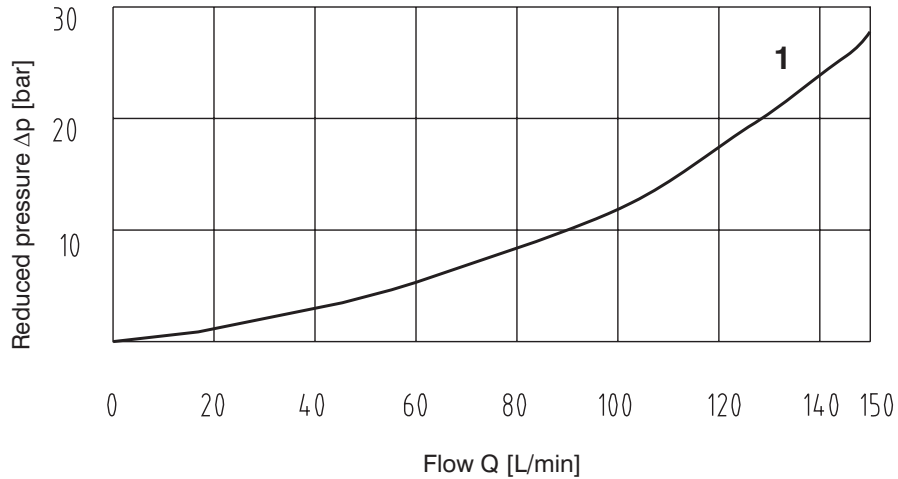

	Model	Direction
1	Model S	A - P

p-Q Characteristics Modular Valve

Measured at $v = 32 \text{ mm}^2/\text{s}$

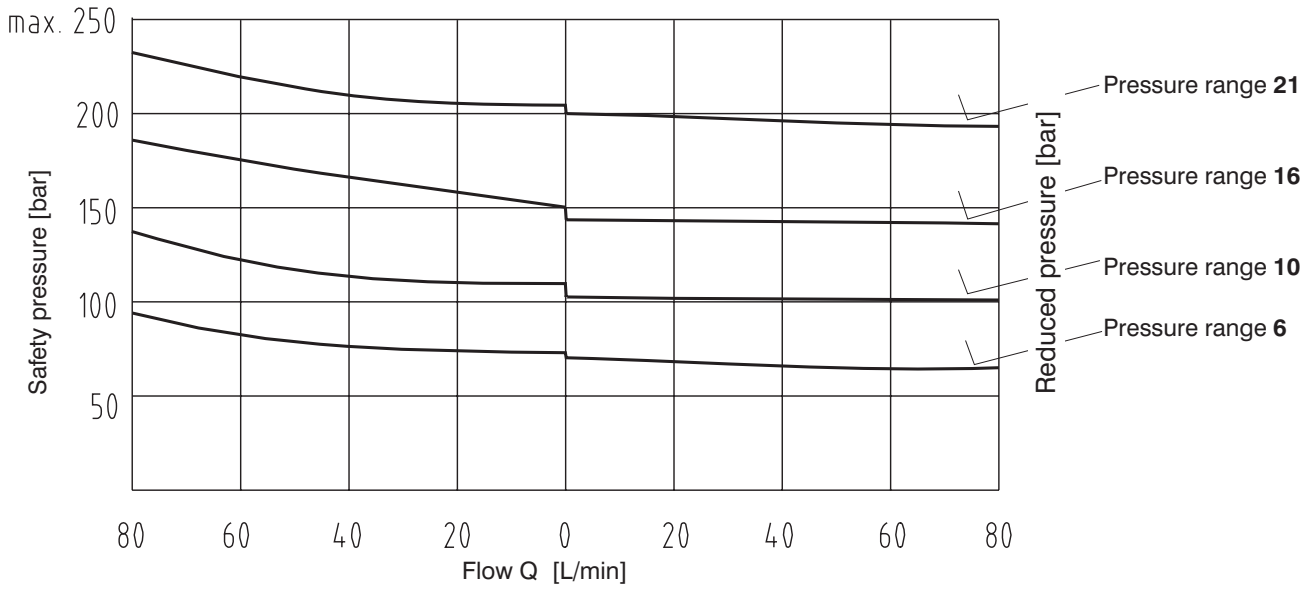

Δp -Q Characteristics Modular Valve

Measured at $v = 32 \text{ mm}^2/\text{s}$

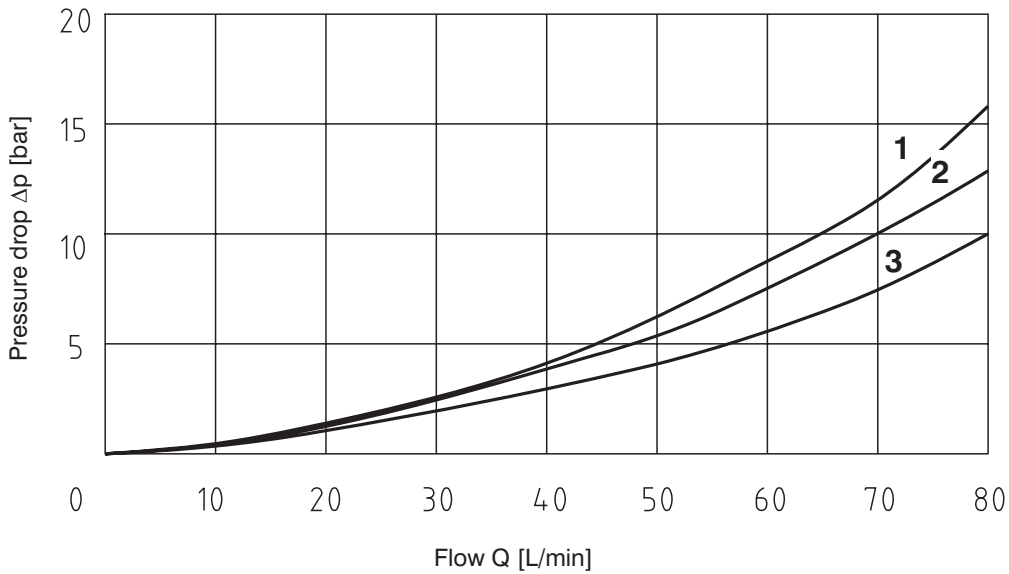

	Model	Direction
1	Model MA, MB	A1 - A2 (B1 - B2)
2	Model MP	P2 - P1
3	Model MA, MB	A2 - A1 (B2 - B1)

3

Valve Dimensions

Dimensions in millimeters

Model S

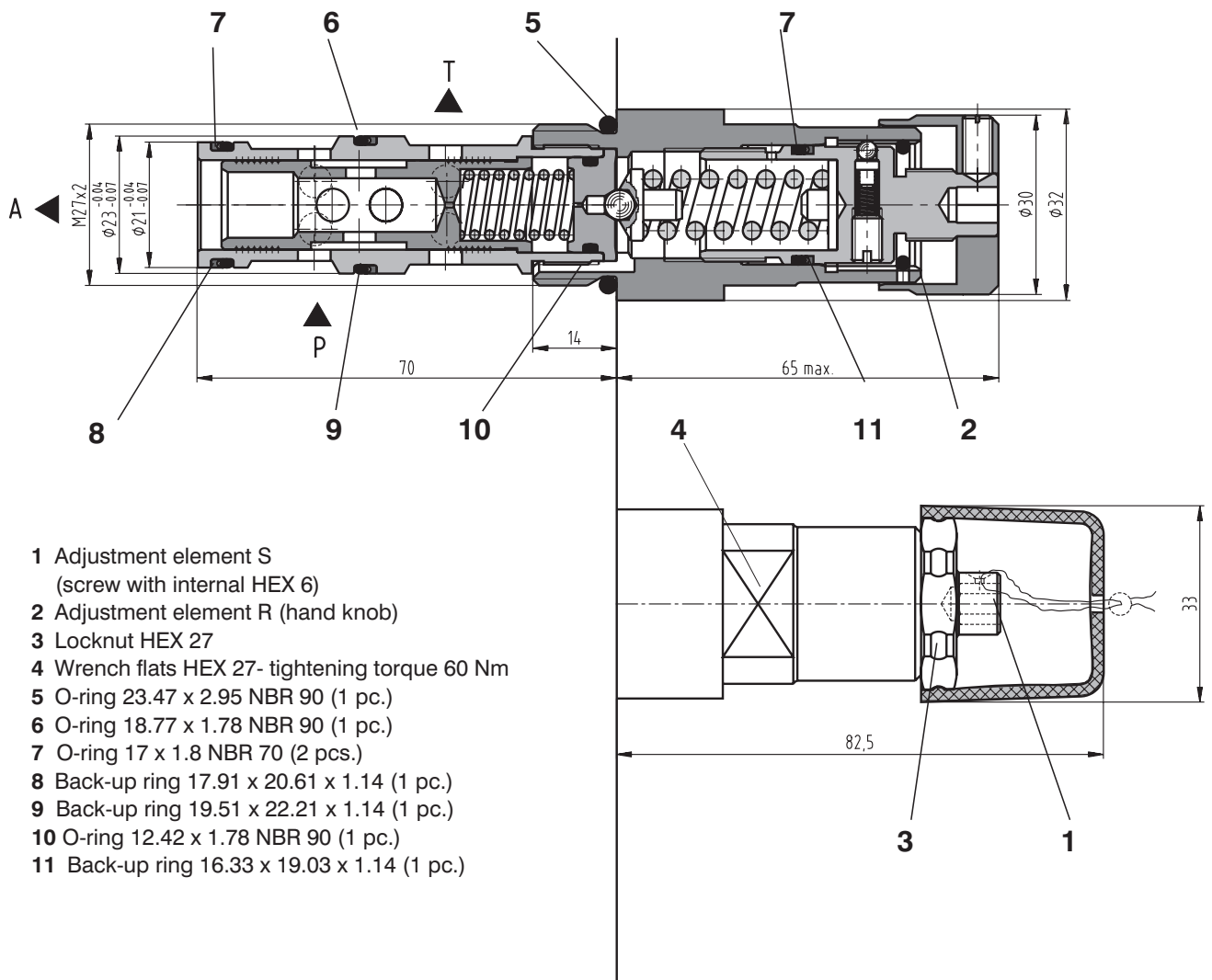

- 1 Adjustment element S
(screw with internal HEX 6)
- 2 Adjustment element R (hand knob)
- 3 Locknut HEX 27
- 4 Wrench flats HEX 27- tightening torque 60 Nm
- 5 O-ring 23.47 x 2.95 NBR 90 (1 pc.)
- 6 O-ring 18.77 x 1.78 NBR 90 (1 pc.)
- 7 O-ring 17 x 1.8 NBR 70 (2 pcs.)
- 8 Back-up ring 17.91 x 20.61 x 1.14 (1 pc.)
- 9 Back-up ring 19.51 x 22.21 x 1.14 (1 pc.)
- 10 O-ring 12.42 x 1.78 NBR 90 (1 pc.)
- 11 Back-up ring 16.33 x 19.03 x 1.14 (1 pc.)

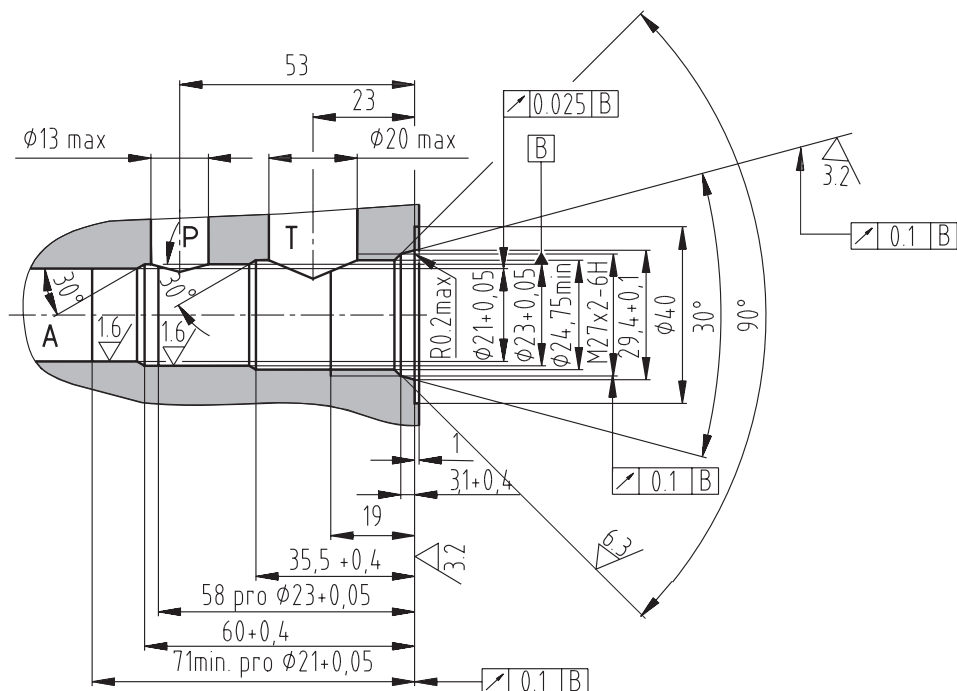

3

Valve Dimensions

Dimensions in millimeters

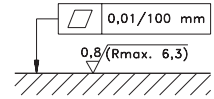

Required surface finish of interface

Model MA

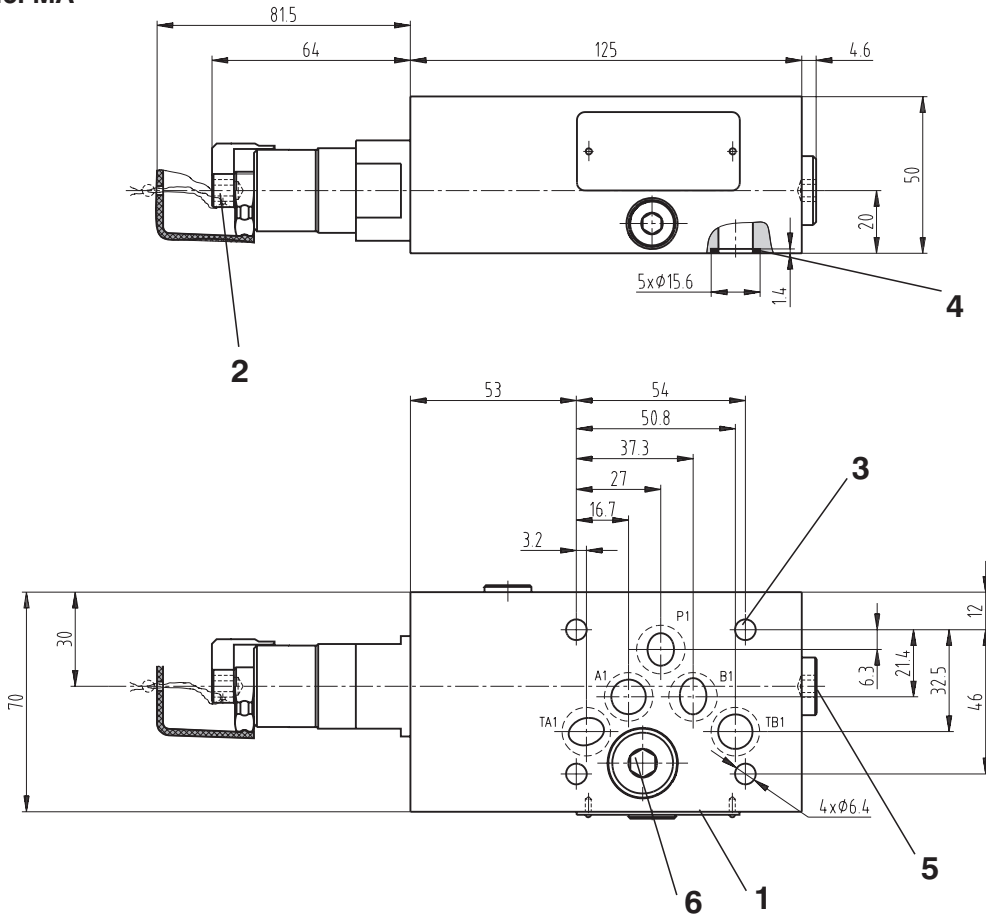

Model MB

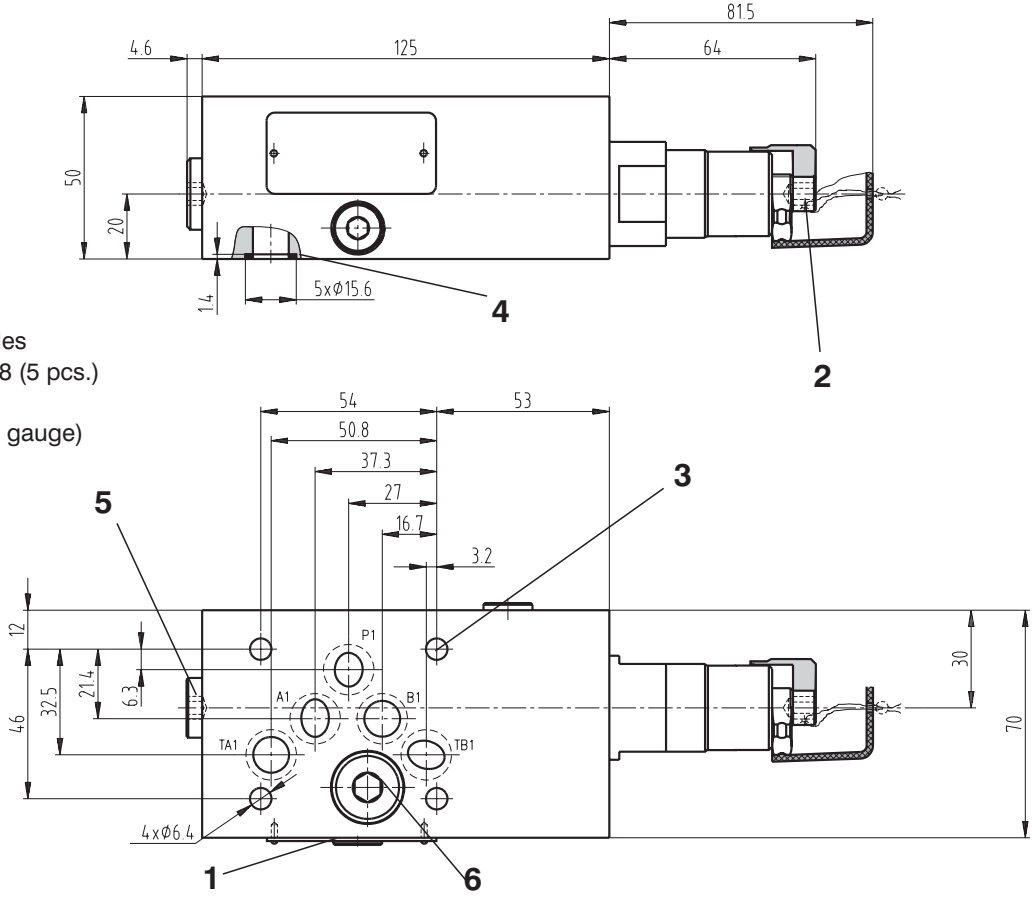

- 1 Name plate
- 2 Adjustment elements
- 3 4 through mounting holes
- 4 Square ring 12.42 x 1.68 (5 pcs.) supplied with valve
- 5 Plug G1/4 (for pressure gauge)
- 6 Check valve

Valve Dimensions

Dimensions in millimeters

Model MP

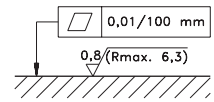

Required surface finish of interface

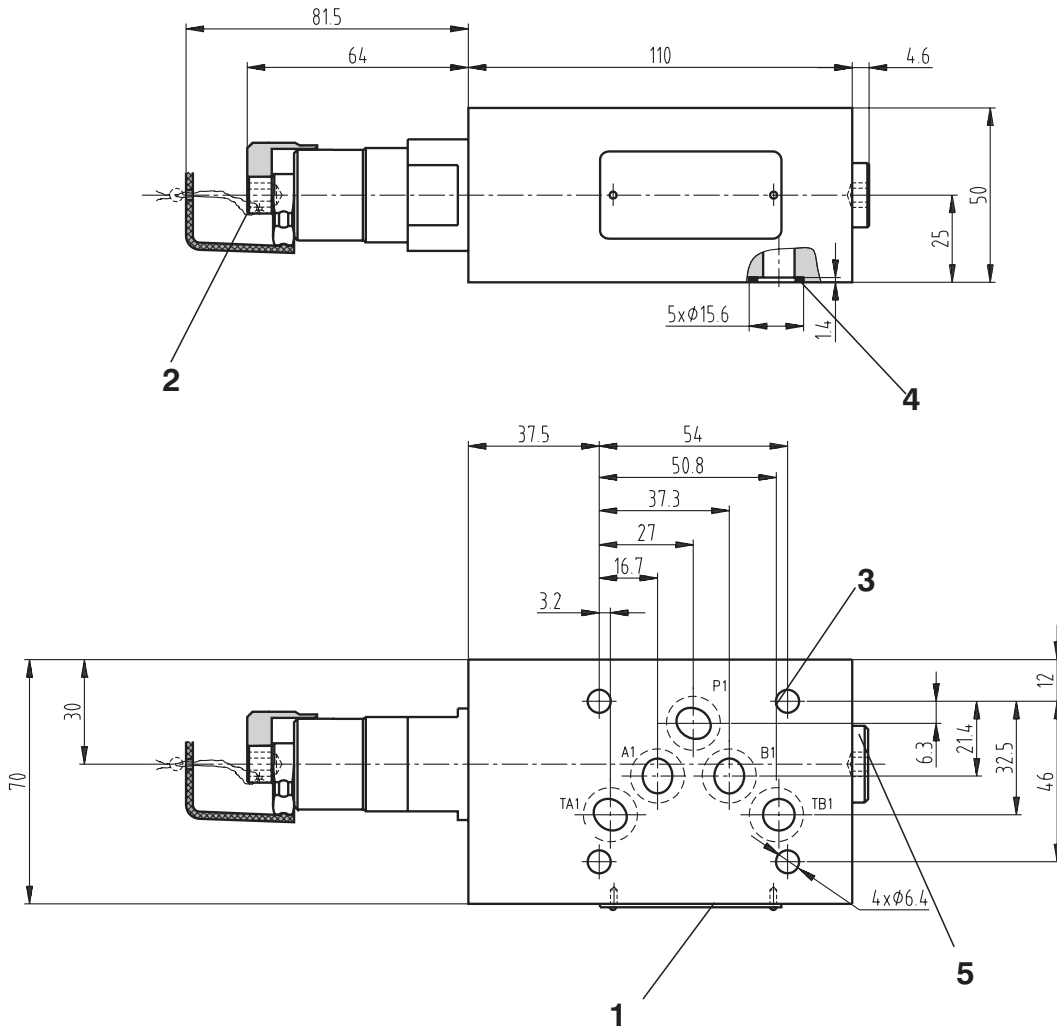

- 1 Name plate
- 2 Adjustment elements
- 3 4 through mounting holes
- 4 Square ring 12.42 x 1.68 (5 pcs.), supplied with valve
- 5 Plug G1/4 (for pressure gauge)

Preferred Types of Valves

Type	Ordering Number
VRN2-10/S-10S	15983800
VRN2-10/S-21S	15984000
VRN2-10/MP-10S	22915100
VRN2-10/MP-21S	15986200

Spare Parts - Seal Kits

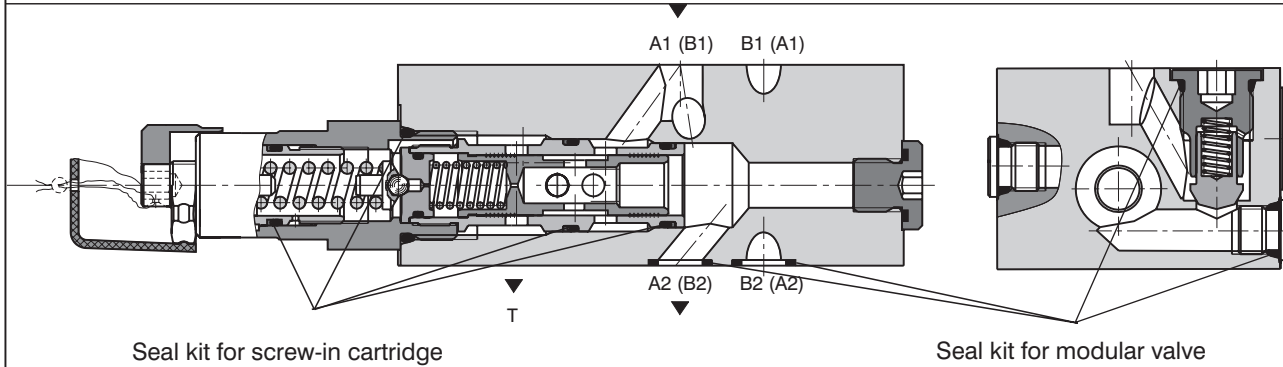

Seal kit for screw-in cartridge

Seal kit for modular valve

Model	Dimensions, quantity	Ordering number
Screw-in cartridge - NBR	O-ring 17 x 1.8 NBR 70 (2 pcs.)	22916600
	O-ring 12.42 x 1.78 NBR 90 (1 pc.)	
	O-ring 18.77 x 1.78 NBR 90 (1 pc.)	
	O-ring 23.47 x 2.95 NBR 90 (1 pc.)	
	Back-up ring BBP80B018N962N 19.51 x 22.21 x 1.14 (1 pc.)	
	Back-up ring BBP80B017N962N 17.91 x 20.61 x 1.14 (1 pc.)	
Screw-in cartridge - Viton	Back-up ring BBP80B016N9 16.33 x 19.03 x 1.14 (1 pc.)	22916700
	O-ring 17.17 x 1.78 (2 pcs.)	
	O-ring 12.42 x 1.78 (1 pc.)	
	O-ring 18.77 x 1.78 (1 pc.)	
	O-ring 23.47 x 2.95 (1 pc.)	
	Back-up ring BBP80B017V96E1 17.91 x 20.61 x 1.14 (1 pc.)	
Modular valve - NBR	Back-up ring BG1300174-PT00 17.4 x 20 x 1.4 (1 pc.)	22916800
	Back-up ring BBP80B018V9 19.51 x 22.21 x 1.14 (1 pc.)	
	O-ring 15.4 x 2.1 (1 pc.)	
	O-ring 10 x 1.8 (2 pcs.)	
	O-ring 17 x 1.8 (2 pcs.)	
	O-ring 12.42 x 1.78 (1 pc.)	
	O-ring 18.77 x 1.78 (1 pc.)	
	O-ring 23.47 x 2.95 (1 pc.)	
	Back-up ring BBP80B016N9 16.33 x 19.03 x 1.14 (1 pc.)	
Modular valve - Viton	Back-up ring BBP80B018N962N 19.51 x 22.21 x 1.14 (1 pc.)	22916900
	Back-up ring BBP80B017N962N 17.91 x 20.61 x 1.14 (1 pc.)	
	Square ring 12.42 x 1.68 (5 pcs.)	
	O-ring 15.4 x 2.1 (1 pc.)	
	O-ring 9.75 x 1.78 (2 pcs.)	
	O-ring 12.42 x 1.78 (6 pcs.)	
	O-ring 17.17 x 1.78 (2 pcs.)	
	O-ring 18.77 x 1.78 (1 pc.)	
	O-ring 23.47 x 2.95 (1 pc.)	
Back-up ring BBP80B017V96E1 17.91 x 20.61 x 1.14 (1 pc.)		
Back-up ring BG1300174-PT00 17.4 x 20 x 1.4 (1 pc.)		
Back-up ring BBP80B18-V9 19.51 x 22.21 x 1.14 (1 pc.)		

Caution!

- The packing foil is recyclable. The protecting plate can be returned to the manufacturer.
- The technical information regarding the product presented in this catalogue is for descriptive purposes only. It should not be construed in any case as a guaranteed representation of the product properties in the sense of the law.

ARGO-HYTOS s.r.o. CZ - 543 15 Vrchlaví
 Tel.: +420-499-403111, Fax: +420-499-403421
 E-mail: sales.cz@argo-hytos.com
 www.argo-hytos.com

- Screw-in cartridge design
- 5 pressure ranges
- Pressure setting by
 - Hexagon set screw lock
 - Adjustable handknob

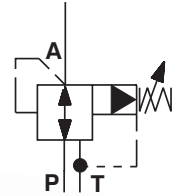

3

Functional Description

The pressure valves SP4A-B3 are pilot operated screw-in cartridge pressure reducing valves designed as 3 way valves, i.e. with pressure protection of the secondary circuit. The reducing valve consists of a body (1) with thread 7/8-14 UNF, control spool (2), spring (3) and the adjustment element (4). The flow from the primary circuit flows to the first metering edge, where its pressure is reduced. The reduced pressure corresponds with the adjustment of the control spring of the ball pilot valve (5). The reduced pressure is continuously controlled and compared with the pressure preset. If any control error appears, the respective control action takes place and the reduced pressure returns to its preset value. If

pressure behind the valve increases due to the effect of external load acting on the user, the control spool shifts further against the spring, the reducing metering edge closes and the second metering edge opens. The fluid passes through the „third way“ to port T. The control flow of the pilot valve (from the spring room) is also routed to port T.

The valve body and the adjustment screw are zinc coated.

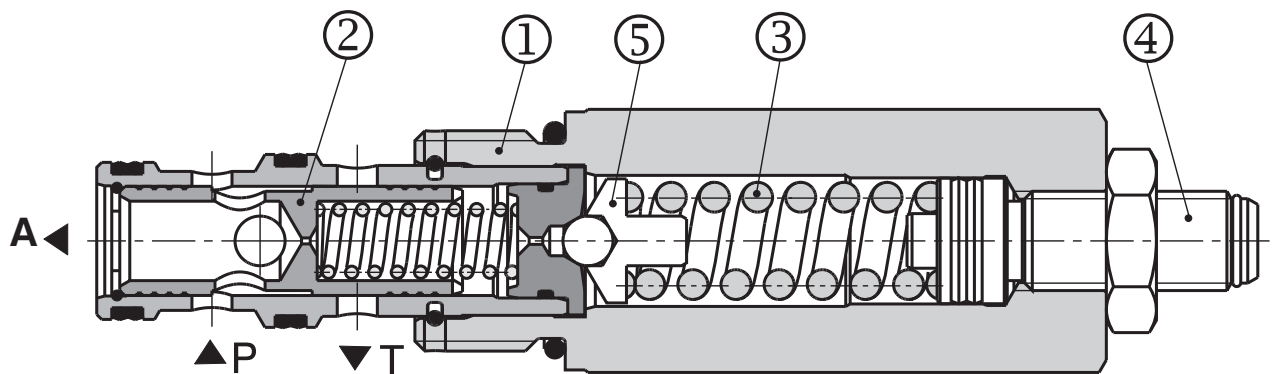

Ordering Code

SP4A-B3 /

Directly Operated Pressure Relief Valve
7/8-14 UNF

Standard **S**

Pressure range
 up to 63 bar (914 PSI) **6,3**
 up to 100 bar (1450 PSI) **10**
 up to 160 bar (2320 PSI) **16**
 up to 250 bar (3626 PSI) **25**
 up to 350 bar (5076 PSI) **35**

without designation
V

Seals
NBR
FPM (Viton)

S
R

Adjustment option
Hexagon set screw locknut 5 mm
Adjustable handknob

Technical Data

Valve size		B3
Cartridge thread		7/8-14 UNF-2A
Max. flow rate	L/min (GPM)	60 (15.85)
Max. input pressure (port P)	bar (PSI)	350 (5076)
Max. output pressure (port T)	bar (PSI)	100 (1450)
Working pressure related to flow	bar (PSI)	see p-Q characteristics
Hydraulic fluid		Hydraulic oils of power classes (HL, HLP) to DIN 51524
Fluid temperature range for standard (NBR)	°C (°F)	-30 ... +100 (-22 ... 212)
Fluid temperature range for Viton (FPM)	°C (°F)	-20 ... +120 (-4 ... 248)
Viscosity range	mm ² /s (SUS)	10 ... 500 (49 ... 2450)
Max. degree of fluid contamination		Class 21/18/15 according to ISO 4406
Weight	kg (lbs)	0.24 (0.53)
Maximum valve tightening torque	Nm (lbf.ft)	35+5 (25.8+3.7)
Mounting position		unrestricted
Valve body (data sheet HA 0018)		SB-B3

p-Q Characteristics

Measured at $v = 32 \text{ mm}^2/\text{s}$ (156 SUS)

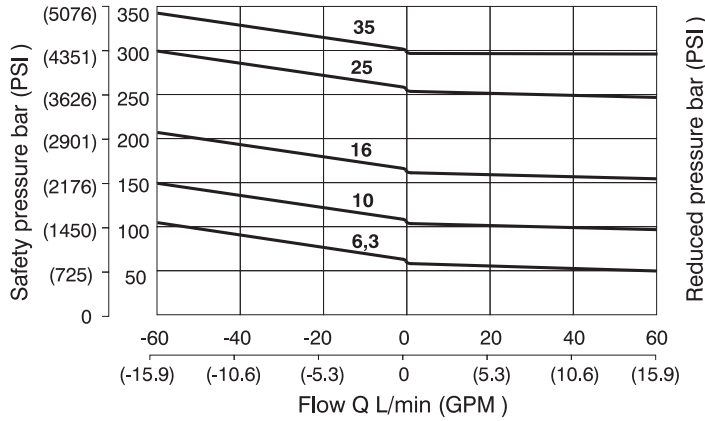

Δp -Q Characteristic

Measured at $v = 32 \text{ mm}^2/\text{s}$ (156 SUS)

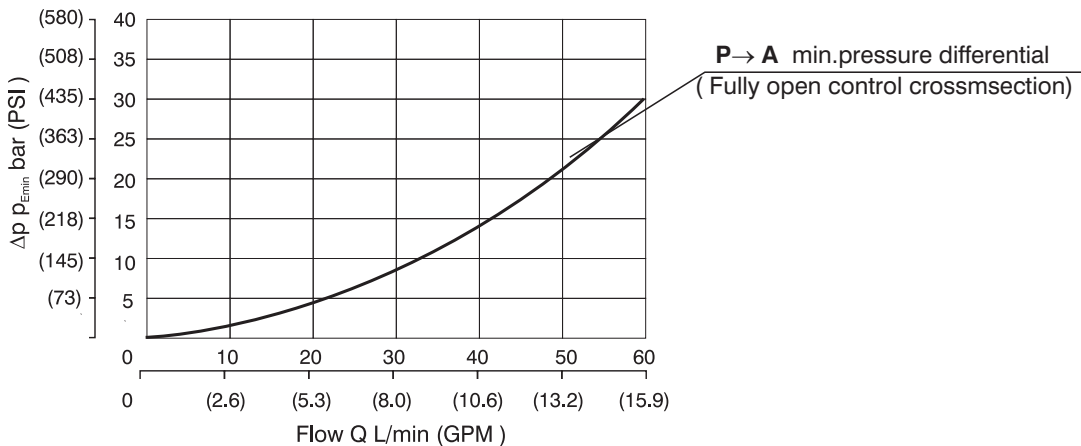

Valve Dimensions

Dimensions in millimeters (inches)

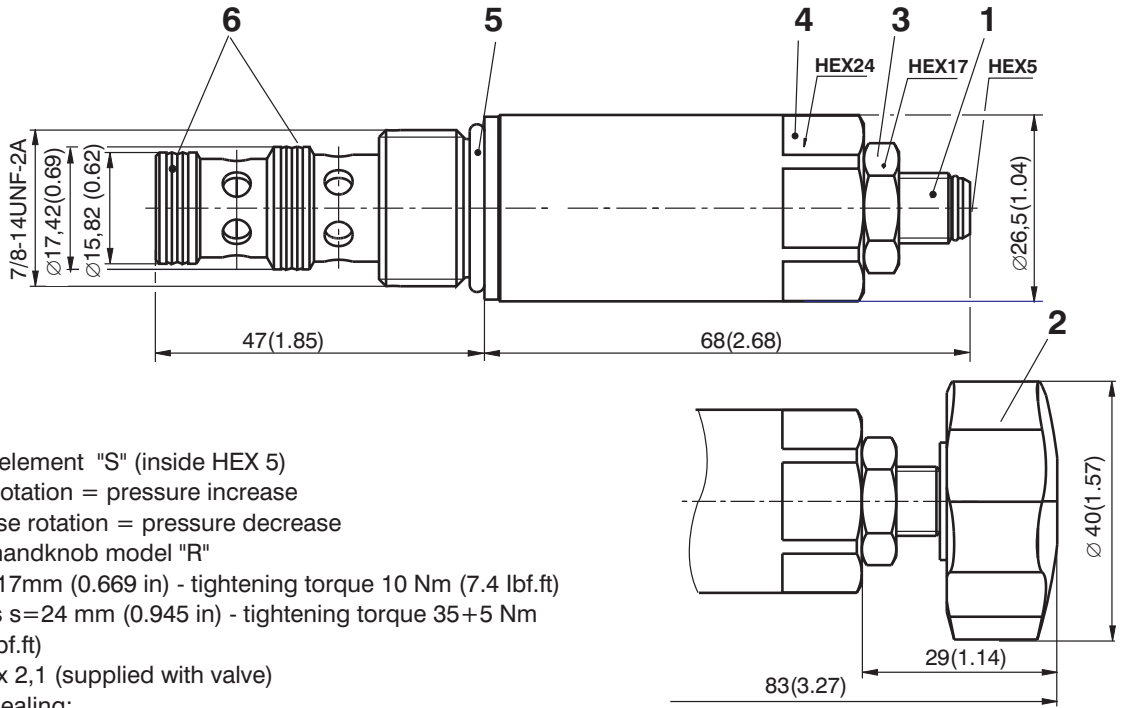

- 1 Adjustment element "S" (inside HEX 5)
 Clockwise rotation = pressure increase
 Anticlockwise rotation = pressure decrease
- 2 Adjustable handknob model "R"
- 3 Locknut s=17mm (0.669 in) - tightening torque 10 Nm (7.4 lbf.ft)
- 4 Wrench flats s=24 mm (0.945 in) - tightening torque 35+5 Nm (25.8+3.7 lbf.ft)
- 5 O-ring 19,4 x 2,1 (supplied with valve)
- 6 Combined sealing:
 DRYZ000002Z20 13,47 x 15,87 x 3,1
 DUYZ000001Z20 17,47 x 15,07 x 3,1 (supplied with valve)

Cavity

Dimensions in millimeters (inches)

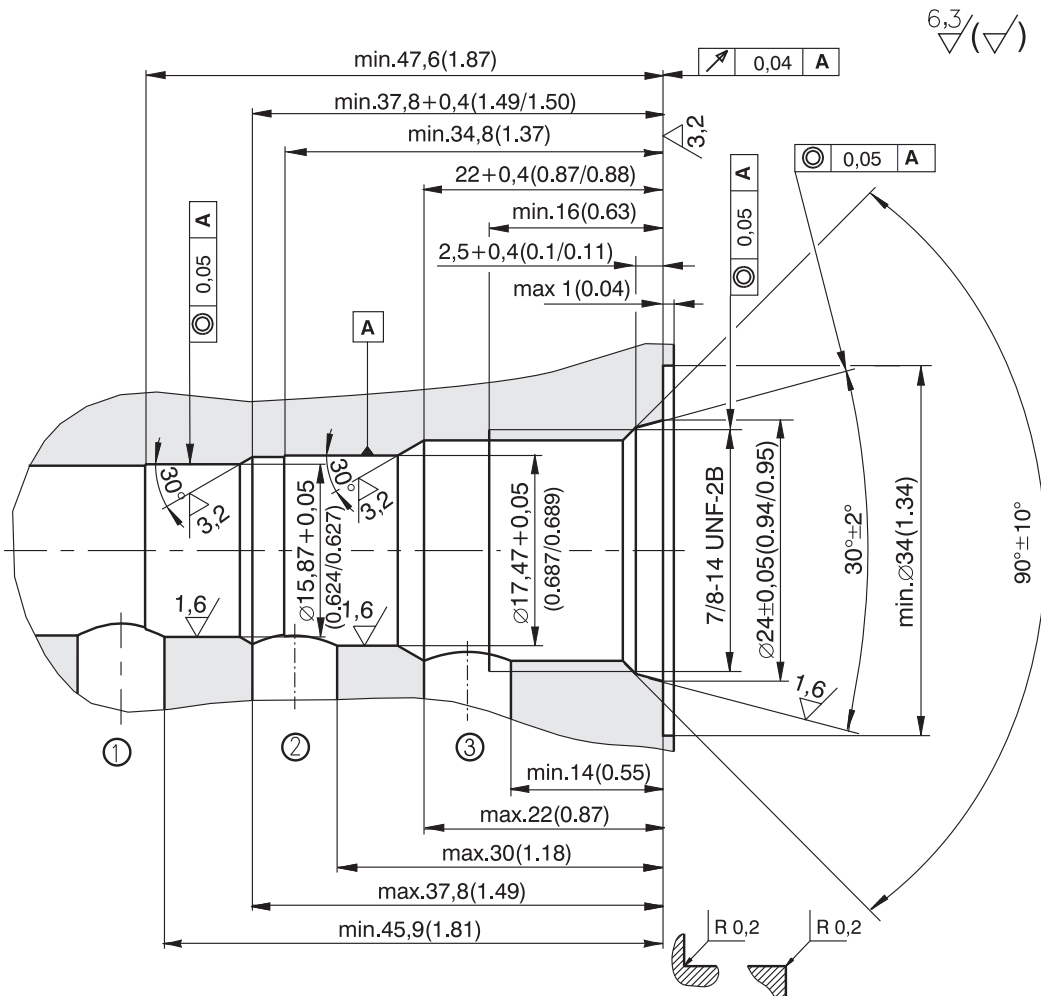

Spare Parts

Seal kit

Dualseal - PU	O-ring - Viton	Ordering number
DRYZ000002Z20 13,47 x 15,87 x 3,1 (1pc.)	19,4 x 2,1 (1pc.)	18775700
DUYZ000001Z20 17,47 x 15,07 x 3,1 (1pc.)	-	

3

Caution!

- The packing foil is recyclable.
- The technical information regarding the product presented in this catalogue is for descriptive purposes only. It should not be construed in any case as a guaranteed representation of the product properties in the sense of the law.

ARGO-HYTOS s.r.o. CZ - 543 15 Vrchlabí
 Tel.: +420-499-403 111
 E-mail: info.cz@argo-hytos.com
 www.argo-hytos.com

- Compact design
- High pressure capabilities
- Cartridge model – built into the mounting cavity with the seat in manifold
- Factory set pressure setting
- Simple mounting – the valve and the screw plug build up an integral unit

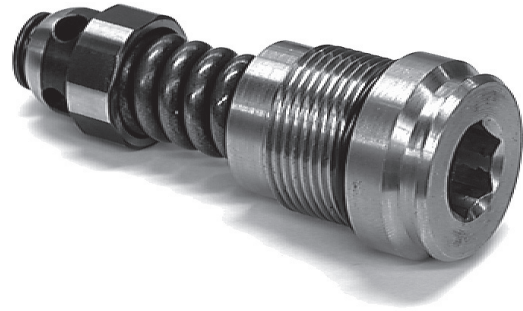
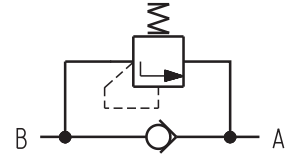

Functional Description

The high-pressure relief-check valve DBV2-420 is delivered as a cartridge unit without bushing, i.e. for direct mounting into the cavity with the seat machined directly in the manifold. In the direction A-B the fluid passes freely through the check valve (1). The direction B-A is closed by main seat (2) and as the pressure

increases above the factory set value the fluid is drained through the seat of the main cone (3). The adjusted pressure is defined as the pressure, which is necessary to open the relief valve at the flow rate 20 L/min (5.28 GPM).

The valve is delivered without any surface treatment.

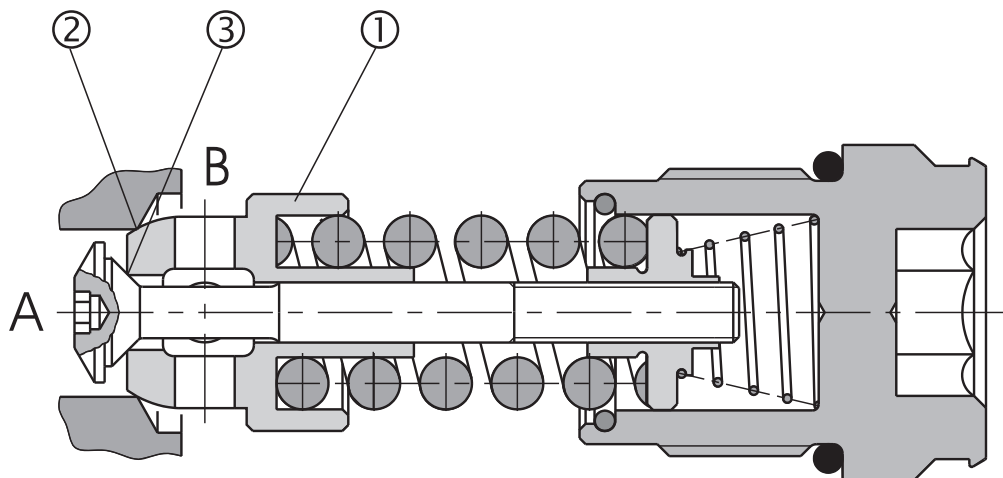

Ordering Code

DBV2 - 420

Combined Relief-Check Valves

Pressure
adjusted pressure 420 bar (6092 PSI)

3

Technical Data

Nominal size		10
Maximum flow rate	L/min (GPM)	200 (52.84)
Nominal pressure	bar (PSI)	420+15 (6091+218)
Pressure losses	bar (PSI)	see the characteristics
Hydraulic fluid		Hydraulic oils of power classes (HL, HLP) to DIN 51 524
Fluid temperature range	°C (°F)	-30 ... +100 (-22 ... +212)
Viscosity range	mm ² /s (SUS)	20 ... 400 (97.3 ... 1840)
Maximum degree of fluid contamination		Class 21/18/15 to ISO 4406
Weight	kg (lbs)	0,138 (0.300)
Mounting position		unrestricted

p-Q Characteristics

Measured at $v = 32 \text{ mm}^2/\text{s}$ (156 SUS)

Pressure Relief Valve, flow direction B → A
Static characteristic

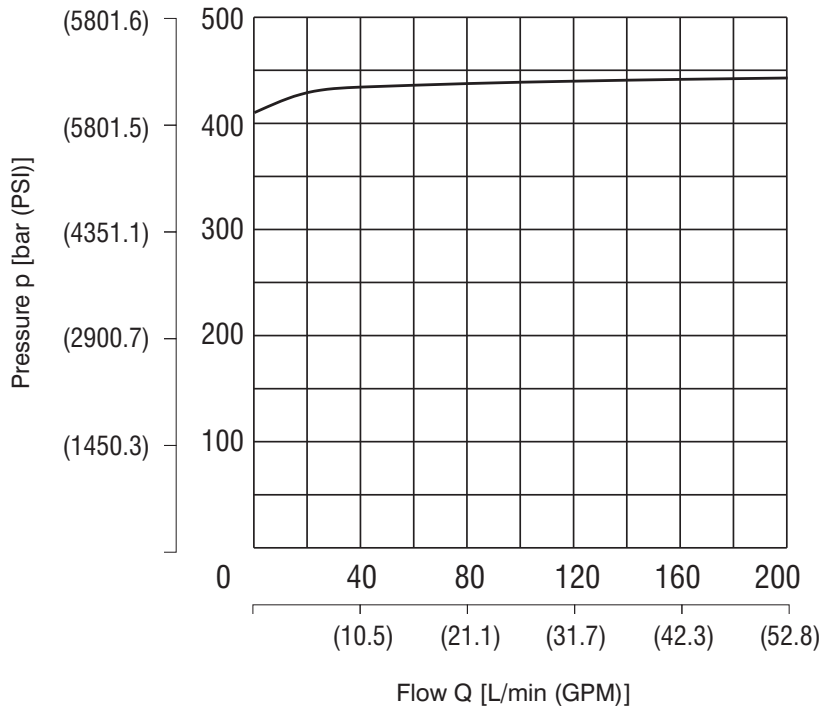

Δp-Q Characteristics

Measured at $v = 32 \text{ mm}^2/\text{s}$ (156 SUS)

Check Valve, flow direction A → B
Pressure drop of the check valve alone, measure at test manifold.

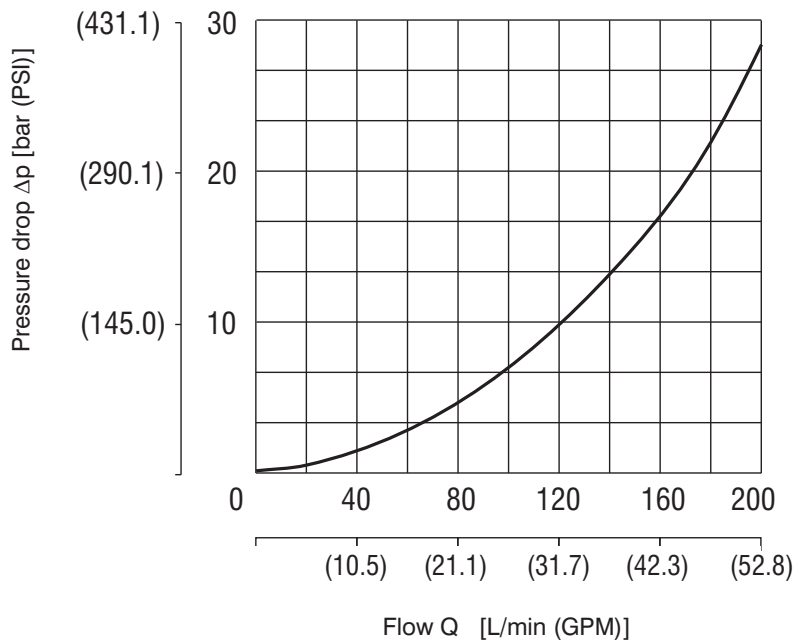

3

Valve Dimensions

Dimensions in millimeters (inches)

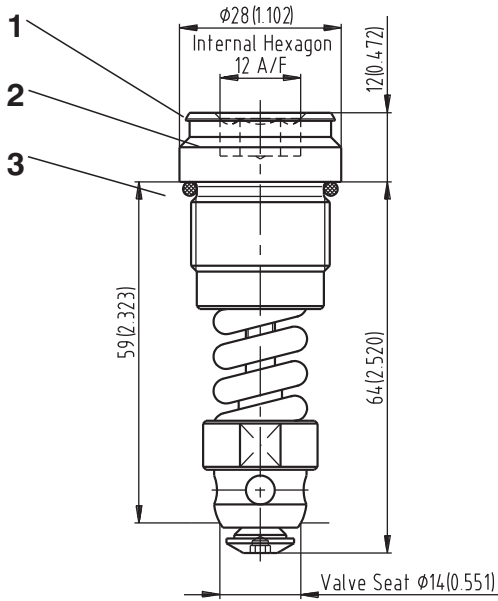

- 1 Nominal pressure
- 2 Inside hexagon for valve mounting into the cavity
Tightening torque 50 + 10 Nm (36.97 + 7.37 ft-lbs)
- 3 Seals: O-Ring 20.35 x 1.78
(supplied with valve)

Cavity

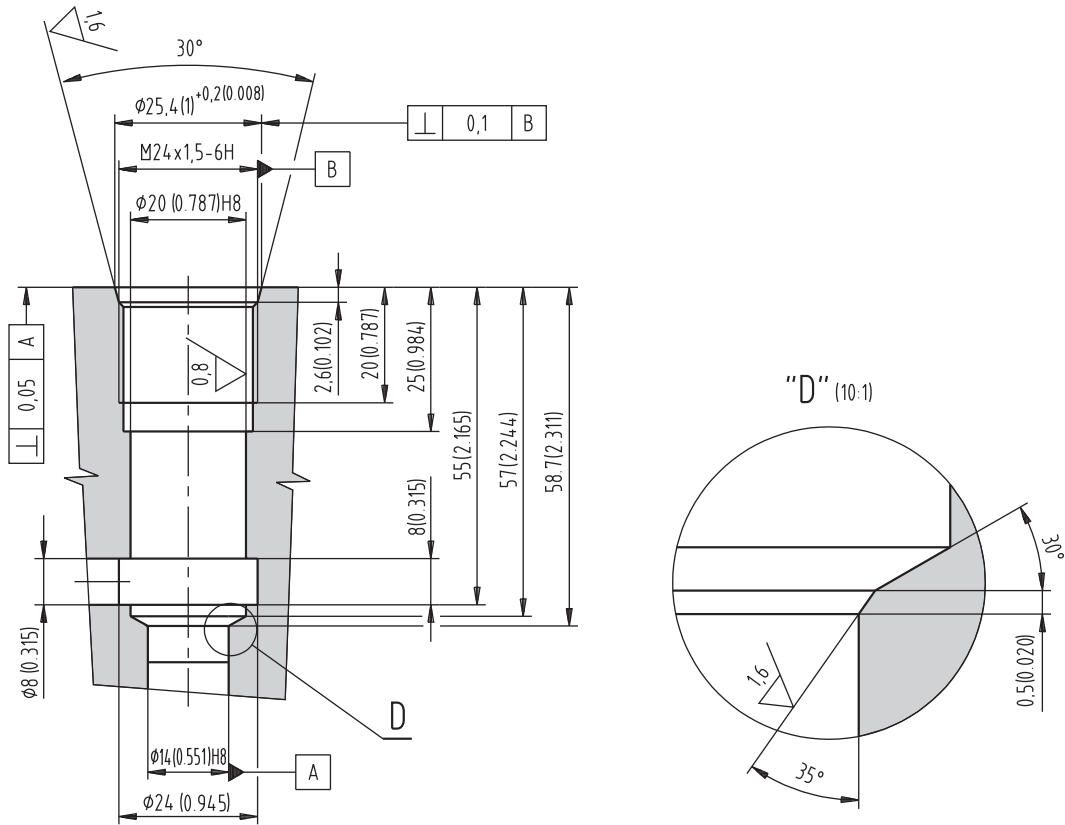

Caution!

- The packing foil is recyclable.
- The technical information regarding the product presented in this catalogue is for descriptive purposes only. It should not be construed in any case as a guaranteed representation of the product properties in the sense of the law.

ARGO-HYTOS s.r.o. CZ - 543 15 Vrchlaví
 Tel.: +420-499-403111, Fax: +420-499-403421
 E-mail: sales.cz@argo-hytos.com
 www.argo-hytos.com

- May be used as accumulator charging valve
- For unloading a high flow – low pressure pump to tank.

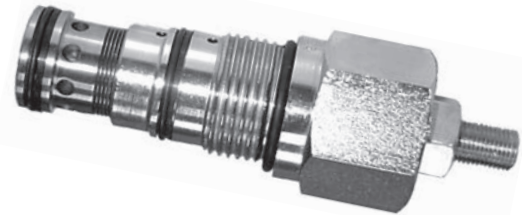
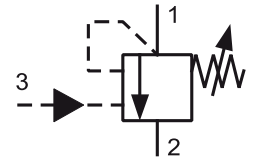

Functional Description

The valve consists of a ball control stage with a common drain into the storage tank, a main stage with a gate valve and a switching stage consisting of a bushing and a control gate valve. It is built-in in a secondary line in view of the feeding line. At the same time connections (1) and (3) are connected to the feeding line however they are separated mutually with the use of a one-way valve. For channel (1) on the side of the pump and channel (3) on the side of the system see page No 4.

The pressure in channel (1) acts through the nozzle hole in the longitudinal axis of the main gate valve also on its side loaded by the spring and through another nozzle hole in the switching stage to the control valve ball. As soon as this pressure exceeds a preset value of the spring force the ball is lifted from its seat and the control oil flows out to the storage tank. As a result of pressure difference the main gate valve is shifted against weak spring and the flow into the side channel (2) is released in this way.

The system pressure in channel (3) acting through the nozzle hole to the control gate valve prevents the control, stage from being shut off. The action of this pressure results in shifting the control gate valve in the direction against the ball of the control stage and in maintaining the ball in the lifted position from the seat. As soon as the system pressure drops to a value of 85% corresponding to the percentage to a ratio of areas of the control stage valve ball seat and the control gate valve the control stage and the main stage are shut off again and a new cycle can start.

As for appropriate basic surface finish the external parts are zinc coated.

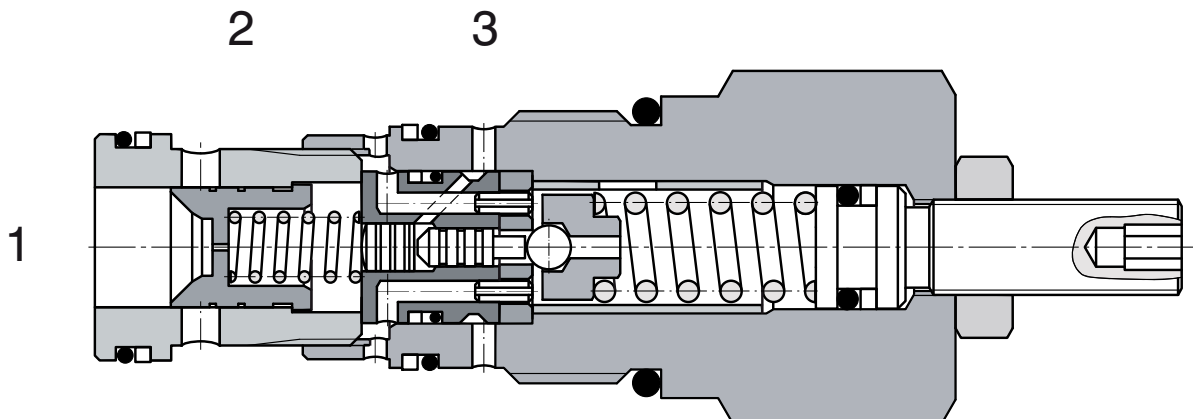

Ordering Code

SU6A-U3/I



Pilot Operated Unloading Valve

no designation

Seals
NBR

Adjustable pressure

40 - 100 bar	10
70 - 200 bar	20
150 - 350 bar	35

Technical Data

Cavity		1-1/8-12 UNF-2A
Maximum flow	L/min	60
Max. pressure	bar	350
Differential unload/reload	%	10 - 15
Hydraulic fluid		Hydraulic oil (HM, HV) according to DIN 51524
Fluid temperature range	°C	-20 ... +90
Viscosity	mm ² /s	20 ... 400
Maximum degree of fluid contamination		According to ISO 4406, Class 21/18/15
Weight	kg	0.46
Maximum valve tightening torque in valve body or in control block	Nm	75 ⁺²
Mounting position		unrestricted

p-Q Characteristics

Measured at $\nu = 40 \text{ mm}^2/\text{s}$

Typical valve performance

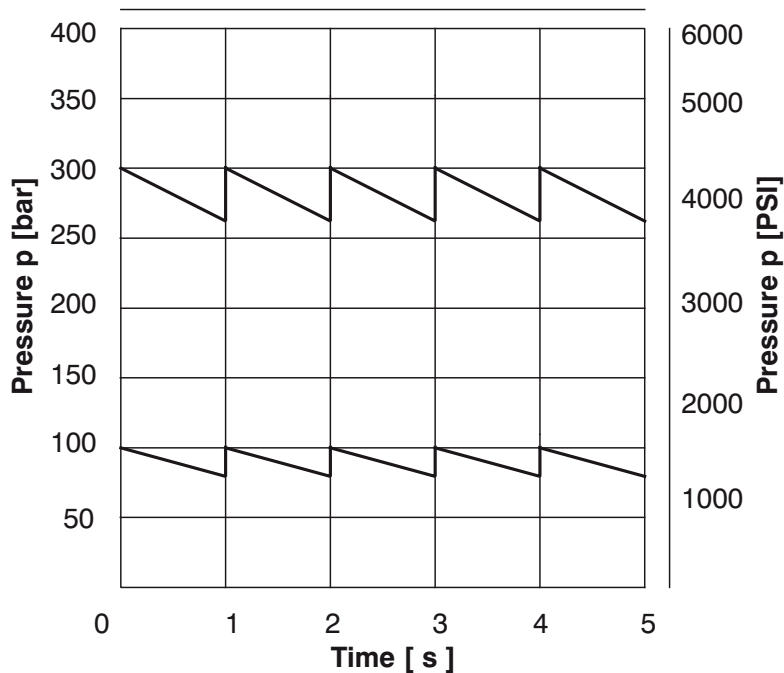

Dimensions

Measurements in millimeters

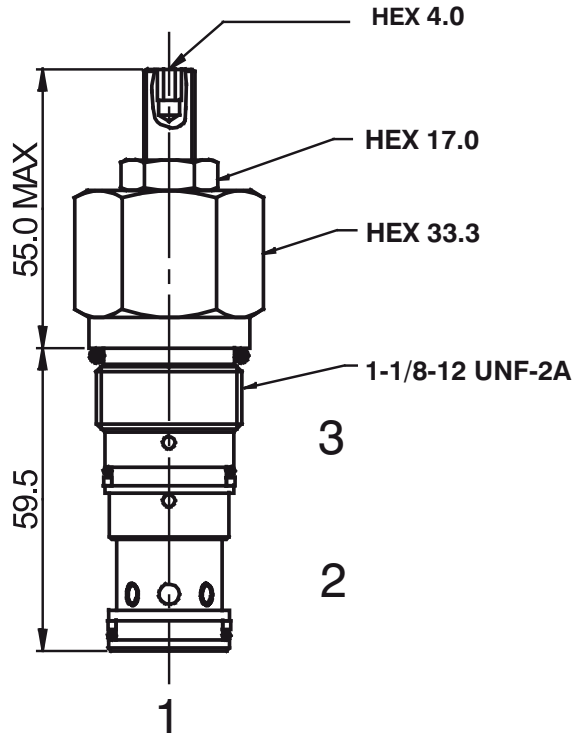

Cavity

Measurements in millimeters

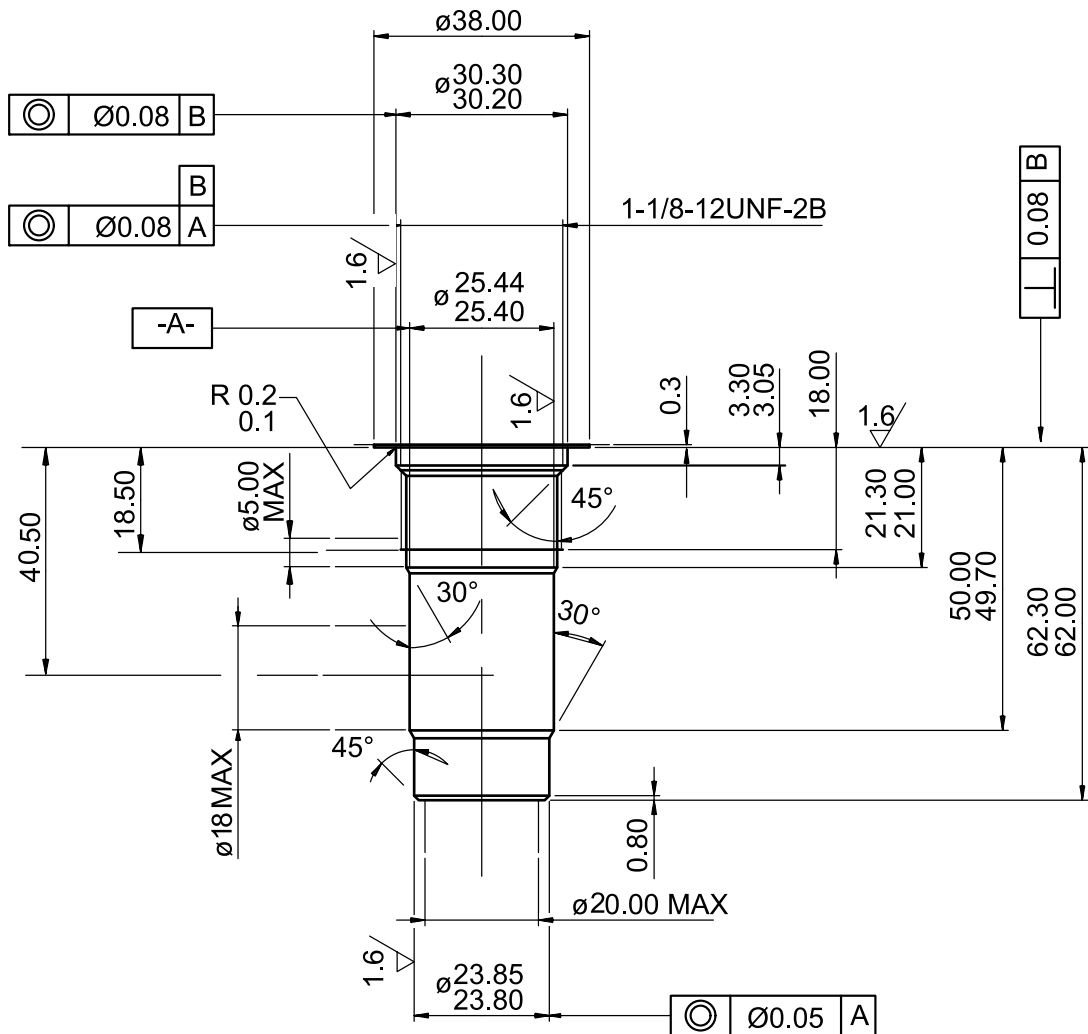

Valve Bodies

Measurements in millimeters

ISO A

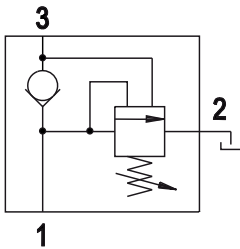
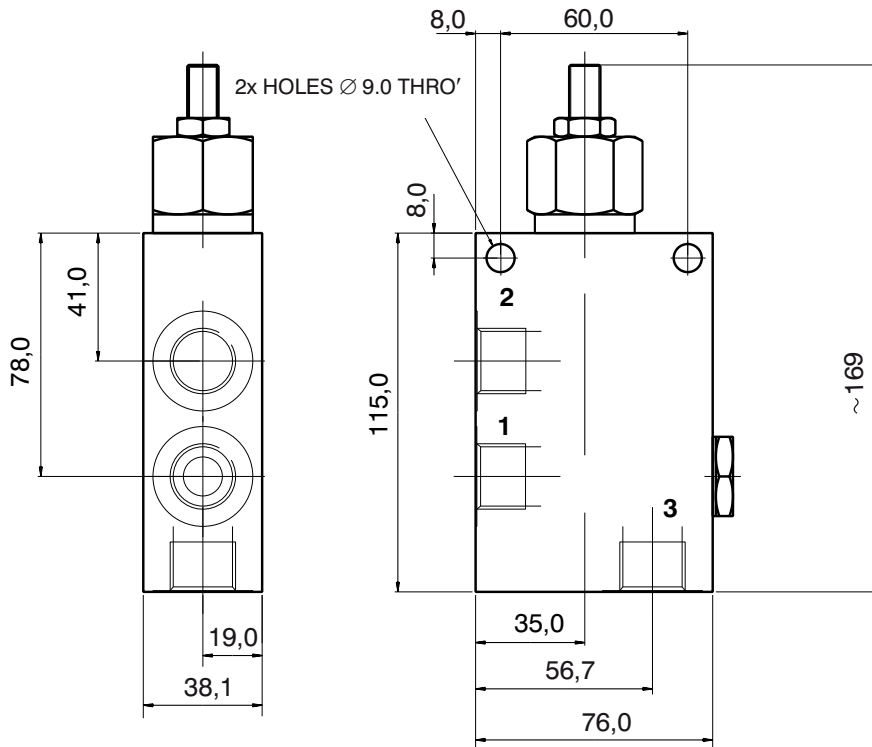
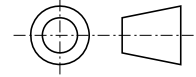

Body without valve			
Material	Ports	Port size	Type code
Aluminium	1, 2, 3	G1/2	SB-U3-0105AL
	1, 2, 3	SAE10, 7/8-14	SB-U3-0106AL
Steel	1, 2, 3	G1/2	SB-U3-0105ST
	1, 2, 3	SAE10, 7/8-14	SB-U3-0106ST

The use of aluminium bodies is limited to a maximum operating pressure of 210 bar.

Spare Parts

Seal kits on request.

Caution!

- The packing foil is recyclable.
- The technical information regarding the product presented in this catalogue is for descriptive purposes only. It should not be construed in any case as a guaranteed representation of the product properties in the sense of the law.

ARGO-HYTOS s.r.o. CZ - 543 15 Vrchlaví
 Tel.: +420-499-403111, Fax: +420-499-403421
 E-mail: sales.cz@argo-hytos.com
 www.argo-hytos.com

- May be used as accumulator charging valve
- For unloading a high flow – low pressure pump to tank.

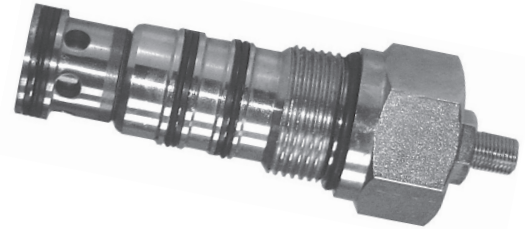
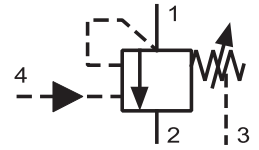

Functional Description

The valve consists of a ball control stage with a common drain into the storage tank, a main stage with a gate valve and a switching stage consisting of a bushing and a control gate valve. It is built-in in a secondary line in view of the feeding line. At the same time connections (1) and (4) are connected to the feeding line however they are separated mutually with the use of a one-way valve. For channel (1) on the side of the pump and channel (4) on the side of the system see page No 4.

The pressure in channel (1) acts through the nozzle hole in the longitudinal axis of the main gate valve also on its side loaded by the spring and through another nozzle hole in the switching stage to the control valve ball. As soon as this pressure exceeds a preset value of the spring force the ball is lifted from its seat and the control oil flows out to the storage tank. As a result of pressure difference the main gate valve is shifted against weak spring and the flow into the side channel (2) is released in this way.

The system pressure in channel (4) acting through the nozzle hole to the control gate valve prevents the control, stage from being shut off. The action of this pressure results in shifting the control gate valve in the direction against the ball of the control stage and in maintaining the ball in the lifted position from the seat. As soon as the system pressure drops to a value of 85% corresponding to the percentage to a ratio of areas of the control stage valve ball seat and the control gate valve the control stage and the main stage are shut off again and a new cycle can start.

As for appropriate basic surface finish the external parts are zinc coated.

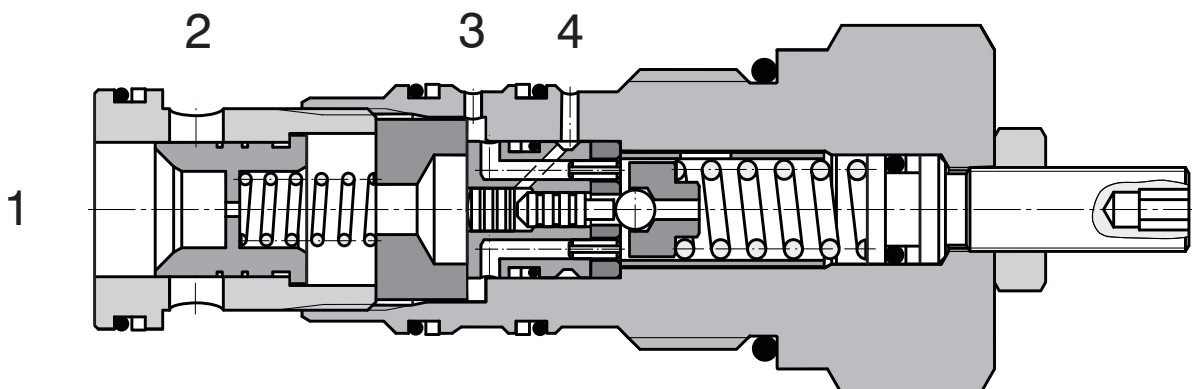

Ordering Code

SUD6A-V4/I

**Pilot Operated Priority
Unloading Valve**

no designation

**Seals
NBR**

Adjustable pressure

30 - 200 bar
150 - 350 bar

**20
35**

3

Technical Data

Cavity		1-5/16-12 UNS
Maximum flow	L/min	200
Max. pressure	bar	350
Differential unload/reload	%	10 - 15
Hydraulic fluid		Hydraulic oil (HM, HV) according to DIN 51524
Fluid temperature range	°C	-20 ... +90
Viscosity	mm ² /s	20 ... 400
Maximum degree of fluid contamination		According to ISO 4406, Class 21/18/15
Weight	kg	0.74
Maximum valve tightening torque in valve body or in control block	Nm	100 ⁺²
Mounting position		Unrestricted

p-Q Characteristics

Measured at $v = 40 \text{ mm}^2/\text{s}$

Typical valve performance

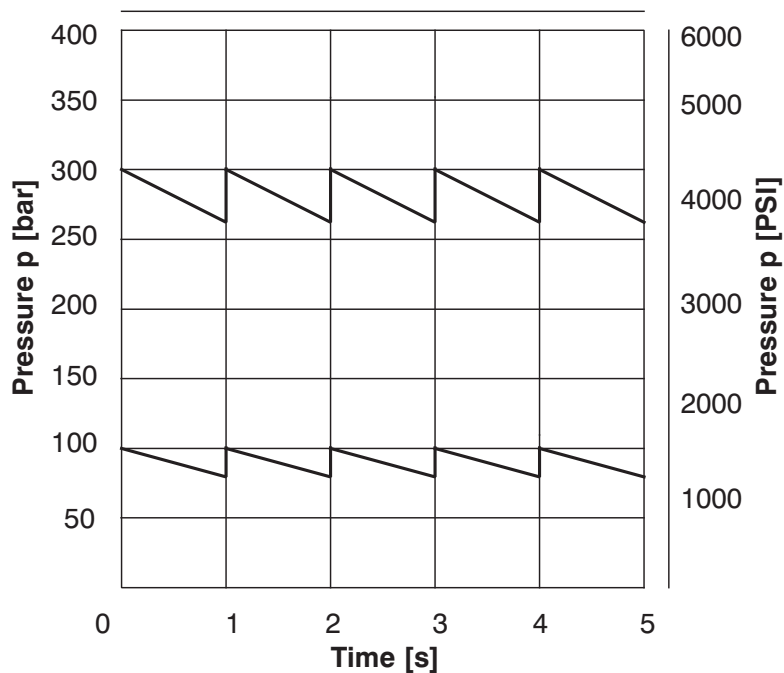

Dimensions

Measurements in millimeters

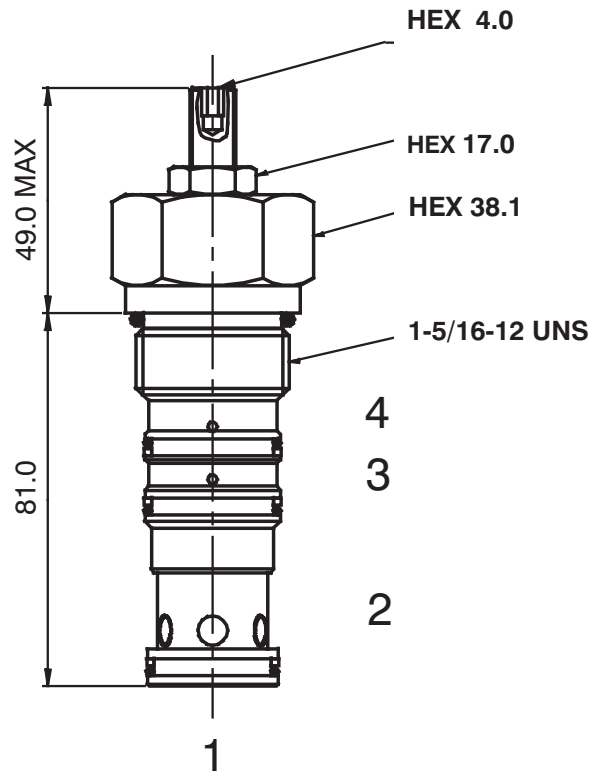

Cavity

Measurements in millimeters

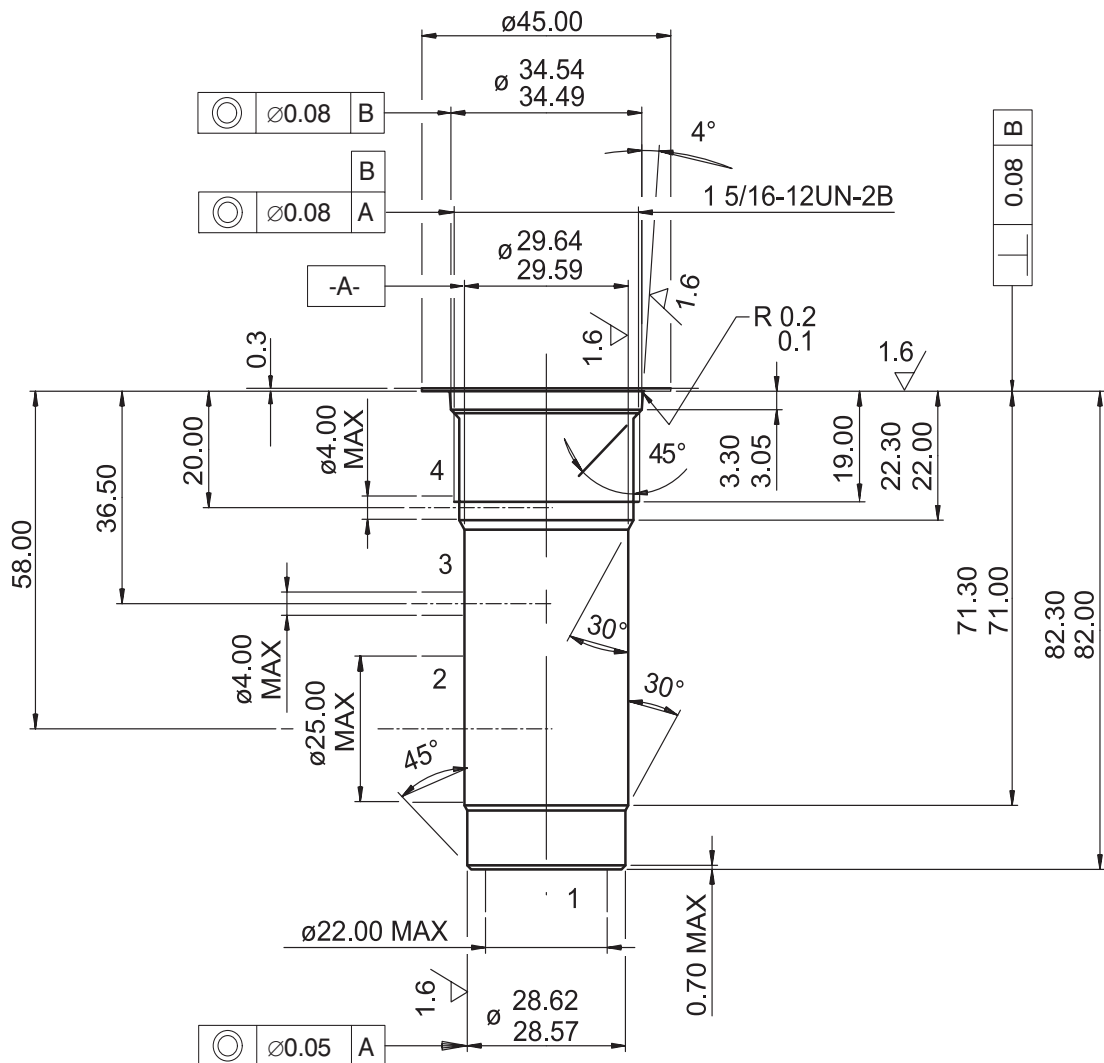

Valve Bodies

Measurements in millimeters

ISO A

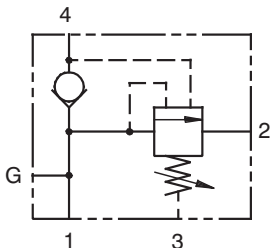
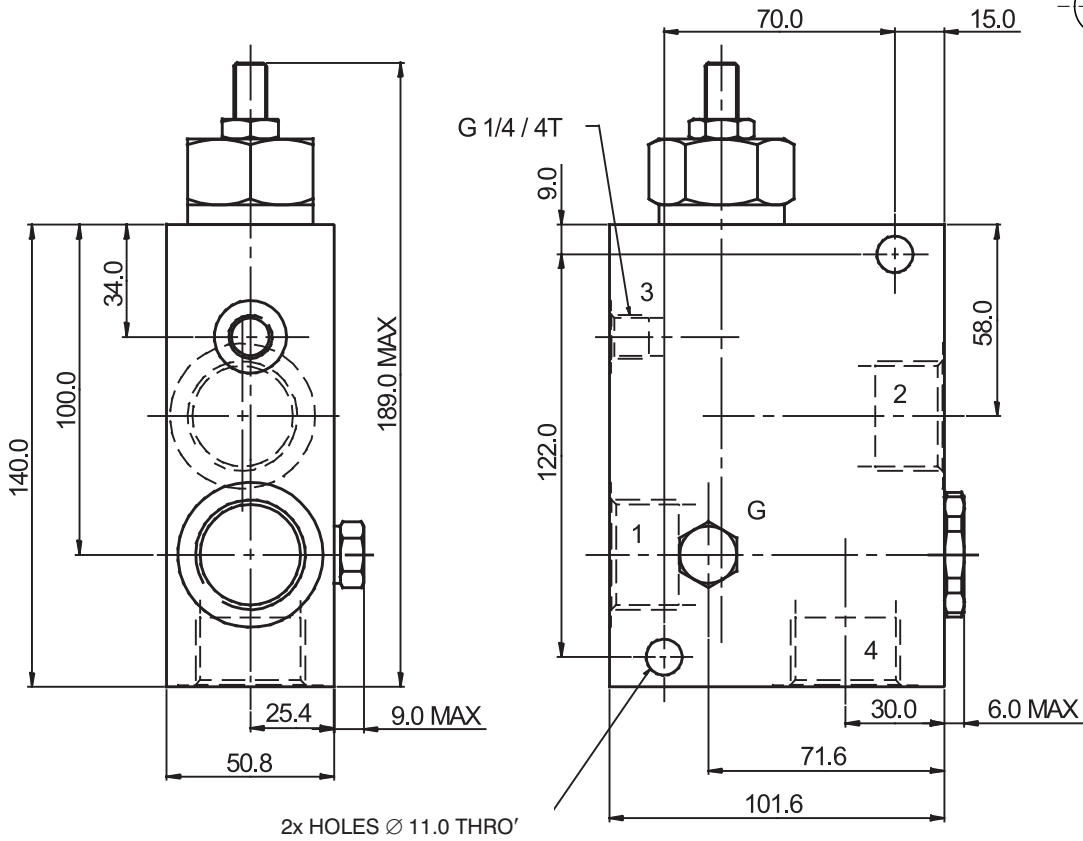
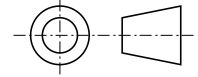

Body without valve			
Material	Ports	Port size	Type code
Aluminium	1, 2, 4	G1	SB-V4-0109AL
	3	G1/4	
	1, 2, 4	SAE 16, 1-5/16-12	SB-V4-0110AL
	3	SAE 6, 9/16-18	
Steel	1, 2, 4	G1/2	SB-V4-0109ST
	3	G1/4	
	1, 2, 4	SAE 16, 1-5/16-12	SB-V4-0110ST
	3	SAE 6, 9/16-18	

The use of aluminium bodies is limited to a maximum operating pressure of 210 bar.

Spare Parts

Seal kits on request.

Caution!

- The packing foil is recyclable.
- The technical information regarding the product presented in this catalogue is for descriptive purposes only. It should not be construed in any case as a guaranteed representation of the product properties in the sense of the law.

ARGO-HYTOS s.r.o. CZ - 543 15 Vrchlabí
 Tel.: +420-499-403111, Fax: +420-499-403421
 E-mail: sales.cz@argo-hytos.com
 www.argo-hytos.com

- May be used as accumulator charging valve
- For unloading a high flow – low pressure pump to tank
- May be used as priority circuit for steering and braking circuits
- Unloads to secondary system

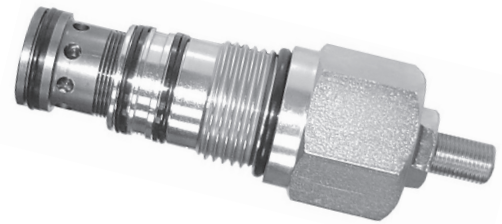
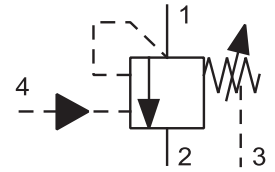

Functional Description

The valve consists of a ball control stage with a common drain into the storage tank, a main stage with a gate valve and a switching stage consisting of a bushing and a control gate valve. It is built-in in a secondary line in view of the feeding line. At the same time connections (1) and (4) are connected to the feeding line however they are separated mutually with the use of a one-way valve. For channel (1) on the side of the pump and channel (4) on the side of the system see page No 4.

The pressure in channel (1) acts through the nozzle hole in the longitudinal axis of the main gate valve also on its side loaded by the spring and through another nozzle hole in the switching stage to the control valve ball. As soon as this pressure exceeds a preset value of the spring force the ball is lifted from its seat and the control oil flows out to the storage tank. As a result of pressure difference the main gate valve is shifted against weak spring and the flow into the side channel (2) is released in this way.

The system pressure in channel (4) acting through the nozzle hole to the control gate valve prevents the control, stage from being shut off. The action of this pressure results in shifting the control gate valve in the direction against the ball of the control stage and in maintaining the ball in the lifted position from the seat. As soon as the system pressure drops to a value of 85% corresponding to the percentage to a ratio of areas of the control stage valve ball seat and the control gate valve the control stage and the main stage are shut off again and a new cycle can start.

As for appropriate basic surface finish the external parts are zinc coated.

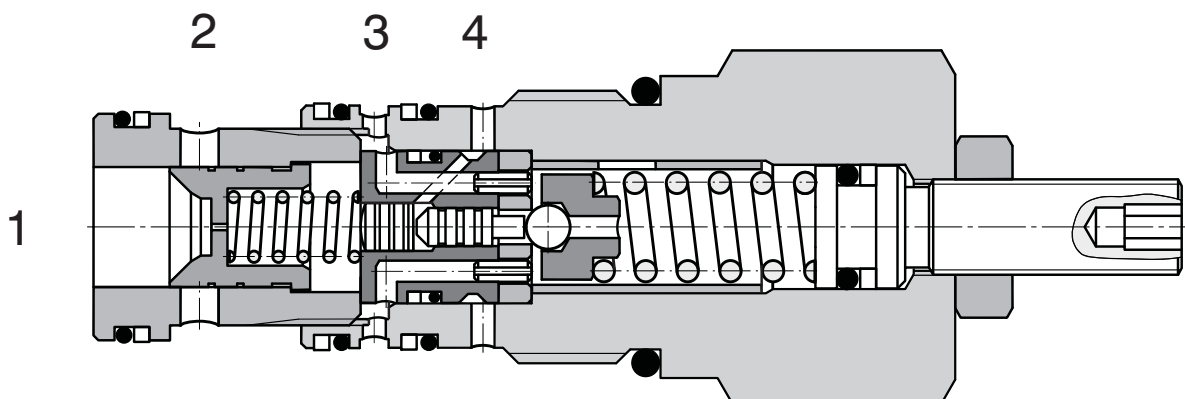

Ordering Code

SUD6A-U4/I

Pilot Operated Unloading Valve

no designation

Seals
NBR

Adjustable pressure

40 - 100 bar	10
70 - 200 bar	20
150 - 350 bar	35

Technical Data

Cavity		1-1/8-12 UNF-2A
Maximum flow	L/min	60
Max. pressure	bar	350
Differential unload/reload	%	10 - 15
Hydraulic fluid		Hydraulic oil (HM, HV) according to DIN 51524
Fluid temperature range	°C	-20 ... +90
Viscosity	mm ² /s	20 ... 400
Maximum degree of fluid contamination		According to ISO 4406, Class 21/18/15
Weight	kg	0.46
Maximum valve tightening torque in valve body or in control block	Nm	75 ⁺²
Mounting position		unrestricted

p-Q Characteristics

Measured at $v = 40 \text{ mm}^2/\text{s}$

Typical valve performance

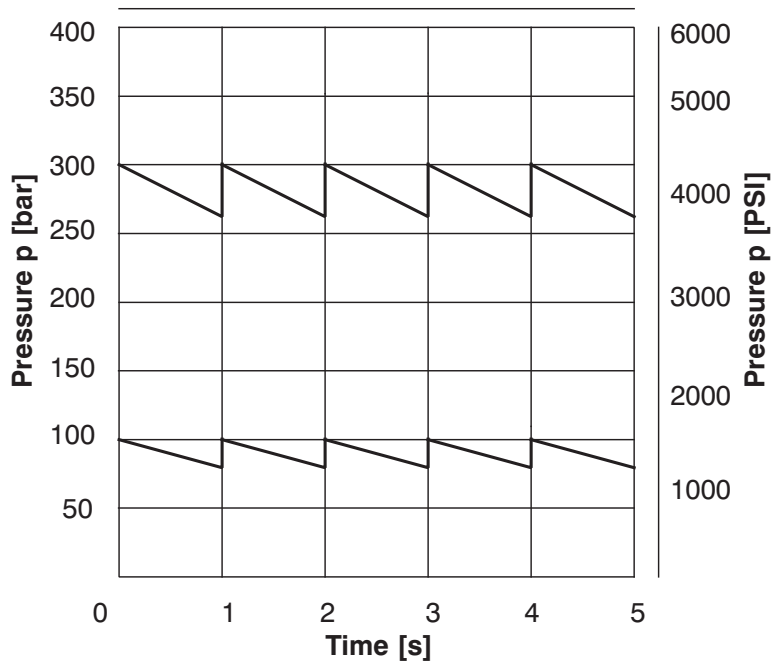

Dimensions

Measurements in millimeters

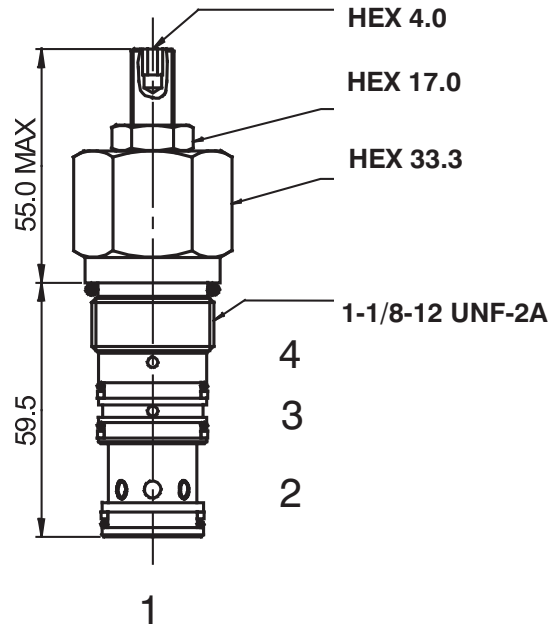

Cavity

Measurements in millimeters

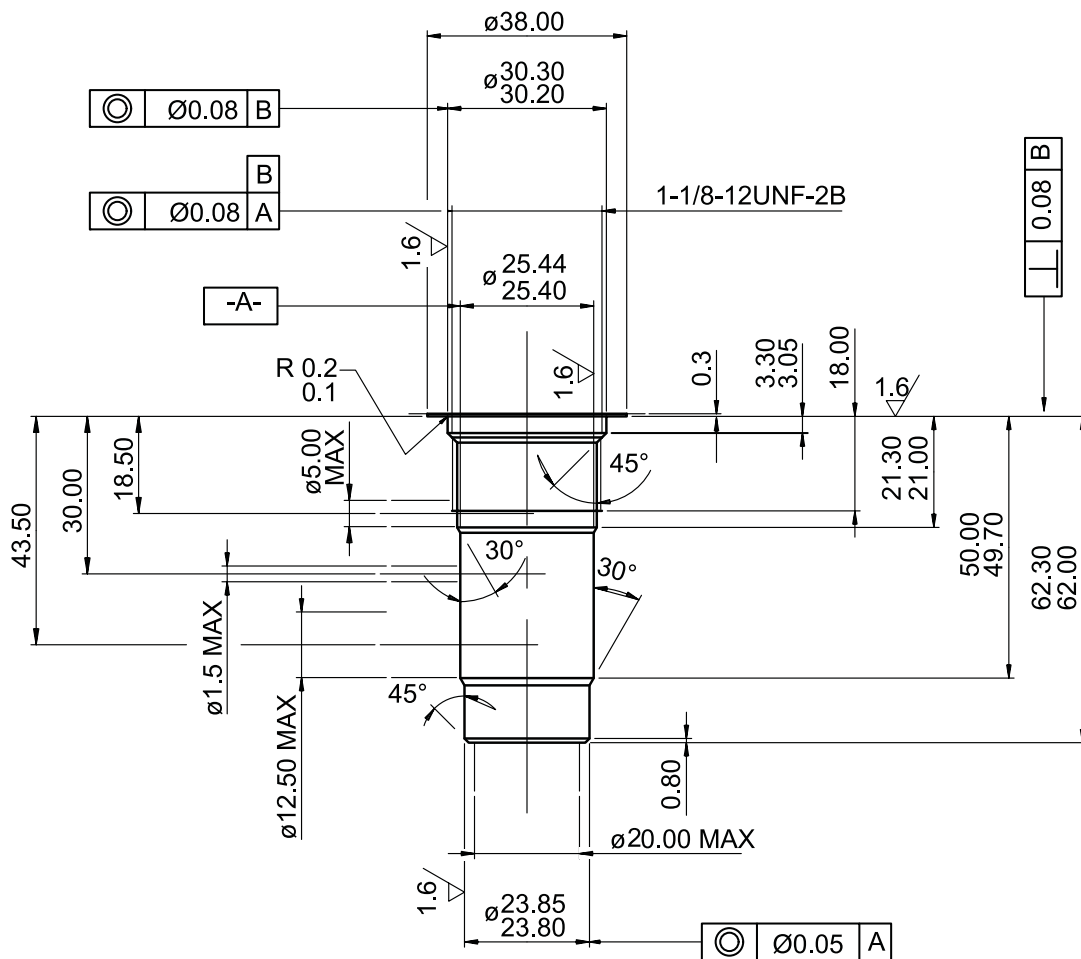

Valve Bodies

Measurements in millimeters

ISO A

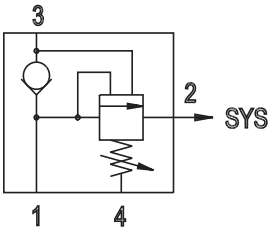
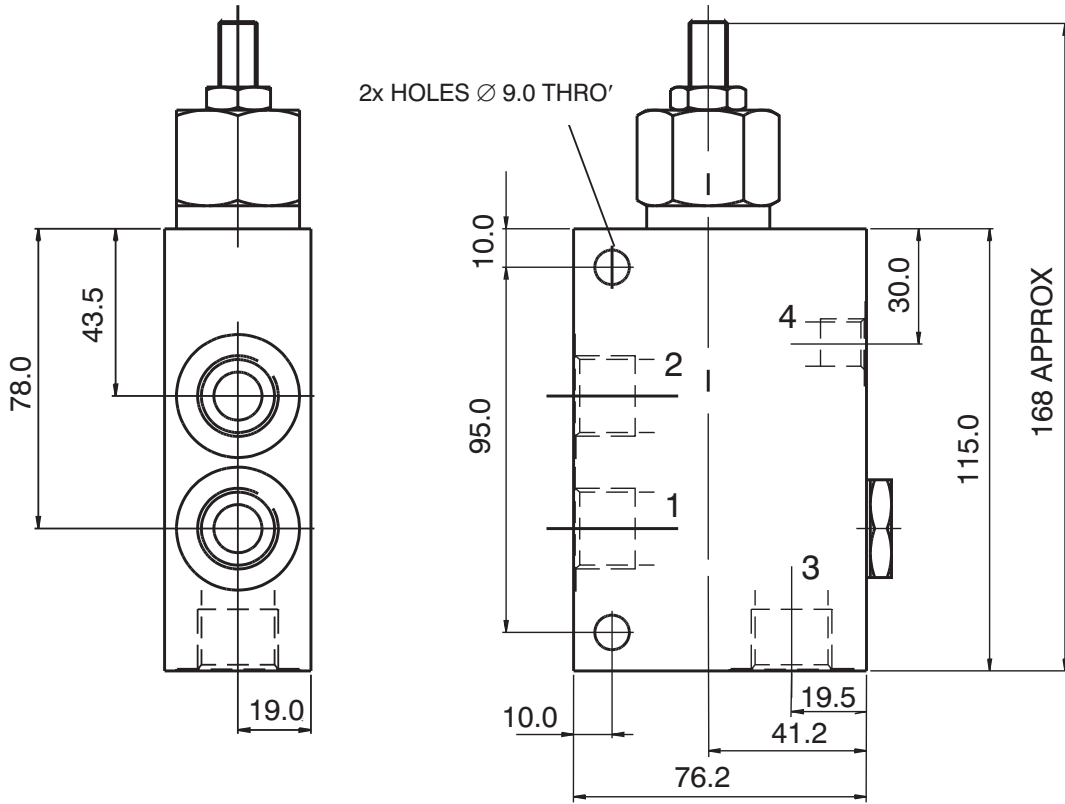
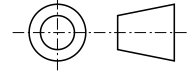

Body without valve			
Material	Ports	Port size	Type code
Aluminium	1, 2, 3	G1/2	SB-U4-0105AL
	4	G1/4	
	1, 2, 3	SAE 10, 7/8-14	SB-U4-0106AL
	4	SAE 6, 3/4-16	
Steel	1, 2, 3	G1/2	SB-U4-0105ST
	4	G1/4	
	1, 2, 3	SAE 10, 7/8-14	SB-U4-0106ST
	4	SAE 6, 3/4-16	

The use of aluminium bodies is limited to a maximum operating pressure of 210 bar.

Spare Parts

Seal kits on request.

Caution!

- The packing foil is recyclable.
- The technical information regarding the product presented in this catalogue is for descriptive purposes only. It should not be construed in any case as a guaranteed representation of the product properties in the sense of the law.

ARGO-HYTOS s.r.o. CZ - 543 15 Vrchlaví
 Tel.: +420-499-403111, Fax: +420-499-403421
 E-mail: sales.cz@argo-hytos.com
 www.argo-hytos.com







Flow Valves

4

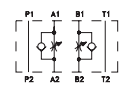
Flow Valves

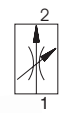
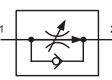
4

Symbol example	Flow l/min (GPM)	Pressure bar (PSI)	Type Code	Cartridge	NFPA D02, CETOP 2; NG4	NFPA D03, CETOP 3; NG6	NFPA D05, CETOP 5, NG10	Line Mounted	Page	Data Sheet
Fine Throttle valves										
	20 (5)	320 (4600)	VSV2	X					4.01	HA 5132
	20 (5)	100	VSO1-04/R					X	4.02	HA 5054
Double Throttle Check Valves										
	25 (7)	320 (4600)	VSO1-04/M		X				4.03	HA 5053
	80 (21)	320 (4600)	2VSO3-06			X			4.04	HA 5051
	100 (26)	350 (5100)	VSO2-10/M				X		4.05	HA 5056
Flow Control Valves										
	10 (3)	320 (4600)	VSK					X	4.06	HA 5121
2 Way Flow Control Valves										
	16 (4)	350 (5100)	SF22A-A2/H	X	(X)			(X)	4.10	HA 5060
	40 (11)	350 (5100)	SF22A-B2/H	X		(X)		(X)	4.11	HA 5067
2 Way Flow Control Valve with Free Flow Check Valves										
	22 (6)	320 (4600)	VSS1-206			X			4.07	HA 5032
	32 (8)	320 (4600)	VSS2-206						4.08	HA 5041
	60 (16)	350 (5100)	SF2C2A-K2/I	X				(X)	4.12	HA 5236
3 Way Flow Control Valves										
	16 (4)	320 (4600)	VSS1-306		X				4.09	HA 5033
	30 (8)	350 (5100)	SF32A-B3	X				(X)	4.16	HA 5070
	60 (16)	350 (5100)	SF32A-K3/I	X				(X)	4.13	HA 5227
Flow Divider / Combiner Valves										
	40 (11)	350 (5100)	SFD2F-B3/I	X				(X)	4.14	HA 5234
	150 (40)	350 (5100)	SFD2F-D3/I	X				(X)	4.15	HA 5235

Screw-in cartridge design

Use :
- Metering in one direction
- Metering in both directions

Flow rate set by adjustment screw internal to hexagon lock-nut



Functional Description

VSV2-1

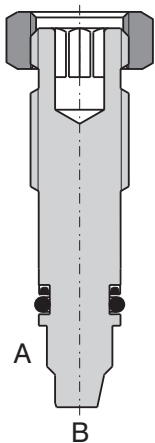

VSV2-J1

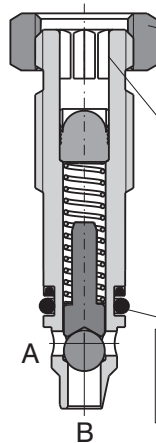

VSV2-J2

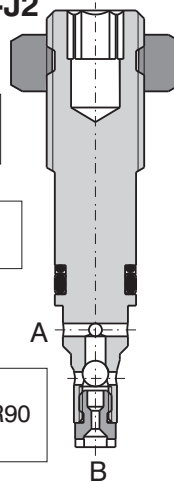

Lock-nut
outside HEX 19

Screw
inside HEX 6

Seals
6,73x9,43x1,14 NBR90
6,9x1,8 NBR70

Throttle valve VSV2 is used to control the flow in a hydraulic system in one or both directions.

- 1) A higher sensitivity control is achieved by using the M12x1 screw thread
- 2) After loosening the lock nut the valve may be screwed out only up to the red marked safety notch; otherwise the valve could get completely unscrewed leading to working fluid escape.

Ordering Code

Screw-in Cartridge Throttle Valve

1 without check valve
J1 with check valve, non regulated flow B→A
J2 with check valve, non regulated flow A→B

Model

M12x1

Thread
M12x1

VSV2 - /

Functional Symbols

VSV2-1 without check valve



VSV2-J1 with check valve, non regulated flow B→A

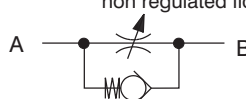

VSV2-J2 with check valve, non regulated flow A→B

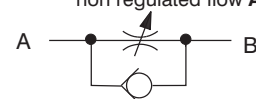

Technical Data

Nominal size	mm	M12x1
Max. operating pressure	bar (PSI)	320 (4641)
Hydraulic fluid		Hydraulic oils of power classes (HL, HLP) to DIN 51 524
Fluid temperature range	°C (°F)	-30 ... +100 (-22 ... +212)
Viscosity range	mm ² /s (SUS)	20 ... 400 (98 ... 1840)
Maximum degree of fluid contamination		Class 21/18/15 to ISO 4406
Weight	kg (lbs)	0,11 (0.243)
Mounting position		unrestricted

Δp Characteristics

Measured at $v = 32 \text{ mm}^2/\text{s}$ (156 SUS)

VSV2-J1 - Flow direction B → A ———
 VSV2-J2 - Flow direction A → B - - - - -
 1 - Throttle valve closed
 2 - Throttle valve open

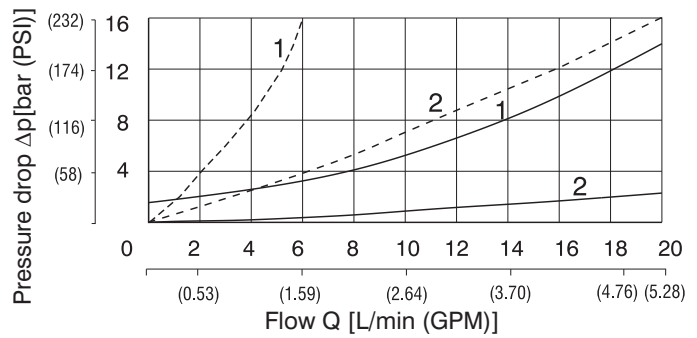

p-Q Characteristics

Measured at $v = 32 \text{ mm}^2/\text{s}$ (156 SUS)

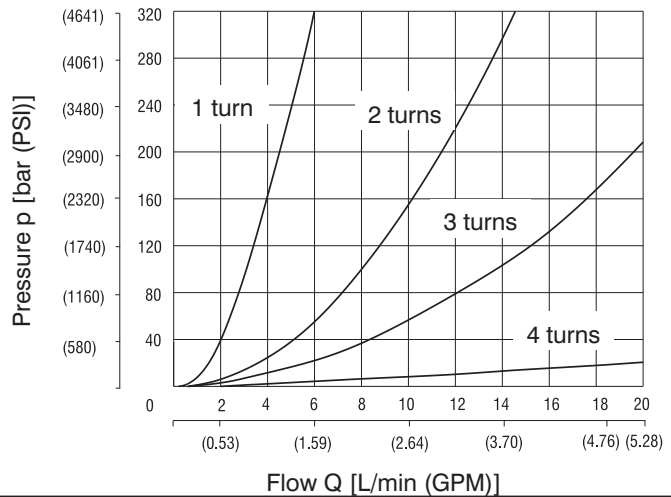

4

Cavity

Dimensions in millimeters (inches)

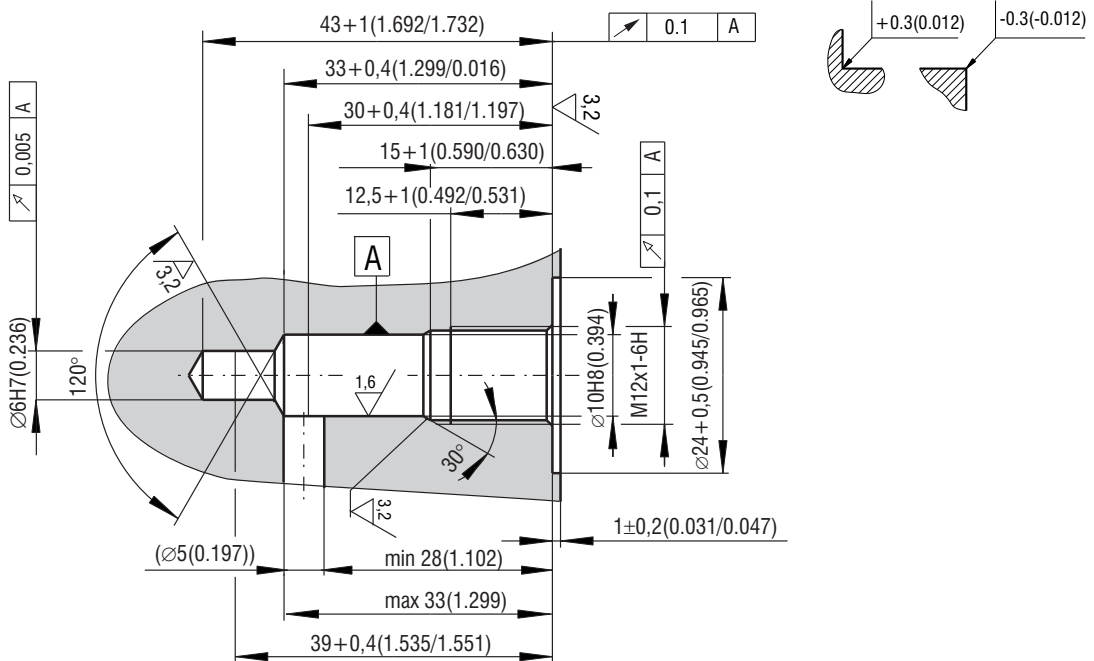

Caution!

- The packing foil is recyclable.
- The technical information regarding the product presented in this catalogue is for descriptive purposes only. It should not be construed in any way as a guaranteed representation of the product properties in any legal sense.

ARGO-HYTOS s.r.o. CZ - 543 15 Vrchlabí
 Tel.: +420-499-403111, Fax: +420-499-403421
 E-mail: sales.cz@argo-hytos.com
 www.argo-hytos.com

- In-line mounting
- Attachment under panel
- Three models:
 - Fine throttle valve
 - Fine throttle valve + check valve in parallel
 - Fine throttle valve + check valve in series
- Four throttle seat diameters

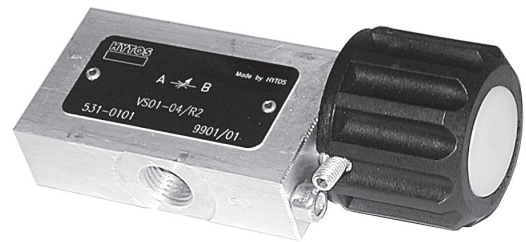

Functional Description

Fine throttle valves are used to control flow rates of pressure fluid. The connection threads in the valve body enable direct installation in line or hose. The valve is designed to be attached on the backside of a control panel by means of two bolts M6 (1). The outer bolt with the cylindrical head serves at the same time to limit to one revolution the hand knob.

The adjustment sensitivity of flow rate can be selected by using the respective seat diameter in the range from 2 up to 3.5 mm (see the flow characteristics).

The attachment under the panel is carried out after removing the hand knob (2). The position of the hand

knob can then be adjusted either to the stop of the mounting bolt, or in line with the requested flow limitation, in a smaller angle of rotation.

If needed, the simple fine throttle valve can be completed with a check valve of the type VJO1-06/SG (3) HA 5004 which is installed in series.

To ensure the reverse free-flow through the valve, the model VSO1-04/Rx-O with a parallel ball valve (4) can be used.

The valve body is made of aluminum, the other parts of the valve do not have any surface treatment.

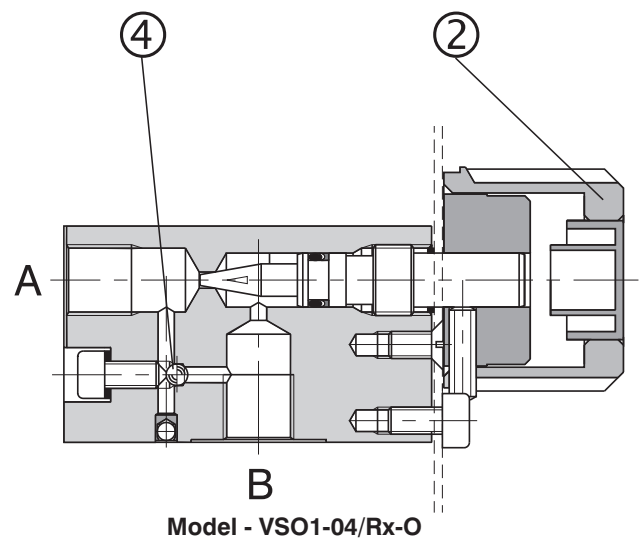
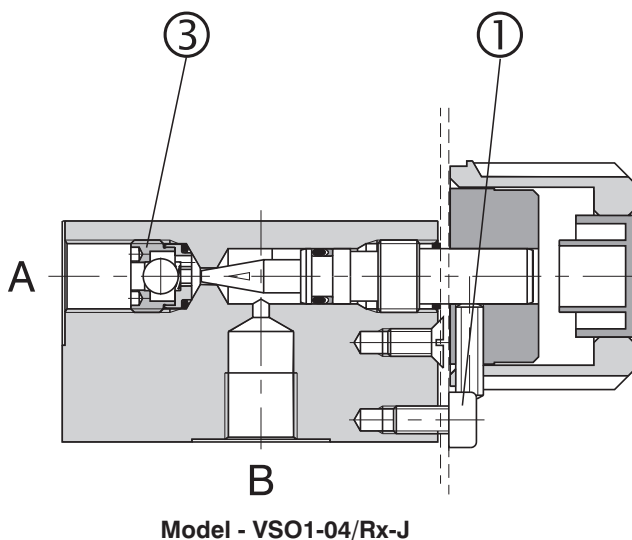

Ordering Code

VSO1-04/R -

Fine Throttle Valve

Nominal size

04 (D 02)

In-line mounting

without designation

Model

without check valve*

with check valve in series*

with check valve in parallel*

* see Functional Symbols

J
O

Seat diameter

mm (0.787 in)

mm (0.984 in)

mm (0.118 in)

mm (0.138 in)

Other seat diameters after consultation.

2
2,5
3
3,5

4

Functional Symbols

VSO1-04/Rx

without check valve



VSO1-04/Rx-J

with check valve in series

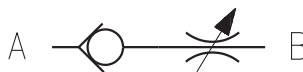

VSO1-04/Rx-O

with check valve in parallel

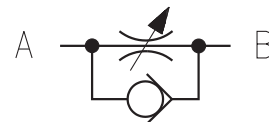

Technical Data

Nominal size	mm (US)	04 (D 02)
Max. operating pressure	bar (PSI)	100 (1450)
Hydraulic fluid		Hydraulic oils of power classes (HL, HLP) to DIN 51524
Fluid temperature range for (NBR)	°C (°F)	-30 ... +100 (-22... +212)
Viscosity range	mm ² /s (SUS)	20 ... 400 (98... 1840)
Maximum degree of fluid contamination		Class 21/18/15 to ISO 4406
Weight	kg (lbs)	0,22 (0.485)
Mounting position		unrestricted

p-Q Characteristics

Measured at $v = 32 \text{ mm}^2/\text{s}$ (156 SUS)

The characteristics were measured at hand knob positions set by 30°.

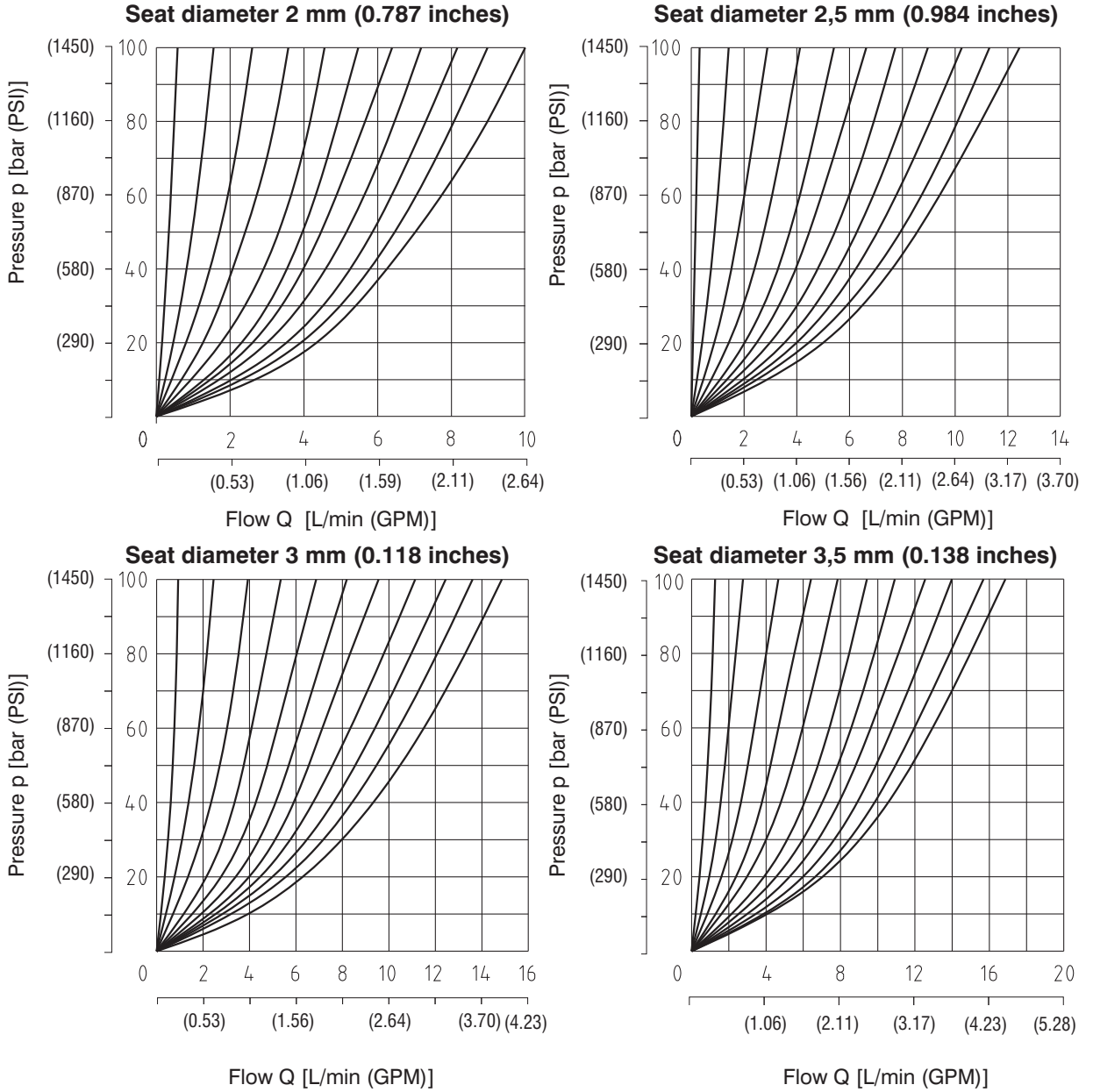

4

Δp-Q Characteristics

Measured at $v = 32 \text{ mm}^2/\text{s}$ (156 SUS)

Valid for model VSO1-04/R20,
flow direction B-A

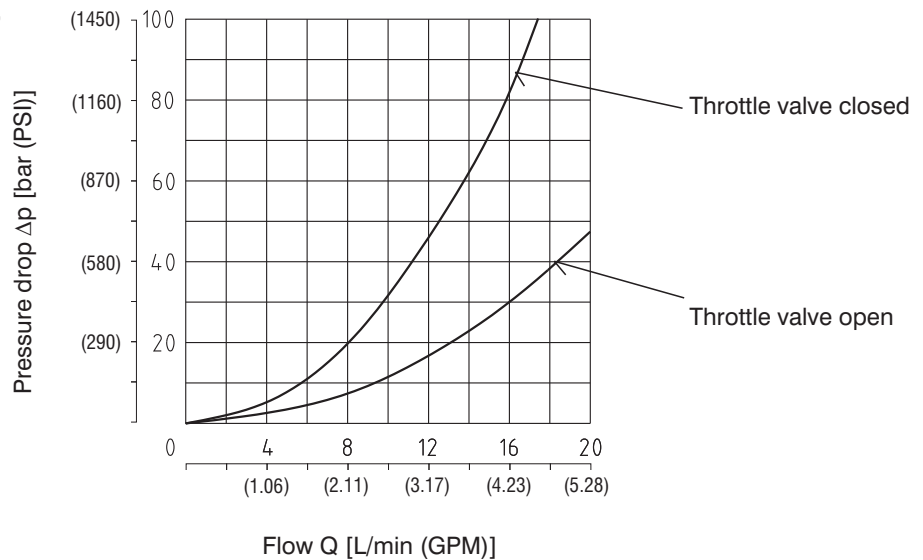

Valve Dimensions

Dimensions in millimeters (inches)

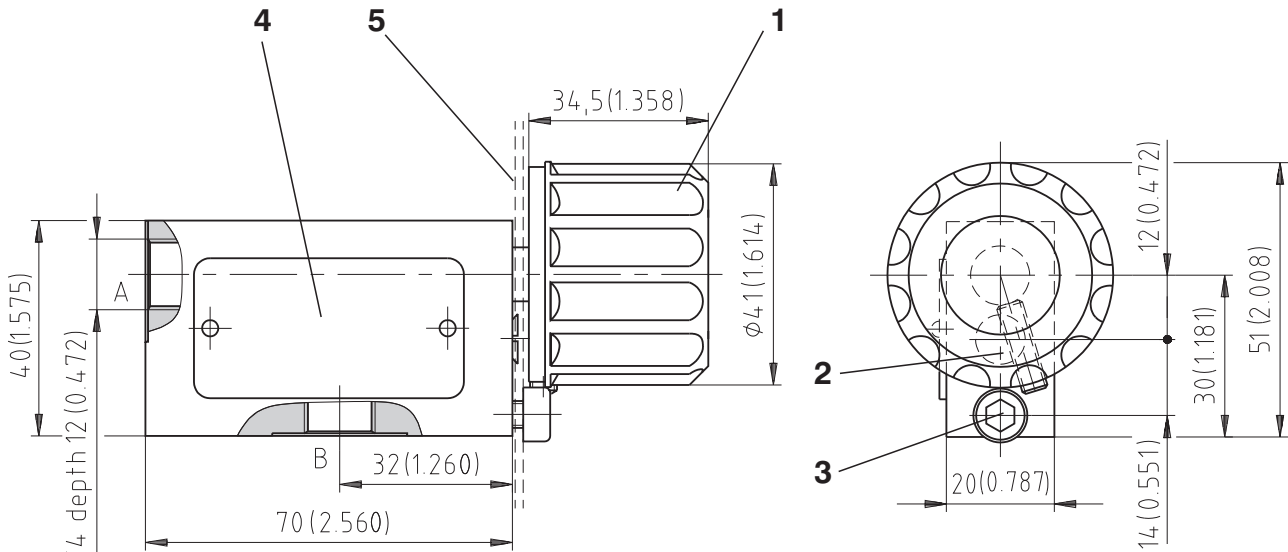

- 1 Hand knob
- 2 Bolt for valve attachment under plate of control panel
- 3 Bolt for valve attachment, limits the hand knob rotation
- 4 Name plate
- 5 Control panel plate

Board

Dimensions in millimeters (inches)

Installation Dimensions

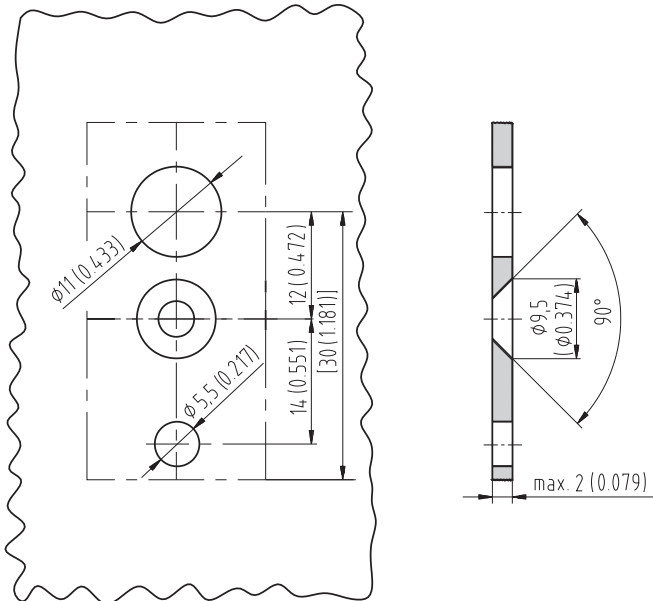

Caution!

- The packing foil is recyclable.
- The technical information regarding the product presented in this catalogue is for descriptive purposes only. It should not be construed in any case as a guaranteed representation of the product properties in the sense of the law.

ARGO-HYTOS s.r.o. CZ - 543 15 Vrchlaví
 Tel.: +420-499-403111, Fax: +420-499-403421
 E-mail: sales.cz@argo-hytos.com
 www.argo-hytos.com

- Sandwich plate design for use in vertical stacking assemblies
- Meter-in or meter-out control as required
- Three possible arrangements:
 - throttle valve in channel A
 - throttle valve in channel B
 - throttle valves in channels A and B
- Flow adjustment - hexagon set screw with locknut and protective cap
- Installation dimensions to ISO 4401:1994 and DIN 24 340-A6

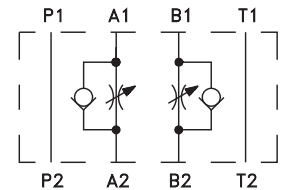

Functional Description

Double throttle valves are used to control flow rates in two separate lines (A,B) of a hydraulic circuit. The modular design provides six functional symbols.

The valve body (1) has drilled channels and the throttle valve is built into channel A or B or into channels A and B. They restrict the fluid flow in one direction while providing reverse free-flow in the opposite direction. The throttling spool (2) is adjusted by means of a set screw (3) and each spool position corresponds with a certain area of passage.

Fluid entering port A1 is throttled to port A2 via a groove and an annulus area. Fluid returning from port B2 shifts

the valve seat (4) against the spring (5), thus creating a passage which allows reverse free-flow to port B1 (function of a check valve).

The sandwich design enables simple stacking with other components of the same size.

According to the valve arrangement, the meter-in or meter-out control is provided. The orientation of the throttle check valves in the valve body corresponds with the symbols shown on the name plate.

The valve housing (1) is phosphate coated, the surfaces of the other parts are zinc coated.

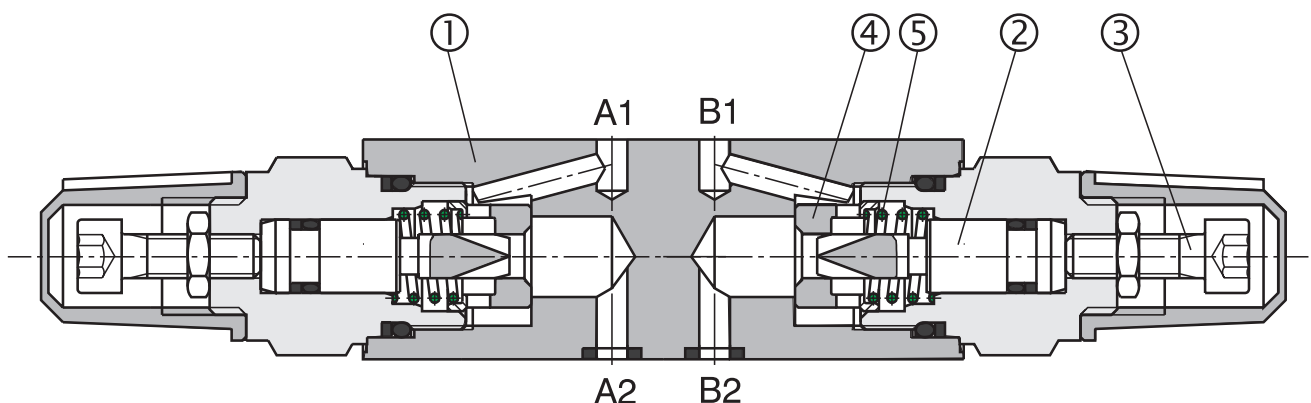

Ordering Code

VSO1-04/M S

Double Throttle Check Valve

Nominal size

Modular design

no designation
V

Seals
NBR
FPM (Viton)

Adjustment element
Hexagon set screw with locknut
and protective cap

A
B
C
E
F
D

Functional Symbols
check valve in line A*
check valve in line B*
check valves in lines A and B*
check valve in line A*
check valve in line B*
check valves in lines A and B*
* see Functional Symbols

4

Functional Symbols

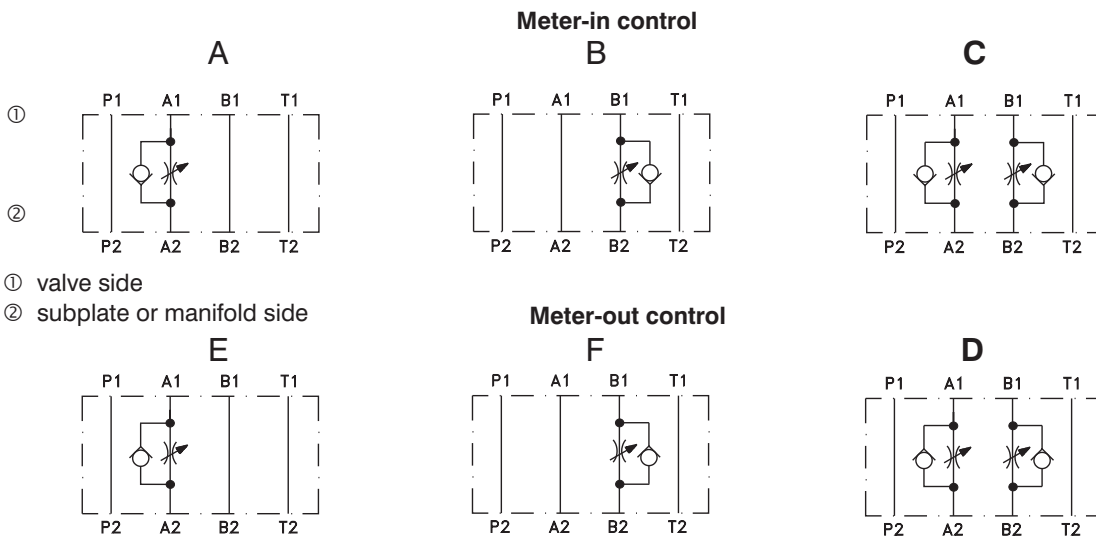

Notes: The orientation of the throttle check valves in the valve body corresponds with symbols shown on the name plate.

Technical Data

Nominal size	mm	04
Maximum flow	L/min	25
Maximum operating pressure	bar	320
Hydraulic fluid	Hydraulic oils of power classes (HL, HLP) to DIN 51524	
Fluid temperature range for (NBR)	°C	-30 ... +100
Fluid temperature range for (Viton)	°C	-20 ... +120
Viscosity range	mm ² /s	20 ... 400
Maximum degree of fluid contamination	Class 21/18/15 to ISO 4406	
Weight	kg	0.8
Mounting position	unrestricted	

Δp-Q Characteristics

Measured at $v = 32 \text{ mm}^2/\text{s}$

Throttle valve

Pressure difference Δp related to flow from A1 to A2, (from B1 to B2)

- Throttle setting in turns (from the end stop)

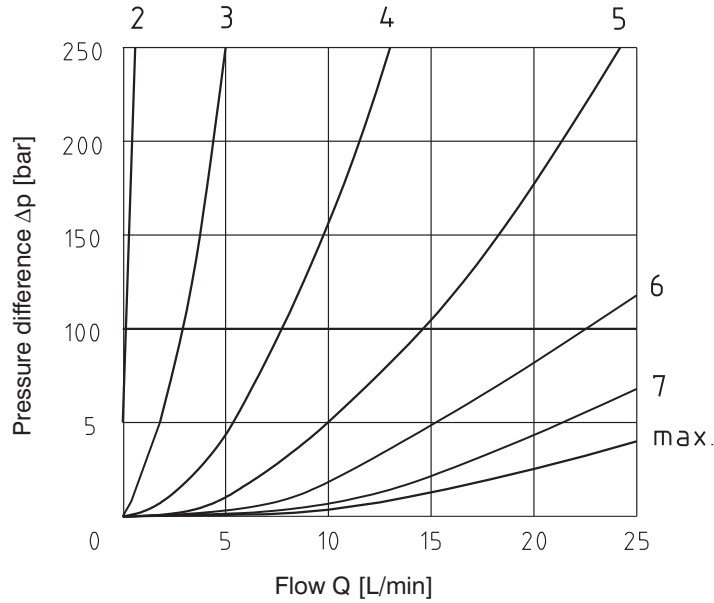

Check valve

pressure difference Δp related to flow from A2 to A1 (from B2 to B1)

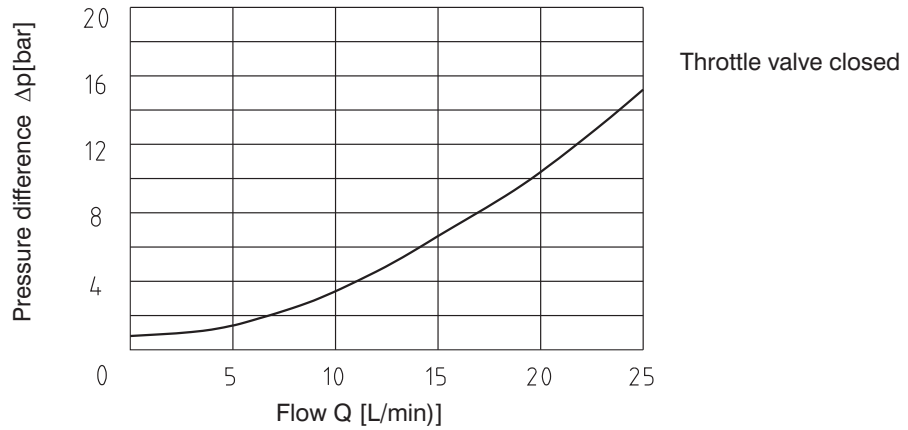

Spare Parts

Seal kit

Type	Dimensions, quantity		Ordering number
	O-ring	Square ring	
Standard NBR70	-	7,65 x 1,68 (4 pcs.)	20718400
Viton	7,65 x 1,68 (4pcs.)	-	28618000

Valve Dimensions

Dimensions in millimeters

Typ VSO1-04/MAS
Typ VSO1-04/MES

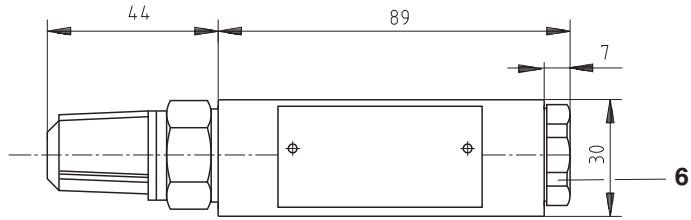

Typ VSO1-04/MBS
Typ VSO1-04/MFS

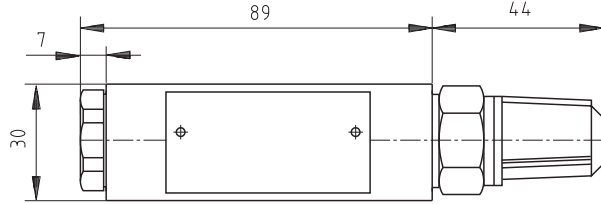

Typ VSO1-04/MCS
Typ VSO1-04/MDS

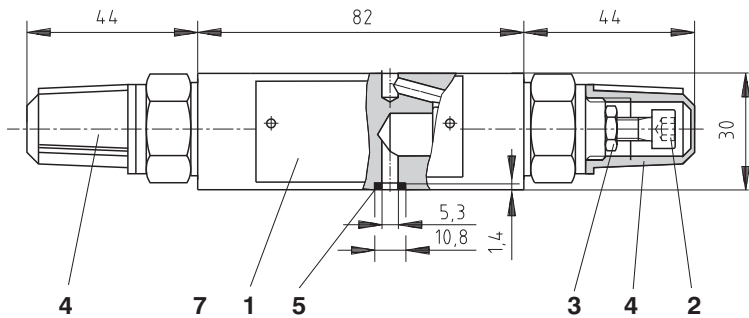

0,01/100 mm
0,8 (Rmax. 6,3)

Required surface finish of interface

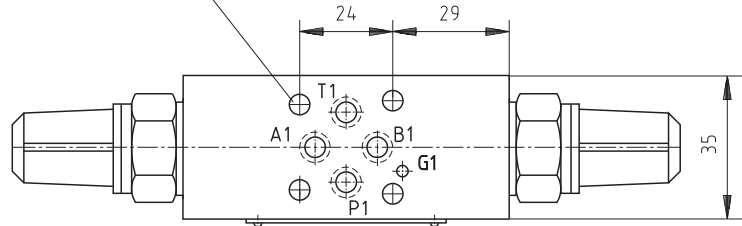

Installation Dimensions

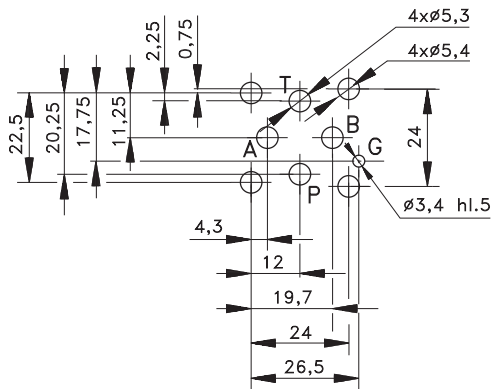

- 1 Name plate
- 2 Set screw - Inside HEX 5
Clockwise rotation = flow decrease
Counterclockwise rotation = flow increase
- 3 Locknut, HEX 10
- 4 Protective cap
- 5 Square ring (4 pcs.) supplied with valve
- 6 Closing screw
- 7 4 mounting holes

Caution!

- The packing foil is recyclable. The protective plate can be returned to manufacturer.
- A cover plate DK 1-04/32-x with the respective channel connection can be ordered separately - see catalogue HA 0003 - Cover plates.
- Mounting bolts M6x40 DIN 912-10.9 or studs must be ordered separately. Tightening torque 5 Nm.
- For applications outside these parameters, please consult the manufacturer.
- The technical information regarding the product presented in this catalogue is for descriptive purposes only. It should not be construed in any case as a guaranteed representation of the product properties in the sense of the law.

ARGO-HYTOS s.r.o. CZ - 543 15 Vrchlabí
Tel.: +420-499-403111, Fax: +420-499-403421
E-mail: sales.cz@argo-hytos.com
www.argo-hytos.com

- Sandwich plate design for use in vertical stacking assemblies
- Meter-in or meter-out control as required
- Three possible arrangements:
 - throttle valve in channel A
 - throttle valve in channel B
 - throttle valves in channels A and B
- Flow adjustment - three adjustment elements
- Installation dimensions to ISO 4401:1994 and DIN 24 340-A6
- Subplates - see Catalogue HA 0002

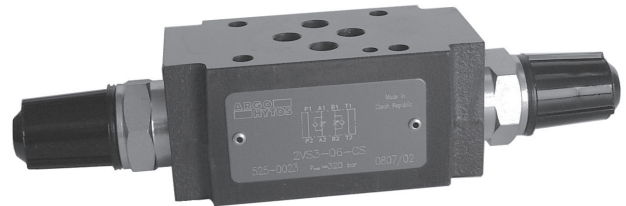
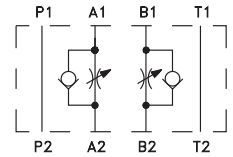

4

Functional Description

Double throttle valves are used to control flow rates in two separate lines (A, B) of a hydraulic circuit. The modular design provides six functional symbols. The throttle valve is built into channel A or B or into channels A and B. The valve restricts the fluid flow in one direction while providing reverse free-flow in the opposite direction. The throttling spool (2) is adjusted by means of a set screw (3) and each spool position corresponds with a certain passage area. Fluid entering port A1 is throttled to port A2 via a groove and an annulus area. Fluid returning from port B2 shifts the valve seat (4) against the spring (5), thus creating a passage which allows reverse free-flow to port B1 (function as a check valve).

The sandwich design enables simple stacking with other components of the same size. The separate O-ring plate (6) with fitted O rings provides sealing of the valve connecting surface. According to the valve arrangement, the meter-in or meter-out control is provided. Changing the meter-in mode into the meter-out mode can be done by turning the valve by 180° around its horizontal axis. The orientation of the throttle check valves in the valve body corresponds with the symbols shown on the name plate. The set screw can be operated by a key, by a hand knob or by a hand knob with keylock. The basic surface treatment of the valve housing is phosphate coated, whereas the surfaces of the other parts are zinc coated.

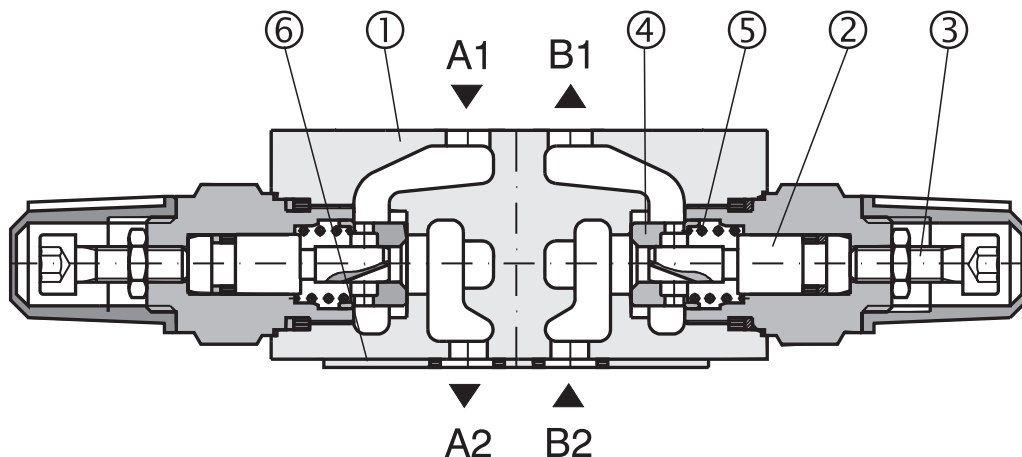

Ordering Code

2VS3 - 06 -

Double Throttle Check Valve

Nominal size

no designation
V

Seals
NBR
Viton

Adjustment element
S Hexagon set screw with locknut and protective cap
R Hand knob with scale
Z Hand knob with scale and keylock

Functional Symbols
A check valve in line A*
B check valve in line B*
C check valves in lines A and B*
* see Functional Symbols

FOR PREFERRED TYPES SEE BOLD TYPING IN ORDERING CODE AND TABLE OF PREFERRED TYPES ON PAGE 3

Functional Symbols

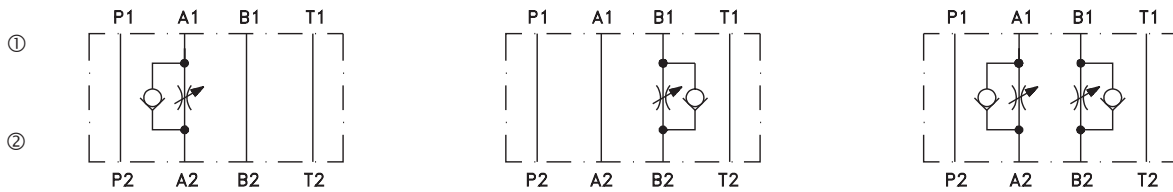

Notes: ① valve side
② subplate or manifold side
The orientation of the throttle check valves in the valve body corresponds with symbols shown on the name plate.

Technical Data

Nominal size	mm	06
Maximum flow rate	L/min	80
Maximum operating pressure	bar	320
Hydraulic fluid		Hydraulic oils of power classes (HL, HLP) to DIN 51524
Fluid temperature range for (NBR)	°C	-30 ... +100
Fluid temperature range for (Viton)	°C	-20 ... +120
Viscosity range	mm ² /s	20 ... 400
Maximum degree of fluid contamination		Class 21/18/15 according to ISO 4406
Weight	kg	1,2
Mounting position		unrestricted

Spare Parts

Seal kit

Type	Dimensions, quantity			Ordering number
	O-ring	Square ring	Back-up ring	
Standard NBR	18 x 2.65 NBR70 (2 pcs.)	9.25 x 1.68 (4 pcs.)	6.73 x 9.43 x 1.14 (2 pcs.)	15936300
	6.9 x 1.8 NBR70 (2 pcs.)	-	17.83 x 22.19 x 1.14 (2 pcs.)	
Viton	17.12 x 2.62 (2 pcs.)	-	9.43 x 6.73 x 1.14 (2 pcs.)	15936600
	9.25 x 1.78 (4 pcs.)	-	17.83 x 22.19 x 1.14 (2 pcs.)	
	6.75 x 1.78 (2 pcs.)	-	-	

Δp-Q Characteristics

Measured at $v = 32 \text{ mm}^2/\text{s}$

Throttle valve

Pressure difference Δp related to flow from A1 to A2, (from B1 to B2)

- Throttle setting in turns (from the end stop)

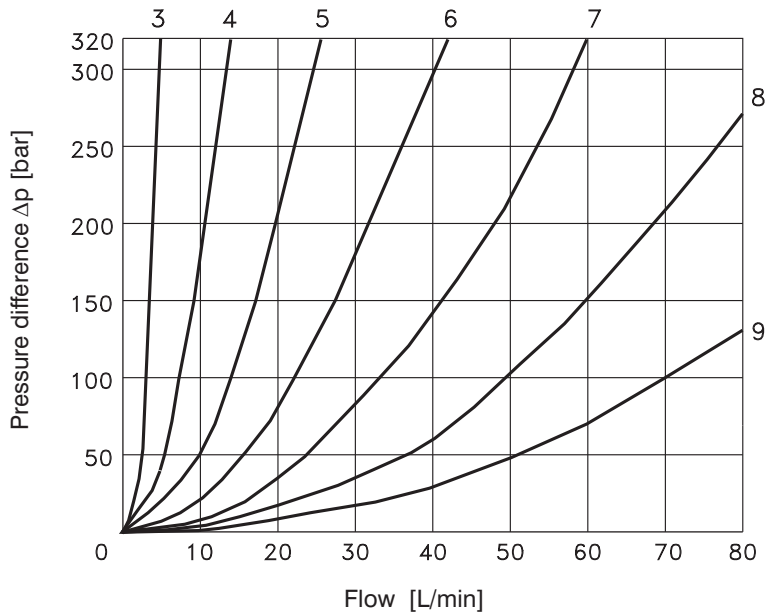

Check valve

Pressure difference Δp related to flow from A2 to A1, (from B2 to B1)

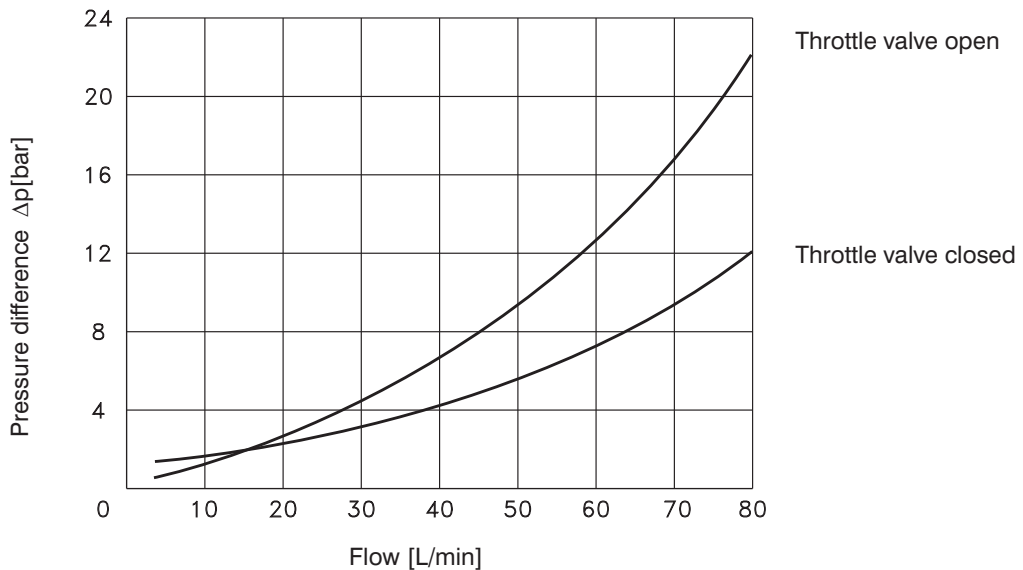

Preferred Types of Valves

Type	Ordering Number
2VS3-06-CS	15929600

Caution!

- The packing foil is recyclable. The protective plate can be returned to manufacturer.
- Mounting bolts must be ordered separately. Tightening torque is 8.9 Nm.
- If the valve is used separately without a directional valve, a cover plate DK1-06/32-1 is to be ordered. This plate connects port A1 with B1 and A2 with B2 respectively (suitable for models 2VS3-06-Ax and 2VS3-06-Bx) - see catalogue Cover Plates and Crossover Cover Plates HA 0003.
- The technical information regarding the product presented in this catalogue is for descriptive purposes only. It should not be construed in any case as a guaranteed representation of the product properties in the sense of the law.

Valve Dimensions

Dimensions in millimetres

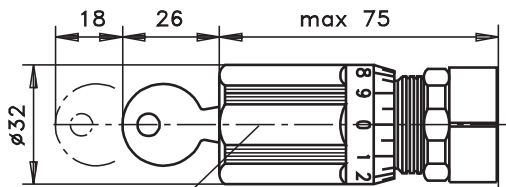

- 1 Name plate
 - 2 Adjustment element - Inside HEX 5 with lock nut and protective cup
 - 3 Adjustment element - hand knob with scale
 - 4 Adjustment element - hand knob with scale and keylock
- With all adjustment elements:
clockwise rotation reduces flow
counter - clockwise rotation increases flow
- 5 Locknut HEX10
 - 6 O-ring plate - supplied in delivery packet
 - 7 Square ring 9.25x1.68 (4 pcs.) - supplied in delivery packet
 - 8 Closing screw

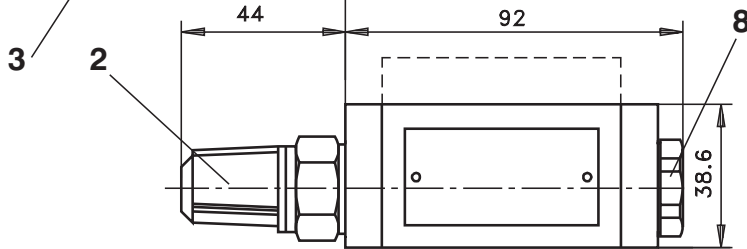
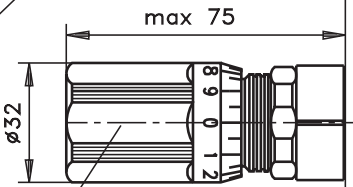

2VS3-06A

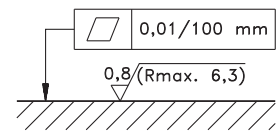

Required surface finish of interface

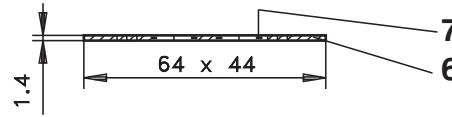

2VS3-06B

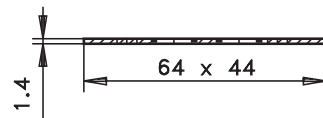
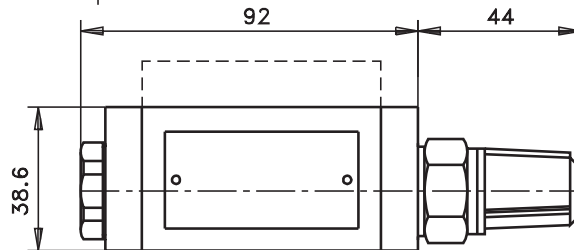

2VS3-06C

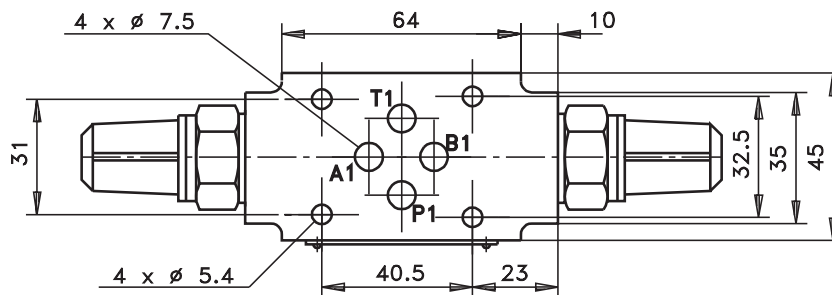
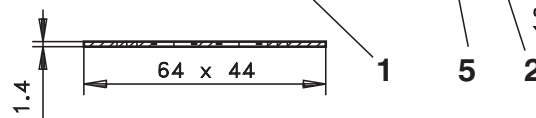
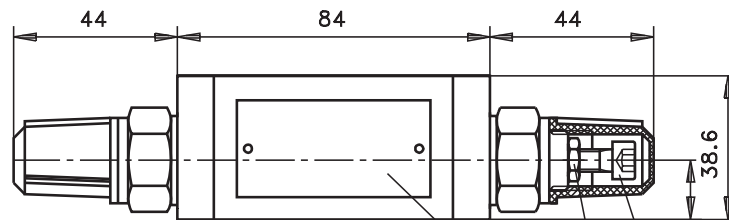

ARGO-HYTOS s.r.o. CZ - 543 15 Vrchlábí
 Tel.: +420-499-403111, Fax: +420-499-403421
 E-mail: sales.cz@argo-hytos.com
 www.argo-hytos.com

- Modular design for use in vertical stacking assemblies
- Meter-in or meter-out control
- Three functional symbols:
 - throttle valve in line A
 - throttle valve in line B
 - throttle valves in lines A and B
- Flow adjustment - hexagon set screw with locknut and protective cap
- Installation dimensions to ISO 4401-05-04-0-94 and DIN 24 340-A10

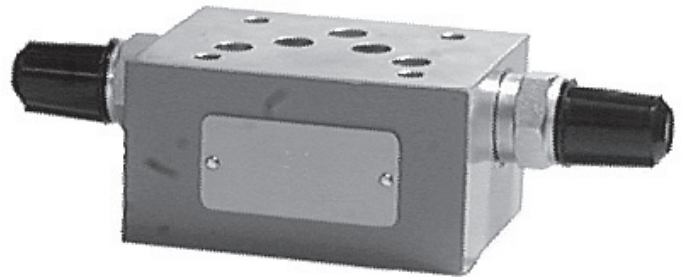
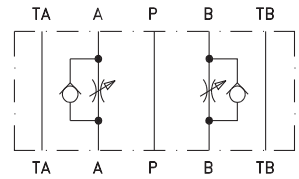

Functional Description

Double throttle valves are used to control flow rates in two separate lines (A, B) of a hydraulic circuit.

The valve body (1) has drilled channels and the throttle valve is built into channel A or B or into channels A and B. They restrict the fluid flow in one direction while providing reverse free-flow in the opposite direction. The throttling spool (2) is adjusted by means of set screw (3) and each spool position corresponds with a certain area of the flow passage.

Fluid entering port A1 is throttled to port A2 via a groove and an annulus area. Fluid entering port B2 shifts the valve seat (4) against the spring (5), thus creating a passage which allows reverse free-flow to port B1 (function of a check valve).

The modular design enables simple vertical stacking with other components of the same size. A separate O-ring plate (6) with fitted O-rings is mounted underneath the valve body, thus providing its sealing. According to the valve arrangement, the meter-in or meter-out control is provided. Changing the meter-in mode into the meter-out mode can be done by turning the valve body by 180° around its x-axis.

The orientation of the throttle/check valves in the valve body corresponds with the symbols shown on the name plate.

The basic surface treatment of the valve housing (1) is phosphate coated, whereas the surfaces of the other parts are zinc coated.

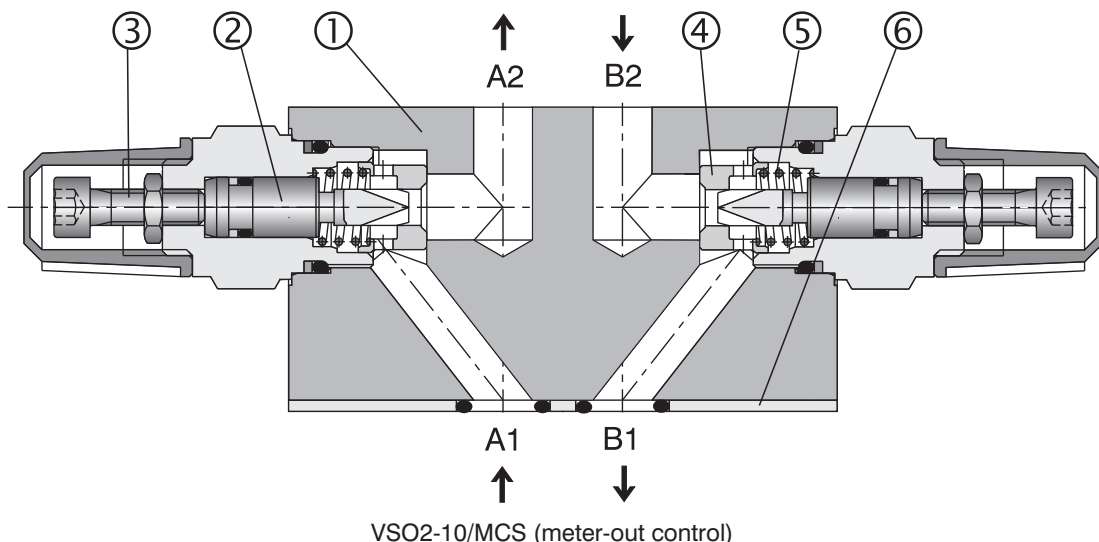

Ordering Code

VSO2-10/M

Double Throttle Check Valve

Nominal size

Modular design

Seals
 no designation V
 Standard (NBR)
 Viton (FPM)

Adjustment element
 S
 Set screw with inside hexagon

A
B
C

Functional Symbols
 check valve in line A*
 check valve in line B*
 check valves in lines A and B*
 * see Functional Symbols

4

Functional Symbols

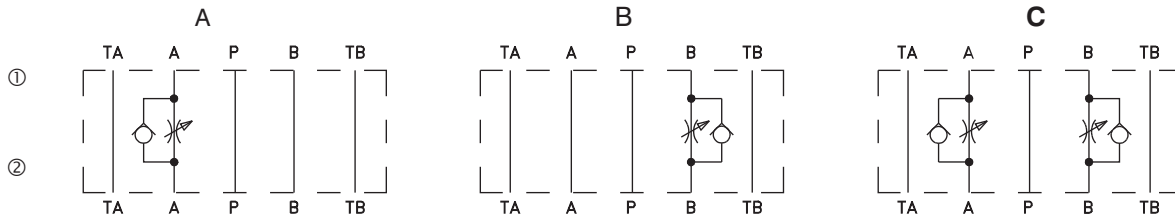

Notes: ① valve side
 ② subplate or manifold side
 The orientation of the symbol shown on the name plate corresponds with the function of the valve (meter-out control).

Technical Data

Nominal size	mm	10
Maximum flow rate	L/min	100
Maximum operating pressure	bar	350
Hydraulic fluid	Hydraulic oils of power classes (HL, HLP) to DIN 51524	
Fluid temperature range for (NBR)	°C	-30 ... +100
Fluid temperature range for (Viton)	°C	-20 ... +120
Viscosity range	mm ² /s	20 ... 400
Maximum degree of fluid contamination	Class 21/18/15 according to ISO 4406	
Weight	kg	2.15
Mounting position	unrestricted	

Caution!

- The packing foil is recyclable. The protective plate can be returned to manufacturer.
- Mounting bolts must be ordered separately. Tightening torque of the screws is 15 Nm.
- The technical information regarding the product presented in this catalogue is for descriptive purposes only. It should not be construed in any case as a guaranteed representation of the product properties in the sense of the law.

Δp-Q Characteristics

Measured at $v = 32 \text{ mm}^2/\text{s}$

Throttle valve

Pressure difference Δp related to flow from A1 to A2, (from B1 to B2)

- Throttle setting in turns (from the end stop)

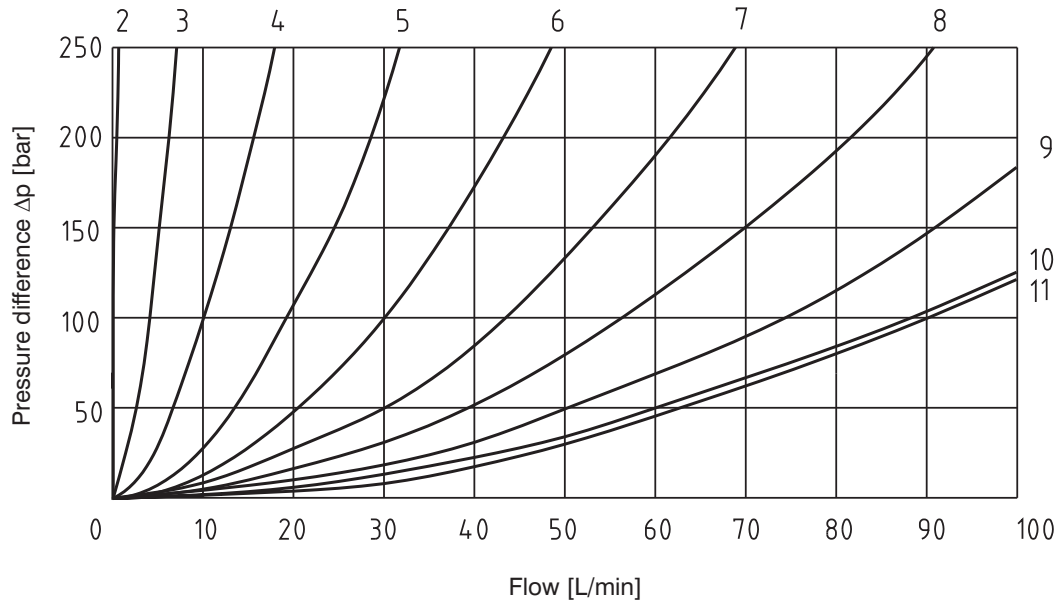

Check valve

Pressure difference Δp related to flow from A2 to A1, (from B2 to B1)

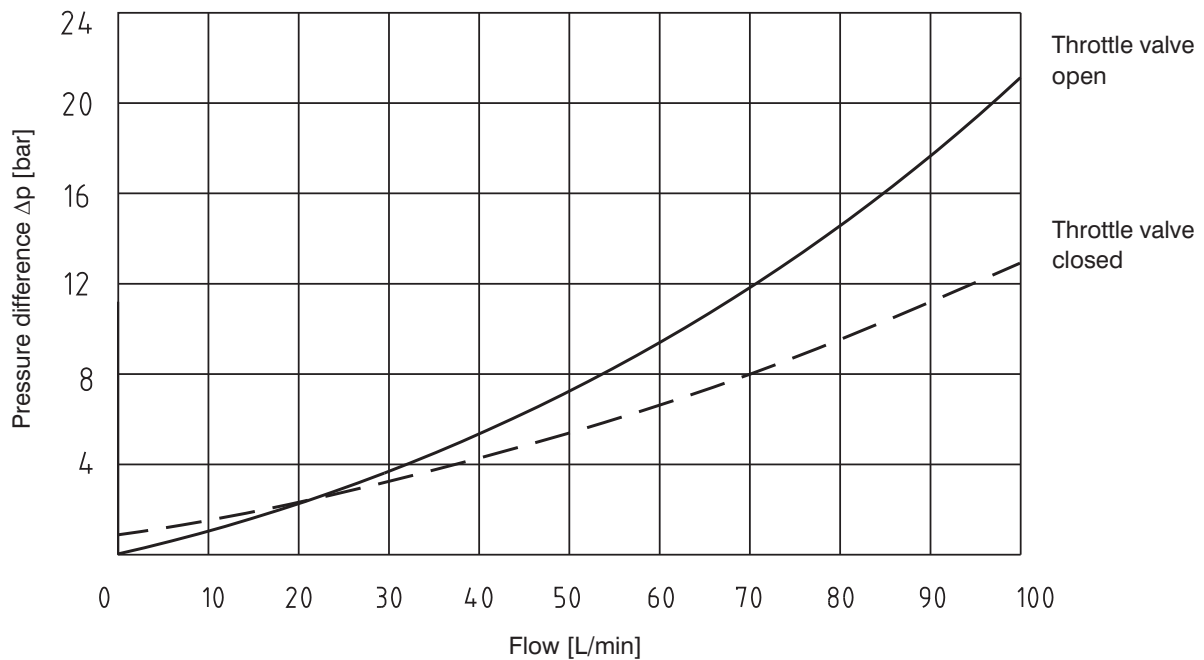

Spare Parts

Seal kit

Type	Dimensions, quantity		Ordering number
	O-ring	Square ring	
Standard NBR70	-	12.42x1.68 (5 pcs.)	15991600
Viton	12.42x1.68 (5 pcs.)	-	22943800

Valve Dimensions

Dimensions in millimetres

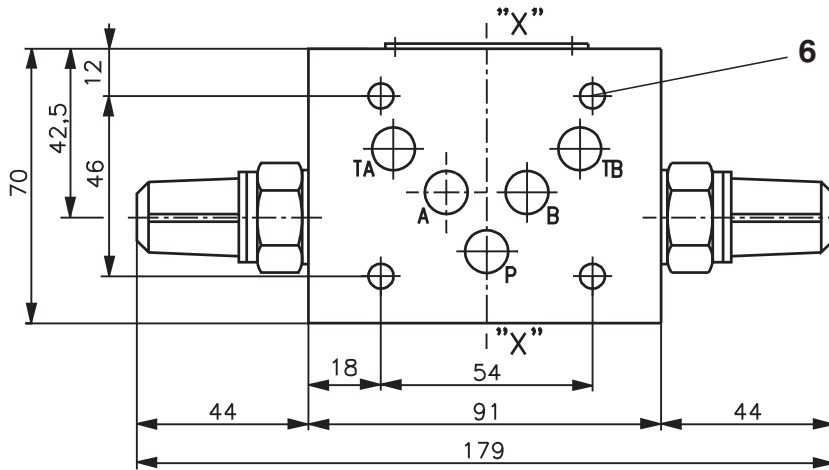

VSO2-10/MCS

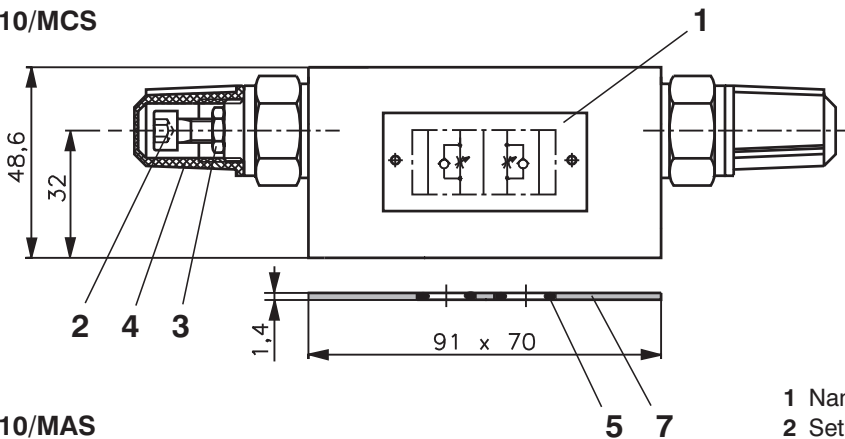

VSO2-10/MAS

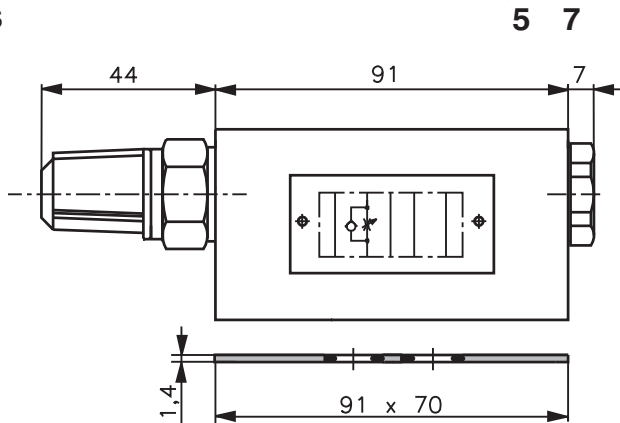

- 1 Name plate
- 2 Set screw with inside HEX 5
Clockwise rotation = flow increase
Counterclockwise rotation =
= flow decrease
- 3 Lock nut HEX 10
- 4 Protective cap
- 5 Sealing ring (5 pcs.)
Standard (NBR) R 014S 12.42 x 1.68
Viton (FPM) 12.42 x 1.78
supplied in each delivery packet
- 6 4 mounting holes (∅ 6.4 mm)
- 7 O-ring plate

Turning the valve around the x-axis changes the meter-out control mode into the meter-in one.

VSO2-10/MBS

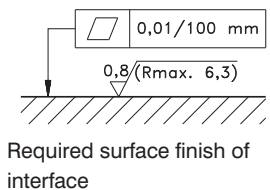
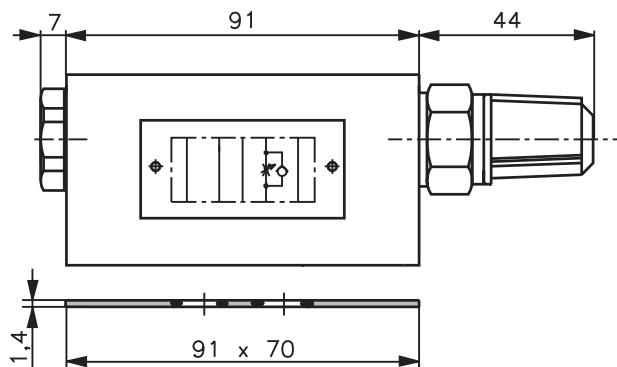

Required surface finish of interface

ARGO-HYTOS s.r.o. CZ - 543 15 Vrchlaví
Tel.: +420-499-403111, Fax: +420-499-403421
E-mail: sales.cz@argo-hytos.com
www.argo-hytos.com

- Wide range of throttling orifices
- Two models:
 - cartridge
 - screw-in cartridge valve

VSK4

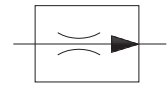

VSK2

Functional Description

The pressure compensated flow control valves VSK are designed to control flow rates practically independent of pressures and temperatures. The set up flow rate is constant and depends on the orifice area. The 2-way flow control valves can be used in meter-in, meter out or bleed-off applications.

The valve consists of housing (1), throttling orifice (2), pressure compensator (3), spring (4) and adjustment screw (5).

Throttling in the direction $A \rightarrow B$ takes place on the throttling area of the orifice (2). To provide for the independence between flow rate and pressure, a pressure compensator (3) with the metering edge (6) is located behind the throttling orifice. The spring (4) pushes the compensator to its extreme right position. Provided that there is flow passing through the valve, the input pressure acts on the face area of the pressure compensator and shifts it to the left, thus reducing the flow area of the metering edge (6) which results in decreasing the pressure difference at the throttling orifice. The movement of the compensator stops as soon as the equilibrium is reached and the pressure difference returns to its required value. The pressure compensator continuously compares the pressure difference at the orifice area (2) with the value preset by the spring pretension and ensures the necessary control, thus holding the flow rate constant. The flow rate of the VSK2 can be adjusted in a small range by setting the adjustment screw (5).

The flow rate in direction $B \rightarrow A$ is also given by the orifice area (2), but the function of the pressure compensator is excluded.

The function of the VSK4 is similar, but in this case, the pressure compensator (3) is located in front of the throttling orifice (2).

The housing of the VSK2 valve does not have any surface treatment, the housing of the VSK4 is phosphate coated. All the other parts are zinc coated.

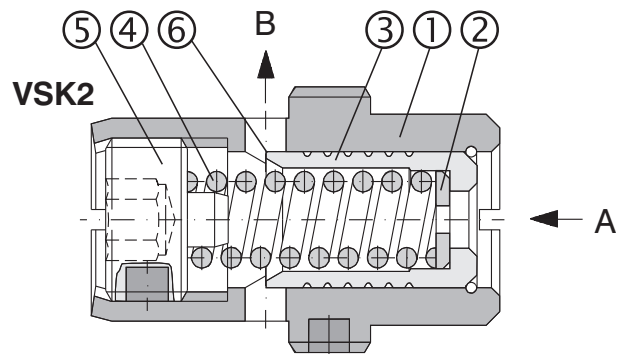

VSK4

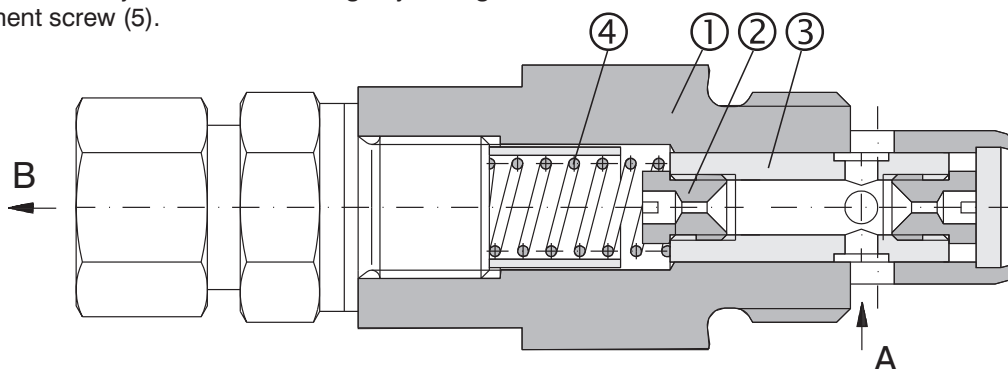

Ordering Code

VSK - - /

Constant Flow-Control Valve

Model

Cartridge

2

Screw - in cartridge

4

no designation

Type

Standard

Connectiong thread

Metric thread (M18x1.5 for VSK2)

M2

Metric thread (M22x1.5 for VSK4)

M4

Pipe thread (G 3/8 only for VSK2)

G4

Orifice diameter in mm/100

VSK2	55	80	100	-	120	-	-	-	-	160	180	-	210	230	-	260
VSK4	-	-	100	110	120	130	135	140	150	160	180	200	-	-	250	-

Technical Data

Nominal size	mm	06
Maximum flow	L/min	See table of flow rates
Maximum working pressure	bar	320
Minimum pressure difference	bar	See the performance curves
Hydraulic fluid	Hydraulic oils of power classes (HL, HLP) to DIN 51 524	
Fluid temperature range for (NBR)	°C	-30 ... +100
Viscosity range	mm ² /s	20 ... 400
Maximum degree of fluid contamination	Class 21/18/15 to ISO 4406	
Weight - VSK2	kg	0,025
VSK4 with connector		00,2
Mounting position	unrestricted	

Approximate flow rates corresponding with the orifice diameter

VSK2		VSK4	
ID of the orifice [mm/100]	Flow range L/min adjustable through spring pretension at 32 bar	ID of the orifice [mm/100]	Flow range L/min an input presure 32 bar
55	0,3 - 0,6	100	2,1
80	1,4 - 1,7	110	2,4
100	1,8 - 2,4	120	3,0
120	3,1 - 4,0	130	3,8
160	5,5 - 6,5	140	4,3
180	5,6 - 7,1	150	4,9
210	8,5 - 10,8	160	6,3
230	10,7 - 13,3	180	6,6
260	12,0 - 16,4	200	8,7
		250	12,5
		135/S	6,0

Δp-Q Characteristics (B → A)

Measured at $v = 32 \text{ mm}^2/\text{s}$

VSK2

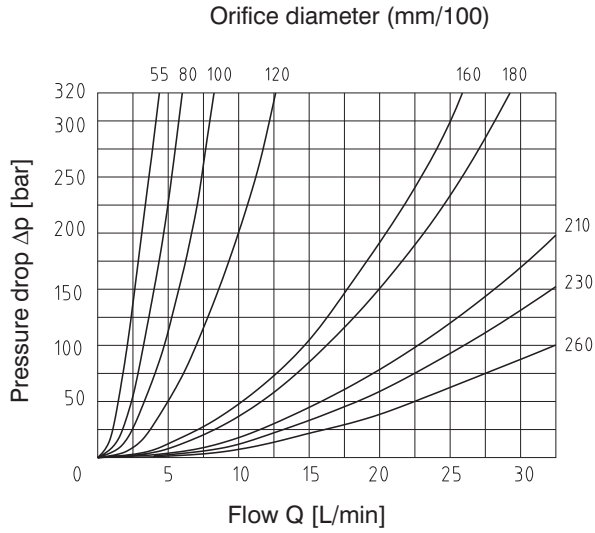

VSK4

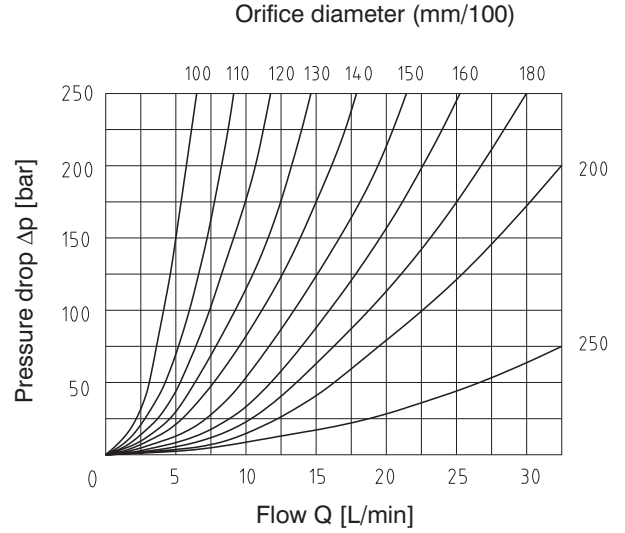

Δp-Q Characteristics (A → B)

Measured at $v = 32 \text{ mm}^2/\text{s}$

VSK2

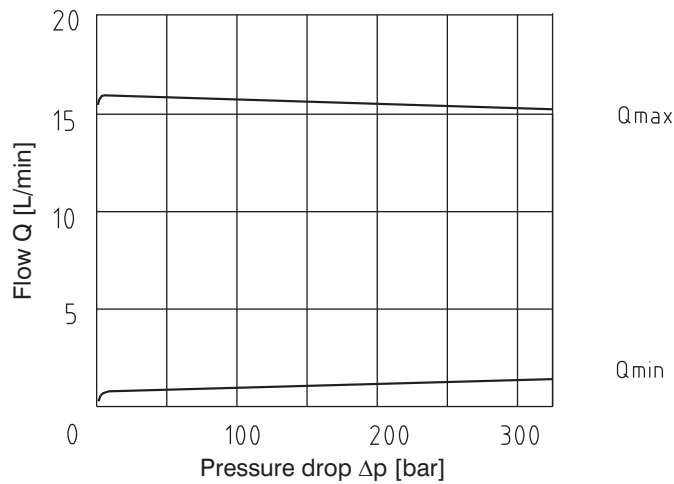

VSK4

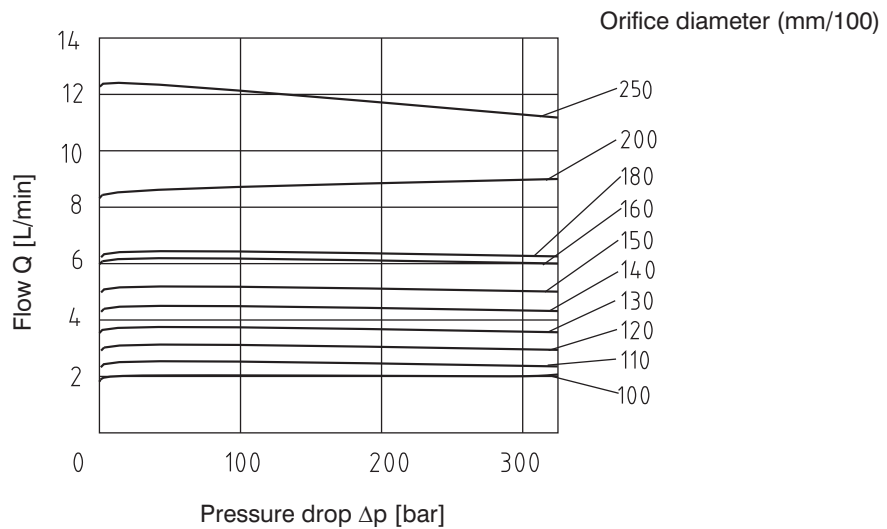

4

Valve Dimensions

Dimensions in millimeters

VSK2-M4-x

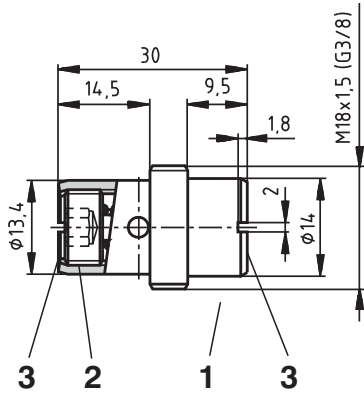

Cavity

Controlled flow

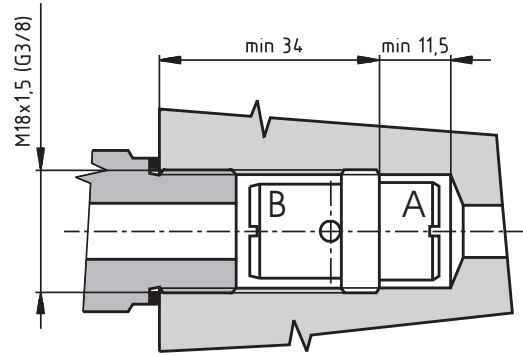
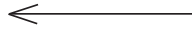

Controlled flow

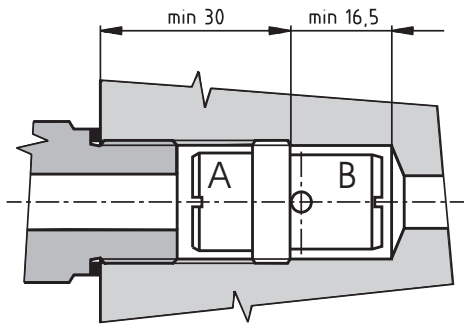

- 1 Type designation (stamped)
- 2 Screw for fine flow adjustment (with VSK2 only)
 - inside HEX5
 - anti clockwise rotation = flow decrease
 - clockwise rotation = flow increase
- 3 Slot for screwing-in in mounting cavity of VSK2
- 4 Straight connector GE10-PRL-ED for pipe with $\varnothing D$ 10 mm
- 5 Wrench flats size 22 mm, tightening torque $Md = 30$ Nm
- 6 Sealing edge

VSK4-M4-x

Cavity

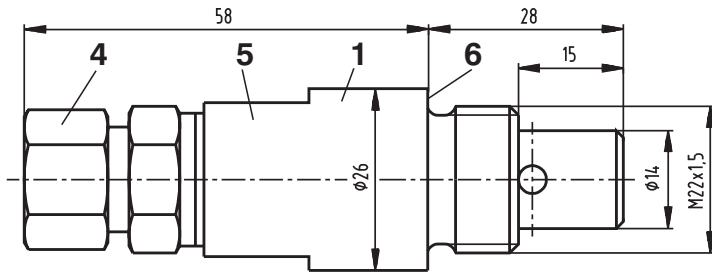

Controlled flow

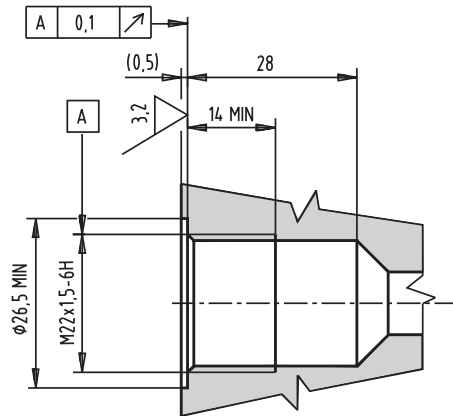

Caution!

- The packing foil is recyclable.
- The technical information regarding the product presented in this catalogue is for descriptive purposes only. It should not be construed in any case as a guaranteed representation of the product properties in the sense of the law.

ARGO-HYTOS s.r.o. CZ - 543 15 Vrchlaví
 Tel.: +420-499-403111, Fax: +420-499-403421
 E-mail: sales.cz@argo-hytos.com
 www.argo-hytos.com

- Sandwich plate design for use in vertical stacking assemblies
- For use in meter-in, meter-out or bleed-off applications
- Available with reverse free-flow check valve
- Flow rate setting with adjustment knob
- Installation dimensions to ISO 4401-AB-03-4-A and DIN 24 340 -A6
- Subplates - see catalogue HA 0002

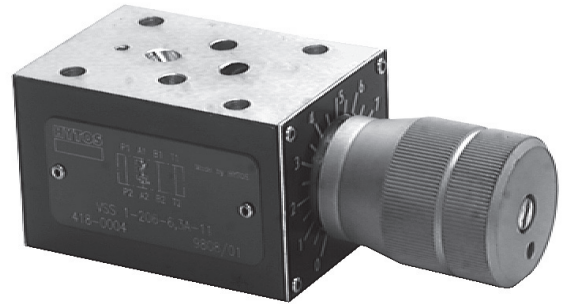
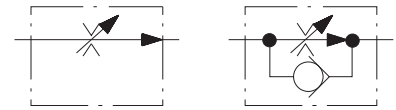

Functional Description

Pressure compensated flow control valves are designed to provide adjustable controlled flow rates independent of changes in inlet and/or outlet pressure.

2 way valves are used in meter-in, meter-out or bleed-off and or parallel applications.

The flow control valve consists basically of housing (1), throttling spool (2), spring (3), pressure compensator (4) and a hand knob (5) with adjustment mechanism.

Flow control valve VSS1-206-A

Fluid from port A1 passes through orifice area (6) of the throttling spool, proceeds through its internal bore to the orifice area (7) modulated via the metering edge of the pressure compensator (4) and onwards to port A2. The flow rate depends on the orifice area (6) and is determined by rotating the adjustment knob (5). The knob can be fixed at the adjusted position via tightening screw (9). The spring pushes both the throttling spool and the spool of the pressure compensator to their extreme positions and provided that there is no flow through the valve, holds the orifice area (7) fully open. An introduction of flow to port A1 exposes inlet pressure through bore (8) to the bottom area of the compensator spool and causes this spool to move in closing direction, thus decreasing the pressure difference at the orifice area (6) of the throttling spool. The movement of the

compensator stops as soon as a new equilibrium is reached. The pressure compensator compares continuously the pressure difference at the orifice area (6) with the amount preset by the spring pretension and modulates the orifice area (6) accordingly, thus holding the flow rate constant.

Flow control valve VSS1-206-B

This type of valve functions on the same principle as the previous one, however, reverse free-flow from port A2 to port A1 is provided for by the built-in check valve. Connection of port A1 with port P1 is ensured by cover plate or by directional valve situated at the upper face of housing (1) - see Functional symbols (vertical stacking assemblies).

Flow control valve VSS1-206-C

This valve has the same function as the valve described above, the only difference being the changed flow direction, i.e. controlled flow in direction A2 → A1 and free-flow in direction A1 → A2.

The basic surface treatment of the valve housing is phosphate coated, whereas the surface of the other parts are zinc coated.

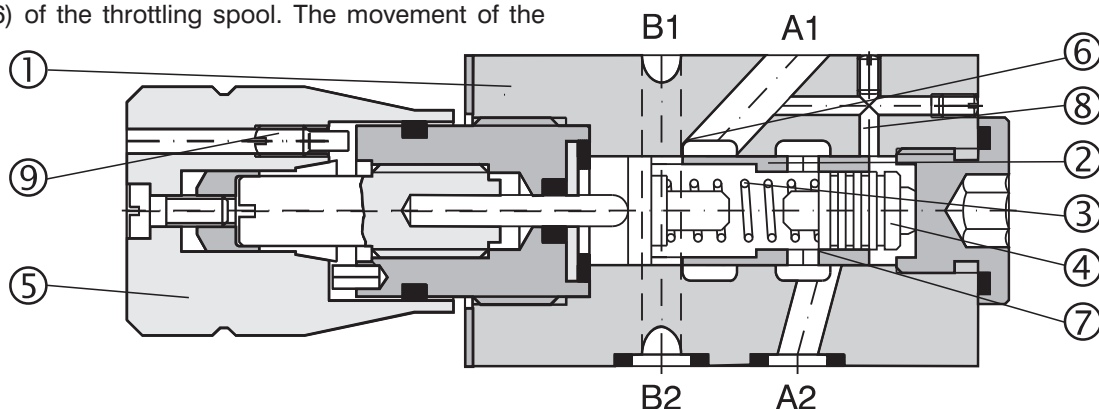

Ordering Code

VSS1-206-

Flow Control Valve

2 way design

Nominal size

Flow rate L/min

Q = 6,3

Q = 12

Q = 22

6,3

12

22

no designation
V

Seals

NBR

Viton

Model

A-02

for subplate mounting - without check valve

A-11

sandwich plate design - without check valve

B-11

sandwich plate design - with check valve,

meter-in mode

C-11

sandwich plate design - with check valve,

meter-out mode

4

Functional Symbols

A - without check valve

Model A-02

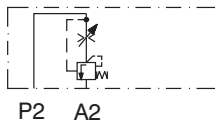

Model A-11

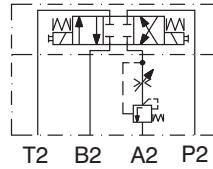
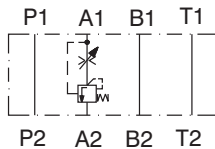

Typical application of the valve in stacking assembly *

B - with check valve, meter-in mode

Model B-11

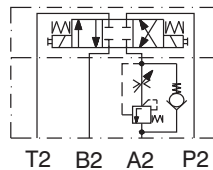
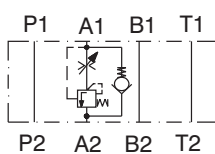

Typical application of the valve in stacking assembly *

C - with check valve, meter-out mode

Model C-11

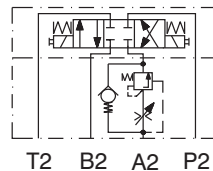
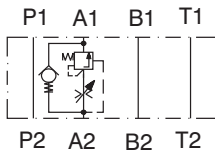

Typical application of the valve in stacking assembly *

* Directional valve must be ordered separately.

Technical Data

Nominal size	mm	06		
Maximum flow rate	L/min	6,3	12	22
Minimum flow rate	cm ³ /min	60		
Max. operating pressure	bar	320		
Minimum pressure drop	bar	see performance curves		
Hydraulic fluid		Hydraulic oils of power classes (HL, HLP) to DIN 51524		
Fluid temperature range for (NBR)	°C	-30 ... +100		
Fluid temperature range for (Viton)	°C	-20 ... +120		
Viscosity range	mm ² /s	20 ... 400		
Maximum degree of fluid contamination for Q ≤ (1 L/min) for Q > (1 L/min)		Class 20/17/14 according to ISO 4406 Class 21/18/15 according to ISO 4406		
Weight	kg	0.8		
Mounting position		unrestricted		

Characteristics

Measured at $v = 32 \text{ mm}^2/\text{s}$

Flow rate dependent upon scale adjustment setting
(flow control P → A)

Flow rate dependent upon pressure

Model

VSS1-206-6.3x-xx

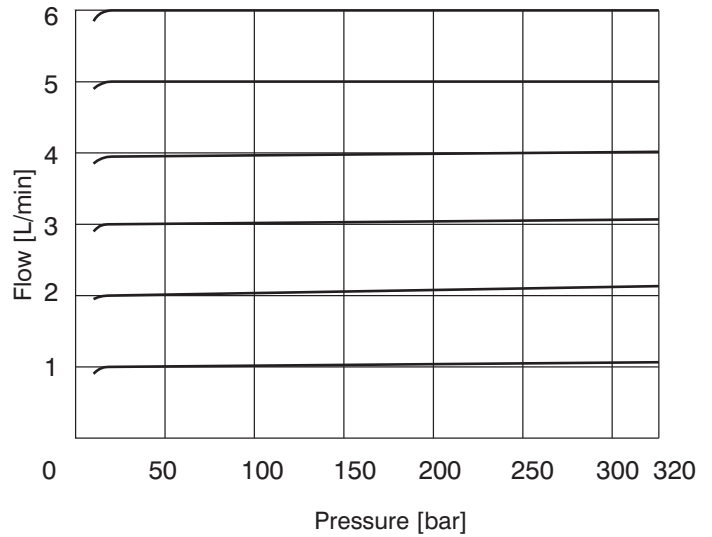
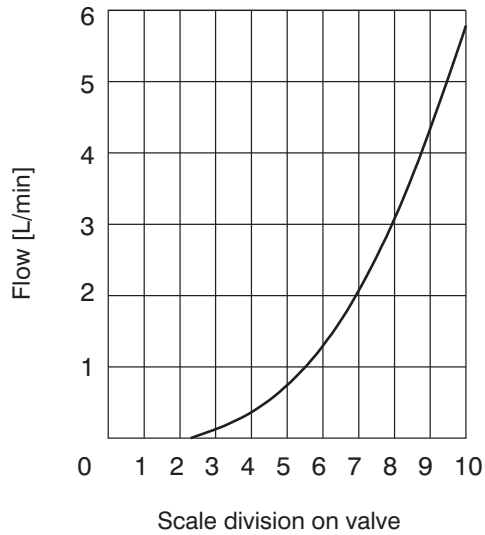

Model

VSS1-206-12x-xx

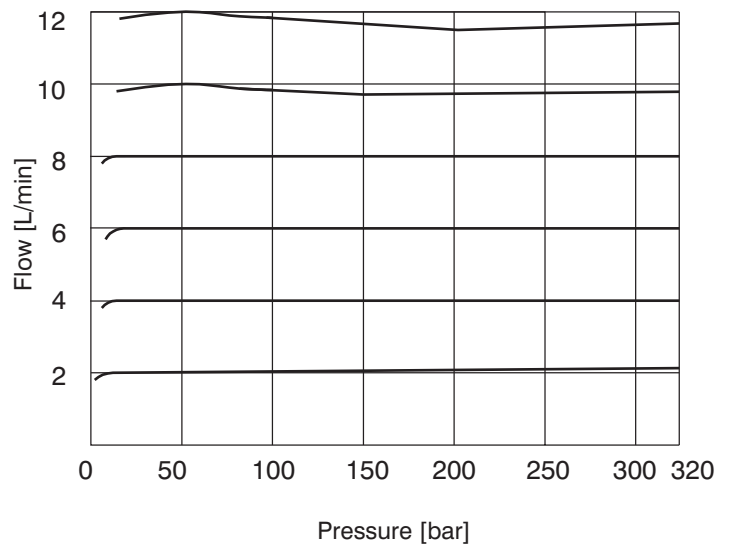
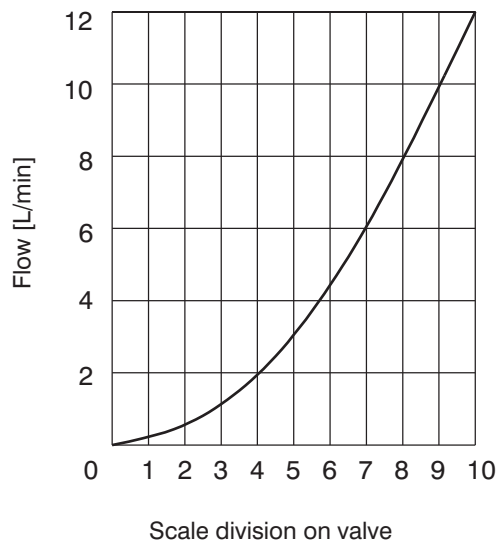

4

Characteristics

Measured at $v = 32 \text{ mm}^2/\text{s}$

Flow rate dependent upon scale adjustment setting
(flow control P → A)

Flow rate dependent upon pressure

Model
VSS1-206-22x-xx

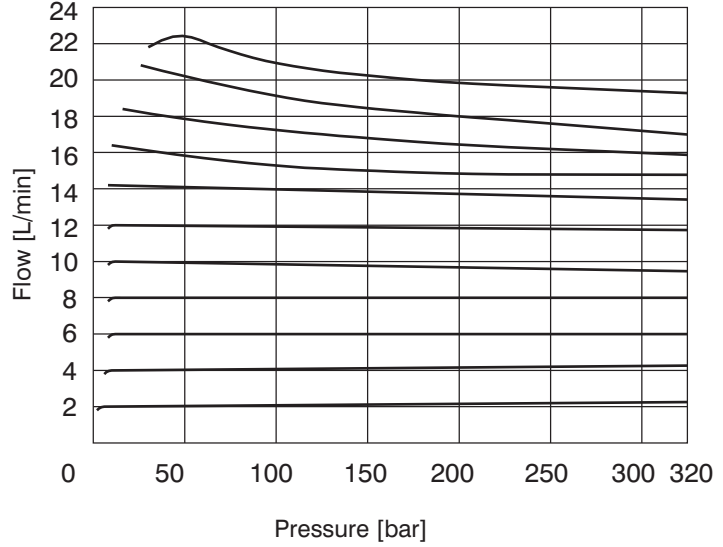
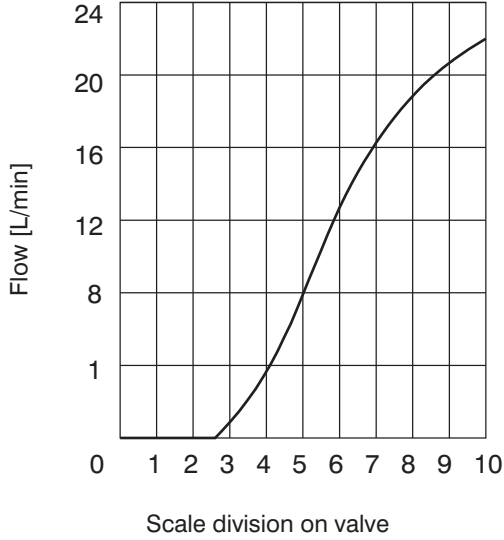

4

Δp-Q Characteristics

Measured at $v = 32 \text{ mm}^2/\text{s}$

Check valve
Pressure difference Δp related to flow from (A → P)

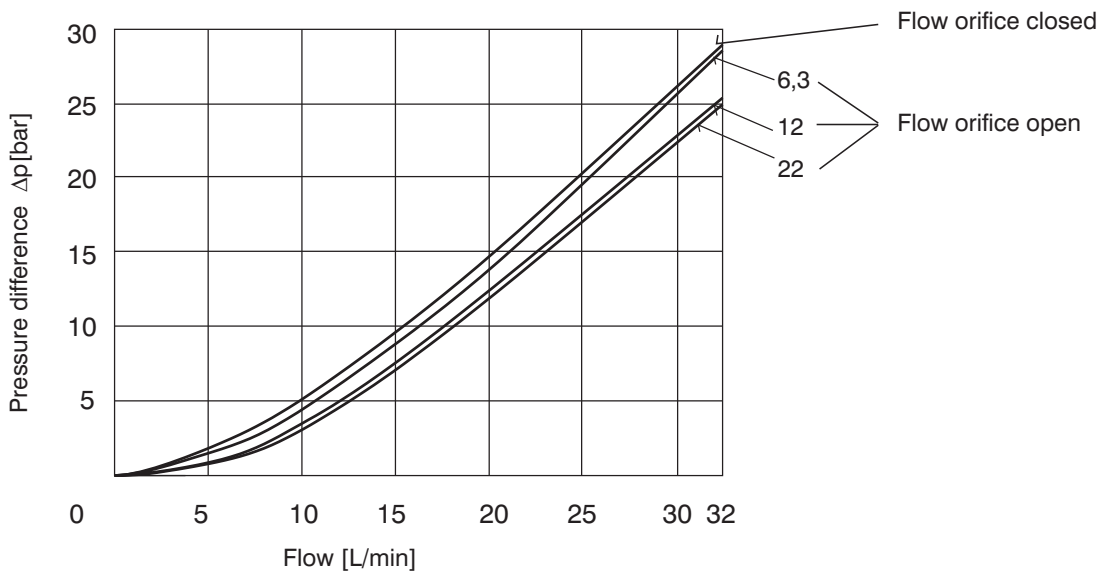

Valve Dimensions

Dimensions in millimetres

Models A-11, B-11, C-11

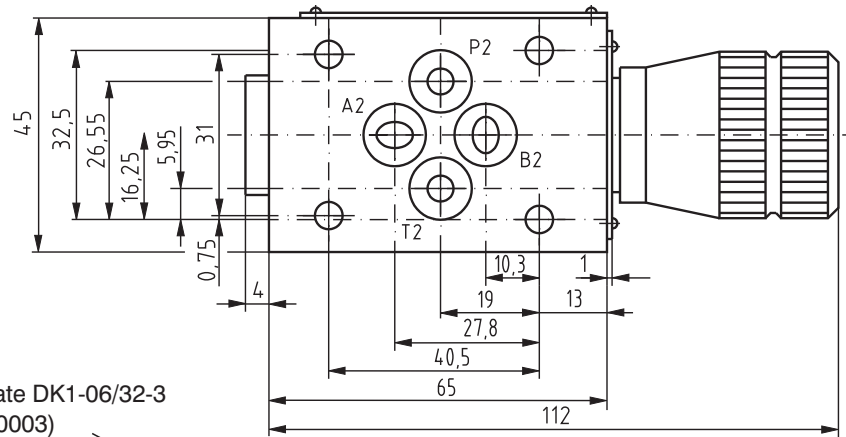

Cover plate DK1-06/32-3
(see HA 0003)

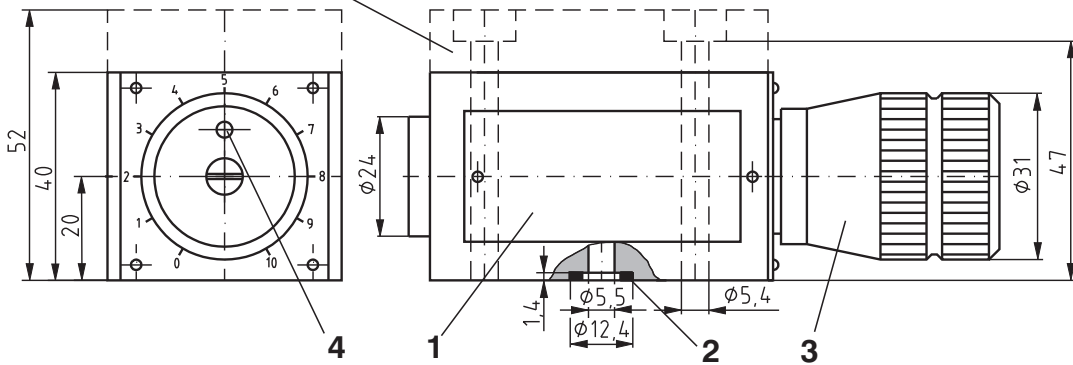

Models A-02

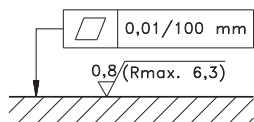
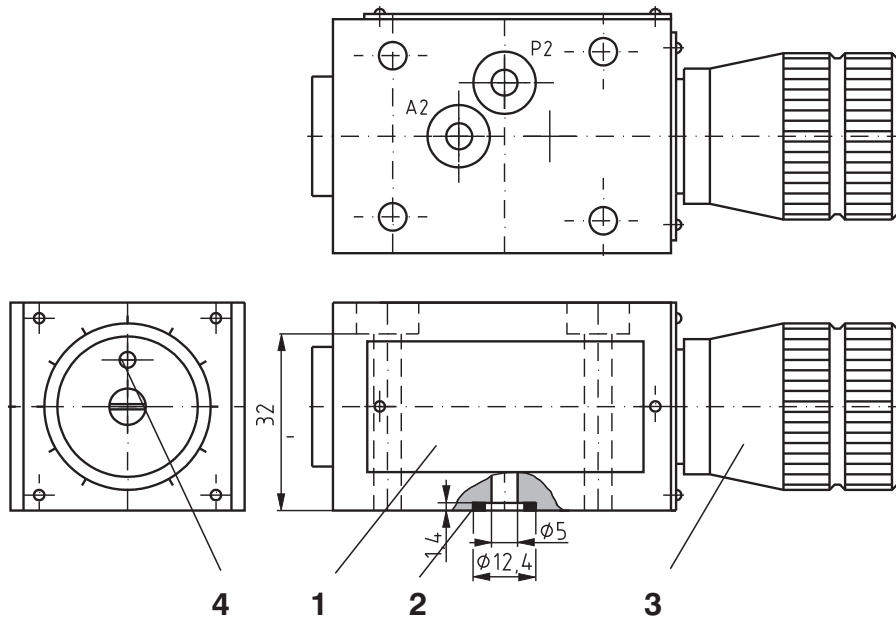

Required surface finish of interface

- 1 Name plate
- 2 O-rings, Type Square ring 012 (9.25x1.68) (4pcs.) or compatible supplied in delivery packet
- 3 O-rings, Type Square ring 012 (9.25x1.68) (2pcs.) or compatible supplied in delivery packet
- 4 Adjustment mechanism:
clockwise rotation - flow decrease
counter-clockwise rotation - flow increase
- 5 Hole with set screw for fixing the handknob in set position

Spare Parts

Seal kit

Type	Dimensions, quantity		Ordering number
	Square ring	O-ring	
Standard NBR 70	9,25 x 1,68 (4 pcs.)	-	15608800
Viton	-	9,25 x 1,78 (4 pcs.)	22795200

4

Caution!

- The packing foil is recyclable.
- The transport plate is to be returned to the supplier.
- The technical information regarding the product presented in this catalogue is for descriptive purposes only. It should not be construed in any case as a guaranteed representation of the product properties in the sense of the law.

ARGO-HYTOS s.r.o.. CZ - 543 15 Vrchlabí
 Tel.: +420-499-403111, Fax: +420-499-403421
 E-mail: sales.cz@argo-hytos.com
 www.argo-hytos.com

- 2 way pressure compensated flow control valve with integral reverse check valve
- Subplate mounting
- Flow rate setting:
 - with adjustment knob
 - with adjustment knob and keylock
- For use in meter-in, meter-out or bleed-off applications
- External pilot closing of pressure compensator
- Installation dimensions to ISO 4401-03-02-0-94 and DIN 24 340-A6
- Subplates - see catalogue HA 0002

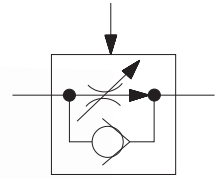

Functional Description

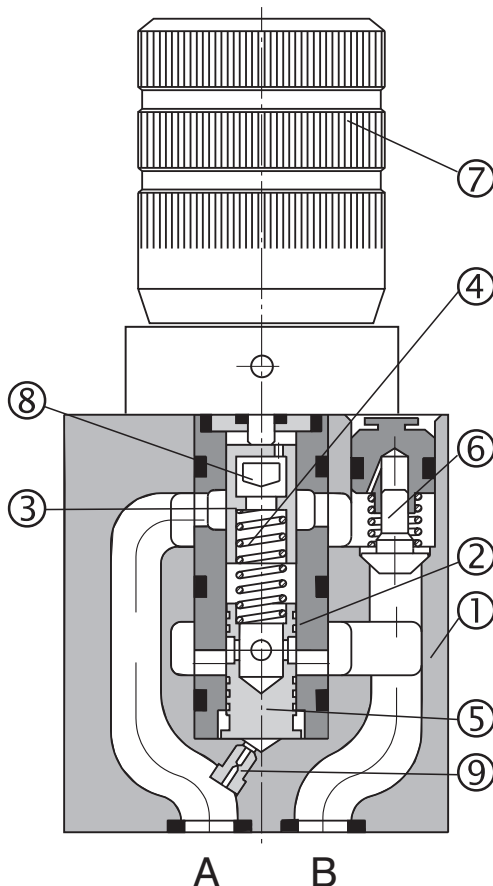

Pressure compensated flow control valves VSS2-062 are designed to provide adjustable controlled flow rates independent of changes in pressure and temperature.

They consist basically of housing (1), sleeve (2), throttling spool (3), spring (4), pressure compensator (5) and hand knob (7) with the respective setting mechanism.

The valve housing is phosphate coated.

Flow control valve VSS2-062-xxQ/Jx0-1

(without external pilot closing of pressure compensator)

Flow throttling in direction A → B takes place at the throttling area (8) which can be adjusted by hand knob (7). To ensure the flow rate stability in port B, a pressure compensator (5) is located behind the throttling area (8).

The spring (4) pushes both the throttling spool (3) and the pressure compensator (5) into their extreme positions, and provided that there is no flow through the valve, holds the pressure compensator open.

An introduction of flow to port A exposes inlet pressure through orifice (9) to the bottom area of the compensator spool and causes this spool to move in closing direction, thus decreasing the pressure difference at the throttling area (8). The movement of the compensator spool stops as a new equilibrium is reached. The pressure compensator compares continuously the pressure difference at the throttling area (8) with the amount preset by the spring preloading and accomplishes the required control, thus holding the flow rate constant.

Flow control valve VSS2-206-x/JxA-1
(with external pilot closing of pressure compensator)

This model functions on the same principle as the previous one. However, with this type of valve, the bottom surface area of the compensator is connected to an external port P via orifice (10), rather than being internally connected to port A. This arrangement enables external pilot closing of pressure compensator, which function can be described using the circuit diagram shown.

When there is no flow through the valve (directional valve (11) in its middle position), pressure in port P acts at the bottom area of the compensator via orifice (10) and holds the compensator in its upper closed position. When the directional valve is shifted to its left position, the port A is connected to the system pressure, but the closed compensator avoids abrupt flow increase in port B. Hence, lunge of the actuator during start-up is prevented. The function of the compensator is the same, as the function described above.

This model with external pilot closing of the compensator can only be used in meter-in circuits.

Reverse free-flow from port B to port A, with both types of the flow control valves, is provided for by a built-in check valve (6).

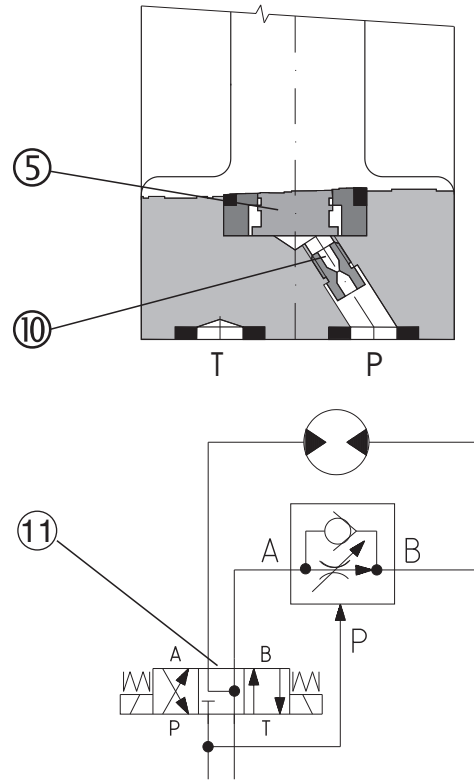

4

Ordering Code

VSS2-206- [] /J [] [] -1 []

Flow Control Valve

2 way design

Nominal size

Max. flow rate in L/min

0,6	0,6Q
1,6	1,6Q
3,2	3,2Q
6,3	6Q
16	16Q
32	32Q

Built-in check valve

no designation
V

Seals
NBR
FPM (Viton)

Design

Variant
A with external pilot closing of the pressure compensator
O without external pilot closing of the pressure compensator

Adjustment
Z hand knob with keylock
O hand knob without keylock

Functional Symbols

Flow control valve: simplified

without external pilot

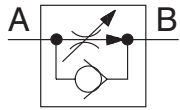

with external pilot

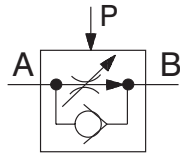

Flow control valve: detailed

without external pilot

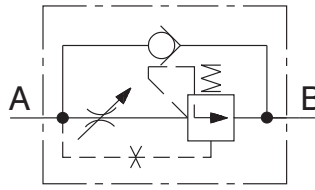

with external pilot

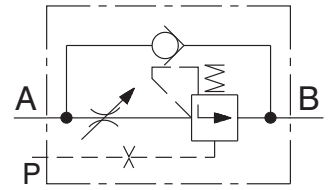

Technical Data

Nominal size	mm	06					
Maximum flow	L/min	0,6	1,6	3,2	6,3	16	32
Minimum flow	cm ³ /min	10	15	20	25	60	250
Maximum working pressure at port A	bar	320					
Maximum working pressure at port B	bar	320					
Pressure drop	bar	8.5 ... 14					
Hydraulic fluid		Hydraulic oils of power classes (HL, HLP) to DIN 51524					
Fluid temperature range for (NBR)	°C	-30 ... +100					
Fluid temperature range for (Viton)	°C	-20 ... +120					
Viscosity range	(mm ² /s)	20 ... 400					
Maximum degree of fluid contamination - for Q ≤ 1 L/min - for Q > 1 L/min		Class 20/17/14 to ISO 4406 Class 21/18/15 to ISO 4406					
Permissible flow rate variation for Q > 2.5 Q _{min} at pressure change 6 to 100%	%	± 5					
Weight	kg	1.1					
Mounting position		unrestricted					

Spare Parts

Seal kit

Type	Dimensions, quantity		Ordering number
	Square ring	O-ring	
Standard NBR 70	9,25 x 1,68 (4 pcs.)	-	22795100
Viton	-	9,25 x 1,78 (4 pcs.)	22795200

Characteristics

Measured at $v = 32 \text{ mm}^2/\text{s}$

Flow rate A → B dependent upon scale adjustment setting

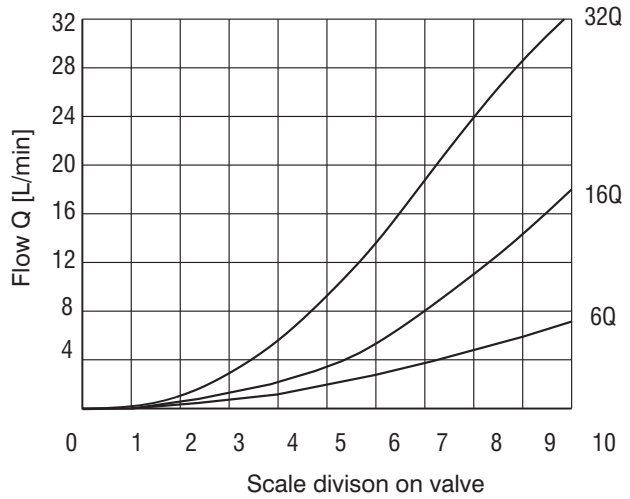
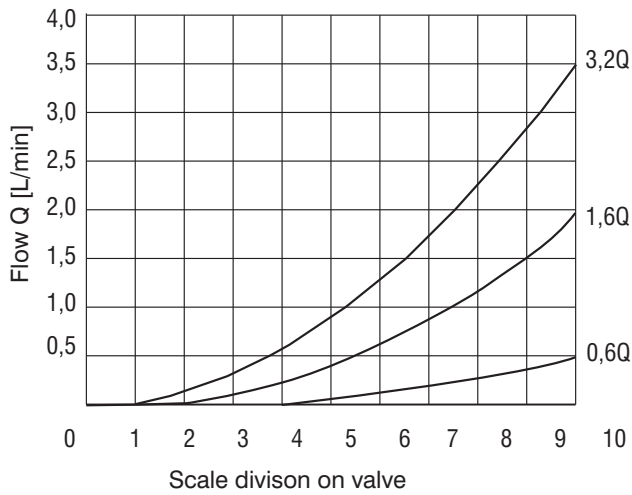

4

Δp -Q Characteristic

Measured at $v = 32 \text{ mm}^2/\text{s}$

Check valve

Pressure difference Δp related to flow from B → A

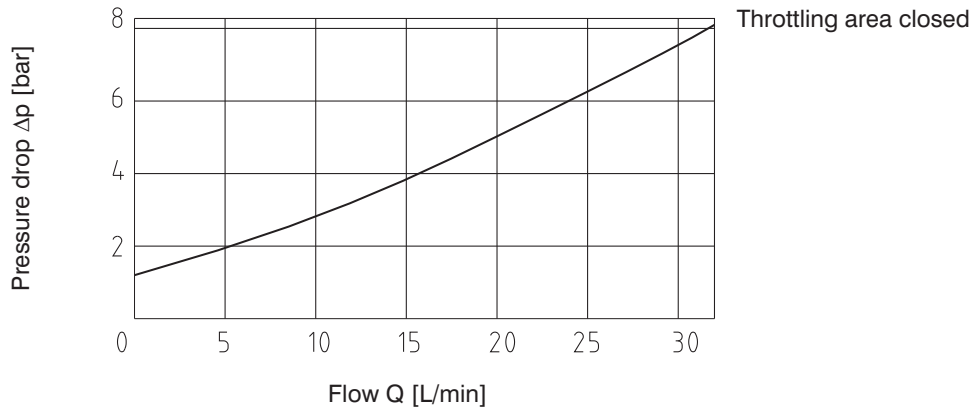

Dependency Flow-Temperature

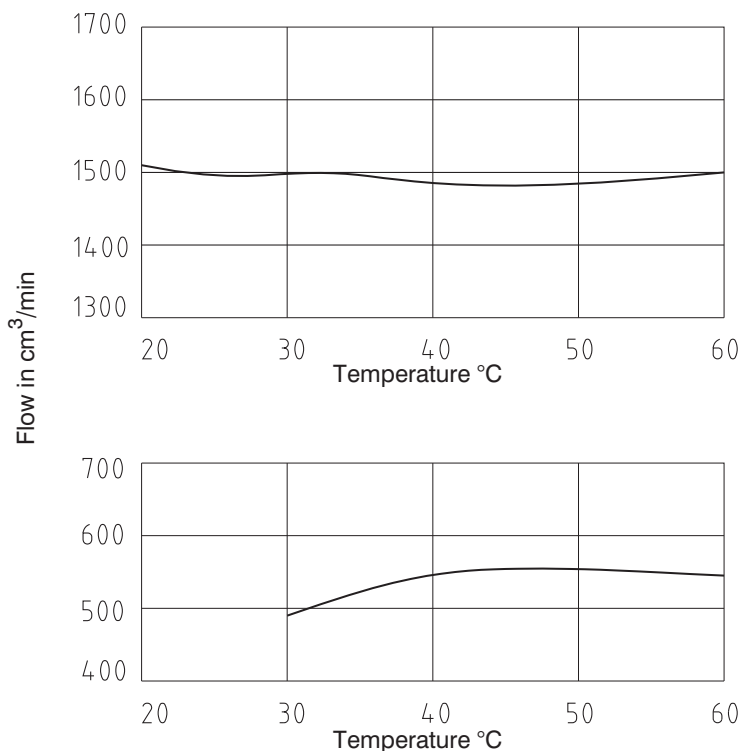

Characteristics Q = f(p)

Measured at $v = 32 \text{ mm}^2/\text{s}$

Flow rate dependent upon pressure

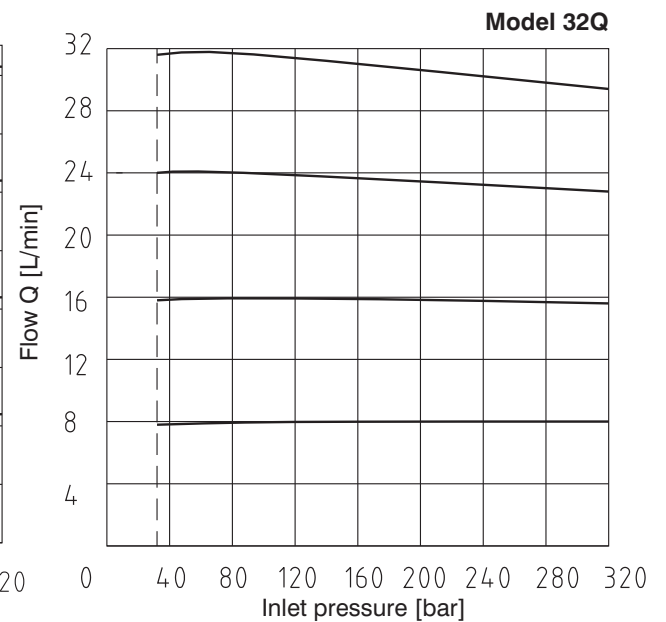
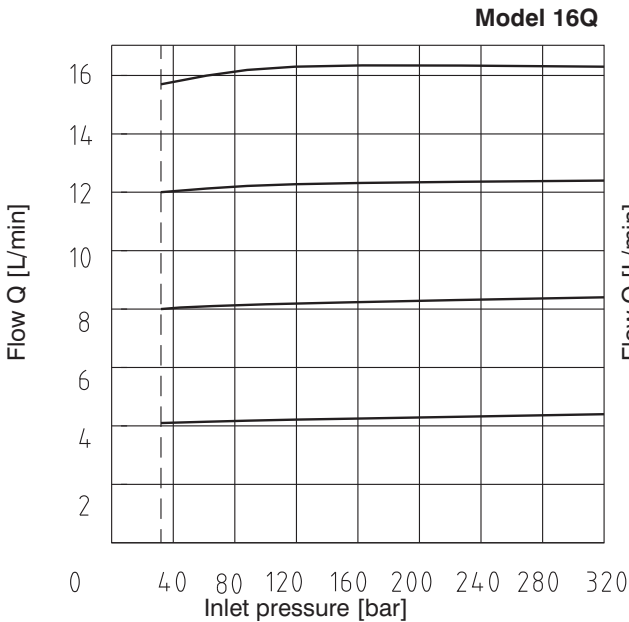
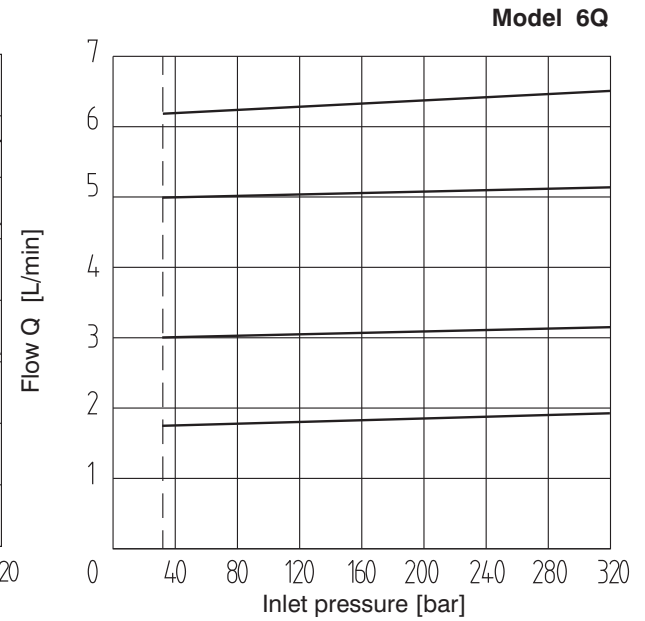
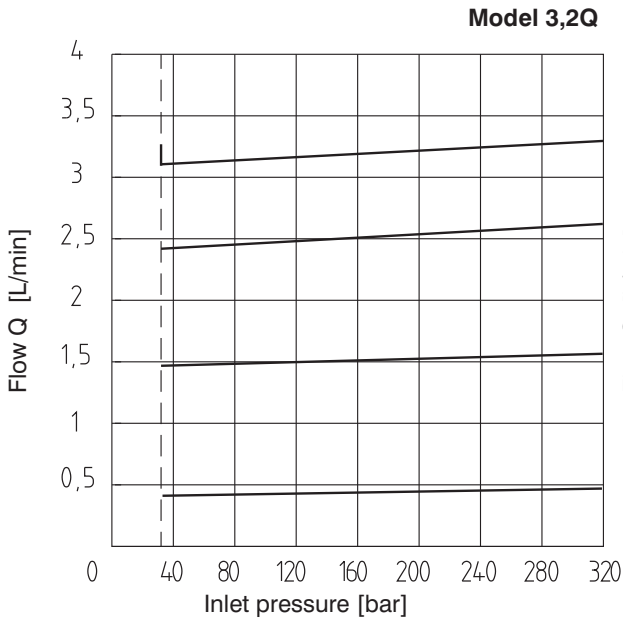
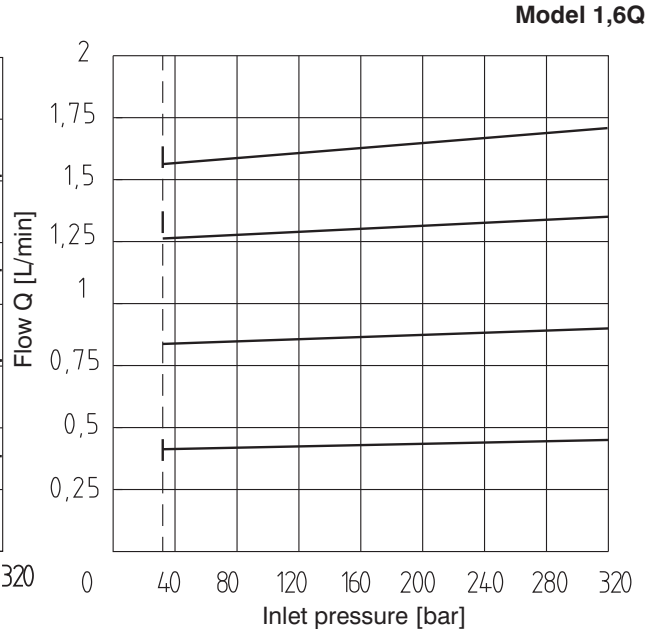
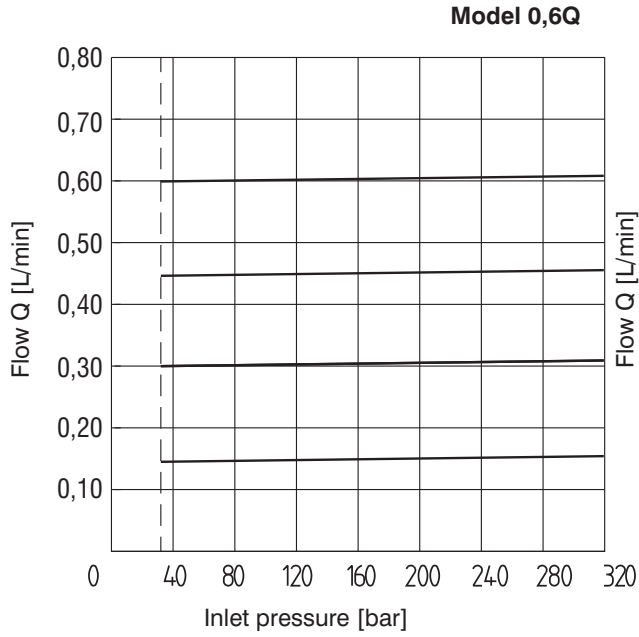

4

Valve Dimensions

Dimensions in millimeters

- 1 Port A (inlet)
- 2 Port B (outlet)
- 3 Port P (hole $\varnothing 5.2$ mm solely with type permitting external closing of the compensator, otherwise just the counterbore for O-ring)
- 4 Counterbore for O-ring (position for T port)
- 5 Name plate
- 6 Square ring 012 - KANTSEAL (4 pcs.) (9.25x1.68 NBR70)
- 7 Flow adjustment knob
- 8 Height of the valve with hand knob without keylock
- 9 Height of the valve with hand knob with keylock
- 10 Distance required to remove the key

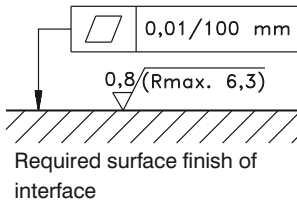
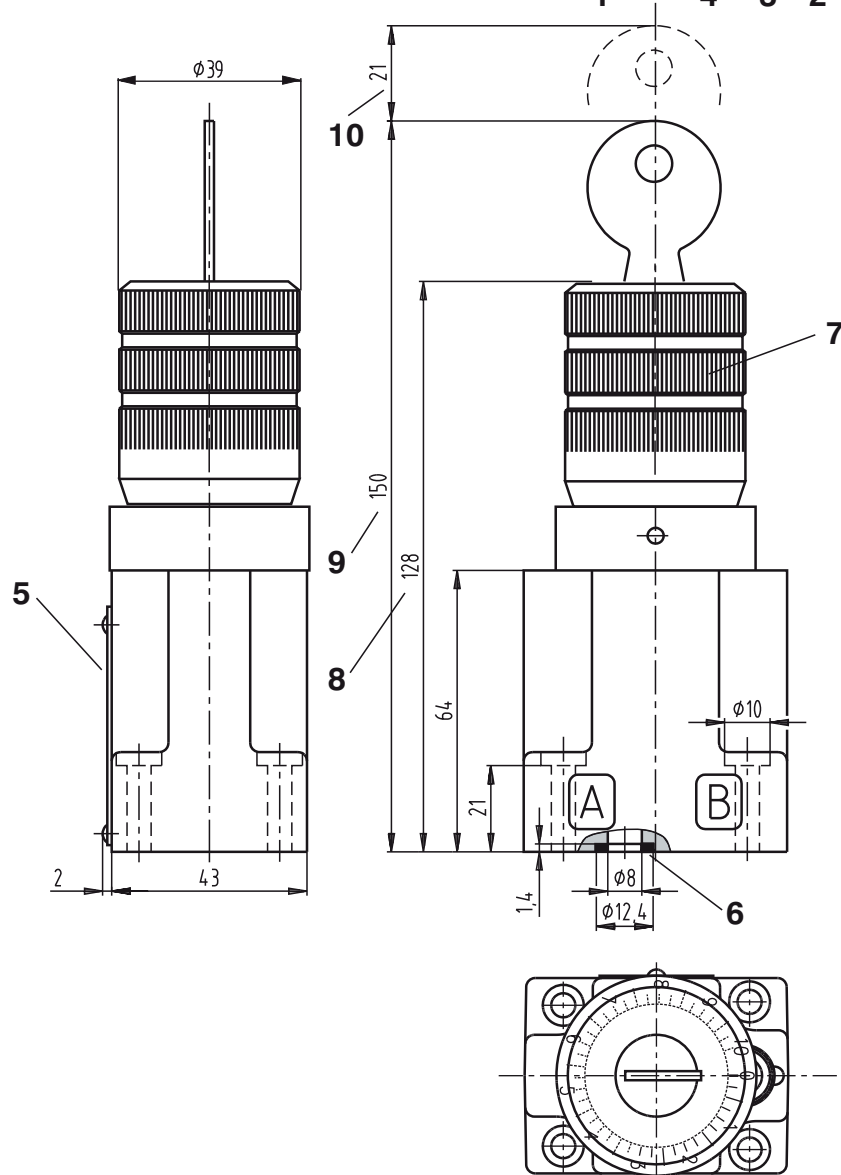
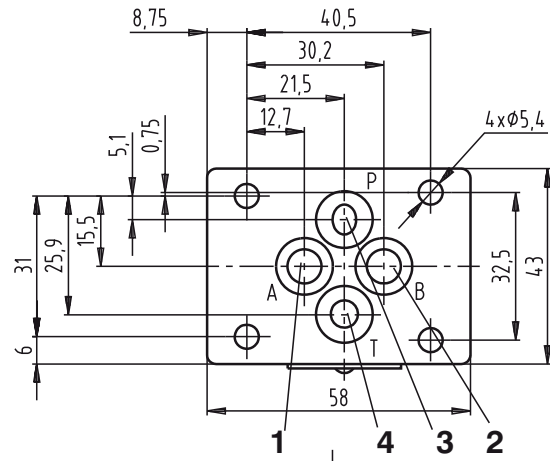

Caution!

- The packing foil is recyclable.
- Mounting bolts M5x30 DIN 912-10.9 (4 pcs.) must be ordered separately. Tightening torque of the bolts is 8.9 Nm.
- The technical information regarding the product presented in this catalogue is for descriptive purposes only. It should not be construed in any case as a guaranteed representation of the product properties in the sense of the law.

ARGO-HYTOS s.r.o. CZ - 543 15 Vrchlabí
 Tel.: +420-499-403111, Fax: +420-499-403421
 E-mail: sales.cz@argo-hytos.com
 www.argo-hytos.com

- 3 way pressure compensated flow control valve with integral reverse check valve
- Sandwich plate design for use in vertical stacking assemblies
- Flow rate setting with adjustment knob
- Installation dimensions to ISO 4401-03-02-0-94 and DIN 24 340-A6
- Subplates - see Data Sheet HA 0002

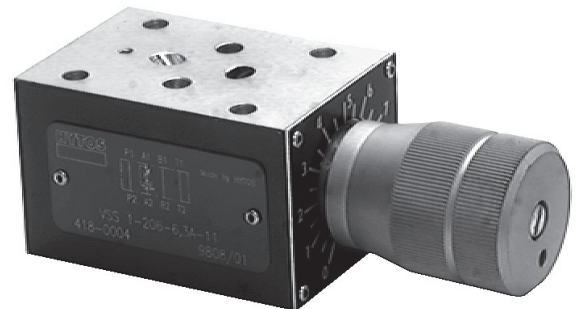
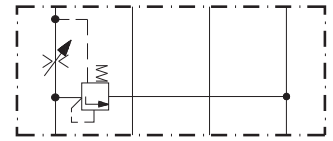

Functional Description

3 way pressure compensated flow control valves are designed to provide adjustable controlled flow rates independent of changes in system pressure.

The flow control valve consists basically of housing (1), throttling spool (2), pressure compensator (3), spring (4) and hand knob (5) with adjustment mechanism.

Fluid from port P2 is divided into two parts, one part of flow passes through orifice area (6) of the throttling spool and onwards through bore P to port P1, the other part proceeds through orifice area (7) of the compensator to port T. The flow rate depends on the

orifice area (6) and is determined by rotating the adjustment knob (5). The knob can be fixed at the set position via adjustment screw (8). The compensator compares continuously the pressure difference at the orifice area (6) with the amount preset by the spring pretension and modulates accordingly the orifice area (7) of the compensator which relieves the excessive flow to tank, thus holding the flow rate constant.

The valve housing is phosphate coated, the surfaces of the other parts are zinc coated.

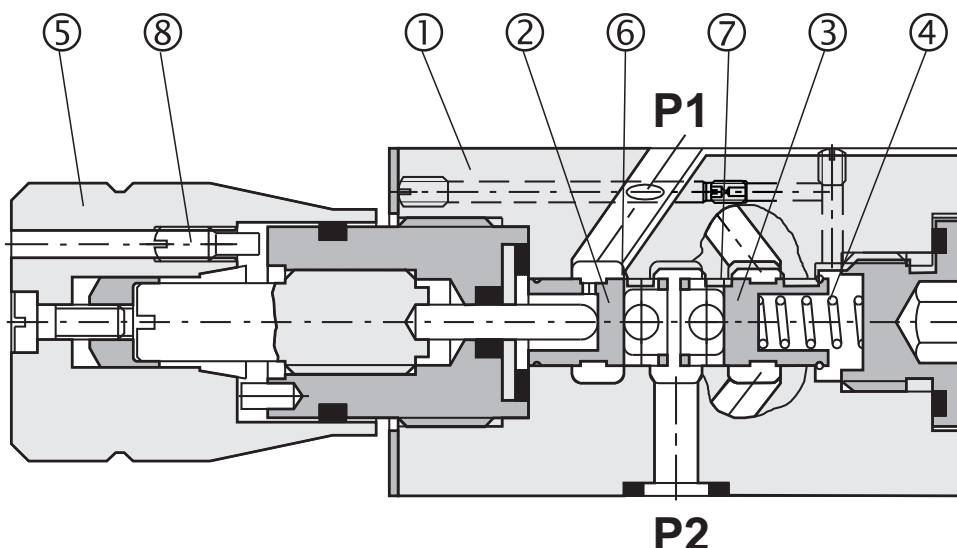

Ordering Code

VSS1-306-16-11

Flow Control Valve

3 way design

Valve size

no designation
V

Seal
NBR
FPM (Viton)

Sandwich plate design without cover plate

Flow rate
Q = 16 L/min

FOR PREFERRED TYPES SEE BOLD TYPING IN ORDERING CODE AND TABLE OF PREFERRED TYPES ON PAGE 3

4

Functional Symbols

Functional symbol of the valve

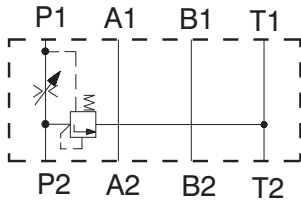

Typical application of the valve in stacking assembly*

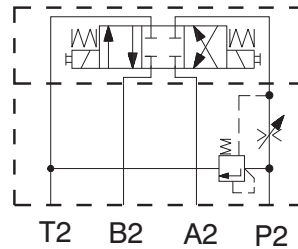

*Directional valve must be ordered separately

Technical Data

Valve size	mm	06
Maximum flow	L/min	16
Minimum flow	cm ³ /min	60
Maximum operating pressure	bar	320
Hydraulic fluid	Hydraulic oils of power classes (HL, HLP) to DIN 51524	
Fluid temperature range for (NBR)	°C	-30 ... +100
Fluid temperature range for (Viton)	°C	-20 ... +120
Viscosity range	mm ² /s	20 ... 400
Maximum degree of fluid contamination	Class 21/18/15 to ISO 4406	
Permissible flow rate variation at pressure change 6 ... 100%	%	± 10
Weight	kg	0.8
Mounting position	unrestricted	

Characteristics

Measured at $v = 32 \text{ mm}^2/\text{s}$

Flow rate dependent upon scale adjustment setting

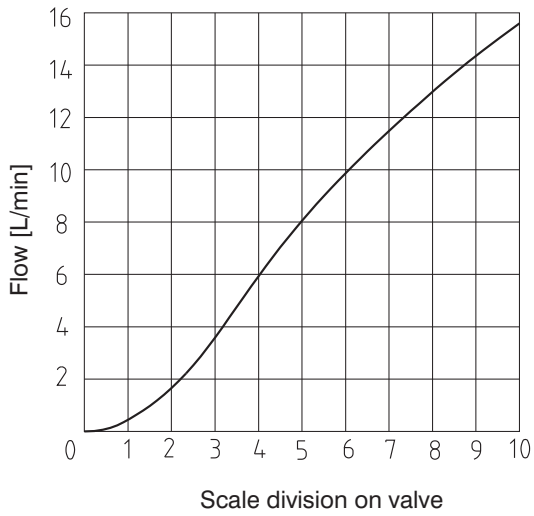

Flow rate dependent upon pressure

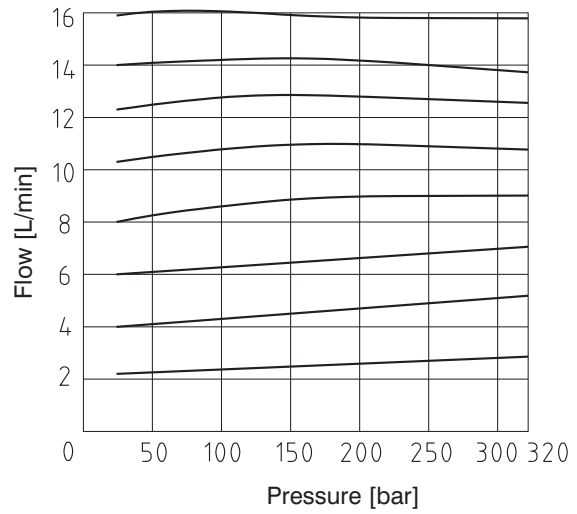

Valve Dimensions

Dimensions in millimeters

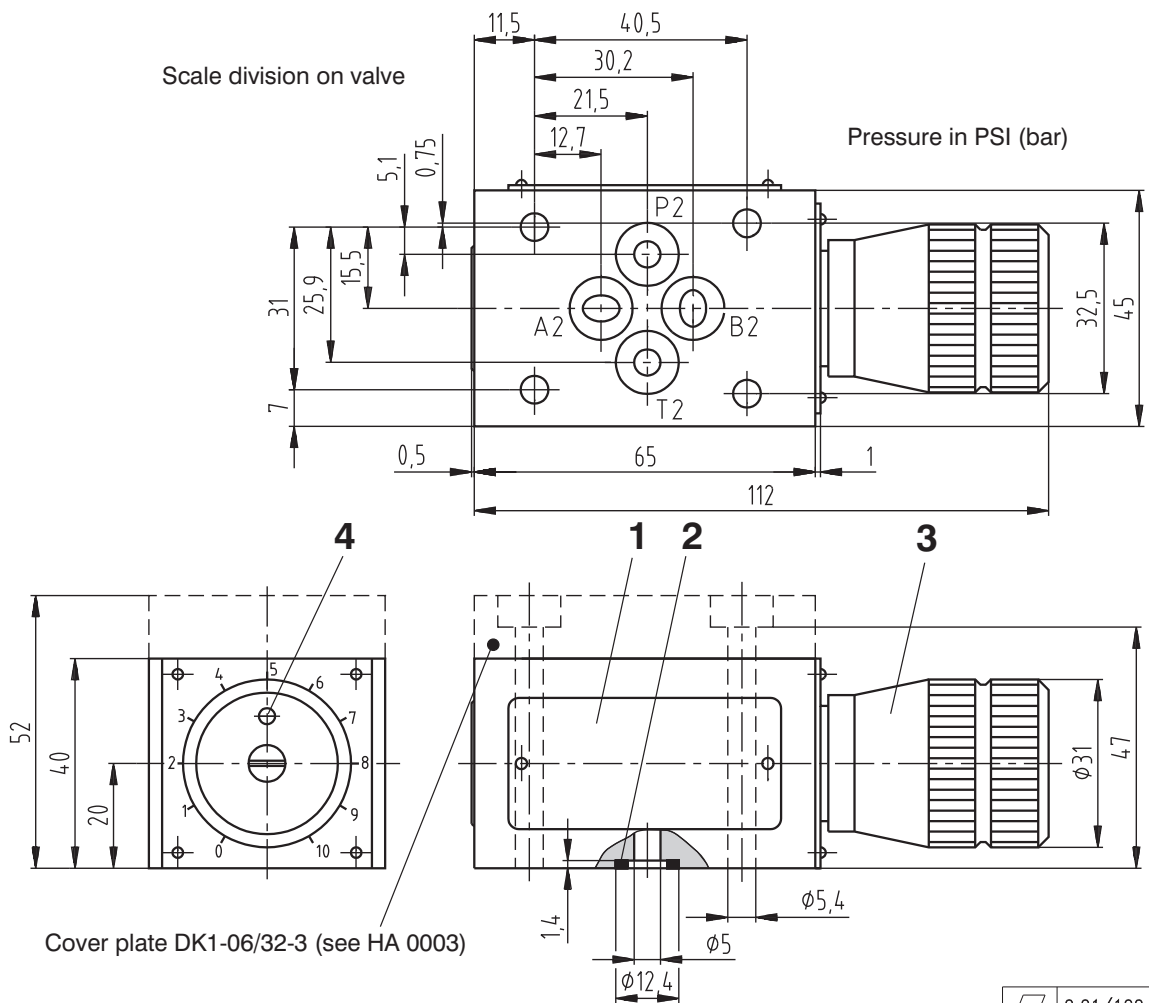

- 1 Name plate
- 2 O-ring 8 x 2 (4 pcs.), supplied with valve
- 3 Adjustment mechanism: clockwise rotation=flow decrease
counter-clockwise rotation=flow increase
- 4 Hole with set screw for fixing the handknob in set position

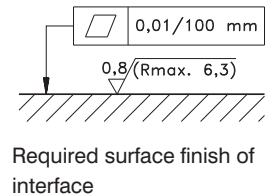

Spare Parts

Seal kit

Type	Dimensions, quantity	Ordering number
	O-ring	
Standard NBR	19,6 x 2,3 (1pc.)	20794900
	8/4 1078 NBR80 (1 pc.)	
	16 x 2 (1 pc.)	
	9,25x1,68 (4 pcs.)	
	14 x 2 (1 pc.)	
Viton	19.3 x 2.4 (1 pc.)	20794800
	3 x 2.4 (1 pc.)	
	16 x 2 (1 pc.)	
	9.25 x 1.78 (4 pcs.)	
	14 x 2 (1 pc.)	

Preferred Types of Valves

Type	Ordering Number
VSS1-306-16-11	20794000

Caution!

- The packing foil is recyclable.
- The transport plate is to be returned to the supplier.
- Mounting bolts M5x60 or assembly studs (4 pcs.) must be ordered separately. Tightening torque 8.9 Nm.
- The technical information regarding the product presented in this catalogue is for descriptive purposes only. It should not be construed in any case as a guaranteed representation of the product properties in the sense of the law.

ARGO-HYTOS s.r.o. CZ - 543 15 Vrchlabí
 Tel.: +420-499-403111, Fax: +420-499-403421
 E-mail: sales.cz@argo-hytos.com
 www.argo-hytos.com

- Cartridge design
- Flow rate setting with adjustment screw
- For use in meter-in, meter-out and bleed-off applications

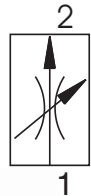

4

Functional Description

Pressure compensated flow control valves are installed in hydraulic systems where only small speed or revolution variation due to load changing are required. The valve consists of throttling orifice (1), pressure compensator (2), bushing (3), adjustment screw (4) and spring (5).

Throttling in direction 1 → 2 is realised on the throttling orifice. The flow rate depends on the orifice diameter and on the pressure difference at the orifice. The pressure difference can be adjusted in a certain range through preloading the spring (5), which results in the respective flow change. The allocation of the orifice diameters and the corresponding flow rates is apparent from the characteristics. The flow rate adjustment can be accomplished by adjustment screw (4). The clockwise rotation increases the flow rate, the anticlockwise rotation decreases the flow rate.

The flow rate stabilization is provided by pressure compensator (2), which is situated behind the throttling orifice and mounted into bushing (3). The pressure compensator continuously compares the pressure difference at the throttling orifice (1) with the value given by the spring preload.

In flow direction 2 → 1, the valve works as an ordinary throttle valve without pressure compensation feature. The pressure losses depend on the orifice diameter – see the respective characteristics.

The valve housing (7), the nut (6) and the adjustment screw (4) are zinc coated.

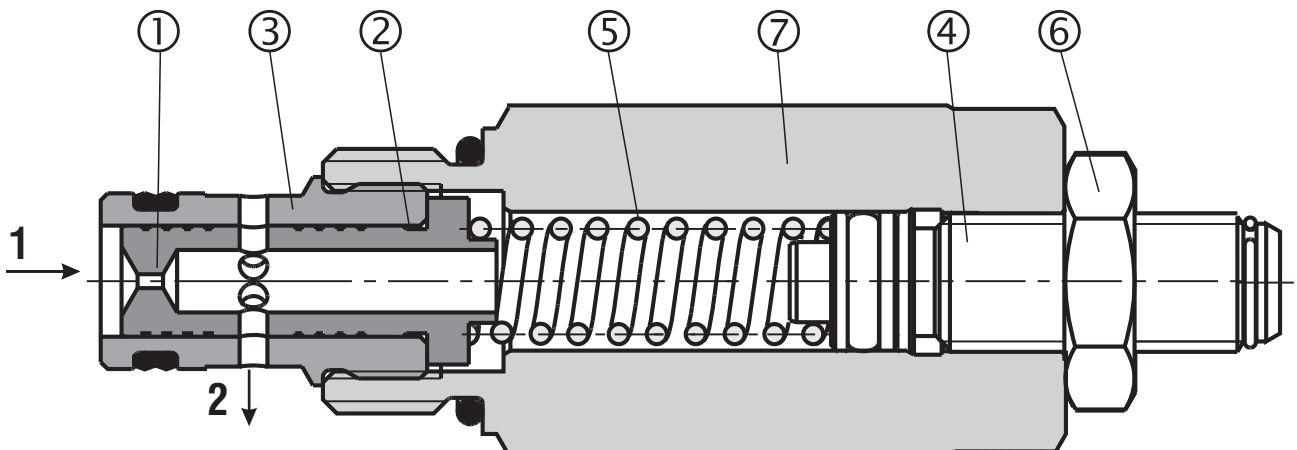

Ordering Code

SF22A-A2 /

2 Way Cartridge Flow Control Valve
3/4-16UNF

High performance

H

no designation
V

Seals
Standard (NBR)
Viton (FPM)

2
6
12

Nominal flow rates
Flow 2 L/min (0.53 GPM)
Flow 6 L/min (1.59 GPM)
Flow 12 L/min (3.17 GPM)

4

Technical Data

Valve size	A2		
Cartridge cavity	3/4-16 UNF-2A		
Nominal flow rates	L/min (GPM)	2 (0.53)	6 (1.59) 12 (3.17)
Flow range	see Q-Δp characteristic		
Maximum working pressure	bar (PSI)	350 (5076)	
Hydraulic fluid	Hydraulic oils of power classes (HL, HLP) to DIN 51524		
Fluid temperature range (NBR)	°C (°F)	-30... + 100 (-22 ... +212)	
Fluid temperature range (Viton)	°C (°F)	-20 ... +120 (-4 ... +248)	
Viscosity range	mm ² /s (SUS)	10 ... 500 (49 ... 2450)	
Maximum degree of fluid contamination	Class 21/18/15 to ISO 4406		
Weight	kg (lbs)	0,186 (0.410)	
Mounting position	unrestricted		
Valve body (data sheet HA 0018)	SB-A2		

Δp-Q Characteristics

Measured at v = 32 mm²/s (156 SUS)

Flow directional 2 → 1 (Throttling without compensator)

Nominal flow rates 2, 6, 12

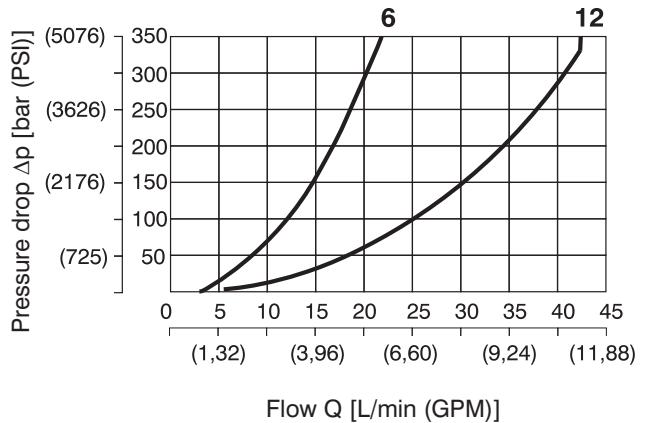
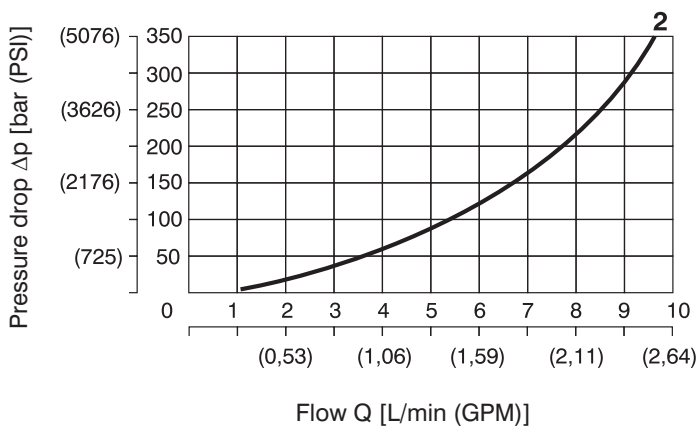

Δp-Q Characteristics

Measured at $v = 32 \text{ mm}^2/\text{s}$ (156 SUS)

Flow direction 1 → 2 (Controlled flow)

Nominal flow rate 2 L/min (0.53GPM)

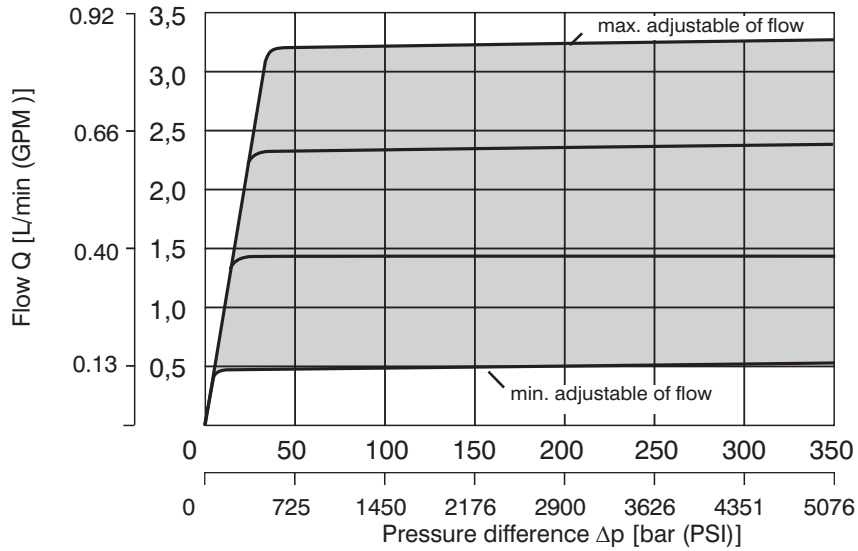

Nominal flow rate 6 L/min (1.59 GPM)

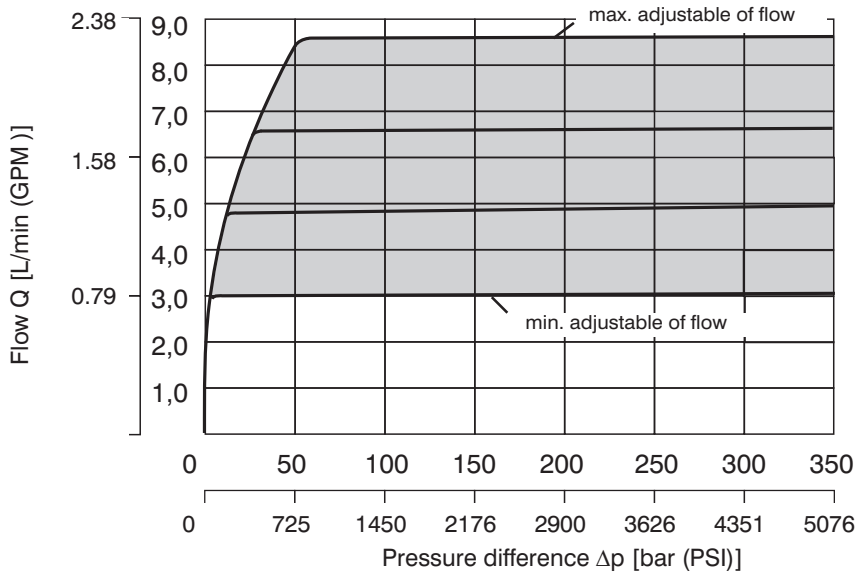

Nominal flow rate 12 L/min (3.17 GPM)

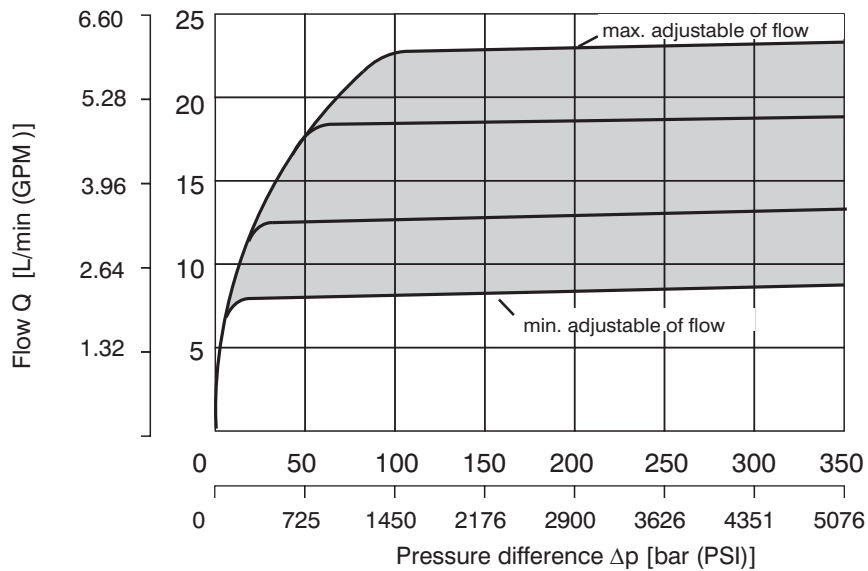

4

Valve Dimensions

Dimensions in millimeters and inches

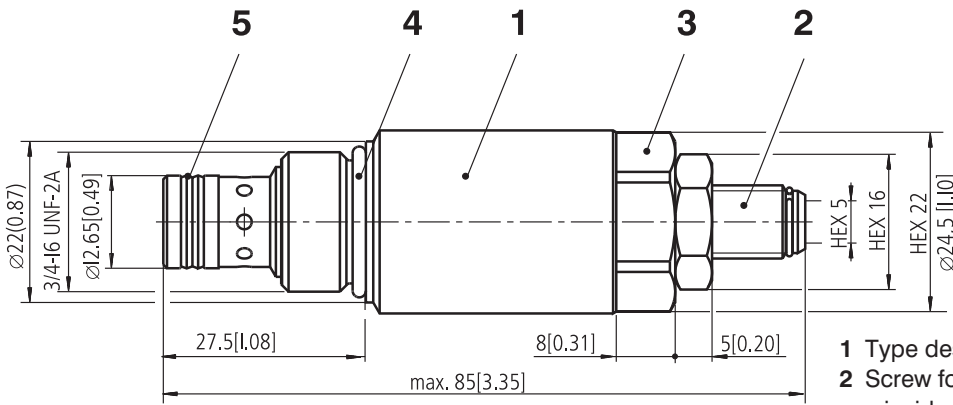

- 1 Type designation (stamped)
- 2 Screw for fine flow adjustment
 - inside hexagon 5 mm (0.20 inch)
 - anticlockwise rotation = flow decrease
 - clockwise rotation = flow increase
- 3 Wrench flats size 22 mm (0.87 inch), tightening torque 30 Nm (22.1 lbs)
- 4 Sealing: O-ring 17 x 1,8 supplied with valve
- 5 Sealing: Dualseal 10,3 x 12,7 x 3,1 supplied with valve

4

Cavity

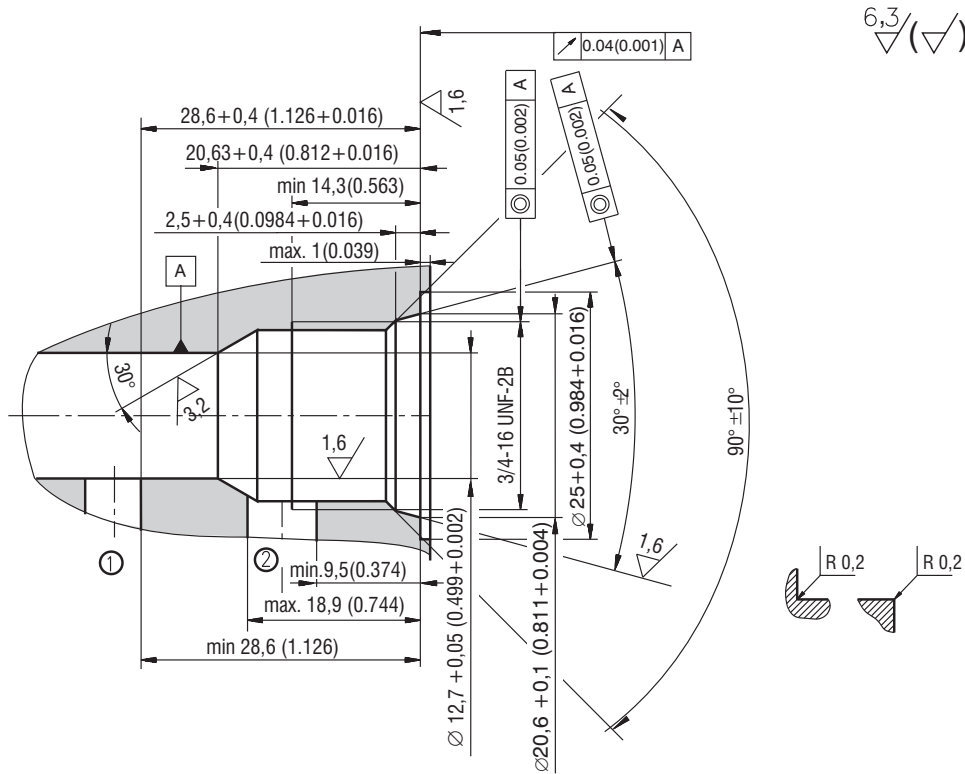

Spare Parts

Dimensions in millimeters

Seal kit

Type	Dimensions, quantity		Ordering number
	O-ring	Dualseal - PU	
Standard - NBR		10,3 x 12,7 x 3,1 (1 pc.)	20157700
Viton	17 x 1,8 (1pc.)		15606500

Caution!

- The plastic packaging is recyclable.
- Certified documentation is available per request.

ARGO-HYTOS s.r.o. CZ - 543 15 Vrchlaví
 Tel.: +420-499-403 111,
 E-mail: info.cz@argo-hytos.com
 www.argo-hytos.com

- Hardened and precision working parts
- Flow rate setting with adjustment screw or with hand wheel
- Quiet and stable flow setting over complete pressure range
- Fine low-torque adjustment

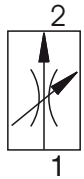

4

Functional Description

Pressure compensated flow control valves are installed in hydraulic systems where only small speed or revolution variation due to load changing are required.

The valve consists basically of throttling orifice (1), pressure compensator (2), bushing (3), adjustment screw (4) and spring (5).

Throttling in direction 1 → 2 is realised on the throttling orifice. The flow rate depends on the orifice diameter and on the pressure difference at the orifice. The pressure difference can be adjusted in a certain range through preloading the spring (5), which results in the respective flow change. The allocation of the orifice diameters and the corresponding flow rates is apparent from the characteristics. The flow rate adjustment can be accomplished by adjustment screw (4). The clockwise rotation increases the flow rate, the anticlockwise rotation decreases the flow rate.

The flow rate stabilization is provided by pressure compensator (2), which is situated behind the throttling orifice and mounted into bushing (3). The pressure compensator continuously compares the pressure difference at the throttling orifice (1) with the value given by the spring preload.

The valve cannot be fully closed for flow 0 L/min. In flow direction 2 → 1, the valve works as an ordinary throttle valve without pressure compensation feature. The pressure losses depend on the orifice diameter – see the respective characteristics.

The valve housing (7), the nut (6) and the adjustment screw (4) are zinc coated.

Model S

Model R

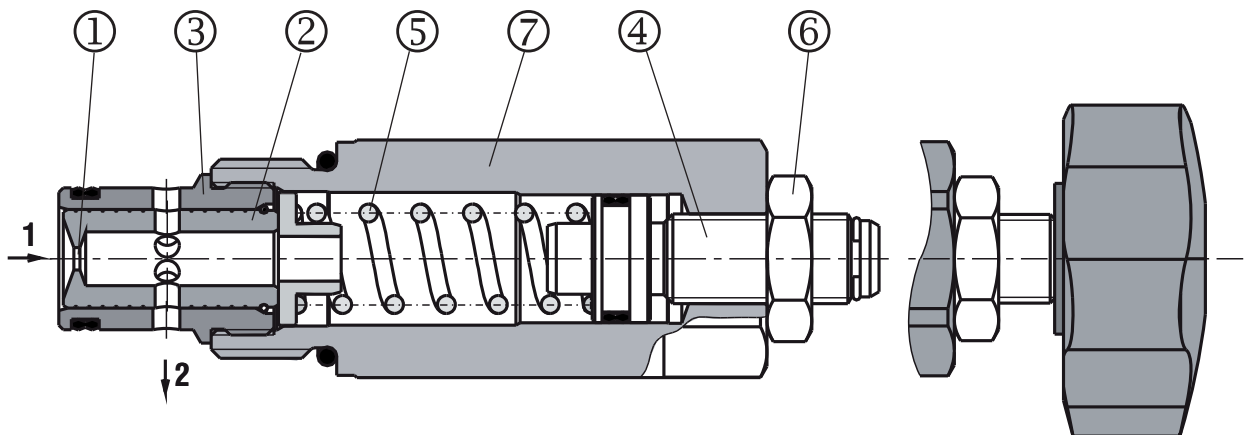

Ordering Code

SF22A-B2 /

2 way Flow Control Valve
pressure compensated
7/8-14 UNF

High performance

H

no designation
V

S
R

Seals
NBR
FPM (Viton)

Adjustment option
Inside hexagon 5 mm
Adjustable handknob

12
20
40

Flow rate
Flow 3,2-12 L/min (0.13-0.47 GPM)
Flow 5,1-20 L/min (0.20-0.79 GPM)
Flow 5,0-41 L/min (0.19-1.61 GPM)

Technical Data

Valve size	B2		
Cartridge thread	7/8-14 UNF-2A		
Nominal Flow rate	12	20	40
Flow range	see Q-Δp characteristic		
Maximum working pressure	bar (PSI) 350 (5076)		
Hydraulic fluid	Hydraulic oils of power classes (HL, HLP) to DIN 51524		
Fluid temperature range (NBR)	°C (°F) -30... + 100 (-22 ... +212)		
Fluid temperature range (Viton)	°C (°F) -20 ... +120 (-4 ... +248)		
Viscosity range	mm ² /s (SUS) 10 ... 500 (49 ... 2450)		
Maximum degree of fluid contamination	Class 21/18/15 to ISO 4406		
Weight	kg (lbs) 0,220 (0.485)		
Mounting position	unrestricted		
Valve body (data sheet HA0018)	SB-B2		

Δp-Q Characteristics

Measured at $v = 32 \text{ mm}^2/\text{s}$ (156 SUS)

Flow directional 2→1 (Throttling without compensator)

Flow rate 12, 20, 40

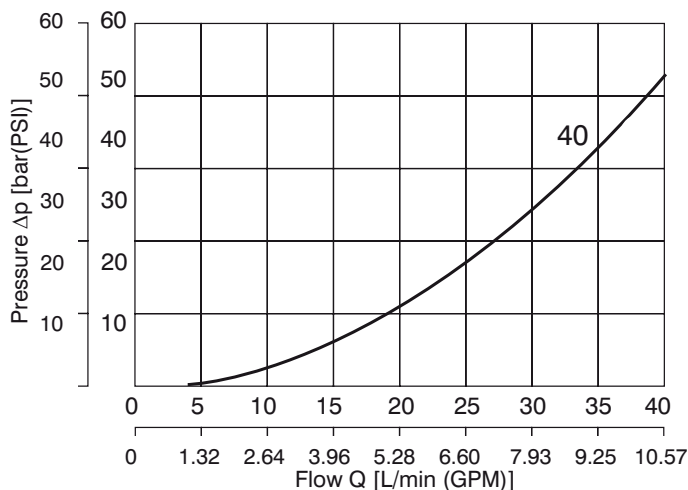
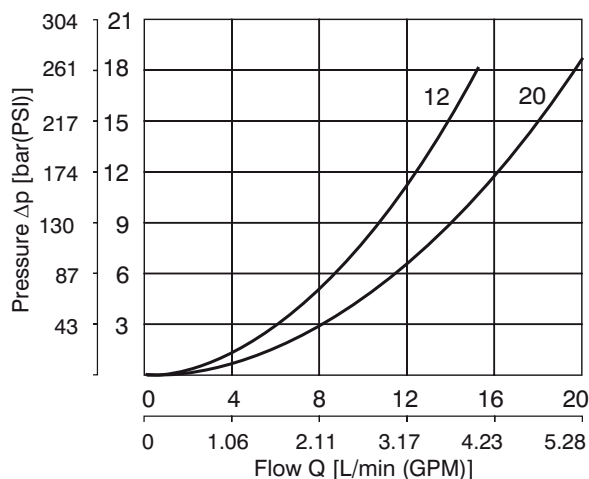

Δp -Q Characteristics

Measured at $v = 32 \text{ mm}^2/\text{s}$ (156 SUS)

Flow directional 1 → 2 (Controlled flow)

Flow rate 12

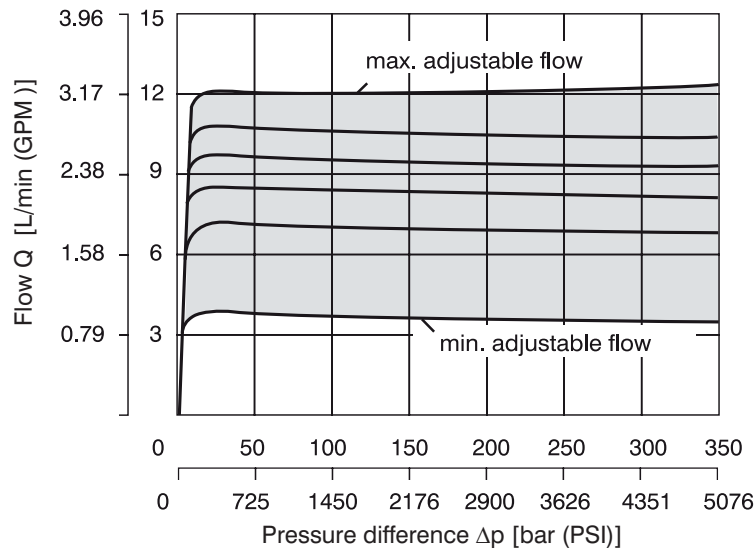

Flow rate 20

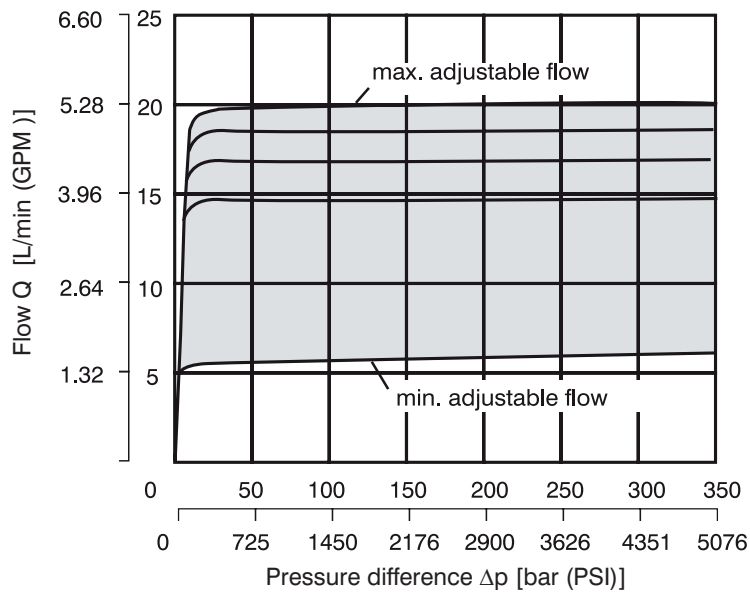

Flow rate 40

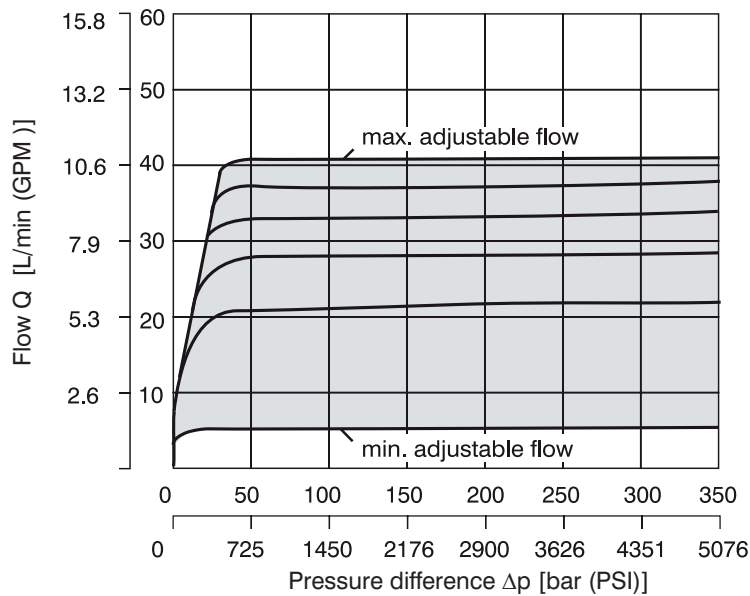

4

Valve Dimensions

Dimensions in millimeters (inches)

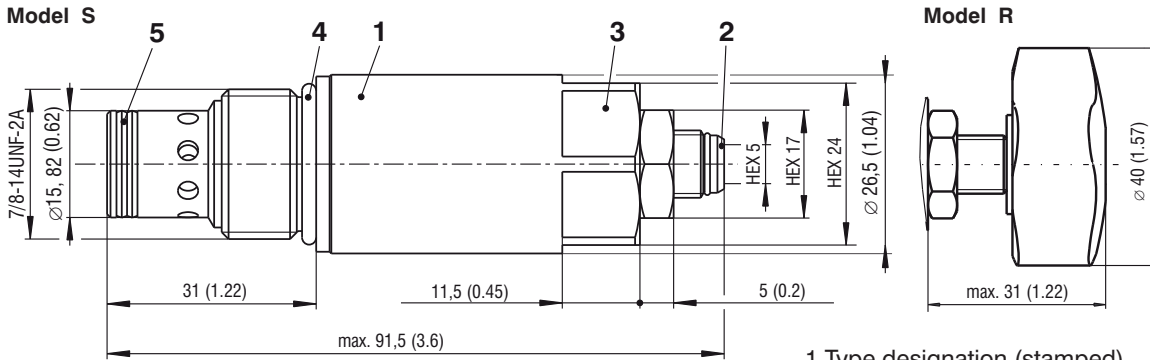

- 1 Type designation (stamped)
- 2 Screw for fine flow adjustment
 - inside hexagon 5 mm
 - anticlockwise rotation = flow decrease
 - clockwise rotation = flow increase
- 3 Spanner size 24 mm
tightening torque 60+5 Nm (44.3+3.7 lbf.ft)
- 4 Sealing: O-ring 19,4x2,1 (supplied with valve)
- 5 Sealing: Dualseal 13,47 x 15,87 x 3,1 (supplied with valve)

Cavity

Dimensions in millimeters (inches)

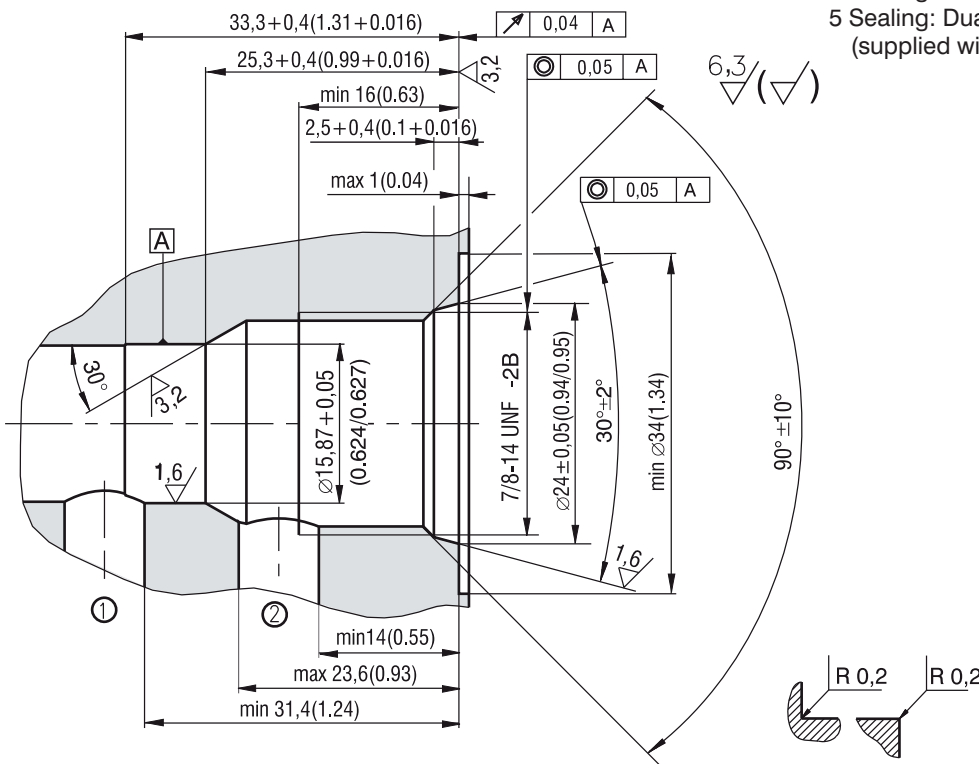

Spare Parts

Type	Dimensions, quantity		Ordering number
NBR	O-ring	Dualseal - PU	
	19,4 x 2,1 (1pc)	13,47 x 15,87 x 3,1 (1pc)	20159100
FPM (Viton)	19,4 x 2,1 (1pc)	13,47 x 15,87 x 3,1 (1pc)	20159100
	19,4 x 2,1 (1pc)		20144100

Caution!

- The plastic packaging is recyclable. .
- Certified documentation is available per request.

ARGO-HYTOS s.r.o. CZ - 543 15 Vrchlábí
 tel.: +420-499-403 111
 e-mail: info.cz@argo-hytos.com
 www.argo-hytos.com

- Volumetric flow control independent to the load
- Volumetric flow control independent to the viscosity
- Large flow range

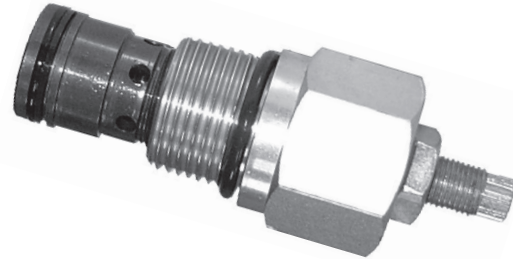
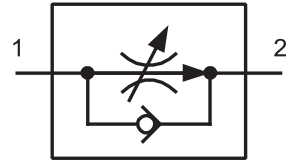

4

Functional Description

The valve consists of an adjustable measuring orifice plate after which it is installed a stabilizer of pressure drop and of an by-pass unidirectional valve formed by a bushing of the stabilizer gate valve fitted with a seat on the front surface.

During the flow from (1) to (2) the liquid flows through the centre of the stabilizer gate valve and applies pressure at the same time to the gate valve of the unidirectional valve to press it in the seat and then continues to flow through the throttling cross section to the side channel (2). The stabilizer has been designed to serve for maintaining a pressure difference arisen in front of the measuring orifice plate and after the measuring orifice plate at a constant level of approximately of 1.2 MPa given by the spring force so as to ensure a constant

rate of flow through the channel (2). The pressure in front of the throttling orifice plate acts to the side part of the stabilizer gate valve and the pressure in the channel (2) acts to back side of the stabilizer gate valve. Due to permanent equalizing the forces the position of the stabilizer gate valve changes with each change of pressure before and after the measuring orifice plate and in this way it results in appropriate decreasing or eventually appropriate increasing the flow cross section in the channel (2).

In the direction from (2) to (1) the liquid flows through the unidirectional valve with a small pressure drop.

As for appropriate basic surface finish the external parts are zinc coated.

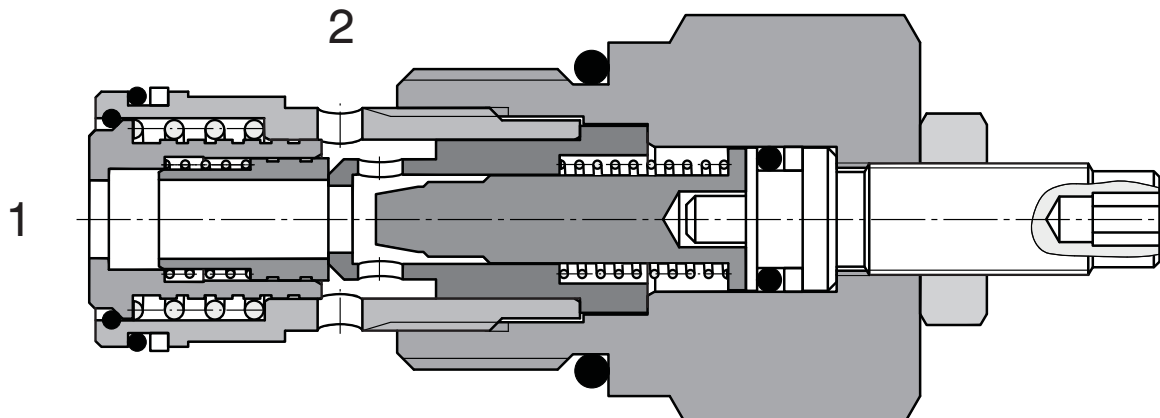

Ordering Code

SF2C2A-K2/I

2 way flow control valve
with free flow check valve

Adjustable flow range

4 - 40 L/min

6 - 60 L/min

4

6

no designation

Seals
NBR

Technical Data

Cavity		M27 x 2
Adjustment range	L/min	4 - 60
Max. pressure	bar	350
Hydraulic fluid		Hydraulic oil (HM, HV) according to DIN 51524
Fluid temperature range	°C	-20 ... +90
Viscosity	mm ² /s	20 ... 400
Maximum degree of fluid contamination		According to ISO 4406, Class 21/18/15
Weight	kg	0.29
Maximum valve tightening torque in valve body or in control block	Nm	75 ⁺²
Mounting position		Unrestricted

p-Q Characteristics

Measured at $\nu = 40 \text{ mm}^2/\text{s}$

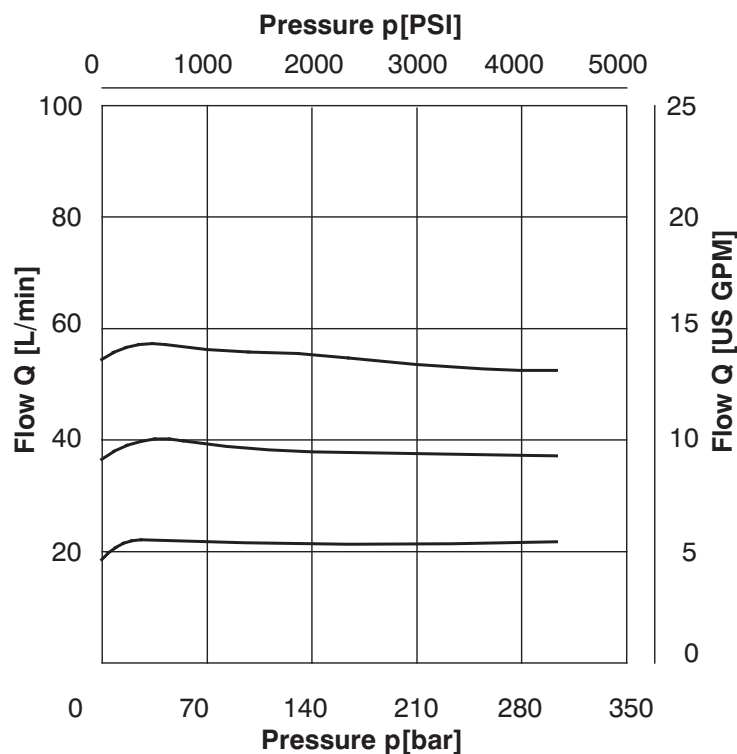

Dimensions

Measurements in millimeters

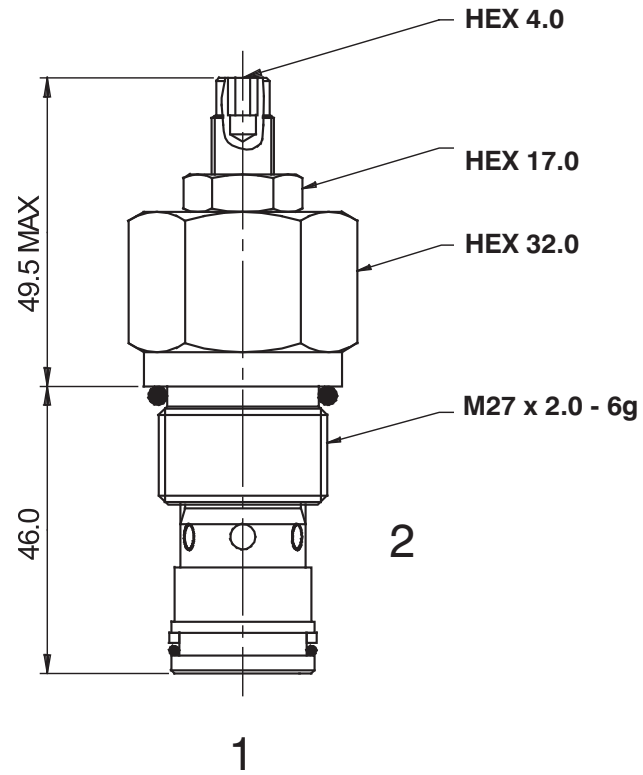

4

Cavity

Measurements in millimeters

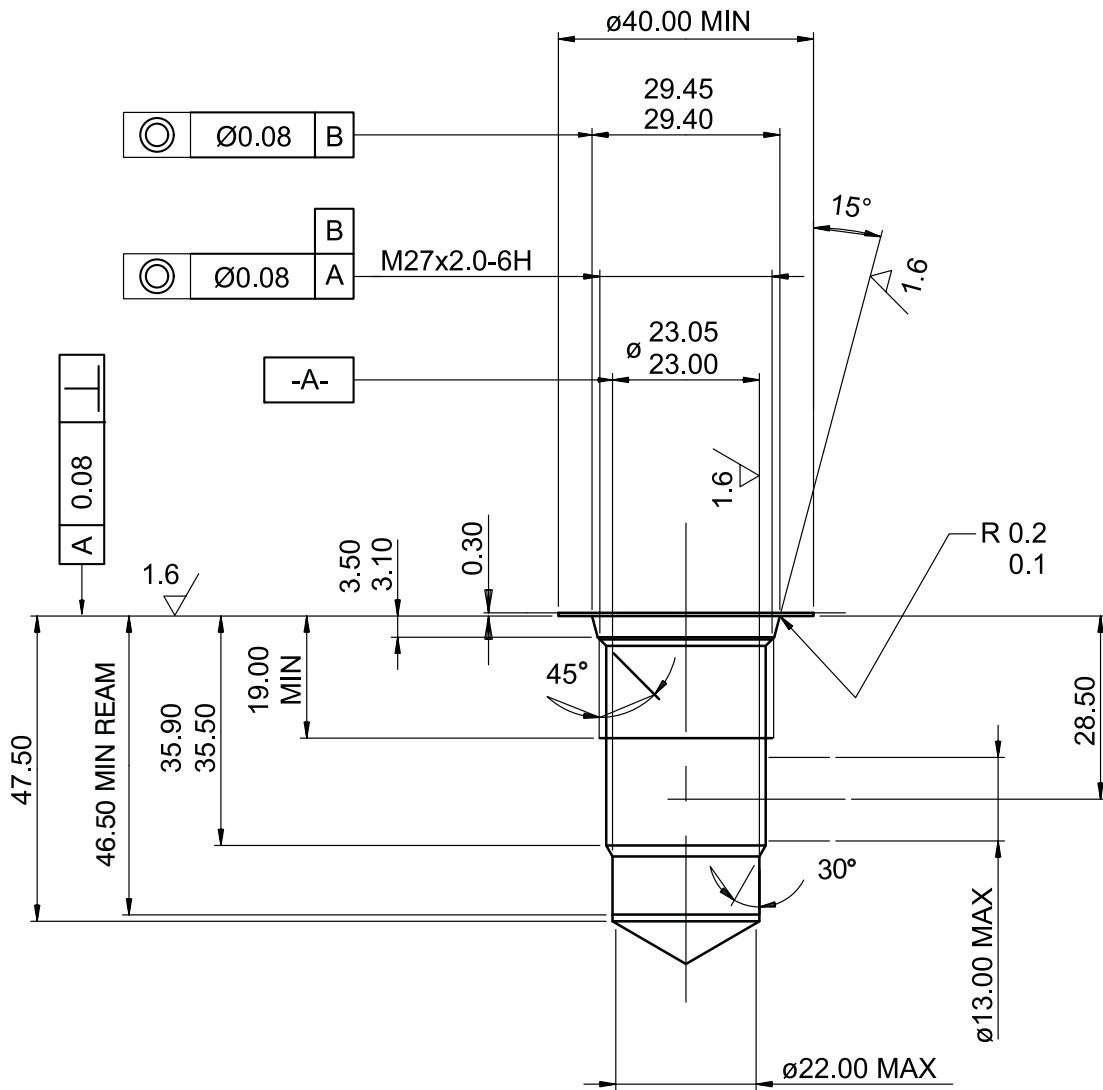

Valve Bodies

Measurements in millimeters

ISO A

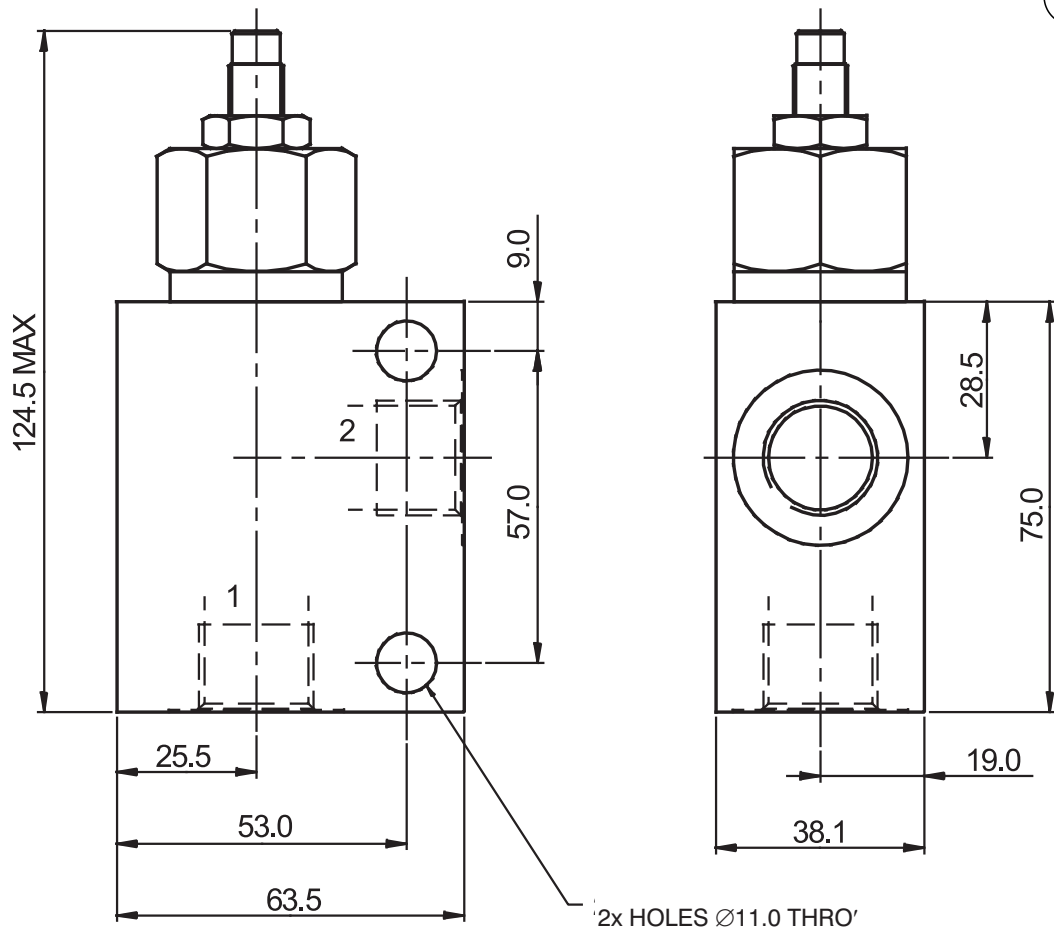
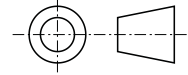

Body without valve			
Material	Ports	Port size	Type code
Aluminium	1, 2	G1/2	SB-K2-0105AL
	1, 2	SAE 10, 7/8-14	SB-K2-0106AL
Steel	1, 2	G1/2	SB-K2-0105ST
	1, 2	SAE 10, 7/8-14	SB-K2-0106ST

The use of aluminium bodies is limited to a maximum operating pressure of 210 bar.

Spare Parts

Seal kits on request.

Caution!

- The packing foil is recyclable.
- The technical information regarding the product presented in this catalogue is for descriptive purposes only. It should not be construed in any case as a guaranteed representation of the product properties in the sense of the law.

ARGO-HYTOS s.r.o. CZ - 543 15 Vrchlabí
 Tel.: +420-499-403111, Fax: +420-499-403421
 E-mail: sales.cz@argo-hytos.com
 www.argo-hytos.com

- Priority style
- Constant flow largely independent to load and viscosity
- Port 2 can be pressurized
- Various flow ranges available

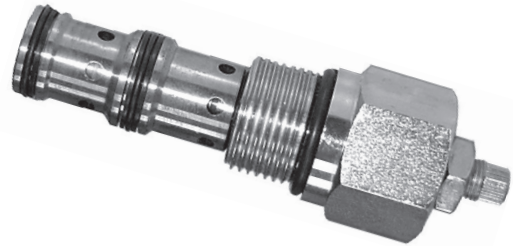
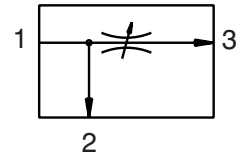

4

Functional Description

The valve consists of an adjustable measuring orifice plate after which it is installed a stabilizer of pressure drop. During the flow from (1) to (3) the liquid flows through the centre of the stabilizer slide valve and then through radial orifices to the side channel (3). The stabilizer has been designed to serve for maintaining a pressure difference arisen on the measuring orifice plate at a constant level of approximately of 12 bar given by the spring force so as to ensure a constant rate of flow through the channel (3). The excessive flow of the liquid cause a dynamic pressure in channel (1) by means of which the slide valve of the stabilizer is shifted against the spring and opens the flow cross section to the channel (2) through which the excessive liquid flows out either to the drain or to another consumer. The channel (2) can be loaded by

pressure. Due to permanent equalizing the forces the position of the stabilizer gate valve changes with each change of pressure before and after the measuring orifice plate and in this way it results in appropriate decreasing or eventually appropriate increasing the flow cross section of channels.

The liquid can flow through the valve also in opposite direction from (3) to (1), however, in a limited extent taking into consideration the fact that the liquid shall flow through the throttling cross section.

As for appropriate basic surface finish the external parts are zinc coated.

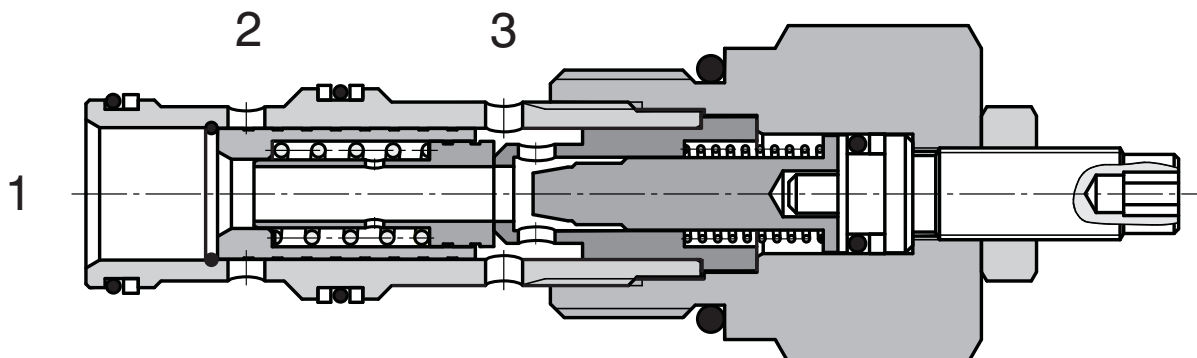

Ordering Code

SF32A-K3/I

3 Way Flow Control Valve

no designation

Seals
NBR

Adjustable flow range

4 - 40 L/min

4

6 - 60 L/min

6

Technical Data

Cavity		M27 x 2
Adjustment range	L/min	4 - 60
Max. pressure	bar	350
Hydraulic fluid		Hydraulic oil (HM, HV) according to DIN 51524
Fluid temperature range	°C	-20 ... +90
Viscosity	mm ² /s	20 ... 400
Maximum degree of fluid contamination		According to ISO 4406, Class 21/18/15
Weight	kg	0.16
Maximum valve tightening torque in valve body or in control block	Nm	75 ⁺²
Mounting position		Unrestricted

p-Q Characteristics

Measured at $v = 40 \text{ mm}^2/\text{s}$

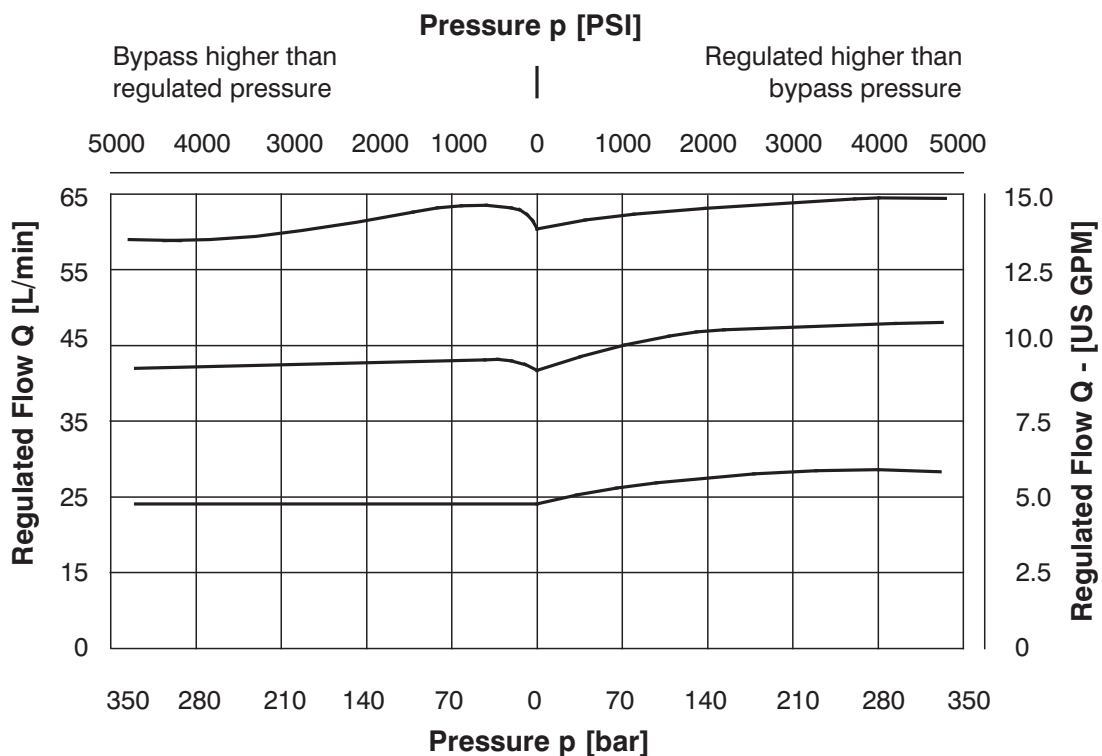

Dimensions

Measurements in millimeters

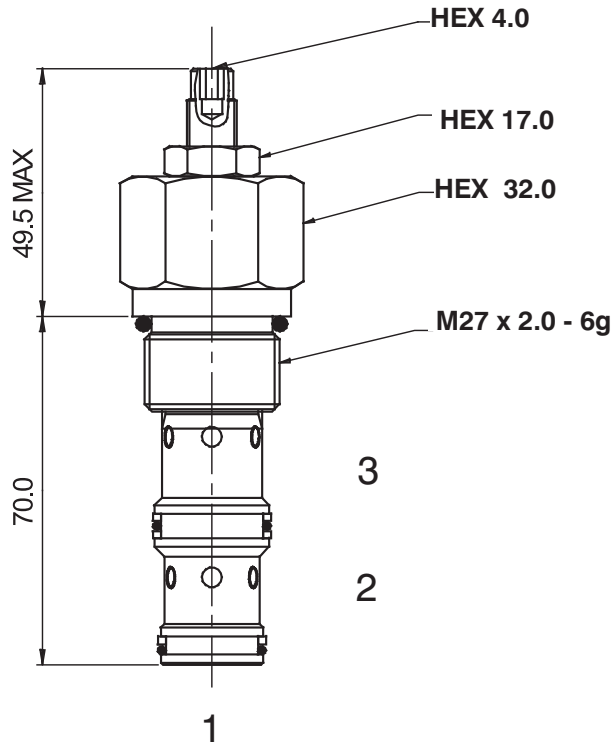

4

Cavity

Measurements in millimeters

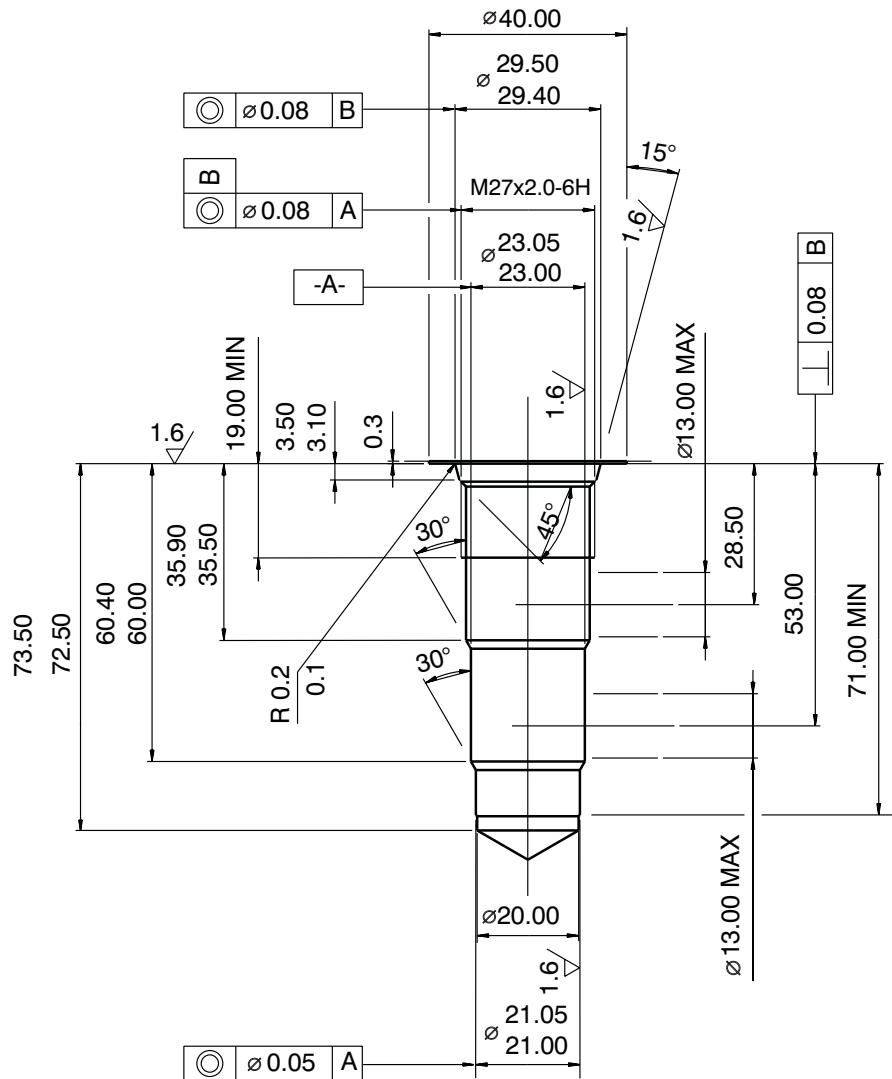

Valve Bodies

Measurements in millimeters

ISO A

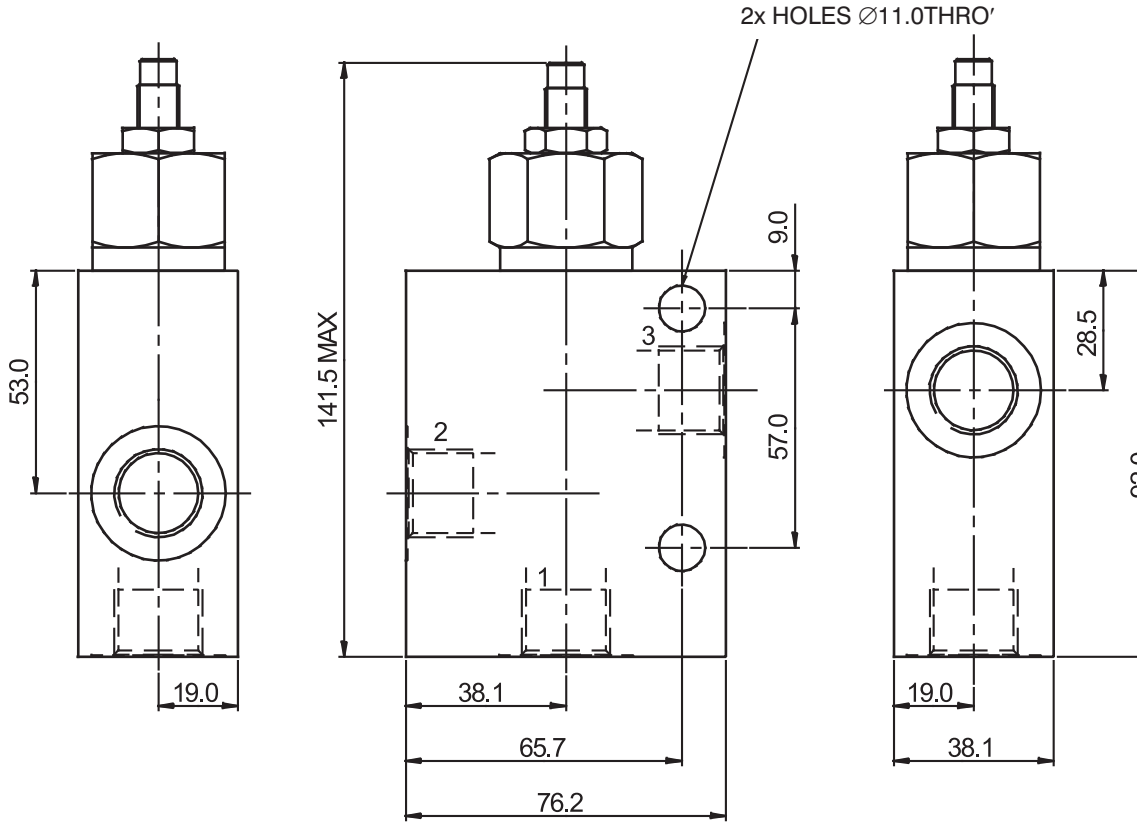
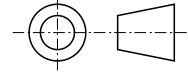

Body without valve			
Material	Ports	Port size	Type code
Aluminium	1, 2, 3	G1/2	SB-K3-0105AL
	1, 2, 3	SAE 10, 7/8-14	SB-K3-0106AL
Steel	1, 2, 3	G1/2	SB-K3-0105ST
	1, 2, 3	SAE 10, 7/8-14	SB-K3-0106ST

The use of aluminium bodies is limited to a maximum operating pressure of 210 bar.

Spare Parts

Seal kits on request.

Caution!

- The packing foil is recyclable.
- The technical information regarding the product presented in this catalogue is for descriptive purposes only. It should not be construed in any case as a guaranteed representation of the product properties in the sense of the law.

ARGO-HYTOS s.r.o. CZ - 543 15 Vrchlaví
 Tel.: +420-499-403111, Fax: +420-499-403421
 E-mail: sales.cz@argo-hytos.com
 www.argo-hytos.com

- Divert flows largely independent to the load
- Combine flows largely independent to the load
- May be used for synchronisation controls
- May be used as differential lock

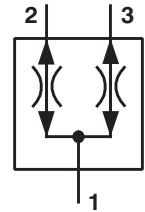

Functional Description

The valve consists of a valve body, two regulating slide valves mutually connected with a defined stroke and with a fixed measuring orifice plate and three centring springs.

The liquid flows from the channel (1) through the measuring orifice plates to the channels (2) and (3). At the same time the regulating slide valves are pressed by the pressure difference one from the other against the outer centring springs. If the load of the channels (2) and (3) is the same the regulating slide valves are held symmetrically to both the channels. At a different load the slide valve on the side of the lower load shifted by an increased pressure drop so far against the spring located behind the slide valve as a new force balance is created caused by changed cross sections of both the regulating slide valves. By this regulating course it is ensured the ratio of division is maintained also at a different load and it is compensated in essence also at a variation of load pressures.

If the liquid cannot flow through one of the channels (2) and (3) the increased dynamic pressure in this channel causes the displacement of both the slide valves to the opposite side and it results in the fact that the other channel is closed. Then, a negligible rate of flow of the liquid only can flow through the released orifice of the nozzle enabling for example the balance of end positions of two consumers.

In the opposite direction of flow both the regulating slide valves are pressed one to the other. Also in this case different load pressures or eventually their changes by changing the position of the regulating slide valves cause a change of throttling cross sections, therefore, the combining the flows occurs also in the same ratio of division.

As for appropriate basic surface finish the external parts are zinc coated.

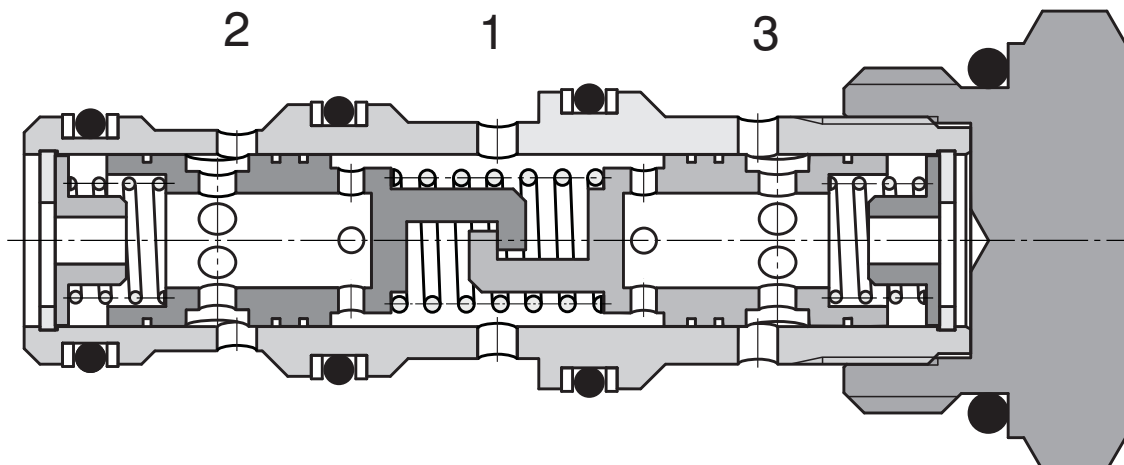

Ordering Code

SFD2F-B3/I

Flow Divider / Combiner

no designation

Seals
NBR

Capacity (input)

2 - 5 l/min	5
3,3 - 10 l/min	10
7 - 20 l/min	20
15 - 40 l/min	40

Technical Data

Cavity		7/8-14 UNF-2A
Maximum flow	L/min	40
Max. pressure	bar	350
Division ratio	%	50 - 50
Maximum variation of flow	%	± 10
Pressure drops		see Δp - Q characteristics
Hydraulic fluid		Hydraulic oil (HM, HV) according to DIN 51524
Fluid temperature range	°C	-20 ... +90
Viscosity	mm ² /s	20 ... 400
Maximum degree of fluid contamination		According to ISO 4406, Class 21/18/15
Weight	kg	0.10
Maximum valve tightening torque in valve body or in control block	Nm	34 ⁺²
Mounting position		Unrestricted

p-Q Characteristics

Measured at $v = 40 \text{ mm}^2/\text{s}$

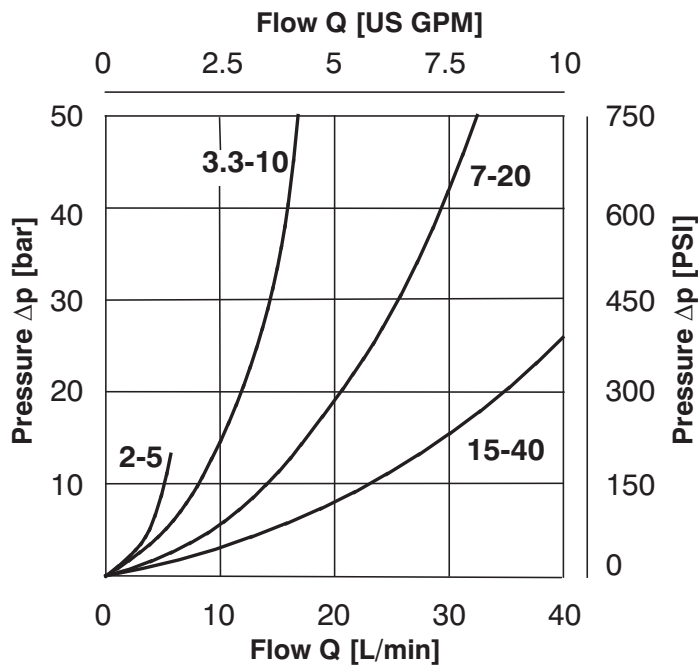

Dimensions

Measurements in millimeters

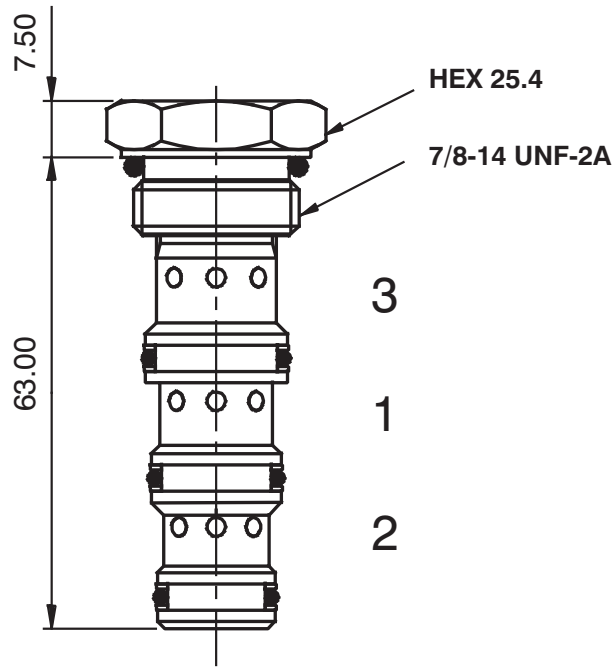

4

Cavity

Measurements in millimeters

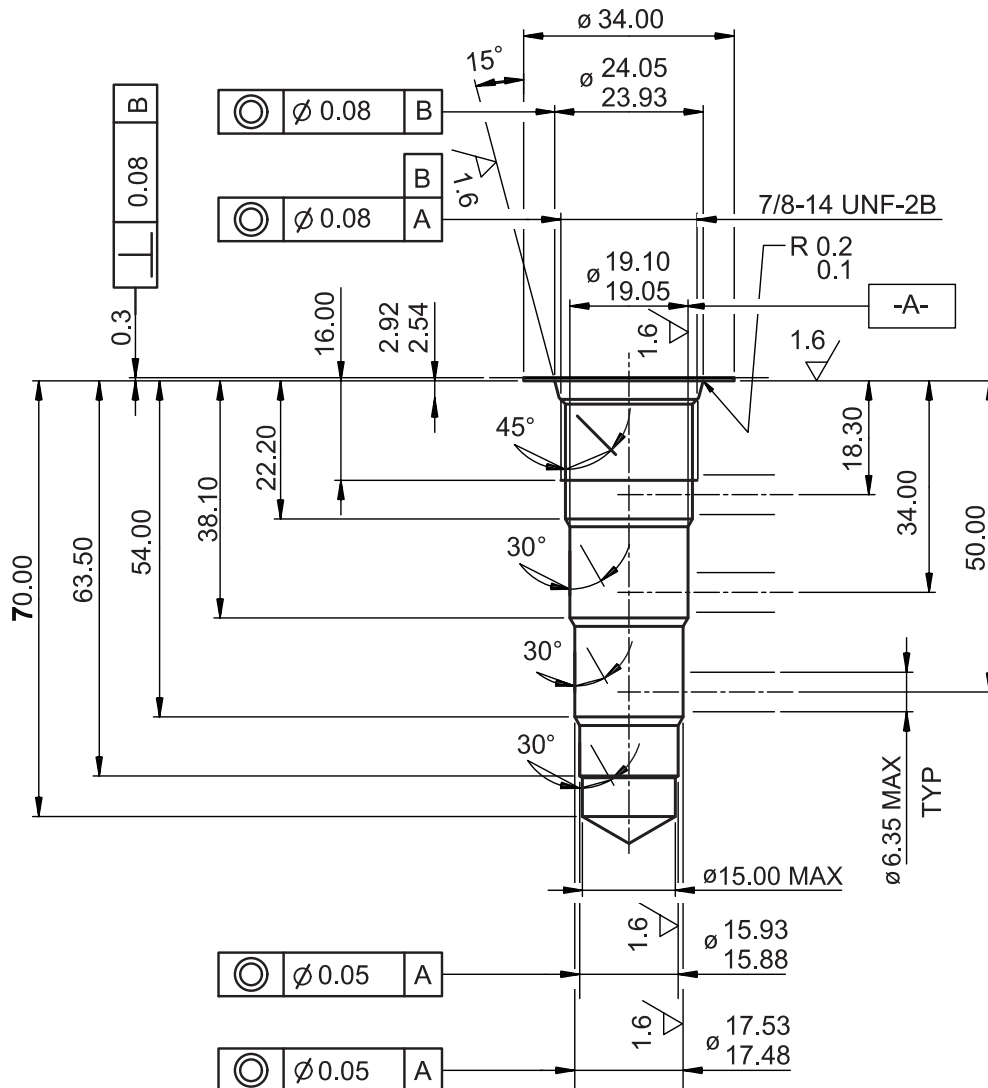

Valve Bodies

Measurements in millimeters

ISO A

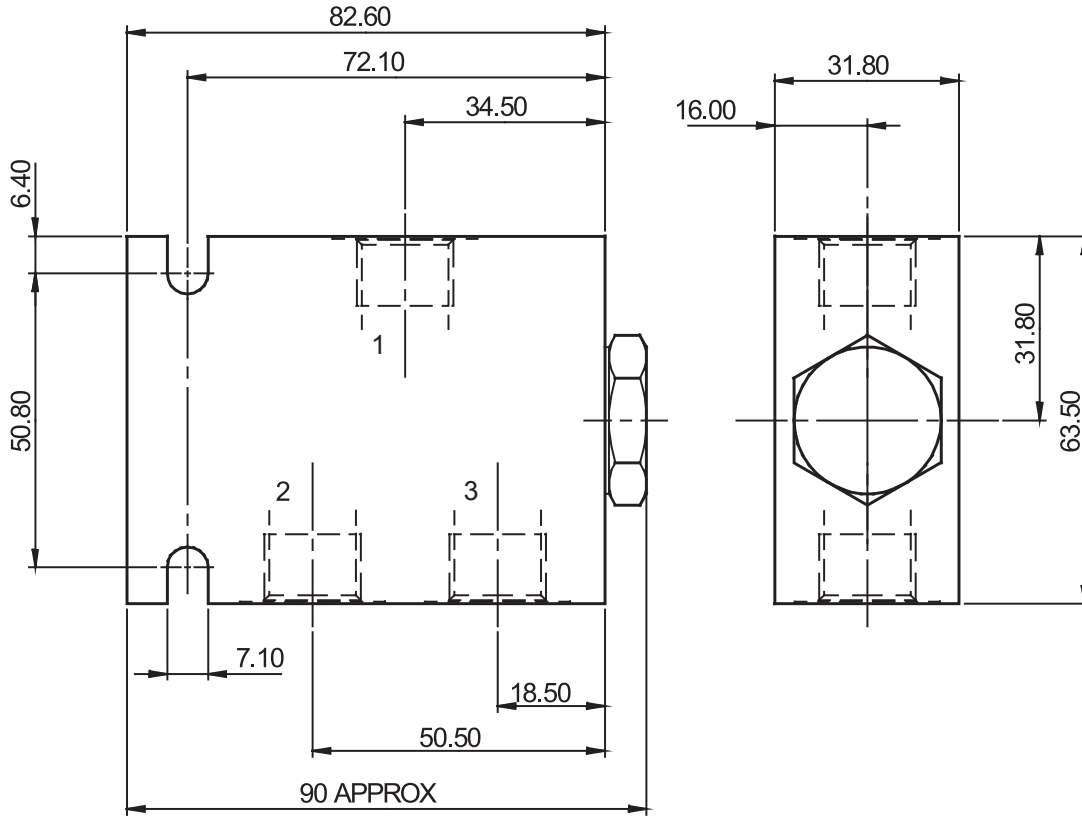
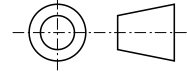

Body without valve			
Material	Ports	Port size	Type code
Aluminium	1, 2, 3	G3/8	SB-B4-0203AL
	1, 2, 3	SAE 8, 3/4-16	SB-B4-0204AL
Steel	1, 2, 3	G3/8	SB-B4-0203ST
	1, 2, 3	SAE 8, 3/4-16	SB-B4-0204ST

The use of aluminium bodies is limited to a maximum operating pressure of 210 bar.

Spare Parts

Seal kits on request.

Caution!

- The packing foil is recyclable.
- The technical information regarding the product presented in this catalogue is for descriptive purposes only. It should not be construed in any case as a guaranteed representation of the product properties in the sense of the law.

ARGO-HYTOS s.r.o. CZ - 543 15 Vrchlaví
 Tel.: +420-499-403 111
 E-mail: info.cz@argo-hytos.com
 www.argo-hytos.com

- Divert flows largely independent to the load
- Combine flows largely independent to the load
- May be used for synchronisation controls
- May be used as differential lock

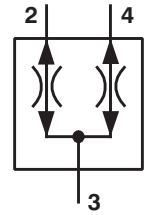

4

Functional Description

The valve consists of a valve body, two regulating slide valves mutually connected with a defined stroke and with a fixed measuring orifice plate and three centring springs.

The liquid flows from the channel (3) through the measuring orifice plates to the channels (2) and (4). At the same time the regulating slide valves are pressed by the pressure difference one from the other against the outer centring springs. If the load of the channels (2) and (4) is the same the regulating slide valves are held symmetrically to both the channels. At a different load the slide valve on the side of the lower load shifted by an increased pressure drop so far against the spring located behind the slide valve as a new force balance is created caused by changed cross sections of both the regulating slide valves. By this regulating course it is ensured the ratio of division is maintained also at a different load and it is compensated in essence also at a variation of load pressures.

If the liquid cannot flow through one of the channels (2) and (4) the increased dynamic pressure in this channel causes the displacement of both the slide valves to the opposite side and it results in the fact that the other channel is closed. Then, a negligible rate of flow of the liquid only can flow through the released orifice of the nozzle enabling for example the balance of end positions of two consumers.

In the opposite direction of flow both the regulating slide valves are pressed one to the other. Also in this case different load pressures or eventually their changes by changing the position of the regulating slide valves cause a change of throttling cross sections, therefore, the combining the flows occurs also in the same ratio of division.

As for appropriate basic surface finish the external parts are zinc coated.

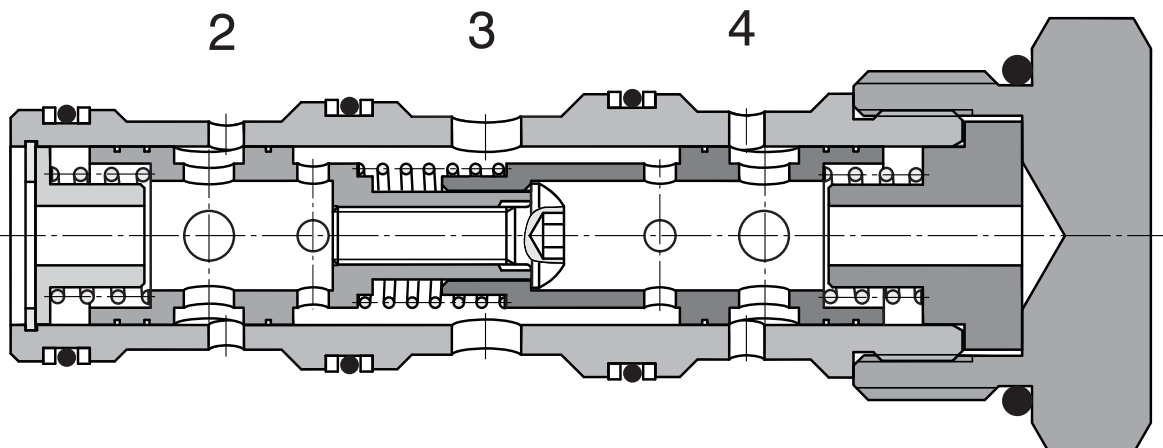

Ordering Code

SFD2F-D3/I

Flow Divider / Combiner

no designation

Seals
NBR

Capacity (input)

33 - 100 L/min

50 - 150 L/min

100

150

Technical Data

Cavity		1-5/16-12 UN-2A
Maximum flow	L/min	150
Max. pressure	bar	350
Division ratio	%	50 - 50
Maximum variation of flow	%	± 10
Pressure drops		see Δp - Q characteristics
Hydraulic fluid		Hydraulic oil (HM, HV) according to DIN 51524
Fluid temperature range	°C	-20 ... +90
Viscosity	mm ² /s	20 ... 400
Maximum degree of fluid contamination		According to ISO 4406, Class 21/18/15
Weight	kg	0.36
Maximum valve tightening torque in valve body or in control block	Nm	70 ⁺²
Mounting position		Unrestricted

p-Q Characteristics

Measured at $v = 40 \text{ mm}^2/\text{s}$

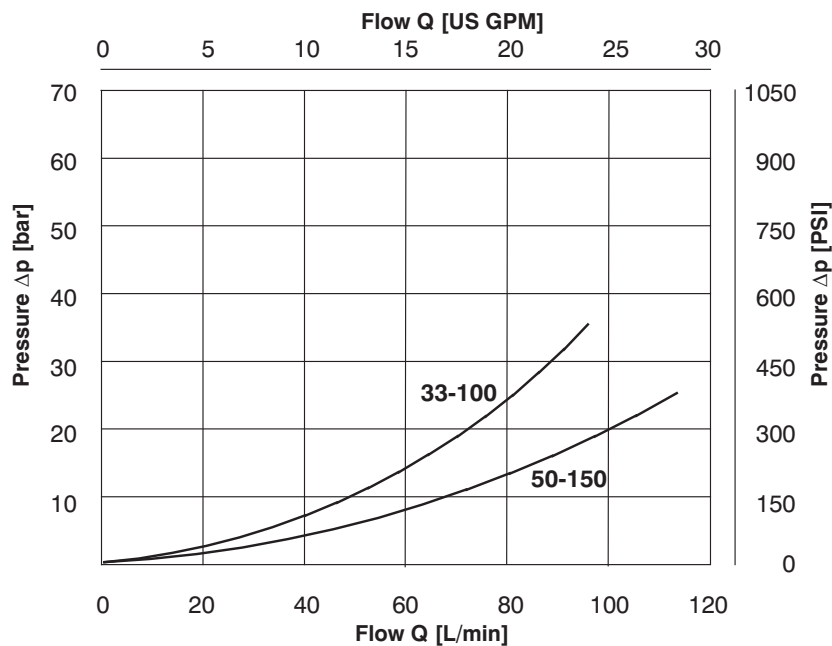

Dimensions

Measurements in millimeters

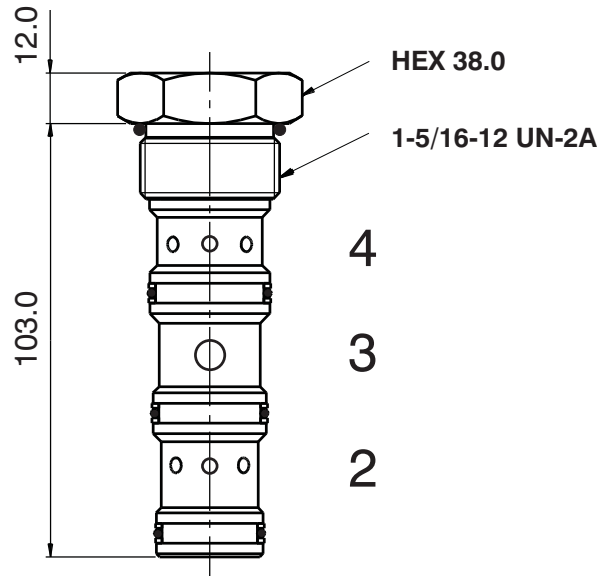

Cavity

Measurements in millimeters

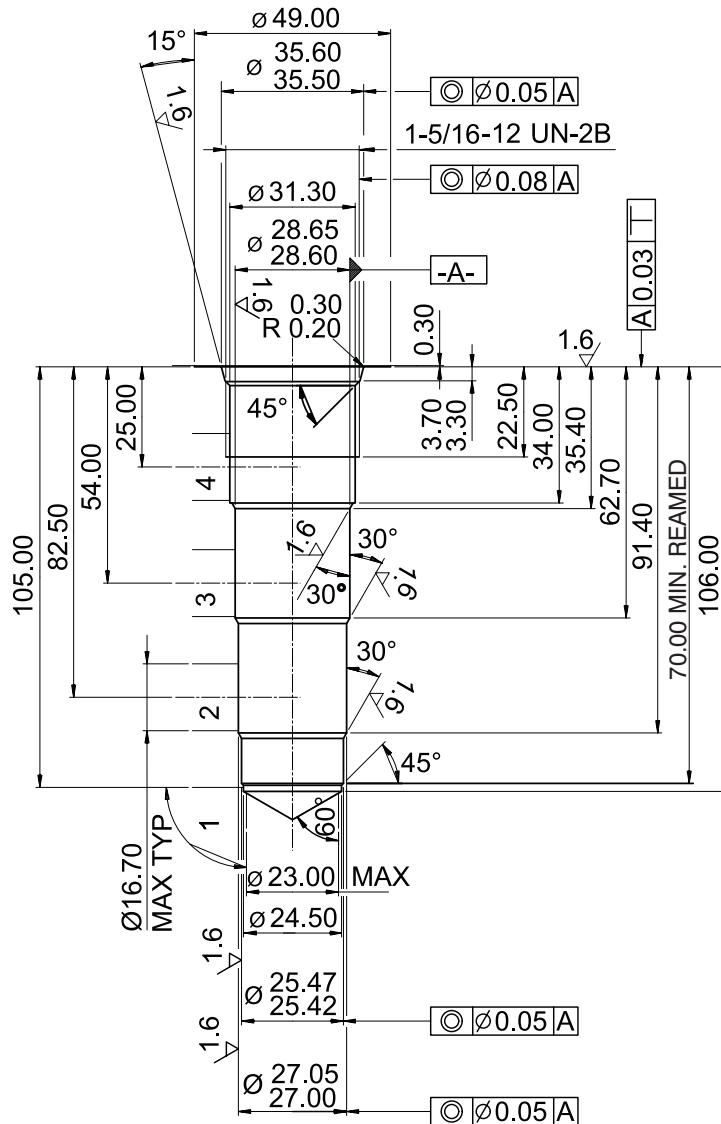

Valve Bodies

Measurements in millimeters

ISO A

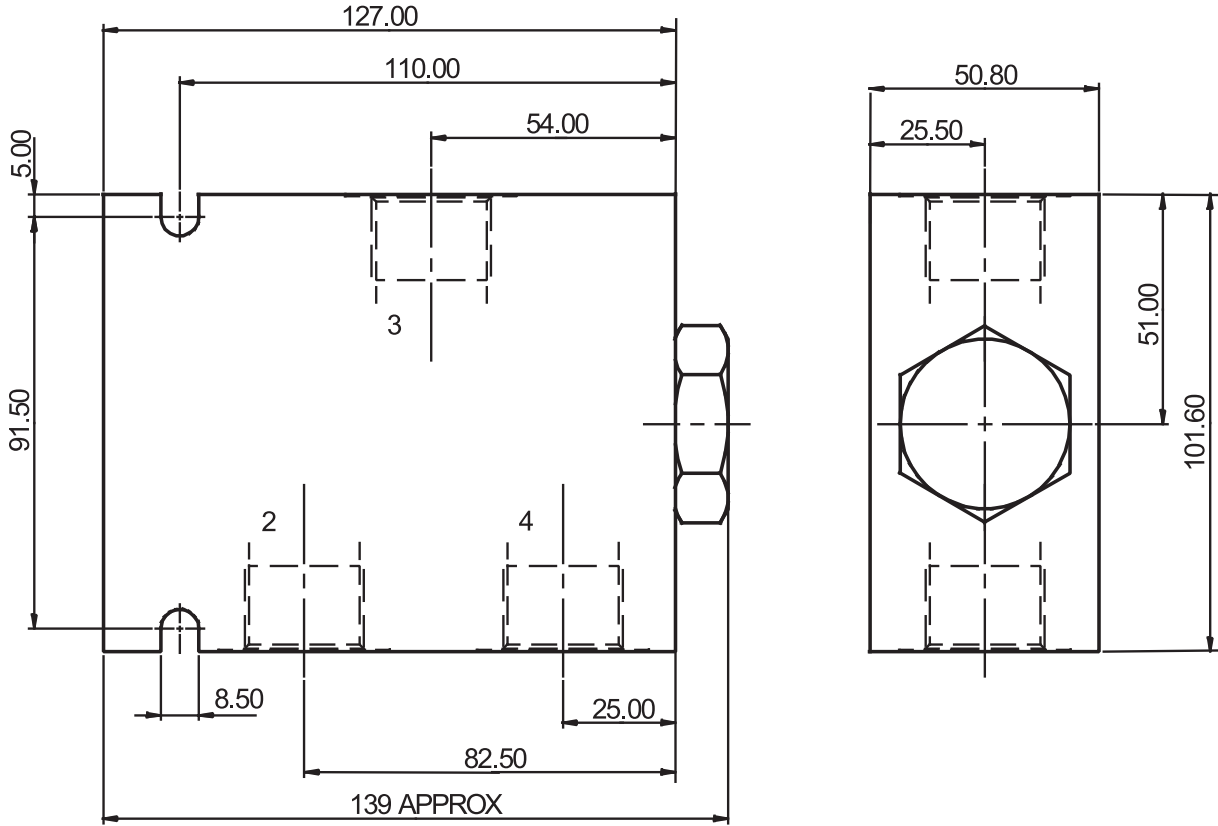
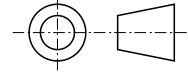

Body without valve			
Material	Ports	Port size	Type code
Aluminium	2, 3, 4	G1/2	SB-D3-0105AL
	2, 3, 4	SAE 10, 7/8-14	SB-D3-0106AL
Steel	2, 3, 4	G1/2	SB-D3-0105ST
	2, 3, 4	SAE 10, 7/8-14	SB-D3-0106ST

The use of aluminium bodies is limited to a maximum operating pressure of 210 bar.

Spare Parts

Seal kits on request.

Caution!

- The packing foil is recyclable.
- The technical information regarding the product presented in this catalogue is for descriptive purposes only. It should not be construed in any case as a guaranteed representation of the product properties in the sense of the law.

ARGO-HYTOS s.r.o. CZ - 543 15 Vrchlabí
 Tel.: +420-499-403111, Fax: +420-499-403421
 E-mail: sales.cz@argo-hytos.com
 www.argo-hytos.com

- ❑ Hardened and precision working parts
- ❑ Flow rate setting with adjustment screw or with hand wheel
- ❑ Quiet and stable flow setting over complete pressure range
- ❑ Bypass port 2 may be fully pressurized
- ❑ Fine low-torque adjustment

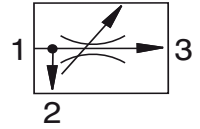

4

Functional Description

Throttle valves with pressure compensators are used to ensure a constant flow rate and thereby a constant speed of consumer (e.g. piston of actuator) independently on acting loads.

The valve consists of a body (1) with thread 7/8-14-UNF, bush (2) pressure compensator spool (3), adjusting screw (4) with locking nut and spring.

The working fluid enters the valve from its face side (1), goes through the throttle orifice in the spool and flows out through the radial holes (3) to the consu-

mer. The spool of the compensator keeps constant pressure gradient by draining off a part of fluid through the radial holes (2). Thereby the constant flow through the valve is assured. The value of the flow can be preset by adjusting the screw with lock nut. When the flowing in a reverse direction, the pressure compensator is functionless.

The valve body, adjustment screw and lock nut are zinc coated.

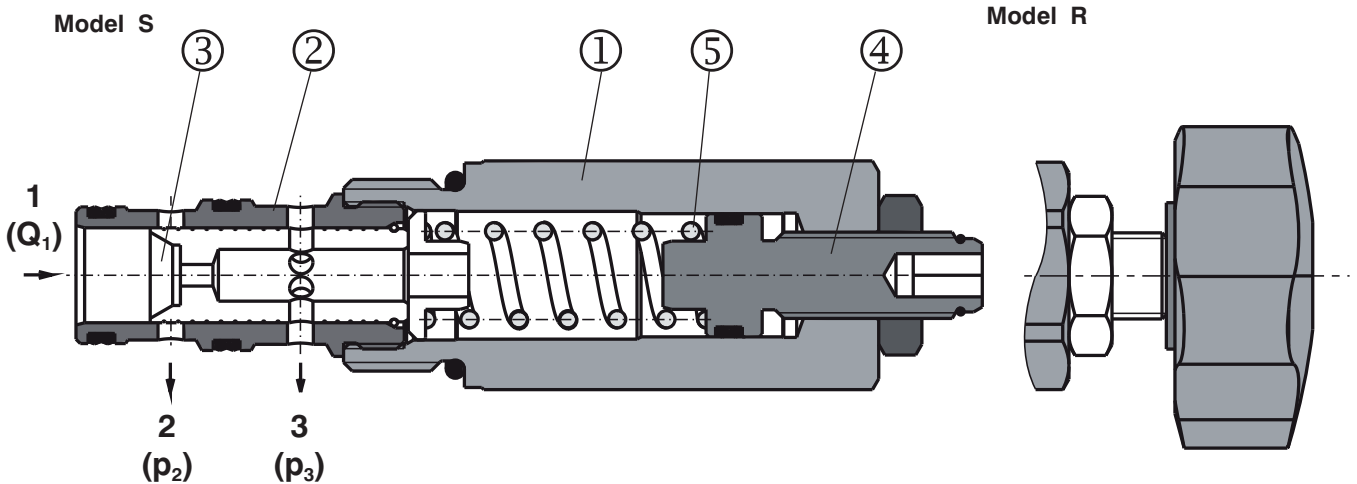

Ordering Code

SF32A-B3/

3 way Flow Control Valve
pressure compensated
7/8-14 UNF

no designation
V

Seals
NBR
FPM (Viton)

S
R

Adjustment option
Inside hexagon 5 mm
Adjustable handknob

High performance

H

10
14
22
30

Flow rate
Flow 5-10 L/min (1.32-2.64 GPM)
Flow 6-14 L/min (1.59-3.70 GPM)
Flow 11-22 L/min (2.91-5.81 GPM)
Flow 17-30 L/min (4.49-7.93 GPM)

Technical Data

Valve size	B3			
Cartridge thread	7/8-14 UNF-2A			
Nominal flow rates	10	14	22	30
Flow range	see Q-Δp characteristic			
Maximum working pressure	bar (PSI) 350 (5076)			
Hydraulic fluid	Hydraulic oils of power classes (HL, HLP) to DIN 51524			
Fluid temperature range NBR	°C (°F) -30... + 100 (-22 ... +212)			
Fluid temperature range FPM(Viton)	°C (°F) -20 ... +120 (-4 ... +248)			
Viscosity range	mm ² /s (SUS) 10 ... 500 (49 ... 2450)			
Maximum degree of fluid contamination	Class 21/18/15 to ISO 4406			
Weight	kg (lbs) 0,235 (0.518)			
Mounting position	unrestricted			
Valve body (data sheet HA0018)	SB-B3			

p-Q Characteristics

Measured at v = 32 mm²/s (156 SUS)

$$Q_3 = f(p_3 - p_2)$$

Q₃ : Flow 1 → 3
Δp = (p₃-p₂)
Q₁ = 50 L/min (13.21 GPM)

Flow rate 10

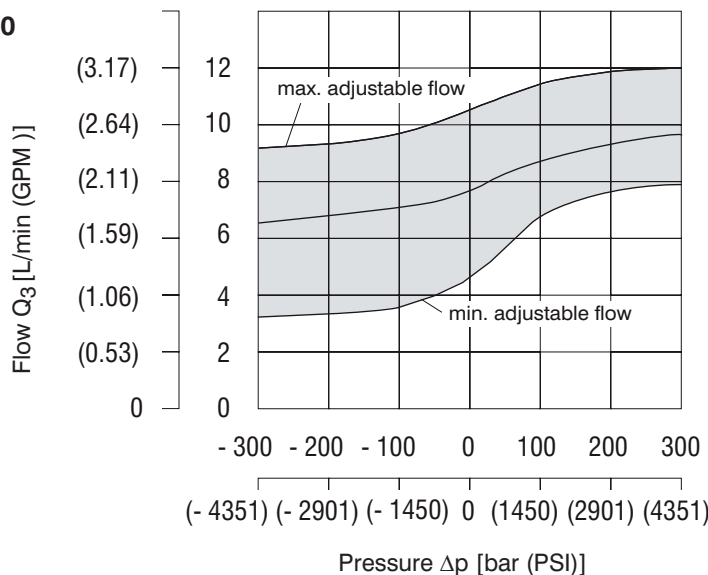

p-Q Characteristics

Measured at $v = 32 \text{ mm}^2/\text{s}$ (156 SUS)

$$Q_3 = f(p_3 - p_2)$$

Q_3 : Flow 1 → 3

$\Delta p = (p_3 - p_2)$

$Q_1 = 50 \text{ L/min}$ (13.21 GPM)

Flow rate 14

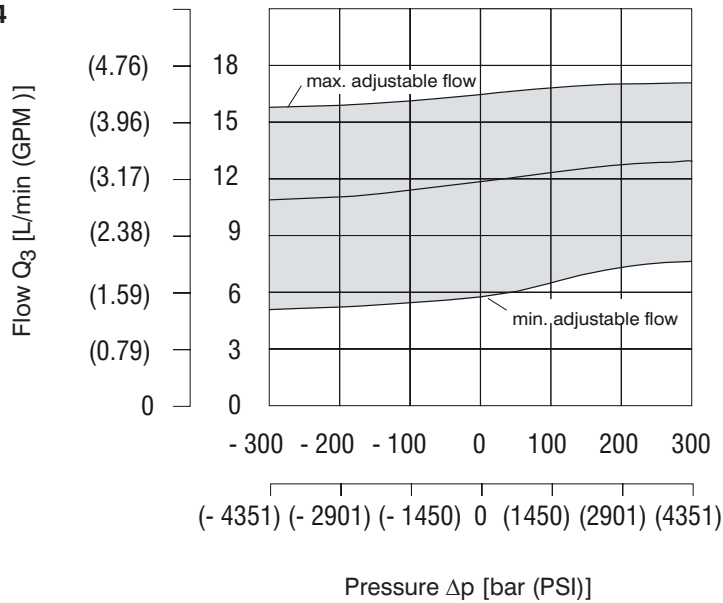

Flow rate 22

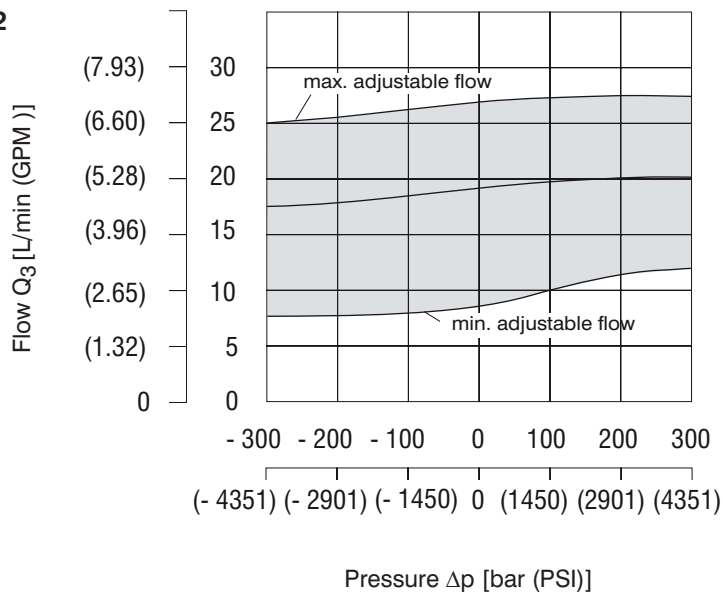

Flow rate 30

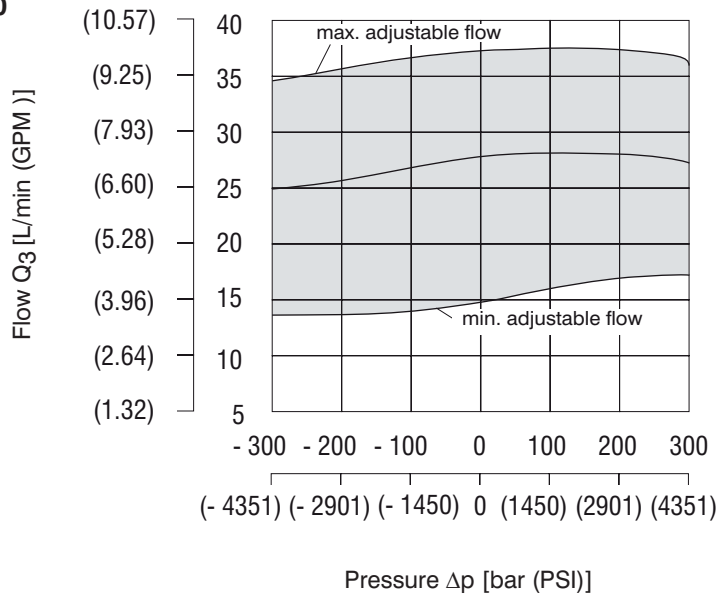

Valve Dimensions

Dimensions in millimeters (inches)

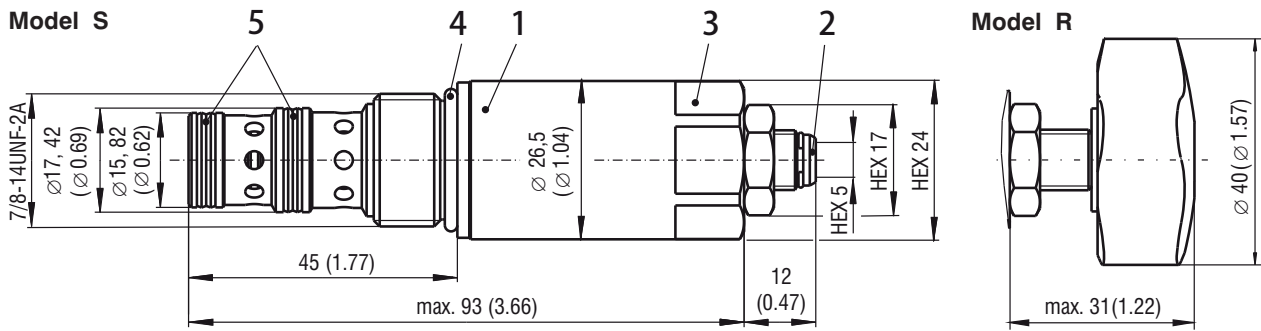

Cavity

Dimensions in millimeters (inches)

- 1 Type designation (stamped)
- 2 Screw for fine flow adjustment
 - inside HEX 5
 - anticlockwise rotation = flow decrease
 - clockwise rotation = flow increase
- 3 Spanner size 24 mm
tightening torque 60+5 Nm (44.3+3.7 lbf.ft)
- 4 Sealing: O-ring 19,4x2,1 (supplied with valve)
- 5 Sealing: Dualseal 17,47 x 15,07 x 3,1
11.87 x 14.27 x 3.1 (supplied with valve)

4

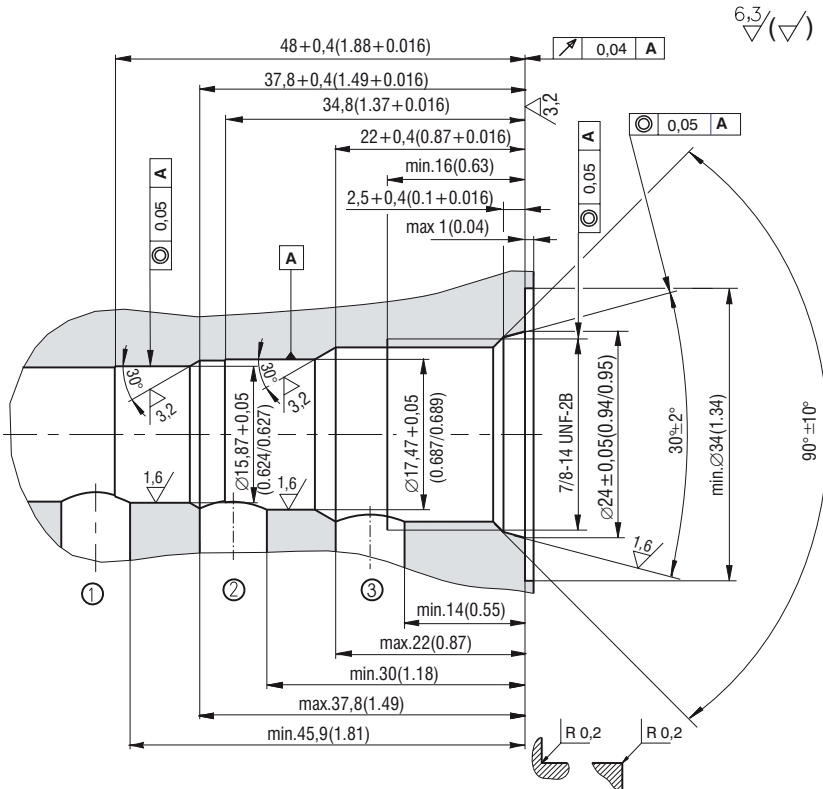

Spare Parts

Type	Dimensions, quantity		Ordering number
NBR	O-ring	Dualseal - PU	
	19.4 x 2.1(1 pc)	17.47 x 15.07 x 3.1(1pc)	20143900
		11.87 x 14.27 x 3.1(1pc)	24220800
FPM (Viton)	19.4 x 2.1(1 pc)		20158500
		17.47 x 15.07 x 3.1(1pc)	20144100
		11.87 x 14.27 x 3.1(1pc)	24220800

Caution!





- The plastic packaging is recyclable.
- Certified documentation is available per request.

ARGO-HYTOS s.r.o. CZ - 543 15 Vrchlabí
 tel.: +420-499-403 111
 e-mail: info.cz@argo-hytos.com
 www.argo-hytos.com

Overcentre Valves

5

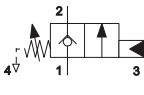
Overcentre Valves

Symbol example	Flow l/min (GPM)	Pressure bar (PSI)	Type Code	Cartridge	NFPA D02, CETOP 2; NG4	NFPA D03, CETOP 3; NG6	NFPA D05, CETOP 5, NG10	Line Mounted	Page	Data Sheet
Overcentre Valves										
	30 (8)	350 (5100)	SO5A-Q3/I	X				(X)	5.01	HA 5200
	90 (24)	350 (5100)	SO5A-R3/I	X				(X)	5.05	HA 5205
	140 (37)	420 (6100)	SO5A-T3/I	X				(X)	5.12	HA 5214
Overcentre Valves Part Balanced										
	30 (8)	350 (5100)	SOP5A-Q3/I	X				(X)	5.02	HA 5201
	90 (24)	350 (5100)	SOP5A-R3/I	X				(X)	5.06	HA 5206
	140 (37)	420 (6100)	SOP5A-T3/I	X				(X)	5.14	HA 5215
Overcentre Valves Fully Balanced - Air Ventilated										
	30 (8)	350 (5100)	SOB5A-Q3/I	X				(X)	5.03	HA 5202
	90 (24)	350 (5100)	SOB5A-R3/I	X				(X)	5.07	HA 5207
	120 (32)	350 (5100)	SOB5A-S3/I	X				(X)	5.10	HA 5211
Overcentre Valves Zero Differential										
	30 (8)	350 (5100)	SOZ5A-Q3/I	X				(X)	5.04	HA 5204
	90 (24)	350 (5100)	SOZD5A-R4/I	X					5.09	HA 5210
	180 (48)	400 (5800)	SOZD5A-S4/I	X					5.12	HA 5213
Overcentre Valves Fully Balanced - Internal Drainage										
	90 (24)	350 (5100)	SOBD5A-R4/I	X					5.08	HA 5208
	180 (48)	400 (5800)	SOBD5A-S4/I	X					5.11	HA 5212

- The valve prevents runaway in the event of a negative load
- Load-holding without leakage
- Pressure relief function protecting the actuator against overload and pressure peaks
- When installed into the actuator the valve can be used as a hose burst valve
- When used as pressure relief the check valve will act as an anti-cavitation valve
- The valve should be mounted as close as possible to the actuator
- Fits the same cavity as the Q3 check valve

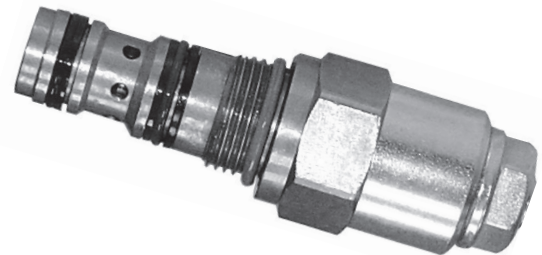
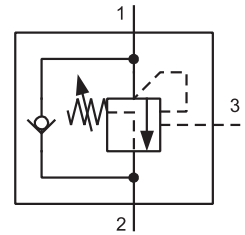

Functional Description

The valve consists of a seat by-pass, relief valve fitted with an auxiliary control with a differential piston and by-pass single-way valve serving for reverse direction of flow. The liquid is flowing through the single-way valve from the channel (2) to the channel (1) with a small pressure drop. In the opposite direction the single-way valve on the rear side of which a gate valve seat is fitted is pressed through the action of a spring and the load pressure against the spring-loaded valve gate valve. In this way the valve is nearly closed hermetically. If the pressure in the channel (1) exceeds a set up value of the spring force the gate valve is pressed out of the seat and the overpressure in that case is relieved into channel (2). For ensuring the function of holding the load the spring force should be set up to a value by 30 % higher when compared to an expected pressure exerted by the load.

If the load has to be moved it is possible to ensure it with the help of so called auxiliary control from the channel (3) by introducing already certain control pressure.

The control pressure is calculated in the following way:

$$\text{Control pressure} = \frac{\text{set up pressure} - \text{load pressure}}{\text{ratio of control}}$$

The ratio of control designates a ratio of surfaces of the differential slide valve cross-section area and its seat. Therefore, the necessary control pressure for opening the valve does not correspond to the difference between the set up pressure and load pressure however; it corresponds to the ratio of this difference and the control ratio. In the formula as mentioned above it is necessary to take into consideration that in differential cylinders it is necessary to add to the control ratio also the appropriate ratio of piston surfaces in the direction of movement.

As soon as the control pressure attains a necessary value the differential gate valve is moved out from the seat and then the way from the channel (1) to the channel (2) is released. If now the load tries to accelerate and be fast as for the oil supply the supply pressure decreases, therefore, also the control pressure in the channel (3) is decreased. The spring force tries to shut off the valve again, therefore, in consequence of which the flow from the consumer decreases and the inlet pressure to the consumer increases again. In this way it is ensured a constant inlet pressure by means of which the movement of the load can be controlled.

As for appropriate basic surface finish the external parts are zinc coated.

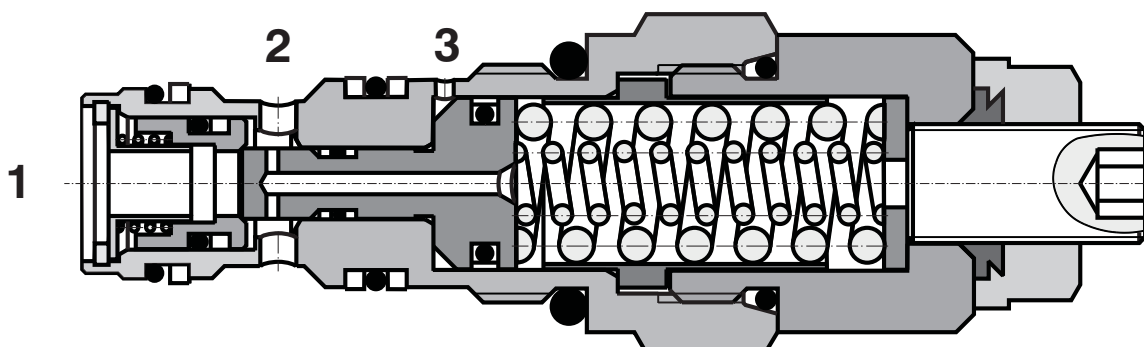

Ordering Code

SO5A-Q3/I



Overcentre Valve

NBR

No designation

Pilot ratio

For applications with varying load	2,5:1	2
Standard	5:1	5
For applications with a constant load	10:1	10

Technical Data

Cavity		M20 x 1,5
Maximum flow	L/min	30
Max. pressure	bar	270
Max. input pressure	bar	350
Pressure drops	bar	see Δp - Q characteristics
Hydraulic fluid		Hydraulic oil (HL, HLP) according to DIN 51524
Fluid temperature range	°C	-20 ... +90
Viscosity	mm ² /s	20 ... 400
Maximum degree of fluid contamination		according to ISO 4406, Class 21/18/15
Weight	kg	0,15
Maximum valve tightening torque in valve body or in control block	Nm	45 ⁺²
Mounting position		Unrestricted

Δp -Q Characteristics

Measured at $v = 40 \text{ mm}^2/\text{s}$

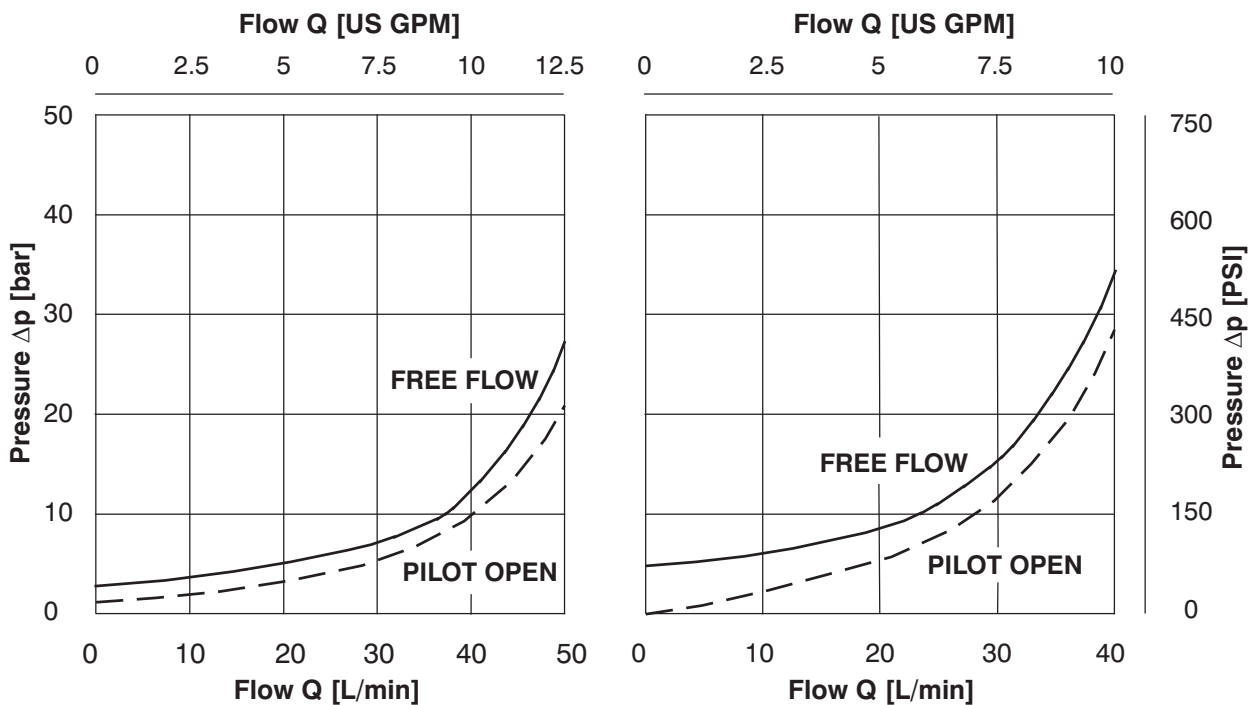

5

Dimensions

Measurements in millimeters

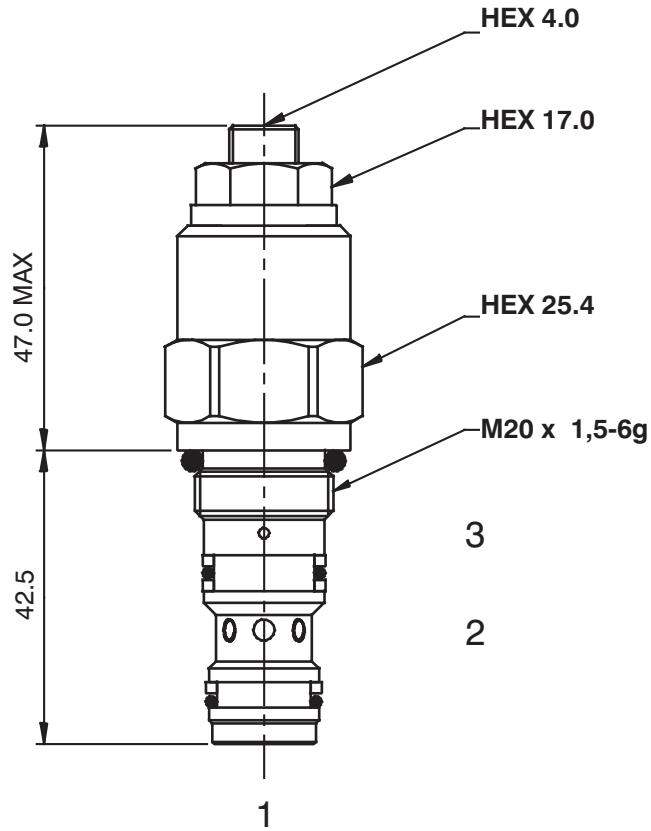

Cavity

Measurements in millimeters

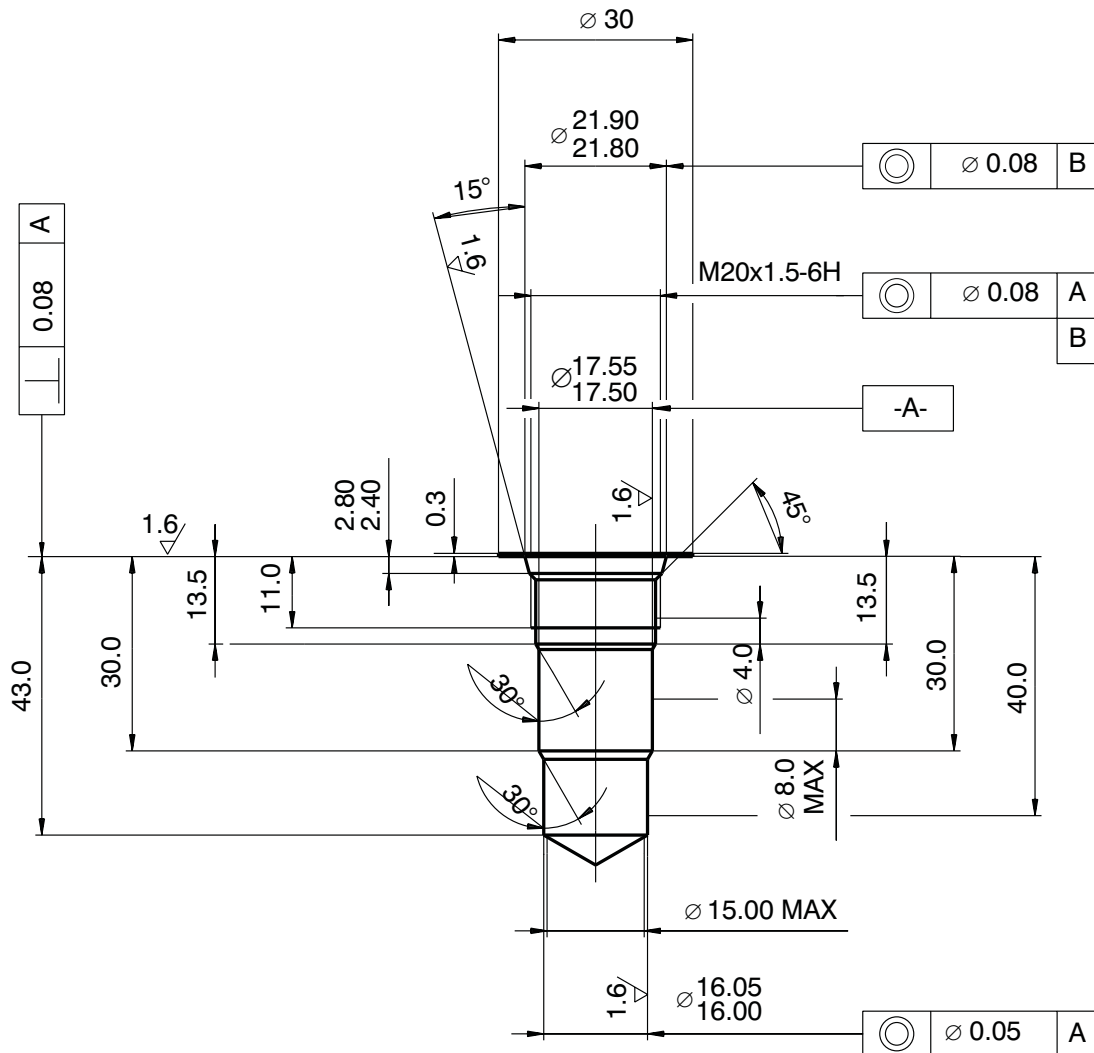

Valve Bodies

Measurements in millimeters

ISO A

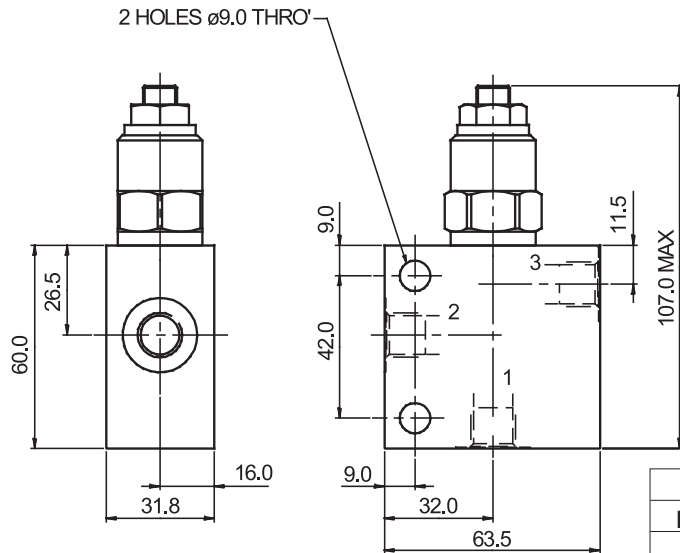
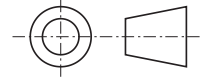

Body without valve			
Material	Ports	Port size	Type code
Aluminium	1, 2	G3/8	SB-Q3-0103AL
	3	G1/4	
	1, 2	SAE 8, 3/4-16	SB-Q3-0104AL
	3	SAE 6, 9/16-18	
Steel	1, 2	G3/8	SB-Q3-0103ST
	3	G1/4	
	1, 2	SAE 8, 3/4-16	SB-Q3-0104ST
	3	SAE 6, 9/16-18	

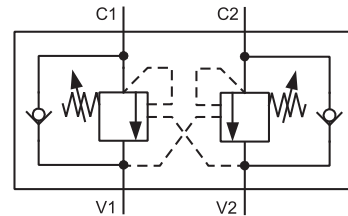
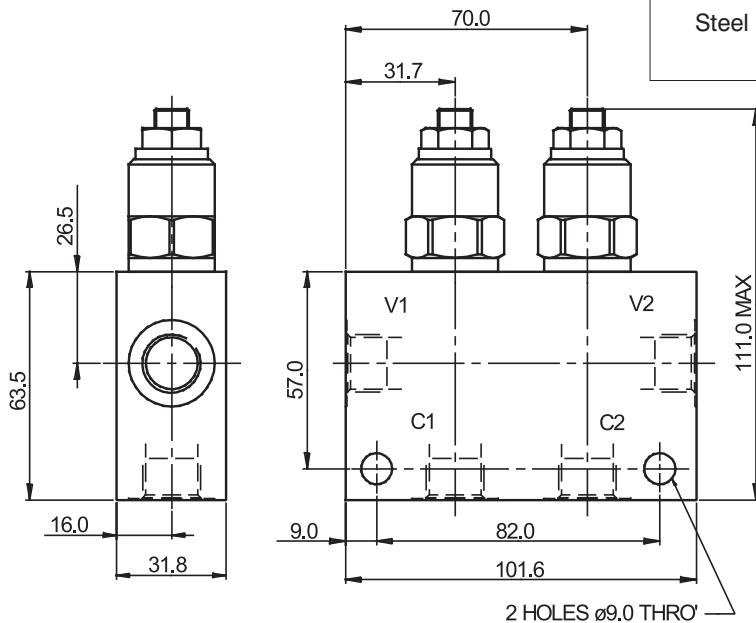

Dual body without valve			
Material	Ports	Port size	Type code
Aluminium	C1, C2, V1, V2	G3/8	SB-Q4-0203AL
	C1, C2, V1, V2	SAE 8, 3/4-16	SB-Q4-0204AL
Steel	C1, C2, V1, V2	G3/8	SB-Q4-0203ST
	C1, C2, V1, V2	SAE 8, 3/4-16	SB-Q4-0204ST

The use of aluminium bodies is limited to a maximum operating pressure of 210 bar.

Spare Parts

Seal kits on request.

Caution!

- The packing foil is recyclable.
- The technical information regarding the product presented in this catalogue is for descriptive purposes only. It should not be construed in any case as a guaranteed representation of the product properties in the sense of the law.

ARGO-HYTOS s.r.o. CZ - 543 15 Vrchlaví
Tel.: +420-499-403111, Fax: +420-499-403421
E-mail: sales.cz@argo-hytos.com
www.argo-hytos.com

- The valve prevents runaway in the event of a negative load
- Load-holding without leakage
- Pressure relief function protecting the actuator against overload and pressure peaks
- When installed into the actuator the valve can be used as a hose burst valve
- When used as pressure relief the check valve will act as an anti-cavitation valve
- Relief setting is unaffected by back pressure
- The valve should be mounted as close as possible to the actuator
- Fits the same cavity as the Q3 check valve

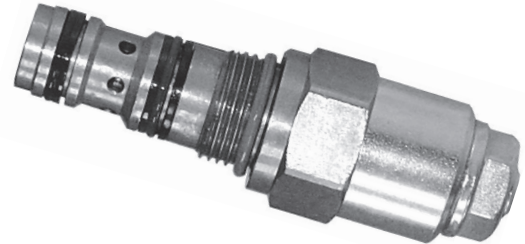
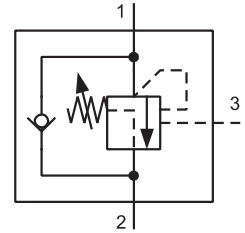

Functional Description

The valve consists of a seat by-pass, relief valve fitted with an auxiliary control with a differential piston and by-pass single-way valve serving for reverse direction of flow. The liquid is flowing through the single-way valve from the channel (2) to the channel (1) with a small pressure drop. In the opposite direction the single-way valve on the rear side of which a gate valve seat is fitted is pressed through the action of a spring and the load pressure against the spring-loaded valve gate valve. In this way the valve is nearly closed hermetically. If the pressure in the channel (1) exceeds a set up value of the spring force the gate valve is pressed out of the seat and the overpressure in that case is relieved into channel (2). For ensuring the function of holding the load the spring force should be set up to a value by 30 % higher when compared to an expected pressure exerted by the load. If the load has to be moved it is possible to ensure it with the help of so called auxiliary control from the channel (3) by introducing already certain control pressure.

The control pressure is calculated in the following way:

$$\text{Control pressure} = \frac{\text{set up pressure} - \text{load pressure}}{\text{ratio of control}}$$

The ratio of control designates a ratio of surfaces of the differential slide valve cross-section area and its

seat. Therefore, the necessary control pressure for opening the valve does not correspond to the difference between the set up pressure and load pressure however; it corresponds to the ratio of this difference and the control ratio. In the formula as mentioned above it is necessary to take into consideration that in differential cylinders it is necessary to add to the control ratio also the appropriate ratio of piston surfaces in the direction of movement.

As soon as the control pressure attains a necessary value the differential gate valve is moved out from the seat and then the way from the channel (1) to the channel (2) is released. If now the load tries to accelerate and be fast as for the oil supply the supply pressure decreases, therefore, also the control pressure in the channel (3) is decreased. The spring force tries to shut off the valve again, therefore, in consequence of which the flow from the consumer decreases and the inlet pressure to the consumer increases again. In this way it is ensured a constant inlet pressure by means of which the movement of the load can be controlled.

Dynamic pressures in the outlet do not influence the set up value thanks to a special arrangement of the slide valve. However, it is necessary to take care of the fact the control channel is independent on the dynamic pressure.

As for appropriate basic surface finish the external parts are zinc coated.

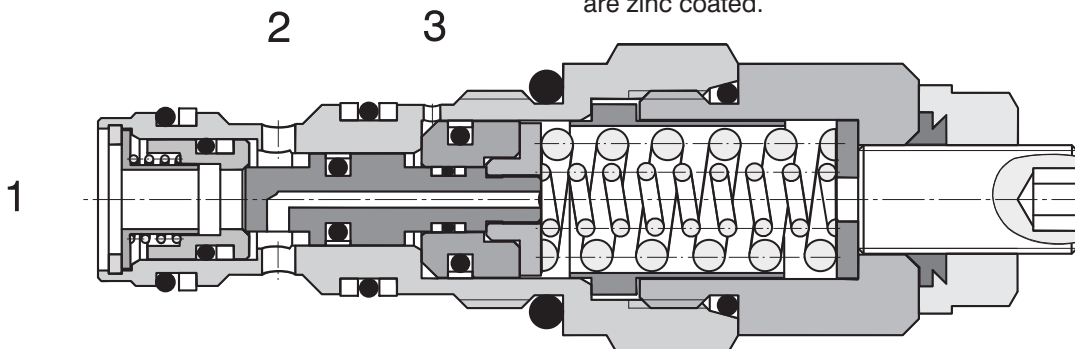

Ordering Code

SOP5A-Q3/I

Overcentre valve
part balanced

No designation

Seals
NBR

Pilot ratio
Standard 4:1

4

Technical Data

Cavity		M20 x 1,5
Maximum flow	L/min	30
Max. pressure	bar	270
Max. input pressure	bar	350
Pressure drops	bar	see $\Delta p - Q$ characteristics
Hydraulic fluid		Hydraulic oil (HM, HV) according to DIN 51524
Fluid temperature range	°C	-20 ... +90
Viscosity	mm ² /s	20 ... 400
Maximum degree of fluid contamination		according to ISO 4406, Class 21/18/15
Weight	kg	0,15
Maximum valve tightening torque in valve body or in control block	Nm	45 ⁺²
Mounting position		Unrestricted

Δp -Q Characteristics

Measured at $v = 40 \text{ mm}^2/\text{s}$

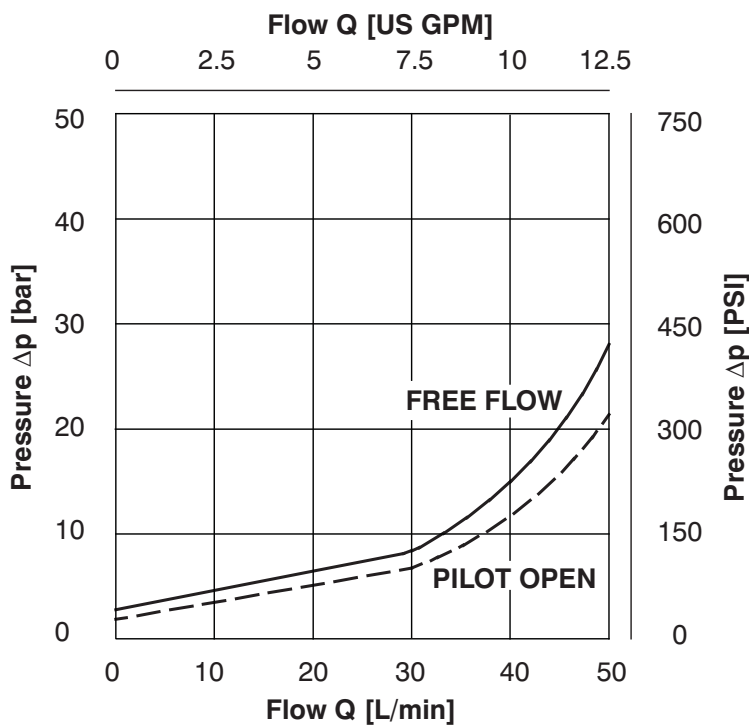

Dimensions

Measurements in millimeters

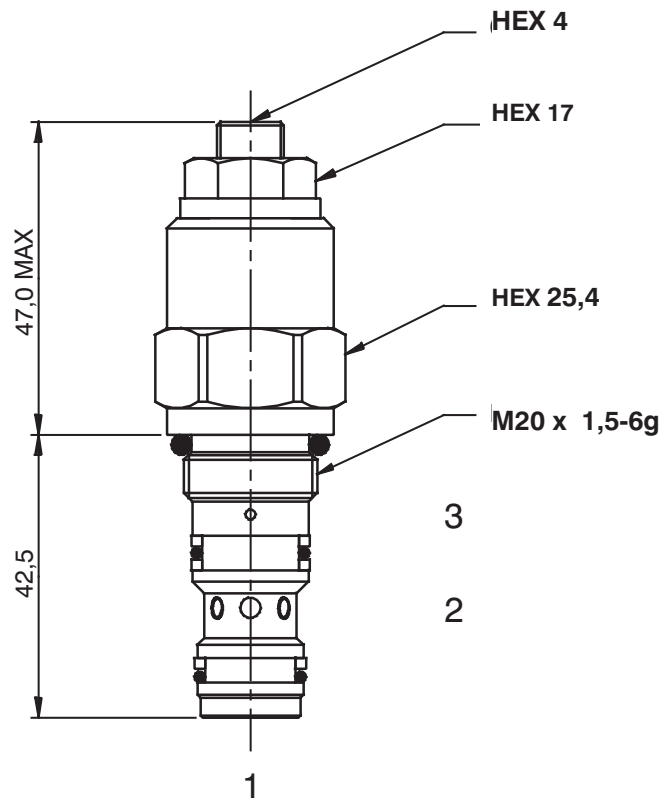

Cavity

Measurements in millimeters

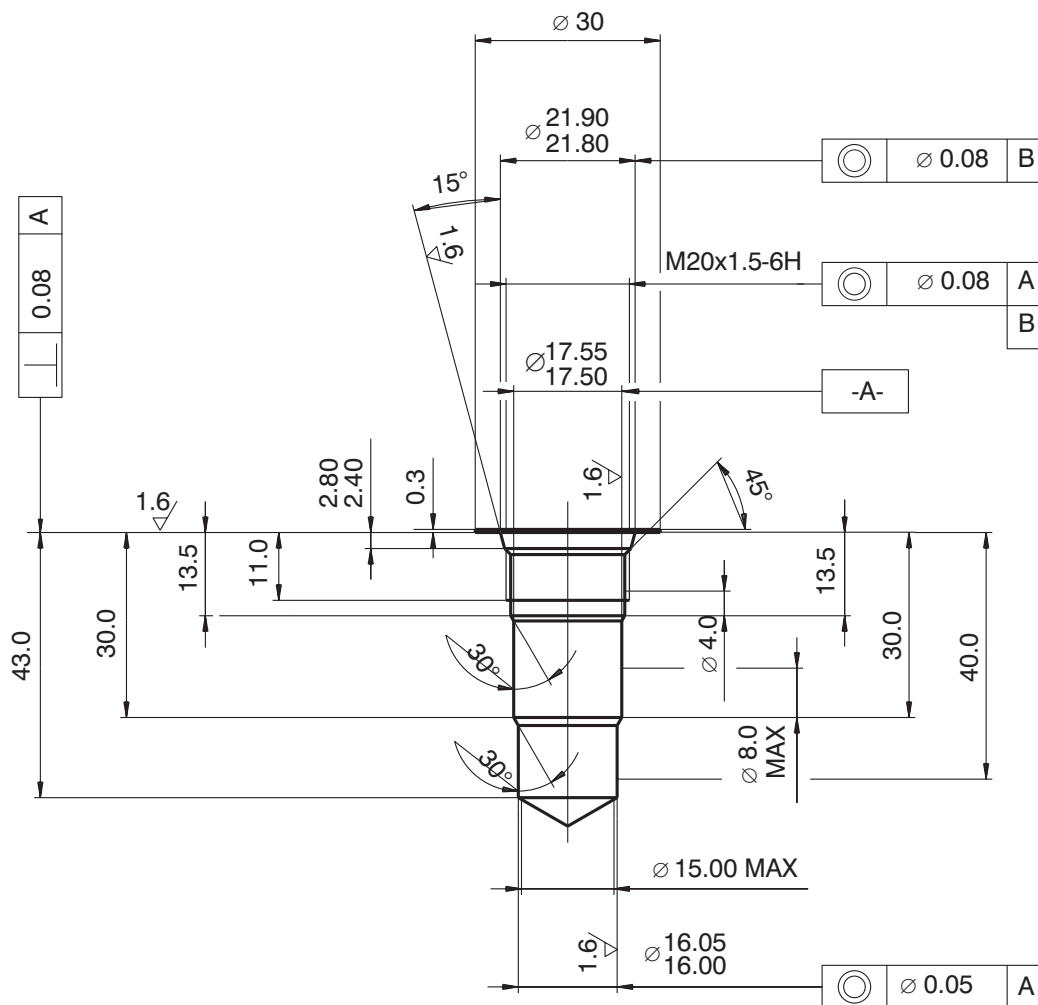

5

Valve Bodies

Measurements in millimeters

ISO A

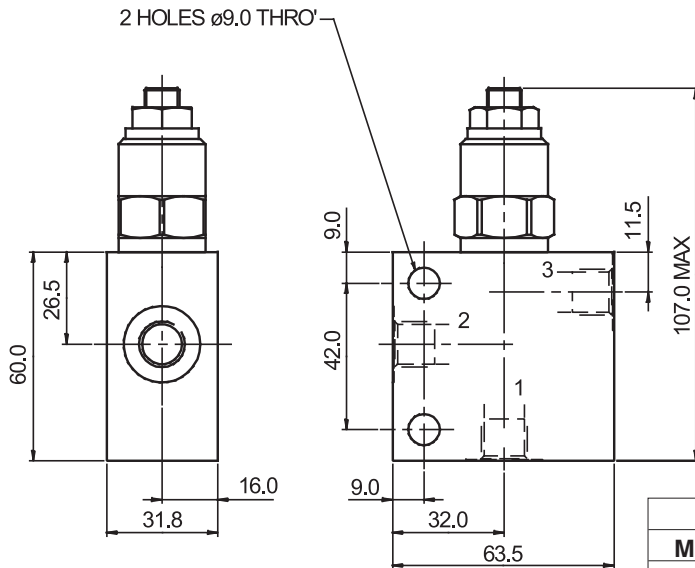
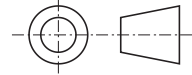

Body without valve			
Material	Ports	Port size	Type code
Aluminium	1, 2	G3/8	SB-Q3-0103AL
	3	G1/4	
	1, 2	SAE 8, 3/4-16	SB-Q3-0104AL
	3	SAE 6, 9/16-18	
Steel	1, 2	G3/8	SB-Q3-0103ST
	3	G1/4	
	1, 2	SAE 8, 3/4-16	SB-Q3-0104ST
	3	SAE 6, 9/16-18	

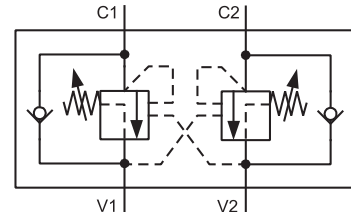
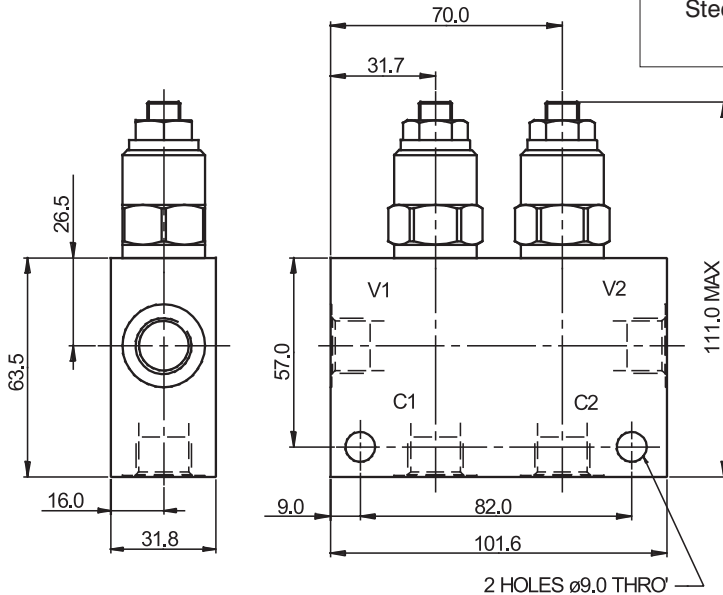

Dual body without valve			
Material	Ports	Port size	Type code
Aluminium	C1, C2, V1, V2	G3/8	SB-Q4-0203AL
	C1, C2, V1, V2	SAE 8, 3/4-16	SB-Q4-0204AL
Steel	C1, C2, V1, V2	G3/8	SB-Q4-0203ST
	C1, C2, V1, V2	SAE 8, 3/4-16	SB-Q4-0204ST

The use of aluminium bodies is limited to a maximum operating pressure of 210 bar.

Spare Parts

Seal kits on request.

Caution!

- The packing foil is recyclable.
- The technical information regarding the product presented in this catalogue is for descriptive purposes only. It should not be construed in any case as a guaranteed representation of the product properties in the sense of the law.

ARGO-HYTOS s.r.o. CZ - 543 15 Vrchlaví
 Tel.: +420-499-403111, Fax: +420-499-403421
 E-mail: sales.cz@argo-hytos.com
 www.argo-hytos.com

- The valve prevents runaway in the event of a negative load
- Load-holding without leakage
- Pressure relief function protecting the actuator against overload and pressure peaks
- When installed into the actuator the valve can be used as a hose burst valve
- When used as pressure relief the check valve will act as an anti-cavitation valve
- Relief setting is unaffected by back pressure
- The valve should be mounted as close as possible to the actuator
- Fits the same cavity as the Q3 check valve

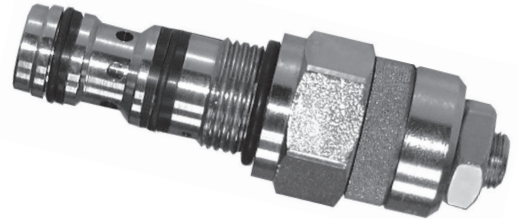
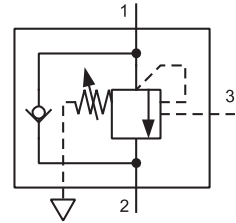

Functional Description

The valve consists of a seat by-pass, relief valve fitted with an auxiliary control with a differential piston and by-pass single-way valve serving for reverse direction of flow. The liquid is flowing through the single-way valve from the channel (2) to the channel (1) with a small pressure drop. In the opposite direction the single-way valve on the rear side of which a gate valve seat is fitted is pressed through the action of a spring and the load pressure against the spring-loaded valve gate valve. In this way the valve is nearly closed hermetically. If the pressure in the channel (1) exceeds a set up value of the spring force the gate valve is pressed out of the seat and the overpressure in that case is relieved into channel (2). For ensuring the function of holding the load the spring force should be set up to a value by 30 % higher when compared to an expected pressure exerted by the load.

If the load has to be moved it is possible to ensure it with the help of so called auxiliary control from the channel (3) by introducing already certain control pressure.

The control pressure is calculated in the following way:

$$\text{Control pressure} = \frac{\text{set up pressure} - \text{load pressure}}{\text{ratio of control}}$$

The ratio of control designates a ratio of surfaces of the differential slide valve cross-section area and its seat. Therefore, the necessary control pressure for opening the valve does not correspond to

the difference between the set up pressure and load pressure however; it corresponds to the ratio of this difference and the control ratio. In the formula as mentioned above it is necessary to take into consideration that in differential cylinders it is necessary to add to the control ratio also the appropriate ratio of piston surfaces in the direction of movement.

As soon as the control pressure attains a necessary value the differential gate valve is moved out from the seat and then the way from the channel (1) to the channel (2) is released. If now the load tries to accelerate and be fast as for the oil supply the supply pressure decreases, therefore, also the control pressure in the channel (3) is decreased. The spring force tries to shut off the valve again, therefore, in consequence of which the flow from the consumer decreases and the inlet pressure to the consumer increases again. In this way it is ensured a constant inlet pressure by means of which the movement of the load can be controlled.

Dynamic pressures in the outlet do not influence the set up value thanks to a special arrangement of the slide valve. However, it is necessary to take care of the fact the control channel is independent on the dynamic pressure.

As for appropriate basic surface finish the external parts are zinc coated.

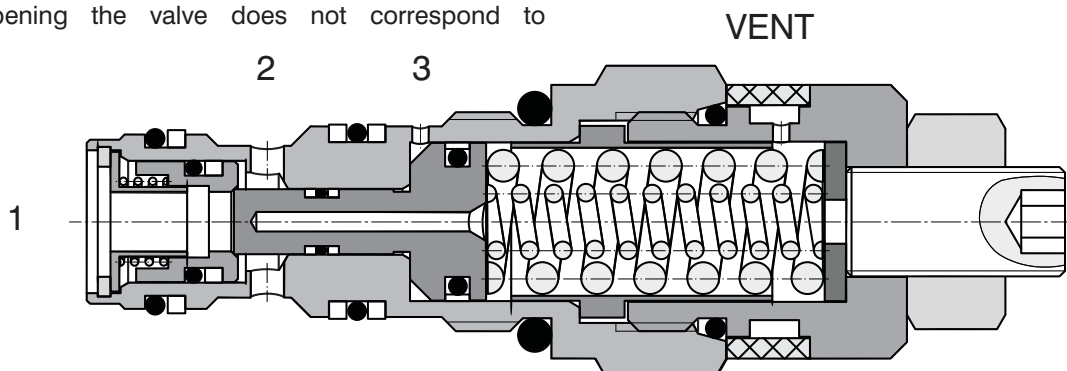

Ordering Code

SOB5A-Q3/I

Overcentre valve
Fully Balanced

No designation

Seals
NBR

Pilot ratio
Standard 5:1

5

Technical Data

Cavity		M20 x 1,5
Maximum flow	L/min	30
Max. pressure	bar	270
Max. input pressure	bar	350
Pressure drops	bar	see $\Delta p - Q$ characteristics
Hydraulic fluid		Hydraulic oil (HM, HV) according to DIN 51524
Fluid temperature range	°C	-20 ... +90
Viscosity	mm ² /s	20 ... 400
Maximum degree of fluid contamination		according to ISO 4406, Class 21/18/15
Weight	kg	0,14
Maximum valve tightening torque in valve body or in control block	Nm	45 ⁺²
Mounting position		Unrestricted

$\Delta p - Q$ Characteristics

Measured at $\nu = 40 \text{ mm}^2/\text{s}$

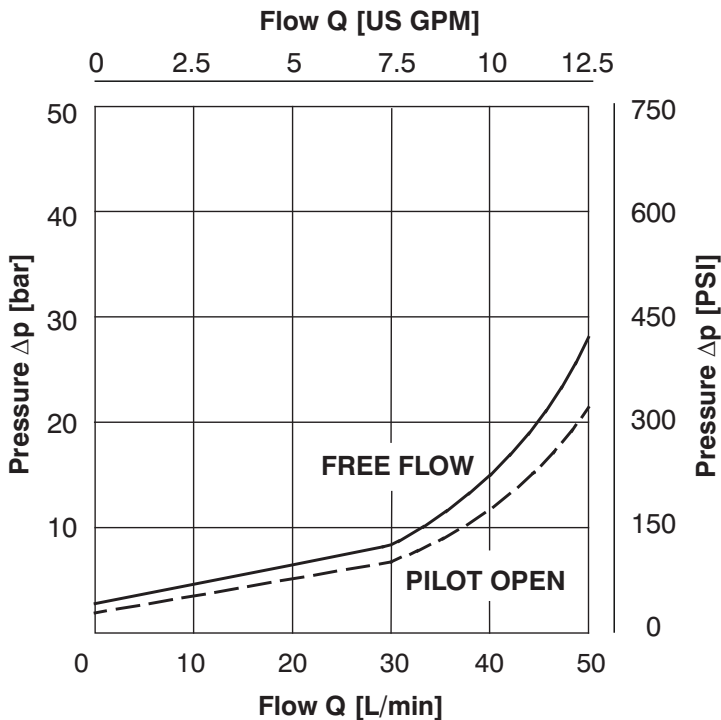

Dimensions

Measurements in millimeters

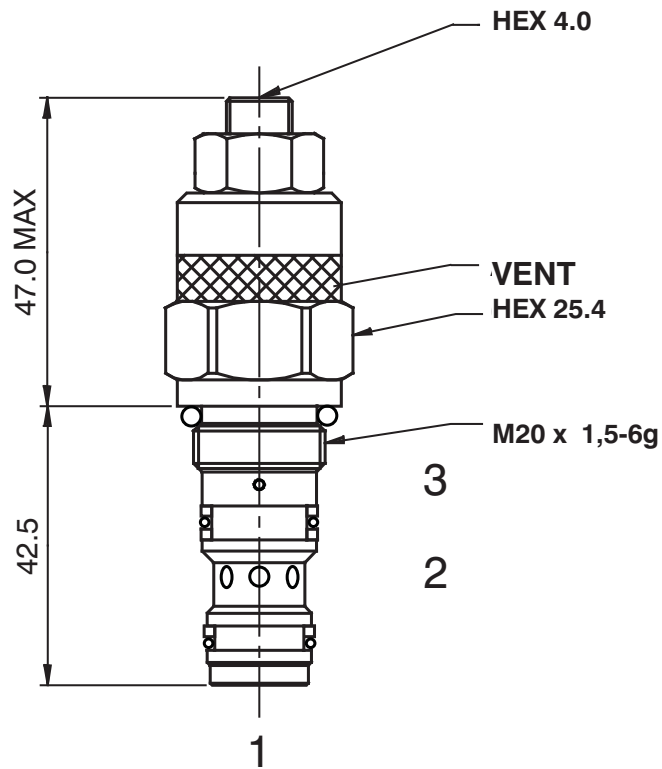

Cavity

Measurements in millimeters

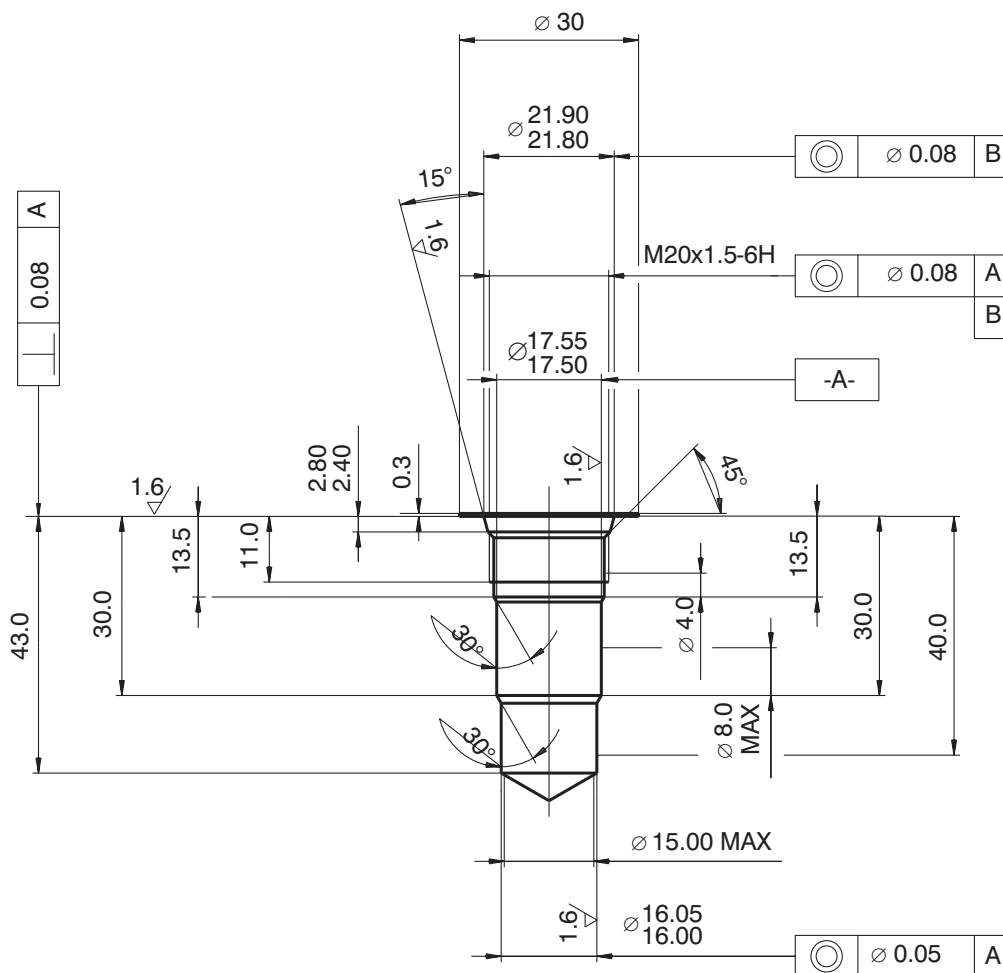

5

Valve Bodies

Measurements in millimeters

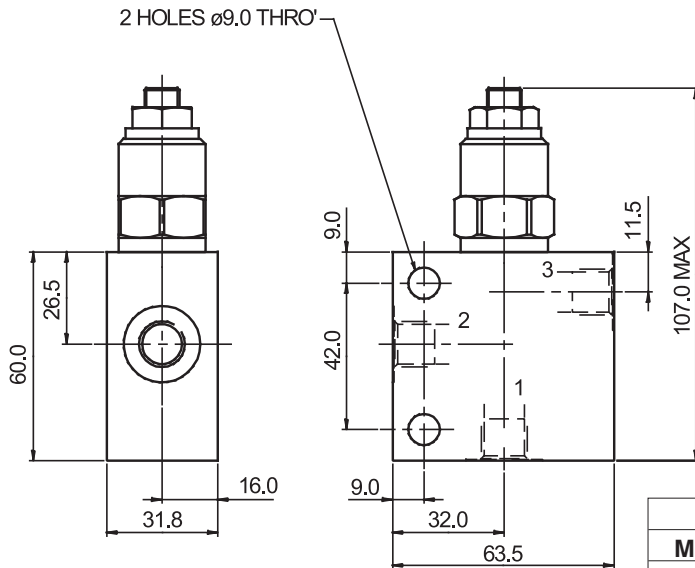

ISO A

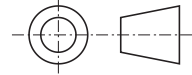

Body without valve			
Material	Ports	Port size	Type code
Aluminium	1, 2	G3/8	SB-Q3-0103AL
	3	G1/4	
	1, 2	SAE 8, 3/4-16	SB-Q3-0104AL
	3	SAE 6, 9/16-18	
Steel	1, 2	G3/8	SB-Q3-0103ST
	3	G1/4	
	1, 2	SAE 8, 3/4-16	SB-Q3-0104ST
	3	SAE 6, 9/16-18	

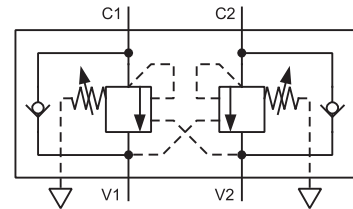
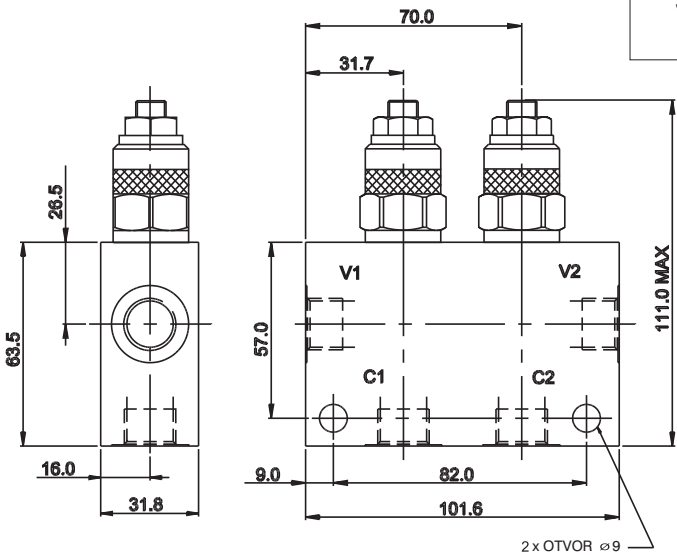

Dual body without valve			
Material	Ports	Port size	Type code
Aluminium	C1, C2, V1, V2	G3/8	SB-Q4-0203AL
	C1, C2, V1, V2	SAE 8, 3/4-16	SB-Q4-0204AL
Steel	C1, C2, V1, V2	G3/8	SB-Q4-0203ST
	C1, C2, V1, V2	SAE 8, 3/4-16	SB-Q4-0204ST

The use of aluminium bodies is limited to a maximum operating pressure of 210 bar.

Spare Parts

Seal kits on request.

Caution!

- The packing foil is recyclable.
- The technical information regarding the product presented in this catalogue is for descriptive purposes only. It should not be construed in any case as a guaranteed representation of the product properties in the sense of the law.

ARGO-HYTOS s.r.o. CZ - 543 15 Vrchlaví
 Tel.: +420-499-403111, Fax: +420-499-403421
 E-mail: sales.cz@argo-hytos.com
 www.argo-hytos.com

- The valve prevents runaway in the event of a negative load
- Smooth and continuous motion by maintaining a constant back pressure
- Load-holding without leakage
- When installed into the actuator the valve can be used as a hose burst valve
- The valve should be mounted as close as possible to the actuator
- Fits the same cavity as the Q3 check valve

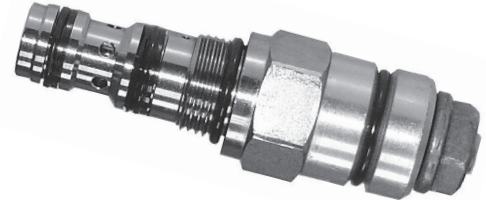
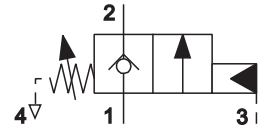

Functional Description

The valve consists of a seat relief valve fitted with an auxiliary control and by-pass single-way valve serving for reverse direction of flow. The liquid is flowing through the single-way valve from the channel (2) to the channel (1) with a small pressure drop. In the opposite direction the single-way valve on the rear side of which a gate valve seat is fitted is pressed through the action of a spring and the load pressure against the spring-loaded valve gate valve. In this way the valve is nearly closed hermetically. For ensuring the function of holding the load the spring force should be set up to a value by 30 % higher when compared to an expected pressure exerted by the load. If a load pressure caused by the action of the force on the consumer or in consequence of the liquid thermal dilatation exceeds a set up value of the spring force the gate valve is pressed out of the seat and the overpressure in that case is relieved from channel (1) to channel (2).

If the load has to be moved in opposite direction from the other connection of the consumer being in that case under pressure it is possible to ensure it with the help of so called auxiliary control from the channel (3) by introducing already certain control pressure.

The necessary control pressure for opening the valve corresponds to the difference between the set up pressure and load pressure. In the formula as mentioned above it is necessary to take into consideration that in differential cylinders it is necessary to take into consideration the relation of surfaces of the cylinder piston in the direction of movement.

As soon as the control pressure attains a necessary value the gate valve is moved out from the seat and then the way from the channel (1) to the channel (2) is released.

If now the load tries to accelerate and be fast as for the oil supply the supply pressure decreases, therefore, also the control pressure in the channel (3) is reduced. The spring force tries to shut off the valve again, therefore, in consequence of which the supply flow to the consumer is reduced and the inlet pressure increases again. In this way it is ensured a constant inlet pressure by means of which it would be possible to control the movement of the load.

As for appropriate basic surface finish the external parts are zinc coated.

The control pressure is calculated in the following way:

Control pressure = set up pressure – load pressure.

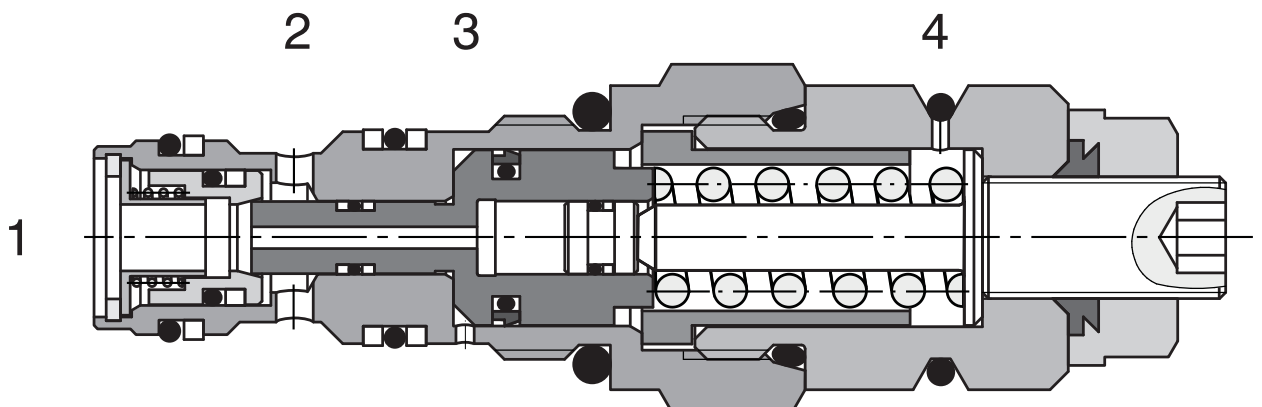

Ordering Code

SOZ5A-Q3/I

Overcentre Valve
zero differential

No designation

Seals
NBR

Preassare range
5 - 20 bar

2

Factory setting 10 bar for Q=4.8L/min

Technical Data

Cavity		M20 x 1,5
Maximum flow	L/min	30
Max. pressure	bar	350
Max. input pressure	bar	5 - 20
Pressure drops	bar	see Δp - Q characteristics
Hydraulic fluid		Hydraulic oil (HM, HV) according to DIN 51524
Fluid temperature range	°C	-20 ... +90
Viscosity	mm ² /s	20 ... 400
Maximum degree of fluid contamination		according to ISO 4406, Class 21/18/15
Weight	kg	0,15
Maximum valve tightening torque in valve body or in control block	Nm	45 ⁺²
Mounting position		Unrestricted

Δp -Q Characteristics

Measured at $v = 40 \text{ mm}^2/\text{s}$

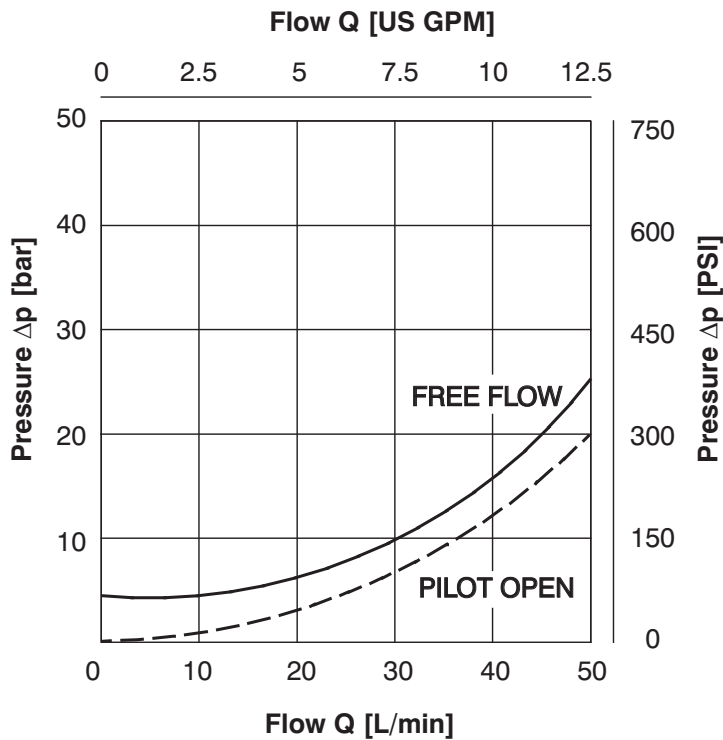

Dimensions

Measurements in millimeters

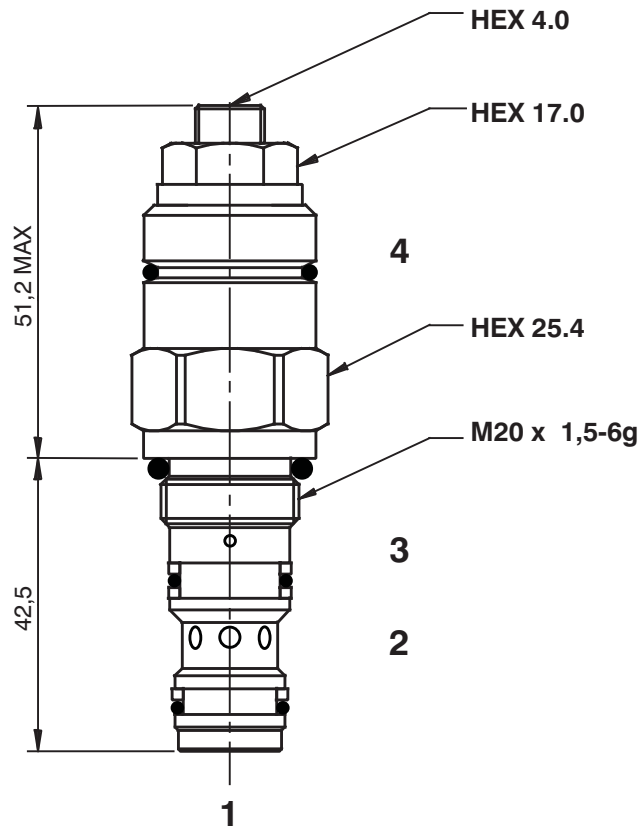

Cavity

Measurements in millimeters

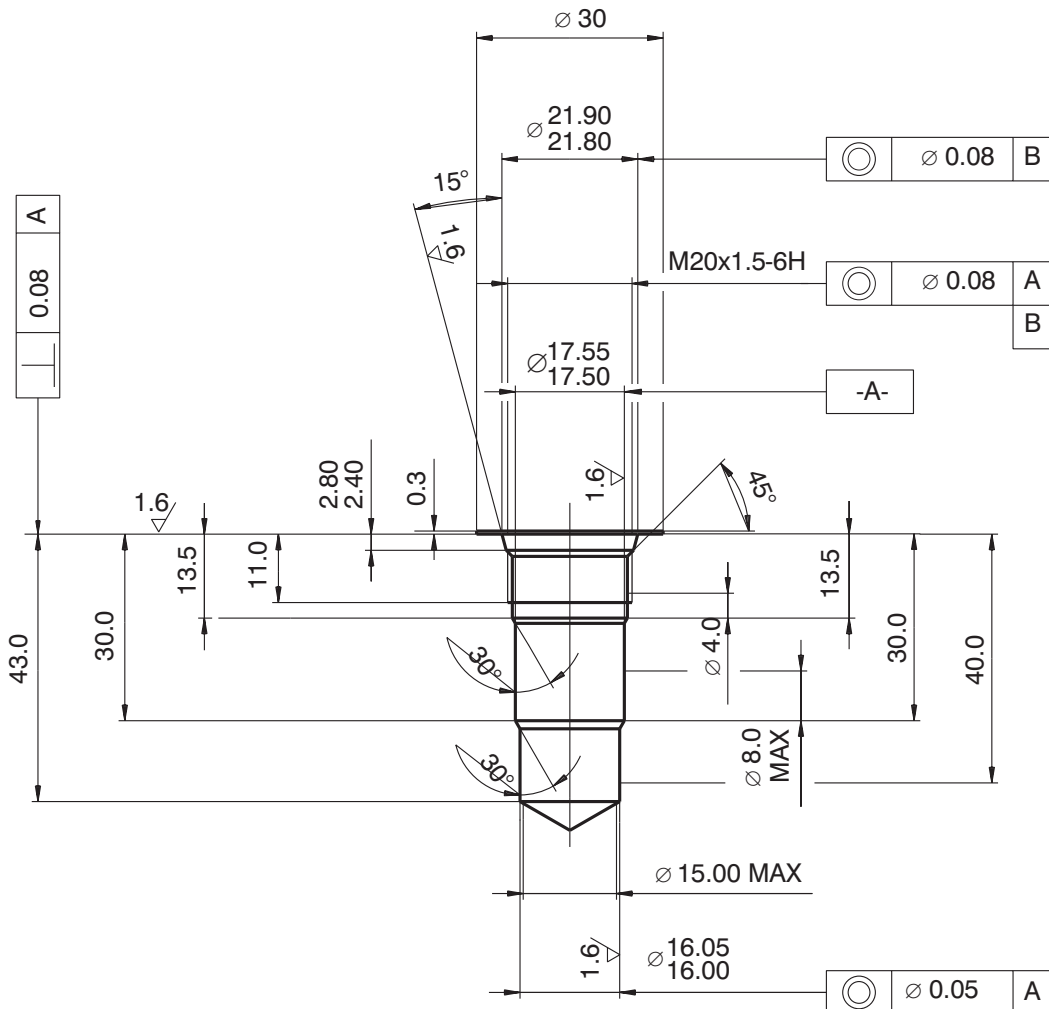

5

Valve Bodies

Measurements in millimeters

ISO A

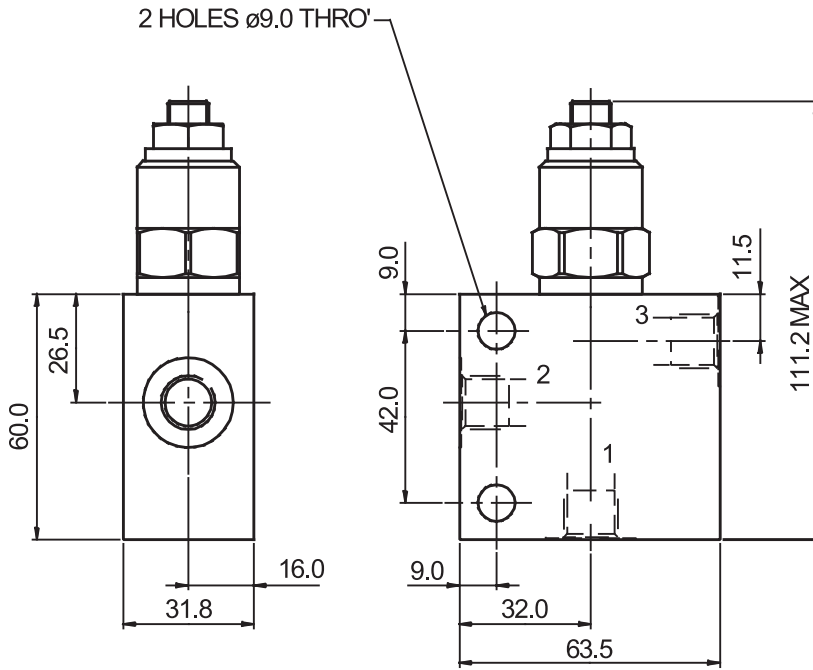
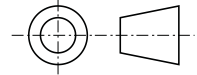

Body without valve			
Material	Ports	Port size	Type code
Aluminium	1, 2	G3/8	SB-Q3-0103AL
	3	G1/4	
	1, 2	SAE 8, 3/4-16	SB-Q3-0104AL
	3	SAE 6, 9/16-18	
Steel	1, 2	G3/8	SB-Q3-0103ST
	3	G1/4	
	1, 2	SAE 8, 3/4-16	SB-Q3-0104ST
	3	SAE 6, 9/16-18	

The use of aluminium bodies is limited to a maximum operating pressure of 210 bar.

Spare Parts

Seal kits on request.

Caution!

- The packing foil is recyclable.
- The technical information regarding the product presented in this catalogue is for descriptive purposes only. It should not be construed in any case as a guaranteed representation of the product properties in the sense of the law.

ARGO-HYTOS s.r.o. CZ - 543 15 Vrchlaví
 Tel.: +420-499-403111, Fax: +420-499-403421
 E-mail: sales.cz@argo-hytos.com
 www.argo-hytos.com

5

- The valve prevents runaway in the event of a negative load
- Load-holding with minimal leakage
- Pressure relief function protecting the actuator against overload and pressure peaks
- When installed into the actuator the valve can be used as a hose burst valve
- When installed into the actuator the valve can be used as a hose burst valve
- The valve should be mounted as close as possible to the actuator
- Fits the same cavity as the R3 check valve

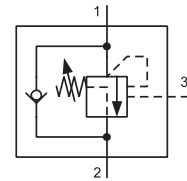

Functional Description

The valve consists of a seat by-pass, relief valve fitted with an auxiliary control with a differential piston and by-pass single-way valve serving for reverse direction of flow. The liquid is flowing through the single-way valve from the channel (2) to the channel (1) with a small pressure drop. In the opposite direction the single-way valve on the rear side of which a gate valve seat is fitted is pressed through the action of a spring and the load pressure against the spring-loaded valve gate valve. In this way the valve is nearly closed hermetically. If the pressure in the channel (1) exceeds a set up value of the spring force the gate valve is pressed out of the seat and the overpressure in that case is relieved into channel (2). For ensuring the function of holding the load the spring force should be set up to a value by 30 % higher when compared to an expected pressure exerted by the load. If the load has to be moved it is possible to ensure it with the help of so called auxiliary control from the channel (3) by introducing already certain control pressure.

The control pressure is calculated in the following way:

$$\text{Control pressure} = \frac{\text{set up pressure} - \text{load pressure}}{\text{ratio of control}}$$

The ratio of control designates a ratio of surfaces of the differential slide valve cross-section area and its seat. Therefore, the necessary control pressure for opening the valve does not correspond to the difference between

the set up pressure and load pressure however; it corresponds to the ratio of this difference and the control ratio. In the formula as mentioned above it is necessary to take into consideration that in differential cylinders it is necessary to add to the control ratio also the appropriate ratio of piston surfaces in the direction of movement.

As soon as the control pressure attains a necessary value the differential gate valve is moved out from the seat and then the way from the channel (1) to the channel (2) is released. If now the load tries to accelerate and be fast as for the oil supply the supply pressure decreases, therefore, also the control pressure in the channel (3) is decreased. The spring force tries to shut off the valve again, therefore, in consequence of which the flow from the consumer decreases and the inlet pressure to the consumer increases again. In this way it is ensured a constant inlet pressure by means of which the movement of the load can be controlled.

Dynamic pressures in the outlet do not influence the set up value thanks to a special arrangement of the slide valve. However, it is necessary to take care of the fact the control channel is independent on the dynamic pressure.

As for appropriate basic surface finish the external parts are zinc coated.

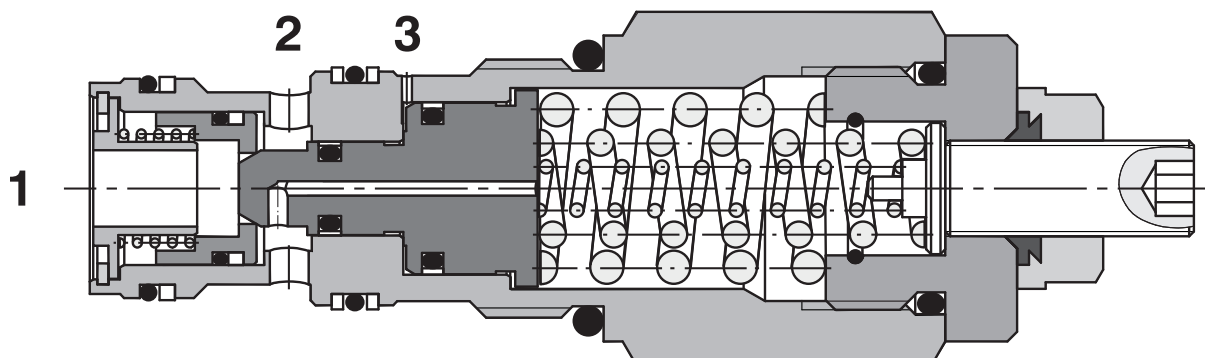

Ordering Code

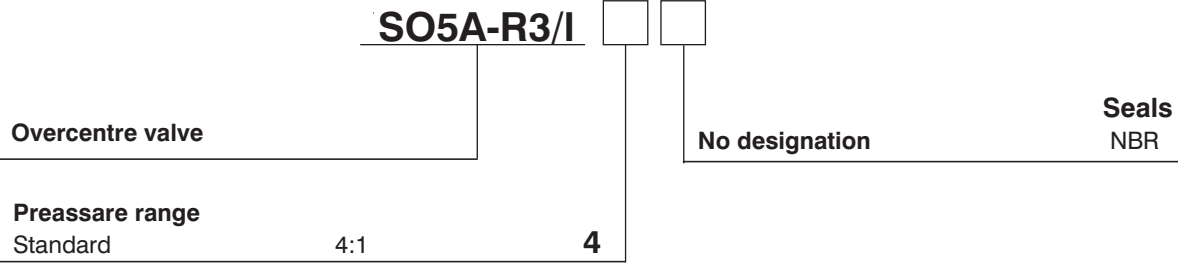

Technical Data

Cavity		M27 x 1,5
Maximum flow	L/min	90
Max. pressure	bar	270
Max. input pressure	bar	350
Pressure drops	bar	see $\Delta p - Q$ characteristics
Hydraulic fluid		Hydraulic oil (HM, HV) according to DIN 51524
Fluid temperature range	°C	-20 ... +90
Viscosity	mm ² /s	20 ... 400
Maximum degree of fluid contamination		according to ISO 4406, Class 21/18/15
Weight	kg	0,29
Maximum valve tightening torque in valve body or in control block	Nm	60 ⁺²
Mounting position		Unrestricted

$\Delta p - Q$ Characteristics

Measured at $v = 40 \text{ mm}^2/\text{s}$

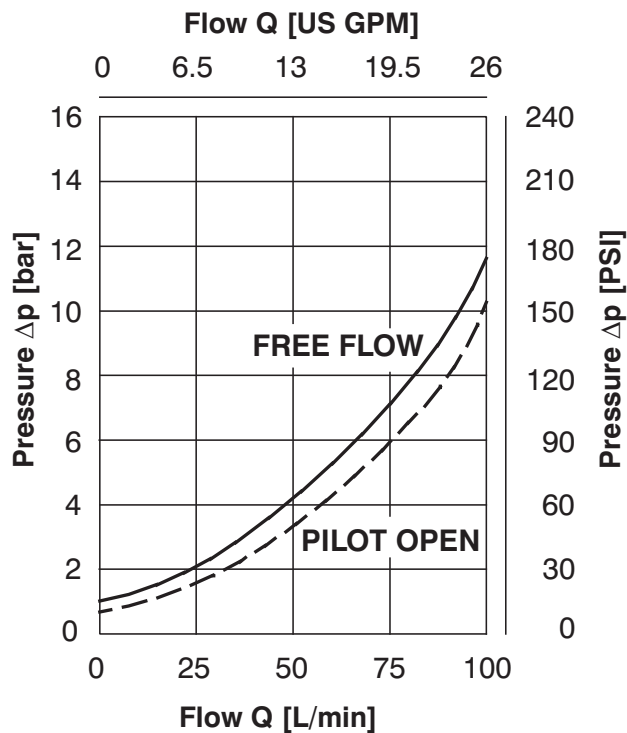

Dimensions

Measurements in millimeters

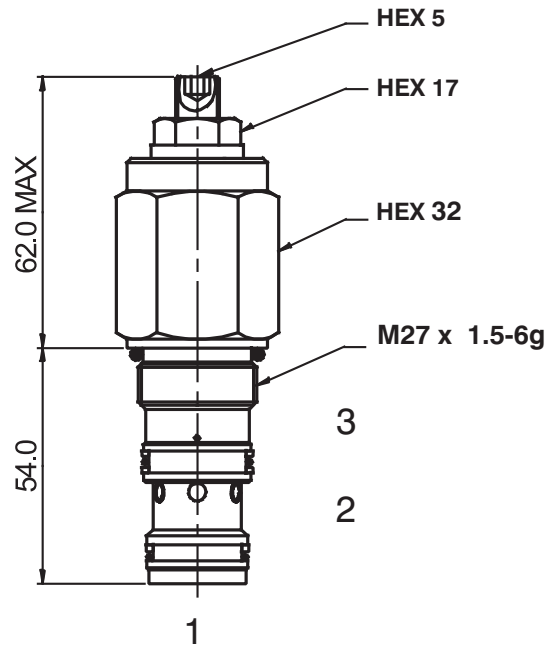

Cavity

Measurements in millimeters

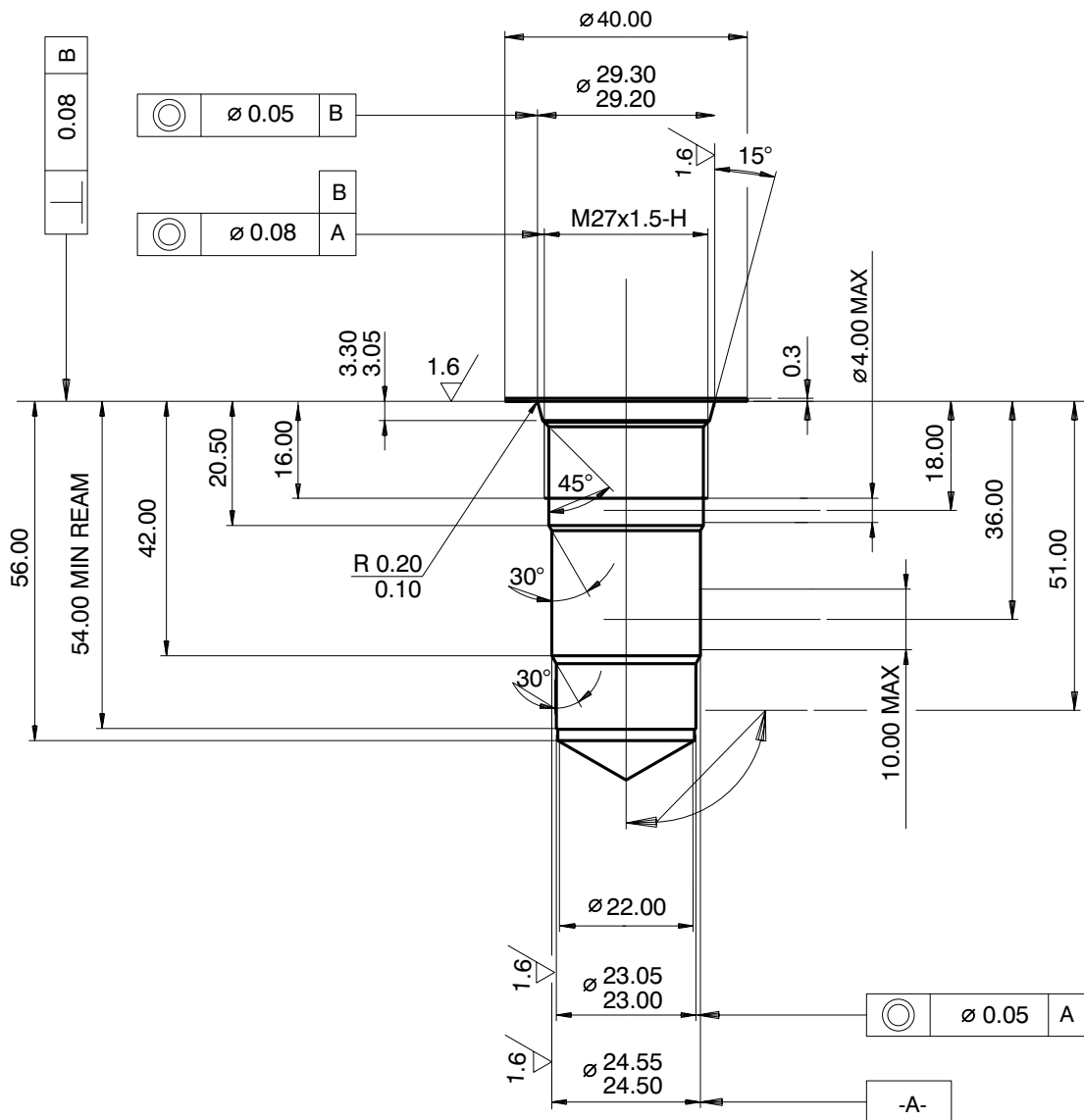

Valve Bodies

Measurements in millimeters

ISO A

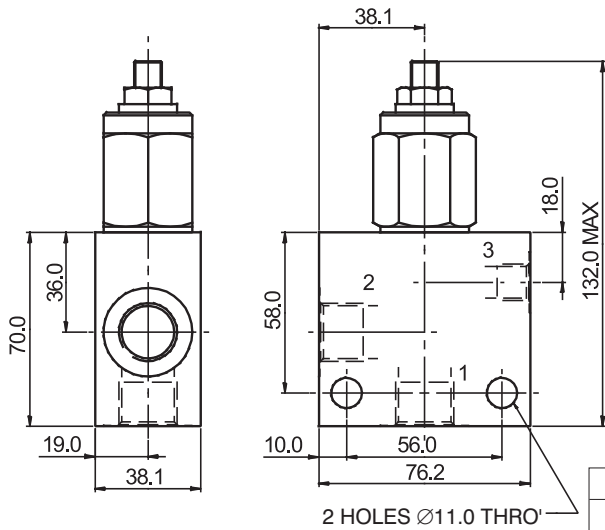
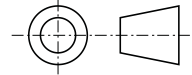

Body without valve			
Material	Ports	Port size	Type code
Aluminium	1, 2	G1/2	SB-R3-0105AL
	3	G1/4	
	1, 2	SAE 10, 7/8-14	SB-R3-0106AL
	3	SAE 6, 9/16-18	
Steel	1, 2	G1/2	SB-R3-0105ST
	3	G1/4	
	1, 2	SAE 10, 7/8-14	SB-R3-0106ST
	3	SAE 6, 9/16-18	

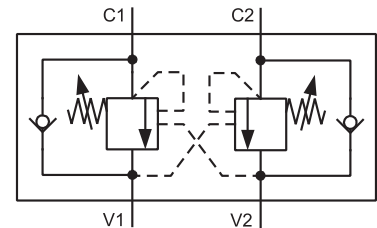
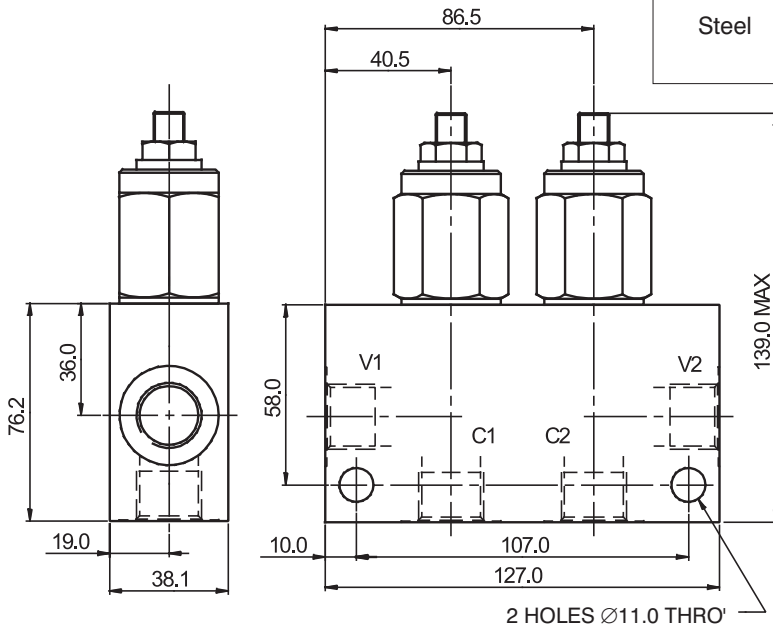

Dual body without valve			
Material	Ports	Port size	Type code
Aluminium	C1, C2, V1, V2	G1/2	SB-R4-0205AL
	C1, C2, V1, V2	SAE 10, 7/8-14	SB-R4-0206AL
Steel	C1, C2, V1, V2	G1/2	SB-R4-0205ST
	C1, C2, V1, V2	SAE 10, 7/8-14	SB-R4-0206ST

The use of aluminium bodies is limited to a maximum operating pressure of 210 bar.

Spare Parts

Seal kits on request.

Caution!

- The packing foil is recyclable.
- The technical information regarding the product presented in this catalogue is for descriptive purposes only. It should not be construed in any case as a guaranteed representation of the product properties in the sense of the law.

ARGO-HYTOS s.r.o. CZ - 543 15 Vrchlaví
 Tel.: +420-499-403111, Fax: +420-499-403421
 E-mail: sales.cz@argo-hytos.com
 www.argo-hytos.com

- The valve prevents runaway in the event of a negative load
- Load-holding with minimal leakage
- Pressure relief function protecting the actuator against overload and pressure peaks
- When installed into the actuator the valve can be used as a hose burst valve
- When used as pressure relief the check valve will act as an anti-cavitation valve
- Relief setting is unaffected by back pressure
- The valve should be mounted as close as possible to the actuator
- Fits the same cavity as the R3 check valve

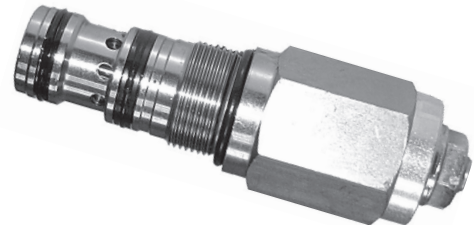
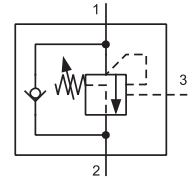

Functional Description

The valve consists of a seat by-pass, relief valve fitted with an auxiliary control with a differential piston and by-pass single-way valve serving for reverse direction of flow. The liquid is flowing through the single-way valve from the channel (2) to the channel (1) with a small pressure drop. In the opposite direction the single-way valve on the rear side of which a gate valve seat is fitted is pressed through the action of a spring and the load pressure against the spring-loaded valve gate valve. In this way the valve is nearly closed hermetically. If the pressure in the channel (1) exceeds a set up value of the spring force the gate valve is pressed out of the seat and the overpressure in that case is relieved into channel (2). For ensuring the function of holding the load the spring force should be set up to a value by 30 % higher when compared to an expected pressure exerted by the load. If the load has to be moved it is possible to ensure it with the help of so called auxiliary control from the channel (3) by introducing already certain control pressure.

The control pressure is calculated in the following way:

$$\text{Control pressure} = \frac{\text{set up pressure} - \text{load pressure}}{\text{ratio of control}}$$

The ratio of control designates a ratio of surfaces of the differential slide valve cross-section area and its seat. Therefore, the necessary control pressure for opening the valve does not correspond to the difference between the set up pressure and load pressure however;

it corresponds to the ratio of this difference and the control ratio. In the formula as mentioned above it is necessary to take into consideration that in differential cylinders it is necessary to add to the control ratio also the appropriate ratio of piston surfaces in the direction of movement.

As soon as the control pressure attains a necessary value the differential gate valve is moved out from the seat and then the way from the channel (1) to the channel (2) is released. If now the load tries to accelerate and be fast as for the oil supply the supply pressure decreases, therefore, also the control pressure in the channel (3) is decreased. The spring force tries to shut off the valve again, therefore, in consequence of which the flow from the consumer decreases and the inlet pressure to the consumer increases again. In this way it is ensured a constant inlet pressure by means of which the movement of the load can be controlled.

Dynamic pressures in the outlet do not influence the set up value thanks to a special arrangement of the slide valve. However, it is necessary to take care of the fact the control channel is independent on the dynamic pressure.

As for appropriate basic surface finish the external parts are zinc coated.

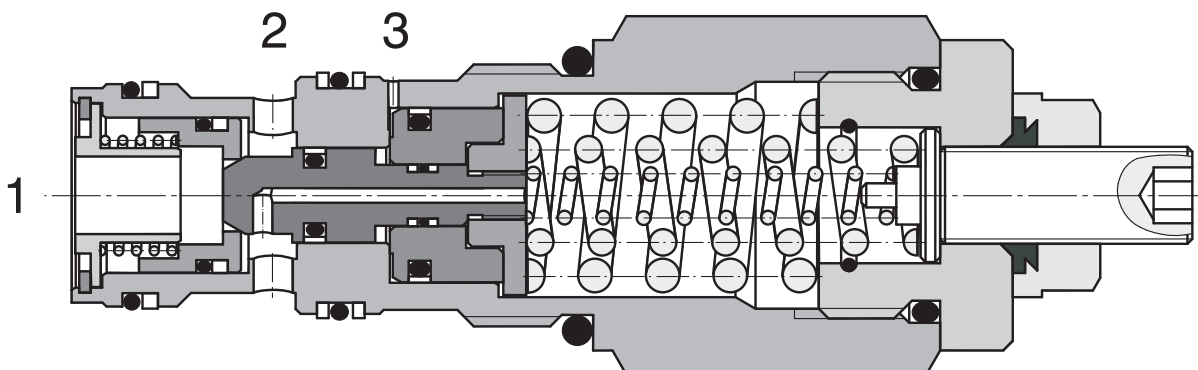

Ordering Code

SOP5A-R3/I

Overcentre valve
Part Balanced

No designation

Seals
NBR

Pressure range
Standard 4:1

4

Technical Data

Cavity		M27 x 1,5
Maximum flow	L/min	90
Max. pressure	bar	270
Max. input pressure	bar	350
Pressure drops	bar	see Δp - Q characteristics
Hydraulic fluid		Hydraulic oil (HM, HV) according to DIN 51524
Fluid temperature range	°C	-20 ... +90
Viscosity	mm ² /s	20 ... 400
Maximum degree of fluid contamination		according to ISO 4406, Class 21/18/15
Weight	kg	0,29
Maximum valve tightening torque in valve body or in control block	Nm	60 ⁺²
Mounting position		Unrestricted

Δp -Q Characteristics

Measured at $v = 40 \text{ mm}^2/\text{s}$

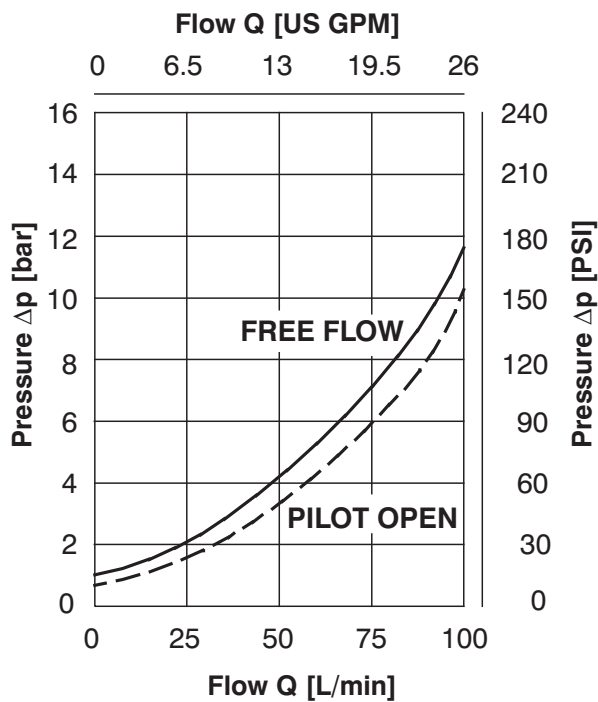

Dimensions

Measurements in millimeters

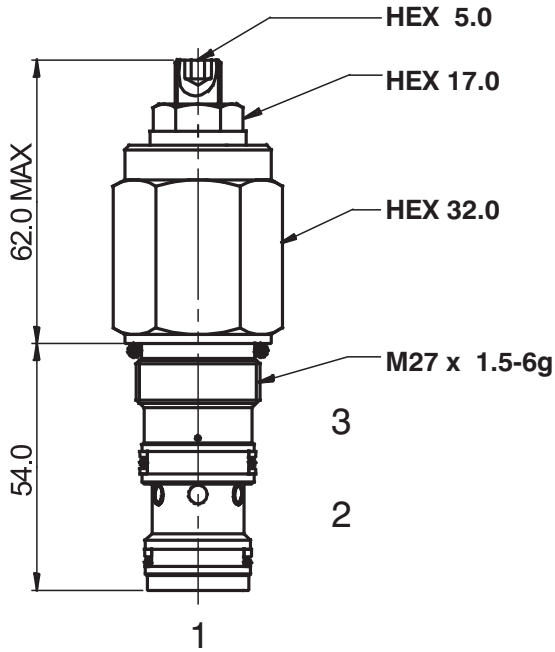

Cavity

Measurements in millimeters

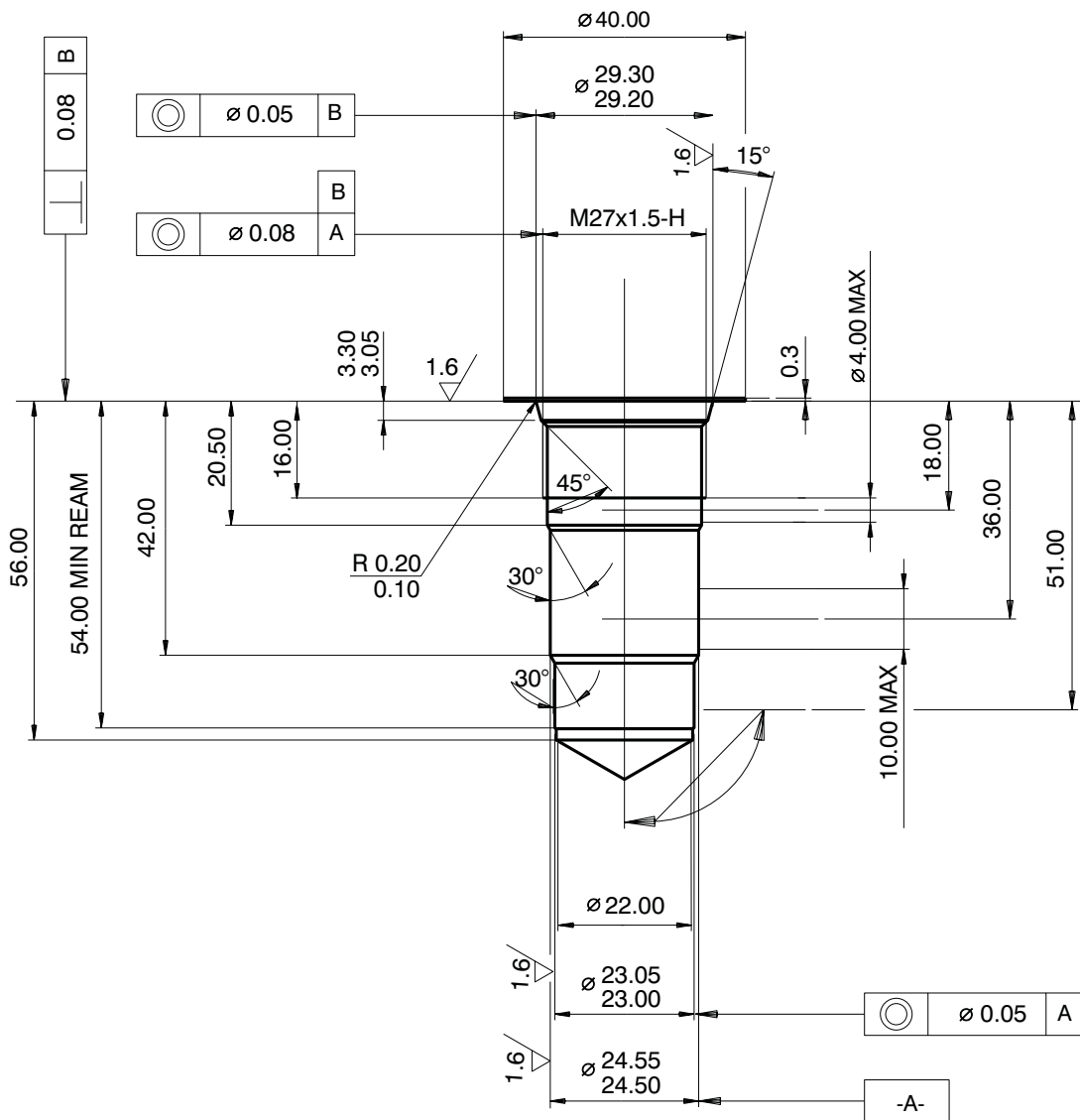

5

Valve Bodies

Measurements in millimeters

ISO A

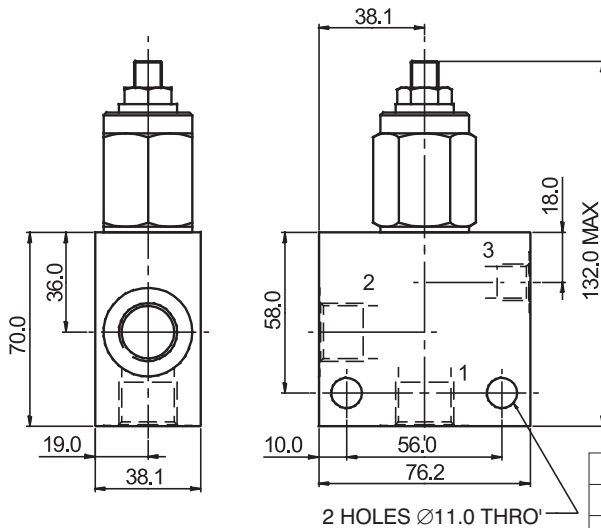
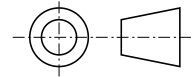

2 HOLES Ø11.0 THRO'

Body without valve			
Material	Ports	Port size	Type code
Aluminium	1, 2	G1/2	SB-R3-0105AL
	3	G1/4	
	1, 2	SAE 10, 7/8-14	SB-R3-0106AL
	3	SAE 6, 9/16-18	
Steel	1, 2	G1/2	SB-R3-0105ST
	3	G1/4	
	1, 2	SAE 10, 7/8-14	SB-R3-0106ST
	3	SAE 6, 9/16-18	

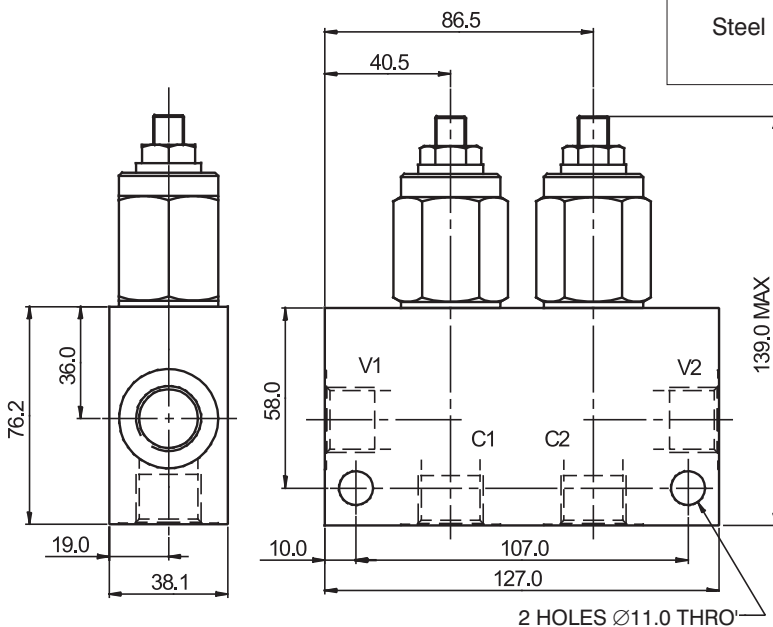

2 HOLES Ø11.0 THRO'

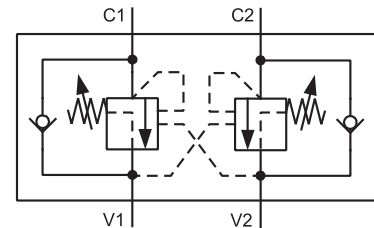

Dual body without valve			
Material	Ports	Port size	Type code
Aluminium	C1, C2, V1, V2	G1/2	SB-R4-0205AL
	C1, C2, V1, V2	SAE 10, 7/8-14	SB-R4-0206AL
Steel	C1, C2, V1, V2	G1/2	SB-R4-0205ST
	C1, C2, V1, V2	SAE 10, 7/8-14	SB-R4-0206ST

The use of aluminium bodies is limited to a maximum operating pressure of 210 bar.

Spare Parts

Seal kits on request.

Caution!

- The packing foil is recyclable.
- The technical information regarding the product presented in this catalogue is for descriptive purposes only. It should not be construed in any case as a guaranteed representation of the product properties in the sense of the law.

ARGO-HYTOS s.r.o. CZ - 543 15 Vrchlaví
 Tel.: +420-499-403111, Fax: +420-499-403421
 E-mail: sales.cz@argo-hytos.com
 www.argo-hytos.com

- The valve prevents runaway in the event of a negative load
- Load-holding with minimal leakage
- Pressure relief function protecting the actuator against overload and pressure peaks
- When installed into the actuator the valve can be used as a hose burst valve
- When used as pressure relief the check valve will act as an anti-cavitation valve
- The valve should be mounted as close as possible to the actuator
- Fits the same cavity as the R3 check valve

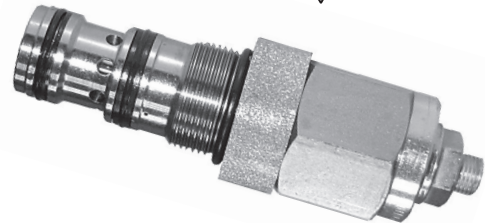
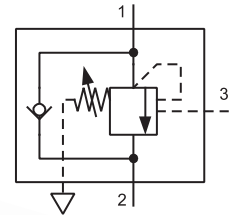

Functional Description

The valve consists of a seat by-pass, relief valve fitted with an auxiliary control with a differential piston and by-pass single-way valve serving for reverse direction of flow. The liquid is flowing through the single-way valve from the channel (2) to the channel (1) with a small pressure drop. In the opposite direction the single-way valve on the rear side of which a gate valve seat is fitted is pressed through the action of a spring and the load pressure against the spring-loaded valve gate valve. In this way the valve is nearly closed hermetically. If the pressure in the channel (1) exceeds a set up value of the spring force the gate valve is pressed out of the seat and the overpressure in that case is relieved into channel (2). For ensuring the function of holding the load the spring force should be set up to a value by 30 % higher when compared to an expected pressure exerted by the load. If the load has to be moved it is possible to ensure it with the help of so called auxiliary control from the channel (3) by introducing already certain control pressure.

The control pressure is calculated in the following way:

$$\text{Control pressure} = \frac{\text{set up pressure} - \text{load pressure}}{\text{ratio of control}}$$

The ratio of control designates a ratio of surfaces of the differential slide valve cross-section area and its seat. Therefore, the necessary control pressure for opening the valve does not correspond to the difference between the set up pressure and load pressure however;

it corresponds to the ratio of this difference and the control ratio. In the formula as mentioned above it is necessary to take into consideration that in differential cylinders it is necessary to add to the control ratio also the appropriate ratio of piston surfaces in the direction of movement.

As soon as the control pressure attains a necessary value the differential gate valve is moved out from the seat and then the way from the channel (1) to the channel (2) is released. If now the load tries to accelerate and be fast as for the oil supply the supply pressure decreases, therefore, also the control pressure in the channel (3) is decreased. The spring force tries to shut off the valve again, therefore, in consequence of which the flow from the consumer decreases and the inlet pressure to the consumer increases again. In this way it is ensured a constant inlet pressure by means of which the movement of the load can be controlled.

Dynamic pressures in the outlet do not influence the set up value thanks to a special arrangement of the slide valve. However, it is necessary to take care of the fact the control channel is independent on the dynamic pressure.

As for appropriate basic surface finish the external parts are zinc coated.

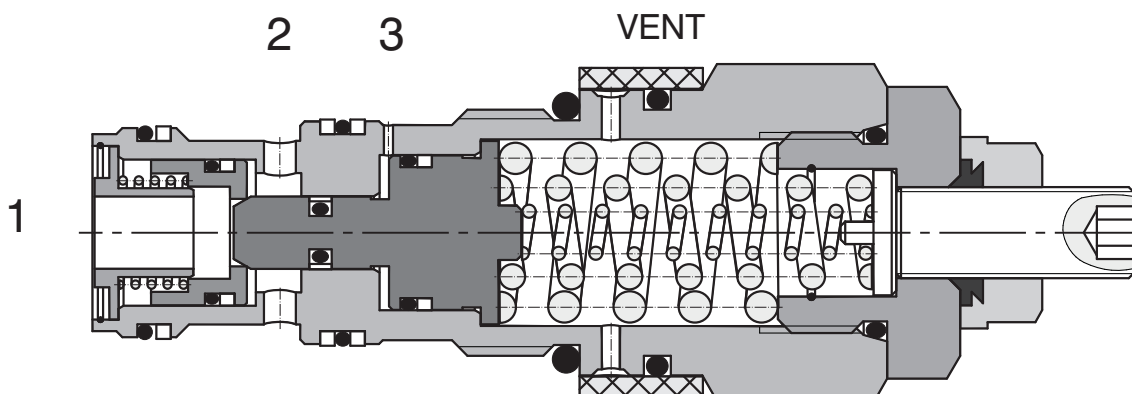

Ordering Code

SOB5A-R3/I

Overcentre valve
Fully Balanced

No designation

Seals
NBR

Pressure range
Standard 4:1

4

Technical Data

Cavity		M27 x 1,5
Maximum flow	L/min	90
Max. pressure	bar	270
Max. input pressure	bar	350
Pressure drops	bar	see $\Delta p - Q$ characteristics
Hydraulic fluid		Hydraulic oil (HM, HV) according to DIN 51524
Fluid temperature range	°C	-20 ... +90
Viscosity	mm ² /s	20 ... 400
Maximum degree of fluid contamination		according to ISO 4406, Class 21/18/15
Weight	kg	0.29
Maximum valve tightening torque in valve body or in control block	Nm	60 ⁺²
Mounting position		Unrestricted

$\Delta p - Q$ Characteristics

Measured at $v = 40 \text{ mm}^2/\text{s}$

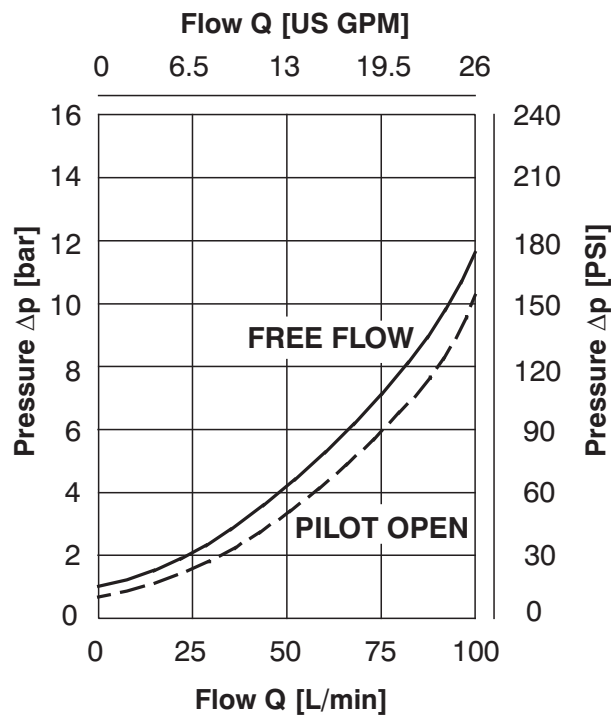

Dimensions

Measurements in millimeters

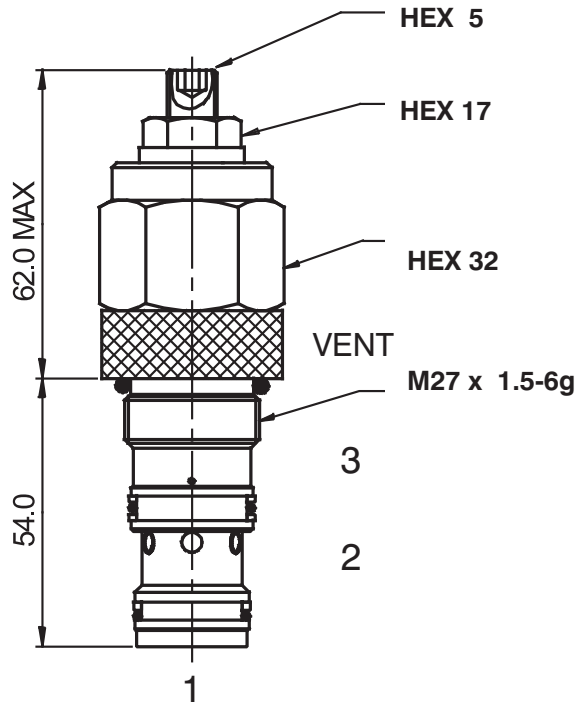

Cavity

Measurements in millimeters

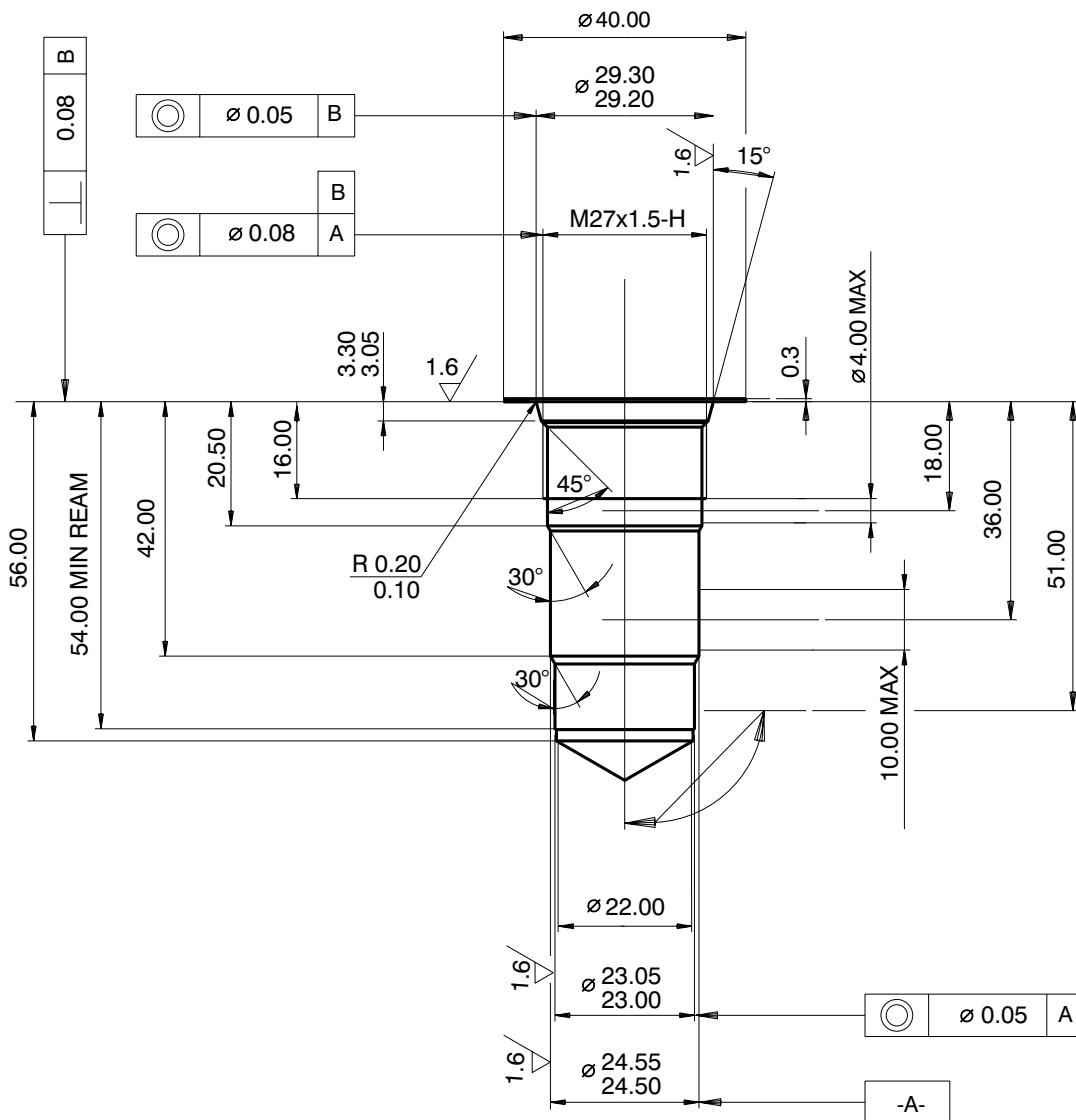

Valve Bodies

Measurements in millimeters

ISO A

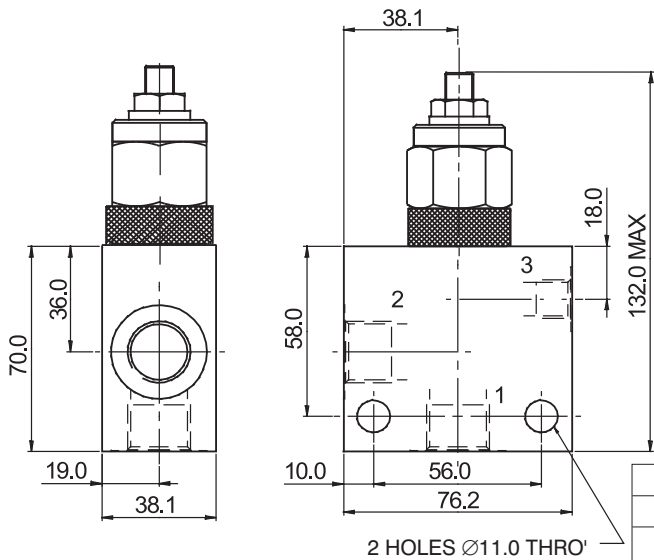
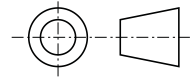

Body without valve			
Material	Ports	Port size	Type code
Aluminium	1, 2	G1/2	SB-R3-0105AL
	3	G1/4	
	1, 2	SAE 10, 7/8-14	SB-R3-0106AL
	3	SAE 6, 9/16-18	
Steel	1, 2	G1/2	SB-R3-0105ST
	3	G1/4	
	1, 2	SAE 10, 7/8-14	SB-R3-0106ST
	3	SAE 6, 9/16-18	

5

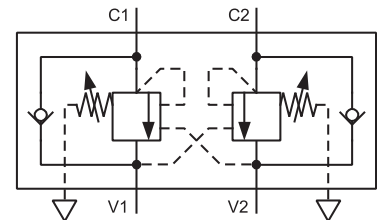
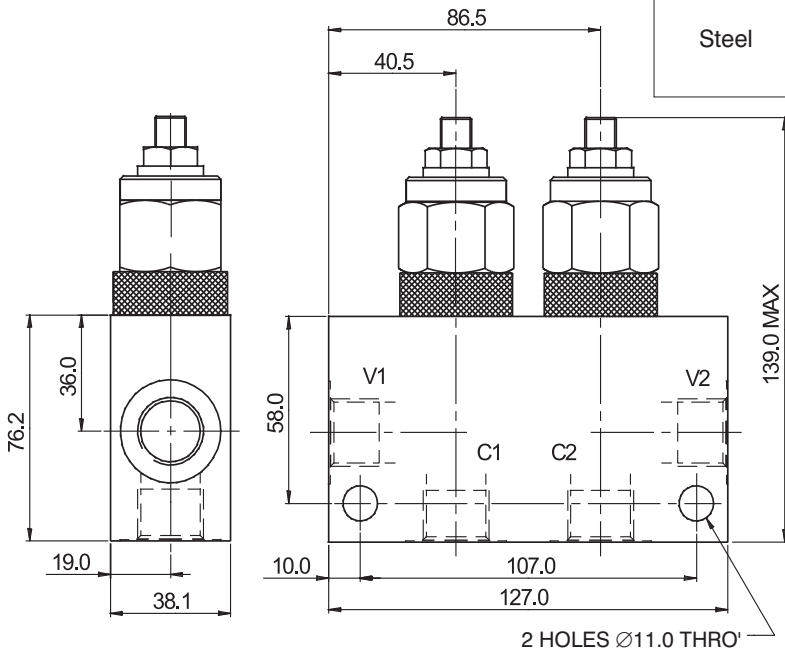

Dual body without valve			
Material	Ports	Port size	Type code
Aluminium	C1, C2, V1, V2	G1/2	SB-R4-0205AL
	C1, C2, V1, V2	SAE 10, 7/8-14	SB-R4-0206AL
Steel	C1, C2, V1, V2	G1/2	SB-R4-0205ST
	C1, C2, V1, V2	SAE 10, 7/8-14	SB-R4-0206ST

The use of aluminium bodies is limited to a maximum operating pressure of 210 bar.

Spare Parts

Seal kits on request.

Caution!

- The packing foil is recyclable.
- The technical information regarding the product presented in this catalogue is for descriptive purposes only. It should not be construed in any case as a guaranteed representation of the product properties in the sense of the law.

ARGO-HYTOS s.r.o. CZ - 543 15 Vrchlaví
 Tel.: +420-499-403111, Fax: +420-499-403421
 E-mail: sales.cz@argo-hytos.com
 www.argo-hytos.com

- The valve prevents runaway in the event of a negative load
- Load-holding with minimal leakage
- Pressure relief function protecting the actuator against overload and pressure peaks
- When installed into the actuator the valve can be used as a hose burst valve
- When used as pressure relief the check valve will act as an anti-cavitation valve
- Relief setting is unaffected by back pressure
- The valve should be mounted as close as possible to the actuator

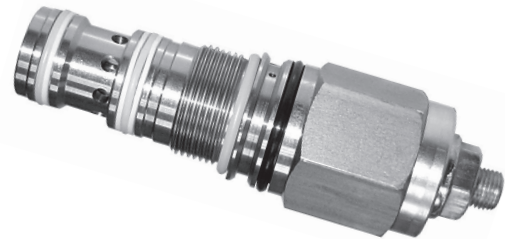
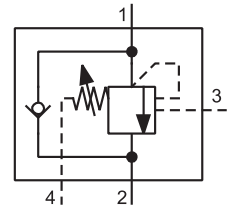

Functional Description

The valve consists of a seat by-pass, relief valve fitted with an auxiliary control with a differential piston and by-pass single-way valve serving for reverse direction of flow. The liquid is flowing through the single-way valve from the channel (2) to the channel (1) with a small pressure drop. In the opposite direction the single-way valve on the rear side of which a gate valve seat is fitted is pressed through the action of a spring and the load pressure against the spring-loaded valve gate valve. In this way the valve is nearly closed hermetically. If the pressure in the channel (1) exceeds a set up value of the spring force the gate valve is pressed out of the seat and the overpressure in that case is relieved into channel (2). For ensuring the function of holding the load the spring force should be set up to a value by 30 % higher when compared to an expected pressure exerted by the load. If the load has to be moved it is possible to ensure it with the help of so called auxiliary control from the channel (3) by introducing already certain control pressure.

The control pressure is calculated in the following way:

$$\text{Control pressure} = \frac{\text{set up pressure} - \text{load pressure}}{\text{ratio of control}}$$

The ratio of control designates a ratio of surfaces of the differential slide valve cross-section area and its seat. Therefore, the necessary control pressure for opening the valve does not correspond to the difference between

the set up pressure and load pressure however; it corresponds to the ratio of this difference and the control ratio. In the formula as mentioned above it is necessary to take into consideration that in differential cylinders it is necessary to add to the control ratio also the appropriate ratio of piston surfaces in the direction of movement.

As soon as the control pressure attains a necessary value the differential gate valve is moved out from the seat and then the way from the channel (1) to the channel (2) is released. If now the load tries to accelerate and be fast as for the oil supply the supply pressure decreases, therefore, also the control pressure in the channel (3) is decreased. The spring force tries to shut off the valve again, therefore, in consequence of which the flow from the consumer decreases and the inlet pressure to the consumer increases again. In this way it is ensured a constant inlet pressure by means of which the movement of the load can be controlled.

Dynamic pressures in the outlet do not influence the set up value thanks to a special arrangement of the slide valve. However, it is necessary to take care of the fact the control channel is independent on the dynamic pressure.

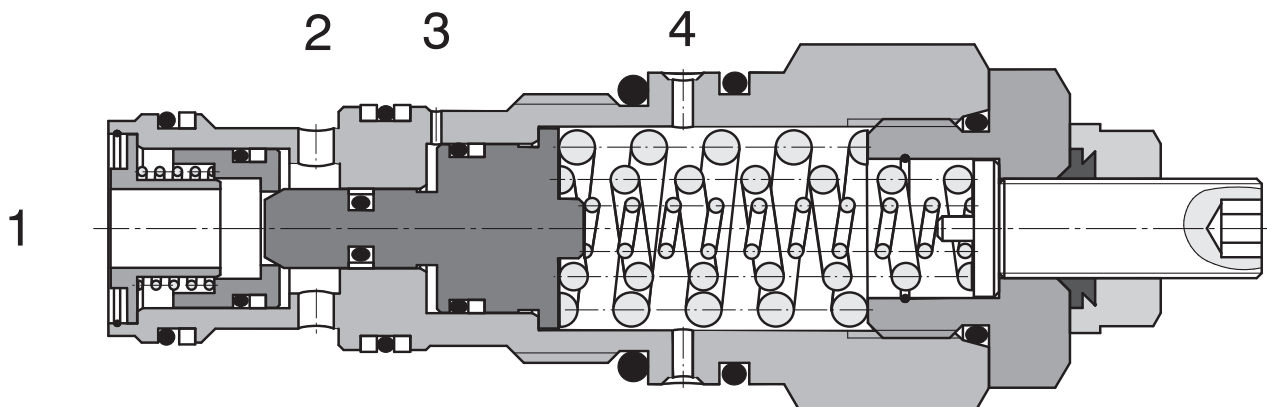

Ordering Code

SOBD5A-R4/I

Overcentre valve
Fully Balanced

No designation

Seals
NBR

Pressure range
Standard 4:1

4

Technical Data

Cavity		M27 x 1,5
Maximum flow	L/min	90
Max. pressure	bar	270
Max. input pressure	bar	350
Pressure drops	bar	see $\Delta p - Q$ characteristics
Hydraulic fluid		Hydraulic oil (HM, HV) according to DIN 51524
Fluid temperature range	°C	-20 ... +90
Viscosity	mm ² /s	20 ... 400
Maximum degree of fluid contamination		according to ISO 4406, Class 21/18/15
Weight	kg	0,29
Maximum valve tightening torque in valve body or in control block	Nm	60 ⁺²
Mounting position		Unrestricted

$\Delta p - Q$ Characteristics

Measured at $v = 40 \text{ mm}^2/\text{s}$

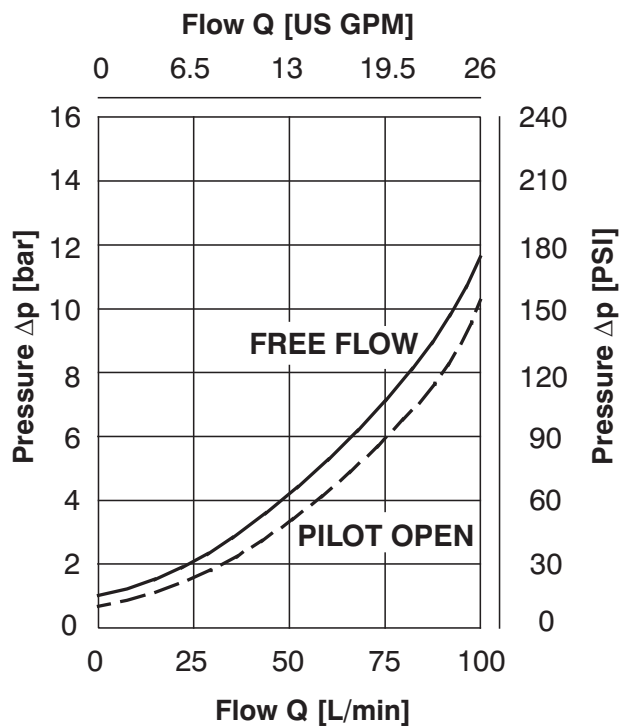

Dimensions

Measurements in millimeters

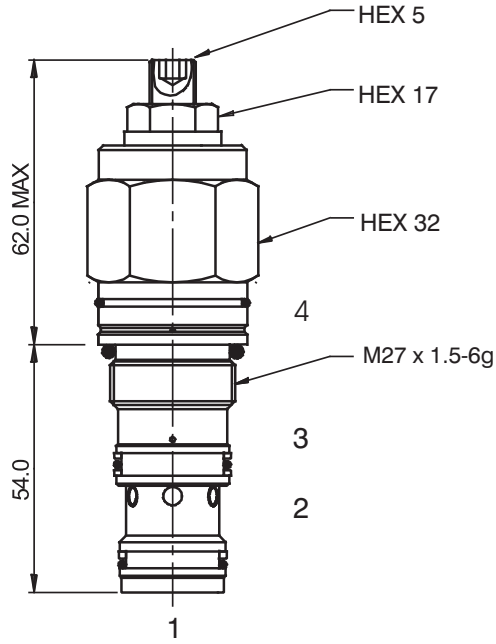

Cavity

Measurements in millimeters

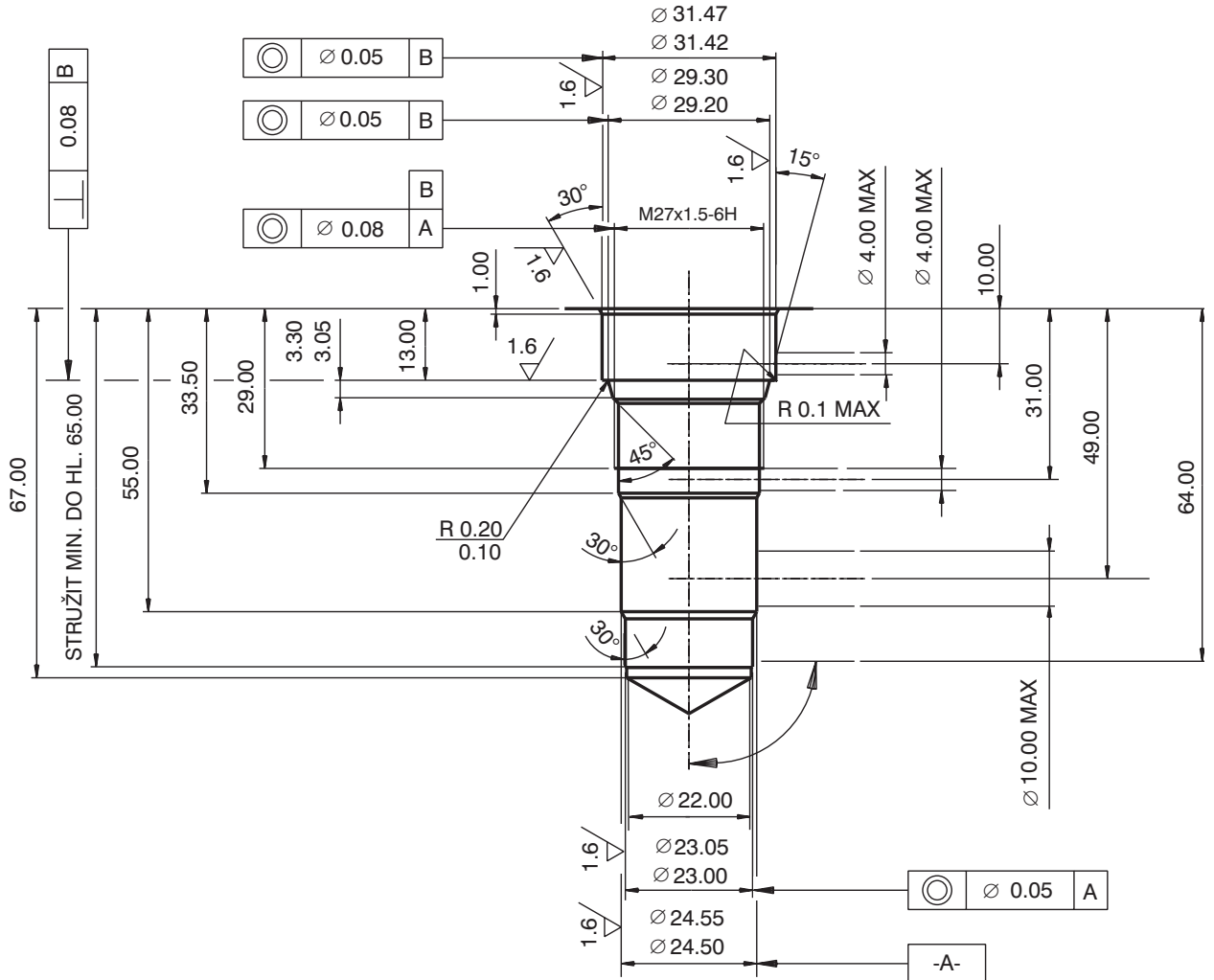

5

Spare Parts

Seal kits on request.

Caution!

- The packing foil is recyclable.
- The technical information regarding the product presented in this catalogue is for descriptive purposes only. It should not be construed in any case as a guaranteed representation of the product properties in the sense of the law.

ARGO-HYTOS s.r.o. CZ - 543 15 Vrchlabí
Tel.: +420-499-403 111
E-mail: info.cz@argo-hytos.com
www.argo-hytos.com

- The valve prevents runaway in the event of a negative load
- Smooth and continuous motion by maintaining a constant back pressure
- Load-holding with minimal leakage
- When installed into the actuator the valve can be used as a hose burst valve
- The valve should be mounted as close as possible to the actuator

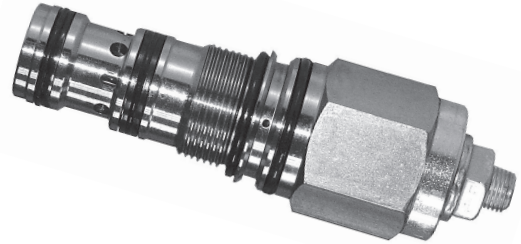
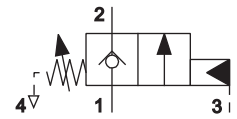

Functional Description

The valve consists of a seat relief valve fitted with an auxiliary control and by-pass single-way valve serving for reverse direction of flow. The liquid is flowing through the single-way valve from the channel (2) to the channel (1) with a small pressure drop. In the opposite direction the single-way valve on the rear side of which a gate valve seat is fitted is pressed through the action of a spring and the load pressure against the spring-loaded valve gate valve. In this way the valve is nearly closed hermetically. For ensuring the function of holding the load the spring force should be set up to a value by 30 % higher when compared to an expected pressure exerted by the load. If a load pressure caused by the action of the force on the consumer or in consequence of the liquid thermal dilatation exceeds a set up value of the spring force the gate valve is pressed out of the seat and the overpressure in that case is relieved from channel (1) to channel (2).

If the load has to be moved in opposite direction from the other connection of the consumer being in that case under pressure it is possible to ensure it with the help of so called auxiliary control from the channel (3) by introducing already certain control pressure.

The necessary control pressure for opening the valve corresponds to the difference between the set up pressure and load pressure. In the formula as mentioned above it is necessary to take into consideration that in differential cylinders it is necessary to take into consideration the relation of surfaces of the cylinder piston in the direction of movement.

As soon as the control pressure attains a necessary value the gate valve is moved out from the seat and then the way from the channel (1) to the channel (2) is released.

If now the load tries to accelerate and be fast as for the oil supply the supply pressure decreases, therefore, also the control pressure in the channel (3) is reduced. The spring force tries to shut off the valve again, therefore, in consequence of which the supply flow to the consumer is reduced and the inlet pressure increases again. In this way it is ensured a constant inlet pressure by means of which it would be possible to control the movement of the load.

As for appropriate basic surface finish the external parts are zinc coated.

The control pressure is calculated in the following way:
Control pressure = set up pressure – load pressure.

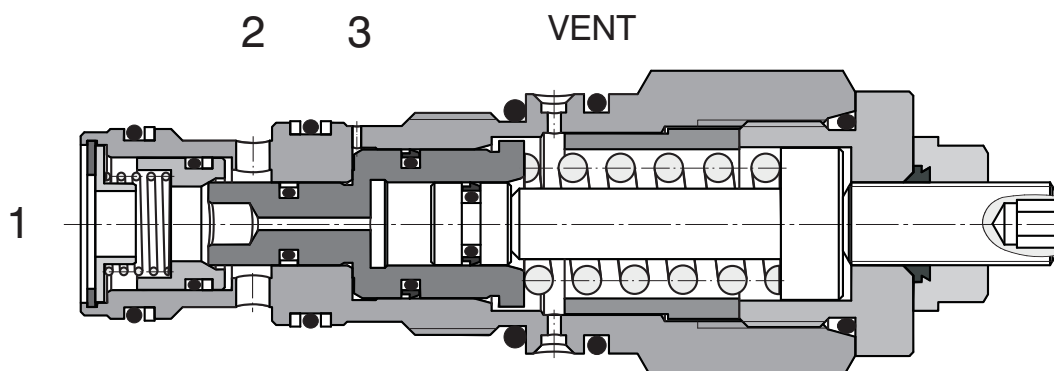

Ordering Code

SOZD5A-R4/I

Overcentre valve
Zero Differential

No designation

Seals
NBR

Pressure range
5 - 20 bar

2

Factory setting 10 bar for Q=4.8 L/min

Technical Data

Cavity		M27 x 1.5
Maximum flow	L/min	90
Max. pressure	bar	350
Max. input pressure	bar	5 - 20
Pressure drops	bar	see Δp - Q characteristics
Hydraulic fluid		Hydraulic oil (HM, HV) according to DIN 51524
Fluid temperature range	°C	-20 ... +90
Viscosity	mm ² /s	20 ... 400
Maximum degree of fluid contamination		according to ISO 4406, Class 21/18/15
Weight	kg	0,29
Maximum valve tightening torque in valve body or in control block	Nm	60 ⁺²
Mounting position		Unrestricted

Δp -Q Characteristics

Measured at $v = 40 \text{ mm}^2/\text{s}$

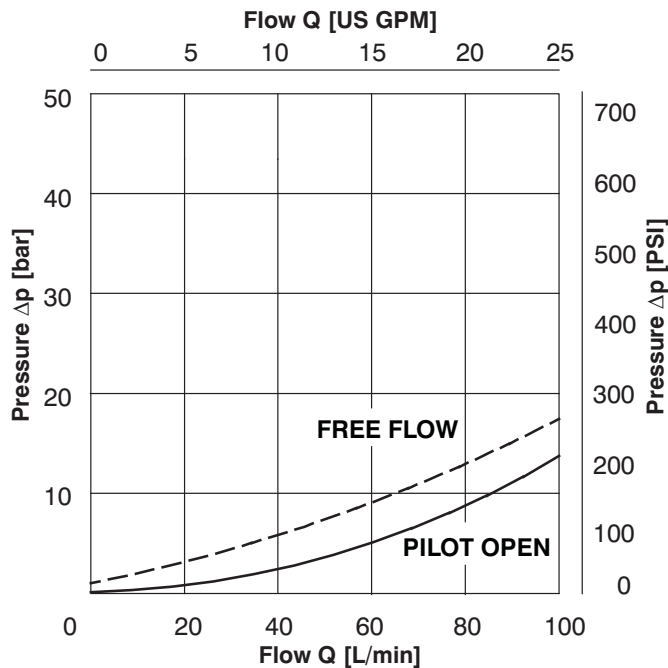

Dimensions

Measurements in millimeters

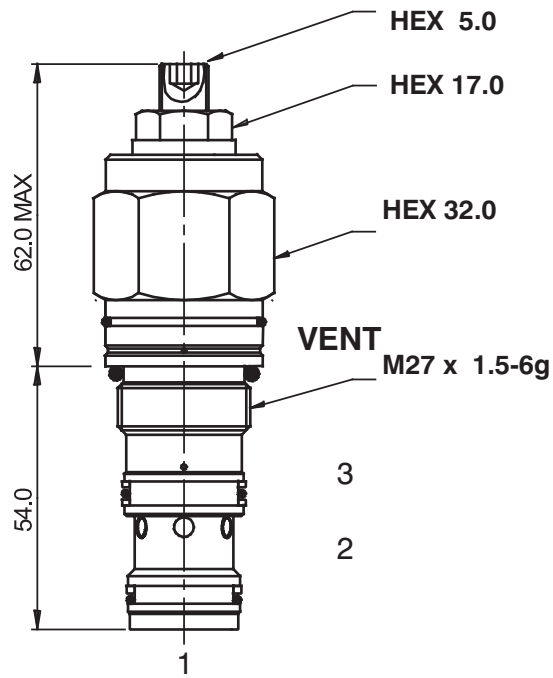

Cavity

Measurements in millimeters

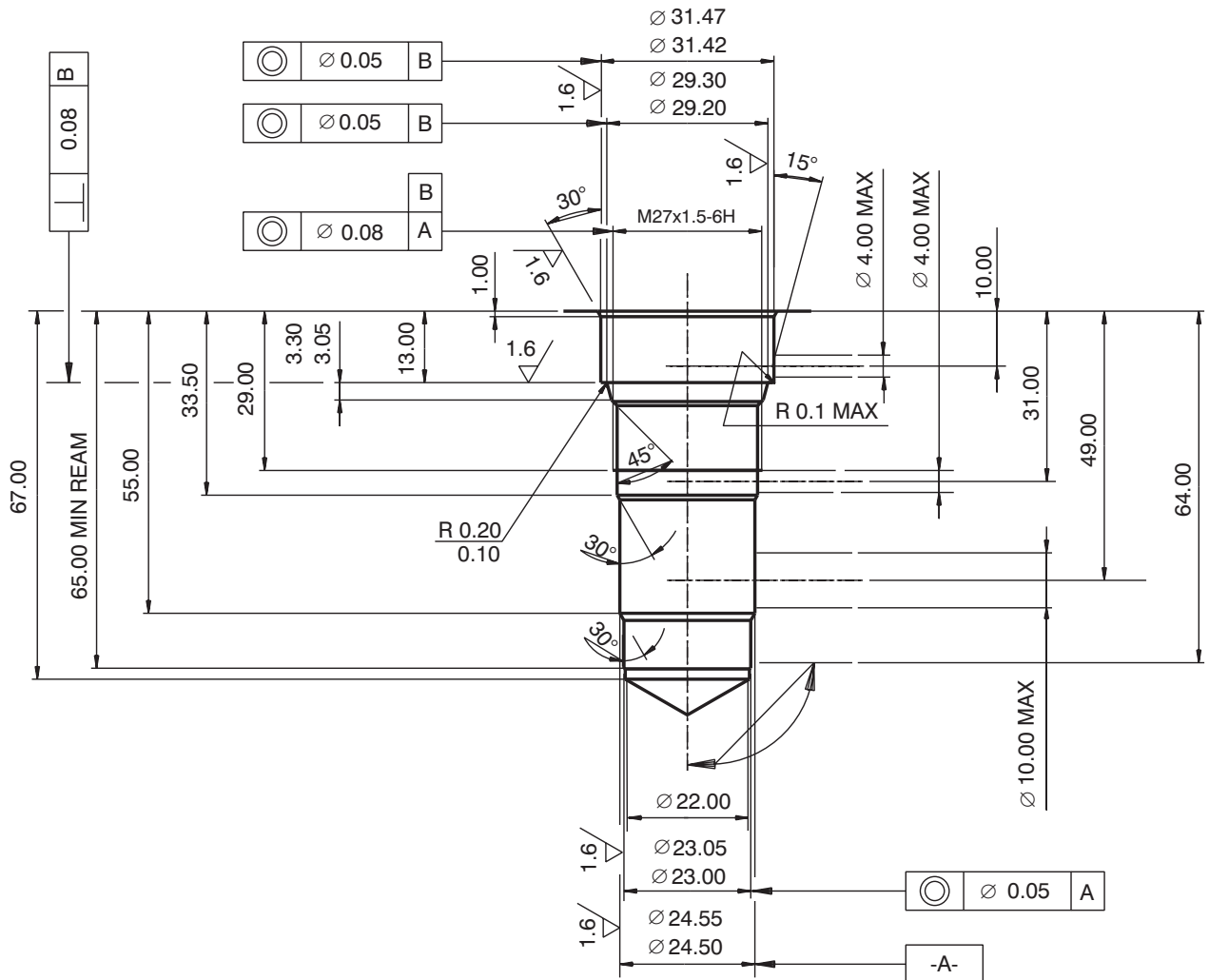

5

Spare Parts

Seal kits on request.

Caution!

- The packing foil is recyclable.
- The technical information regarding the product presented in this catalogue is for descriptive purposes only. It should not be construed in any case as a guaranteed representation of the product properties in the sense of the law.

ARGO-HYTOS s.r.o. CZ - 543 15 Vrchlabí
Tel.: +420-499-403111, Fax: +420-499-403421
E-mail: sales.cz@argo-hytos.com
www.argo-hytos.com

- The valve prevents runaway in the event of a negative load
- Load-holding without leakage
- With pressure relief function protecting the actuator against overload and pressure peaks
- When installed into the actuator the valve can be used as a hose burst valve
- When used as pressure relief the check valve will act as an anti-cavitation valve
- Relief setting is unaffected by back pressure
- The valve should be mounted as close as possible to the actuator
- Fits the same cavity as the S3 check valve

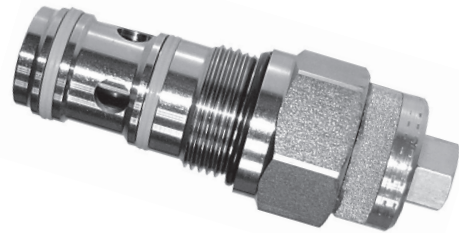
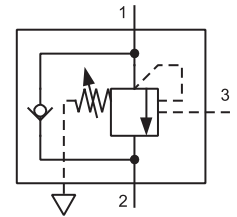

Functional Description

The valve consists of a seat by-pass, relief valve fitted with an auxiliary control with a differential piston and by-pass single-way valve serving for reverse direction of flow. The liquid is flowing through the single-way valve from the channel (2) to the channel (1) with a small pressure drop. In the opposite direction the single-way valve on the rear side of which a gate valve seat is fitted is pressed through the action of a spring and the load pressure against the spring-loaded valve gate valve. In this way the valve is nearly closed hermetically. If the pressure in the channel (1) exceeds a set up value of the spring force the gate valve is pressed out of the seat and the overpressure in that case is relieved into channel (2). For ensuring the function of holding the load the spring force should be set up to a value by 30 % higher when compared to an expected pressure exerted by the load. If the load has to be moved it is possible to ensure it with the help of so called auxiliary control from the channel (3) by introducing already certain control pressure.

The control pressure is calculated in the following way:

$$\text{Control pressure} = \frac{\text{set up pressure} - \text{load pressure}}{\text{ratio of control}}$$

The ratio of control designates a ratio of surfaces of the differential slide valve cross-section area and its seat. Therefore, the necessary control pressure for opening the valve does not correspond to the difference between the set up pressure and load pressure however;

it corresponds to the ratio of this difference and the control ratio. In the formula as mentioned above it is necessary to take into consideration that in differential cylinders it is necessary to add to the control ratio also the appropriate ratio of piston surfaces in the direction of movement.

As soon as the control pressure attains a necessary value the differential gate valve is moved out from the seat and then the way from the channel (1) to the channel (2) is released. If now the load tries to accelerate and be fast as for the oil supply the supply pressure decreases, therefore, also the control pressure in the channel (3) is decreased. The spring force tries to shut off the valve again, therefore, in consequence of which the flow from the consumer decreases and the inlet pressure to the consumer increases again. In this way it is ensured a constant inlet pressure by means of which the movement of the load can be controlled.

Dynamic pressures in the outlet do not influence the set up value thanks to a special arrangement of the slide valve. However, it is necessary to take care of the fact the control channel is independent on the dynamic pressure.

As for appropriate basic surface finish the external parts are zinc coated.

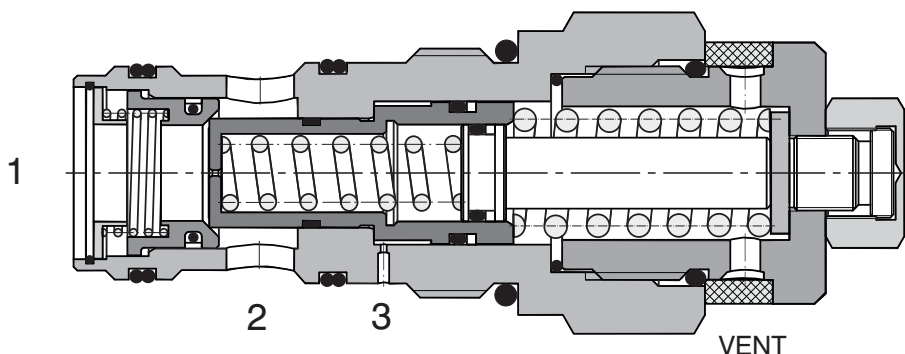

Ordering Code

SOB5A-S3/I

Overcentre valve
Fully Balanced

Seals
NBR

No designation

Preassare range
Standard 3:1 **3**

Technical Data

Cavity		1-5/16-12 UN-2A
Maximum flow	L/min	120
Max. pressure	bar	270
Max. input pressure	bar	350
Pressure drops	bar	see $\Delta p - Q$ characteristics
Hydraulic fluid		Hydraulic oil (HM, HV) according to DIN 51524
Fluid temperature range	°C	-20 ... +90
Viscosity	mm ² /s	20 ... 400
Maximum degree of fluid contamination		according to ISO 4406, Class 21/18/15
Weight	kg	0,59
Maximum valve tightening torque in valve body or in control block	Nm	100 ⁺²
Mounting position		unrestricted

$\Delta p - Q$ Characteristics

Measured at $v = 40 \text{ mm}^2/\text{s}$

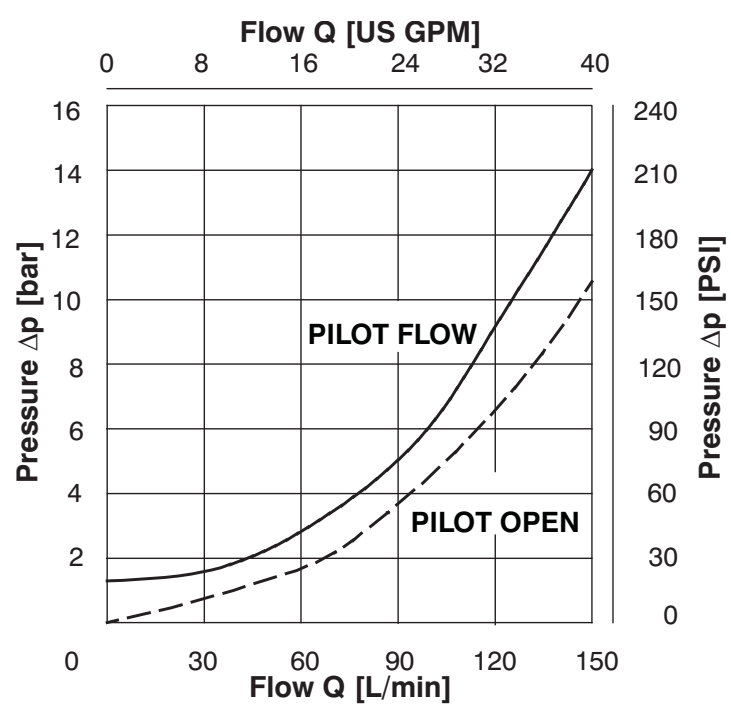

5

Dimensions

Measurements in millimeters

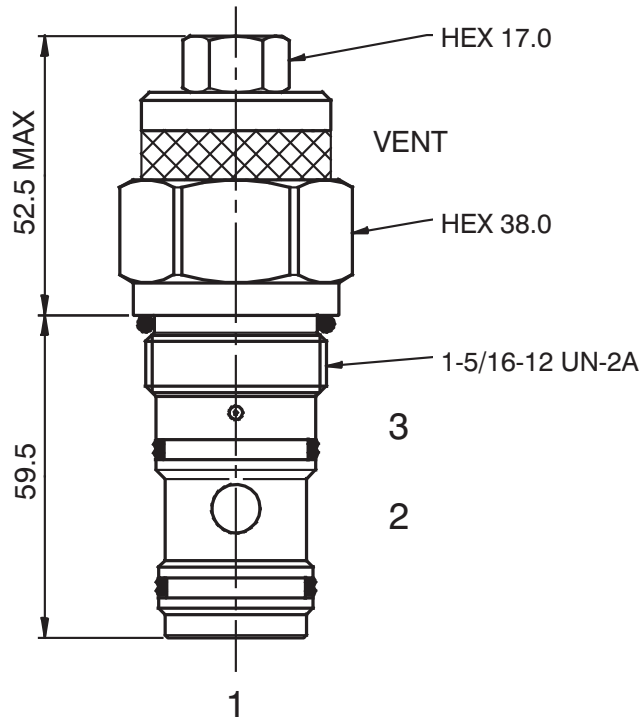

Cavity

Measurements in millimeters

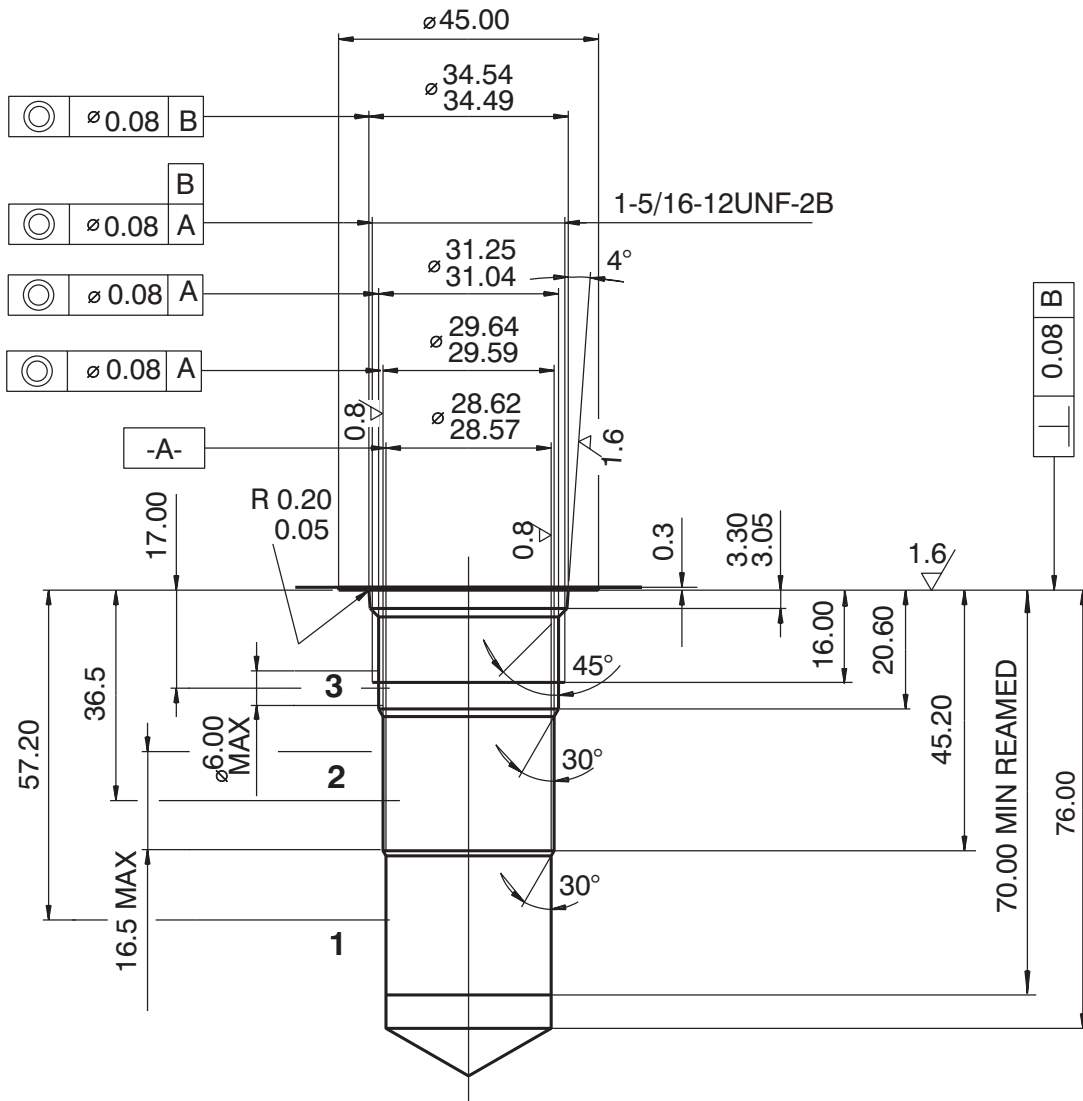

5

Valve Bodies

Measurements in millimeters

ISO A

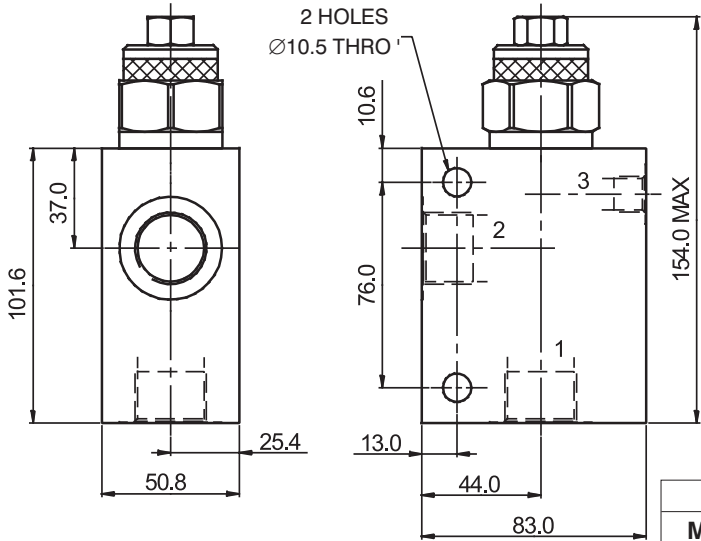
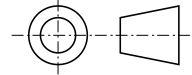

Body without valve			
Material	Ports	Port size	Type code
Aluminium	1, 2	G3/4	SB-S3-0107AL
	3	G1/4	
	1, 2	SAE 12,1-1/16-12	SB-S3-0108AL
	3	SAE 6, 9/16-18	
Steel	1, 2	G3/4	SB-S3-0107ST
	3	G1/4	
	1, 2	SAE 12,1-1/16-12	SB-S3-0108ST
	3	SAE 6, 9/16-18	

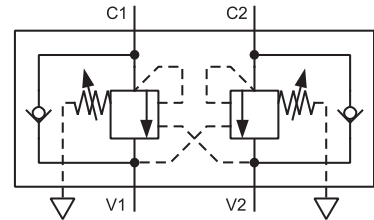
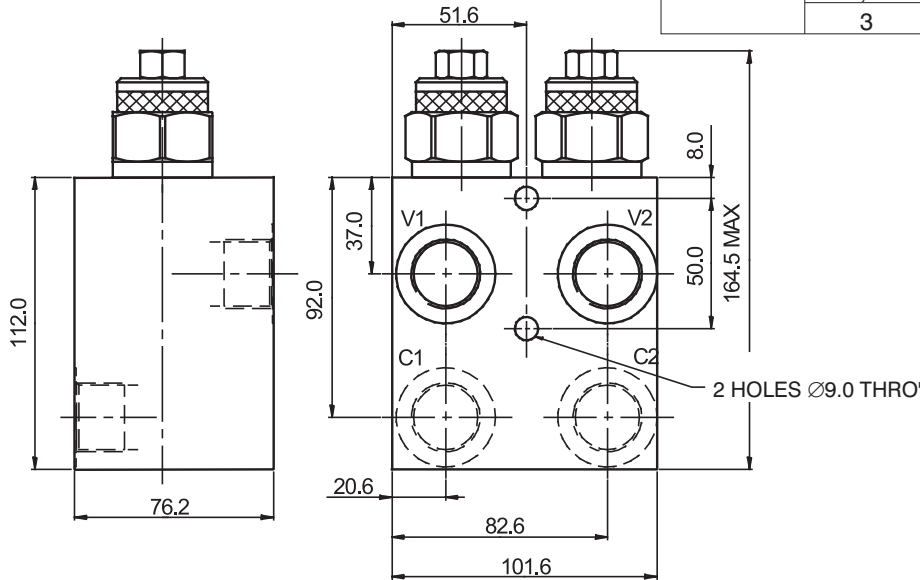

Dual body without valve			
Material	Ports	Port size	Type code
Aluminium	C1, C2, V1, V2	G3/4	SB-S4-0207AL
	C1, C2, V1, V2	SAE 12,1-1/16-12	SB-S4-0208AL
Steel	C1, C2, V1, V2	G3/4	SB-S4-0207ST
	C1, C2, V1, V2	SAE 12,1-1/16-12	SB-S4-0208ST

The use of aluminium bodies is limited to a maximum operating pressure of 210 bar.

Spare Parts

Seal kits on request.

Caution!

- The packing foil is recyclable.
- The technical information regarding the product presented in this catalogue is for descriptive purposes only. It should not be construed in any case as a guaranteed representation of the product properties in the sense of the law.

ARGO-HYTOS s.r.o. CZ - 543 15 Vrchlaví
 Tel.: +420-499-403111, Fax: +420-499-403421
 E-mail: sales.cz@argo-hytos.com
 www.argo-hytos.com

- The valve prevents runaway in the event of a negative load
- Load-holding without leakage
- Pressure relief function protecting the actuator against overload and pressure peaks
- When installed into the actuator the valve can be used as a hose burst valve
- When used as pressure relief the check valve will act as an anti-cavitation valve
- Relief setting is unaffected by back pressure
- The valve should be mounted as close as possible to the actuator

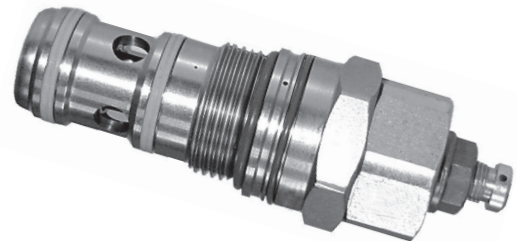
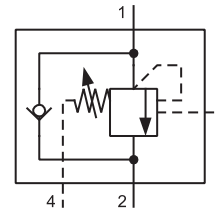

Functional Description

The valve consists of a seat by-pass, relief valve fitted with an auxiliary control with a differential piston and by-pass single-way valve serving for reverse direction of flow. The liquid is flowing through the single-way valve from the channel (2) to the channel (1) with a small pressure drop. In the opposite direction the single-way valve on the rear side of which a gate valve seat is fitted is pressed through the action of a spring and the load pressure against the spring-loaded valve gate valve. In this way the valve is nearly closed hermetically. If the pressure in the channel (1) exceeds a set up value of the spring force the gate valve is pressed out of the seat and the overpressure in that case is relieved into channel (2). For ensuring the function of holding the load the spring force should be set up to a value by 30 % higher when compared to an expected pressure exerted by the load. If the load has to be moved it is possible to ensure it with the help of so called auxiliary control from the channel (3) by introducing already certain control pressure.

The control pressure is calculated in the following way:

$$\text{Control pressure} = \frac{\text{set up pressure} - \text{load pressure}}{\text{ratio of control}}$$

The ratio of control designates a ratio of surfaces of the differential slide valve cross-section area and its seat. Therefore, the necessary control pressure for opening the valve does not correspond to the difference between the set up pressure and load pressure however;

it corresponds to the ratio of this difference and the control ratio. In the formula as mentioned above it is necessary to take into consideration that in differential cylinders it is necessary to add to the control ratio also the appropriate ratio of piston surfaces in the direction of movement.

As soon as the control pressure attains a necessary value the differential gate valve is moved out from the seat and then the way from the channel (1) to the channel (2) is released. If now the load tries to accelerate and be fast as for the oil supply the supply pressure decreases, therefore, also the control pressure in the channel (3) is decreased. The spring force tries to shut off the valve again, therefore, in consequence of which the flow from the consumer decreases and the inlet pressure to the consumer increases again. In this way it is ensured a constant inlet pressure by means of which the movement of the load can be controlled.

Dynamic pressures in the outlet do not influence the set up value thanks to a special arrangement of the slide valve. However, it is necessary to take care of the fact the control channel is independent on the dynamic pressure.

As for appropriate basic surface finish the external parts are zinc coated.

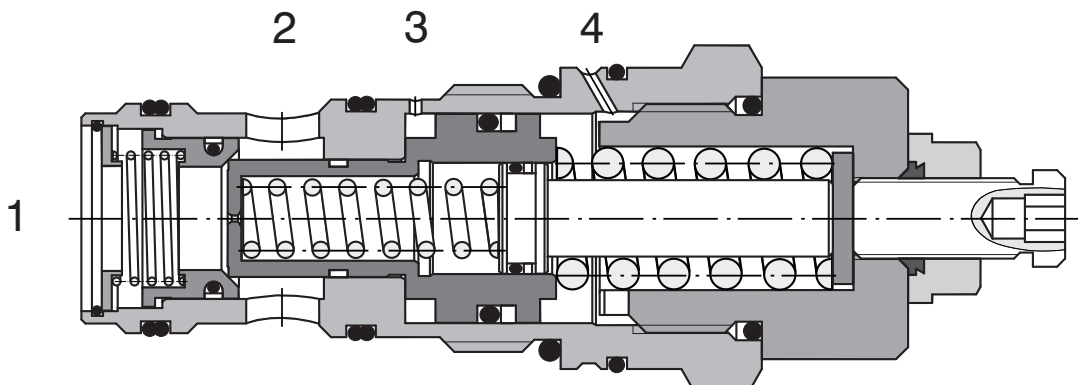

Ordering Code

SOBD5A-S3/I

Overcentre valve
Fully Balanced

No designation

Seals
NBR

Preassare range
Standard 8:1

8

Technical Data

Cavity		1-5/16-12 UN-2A
Maximum flow	L/min	180
Max. pressure	bar	270
Max. input pressure	bar	400
Pressure drops	bar	see Δp - Q characteristics
Hydraulic fluid		Hydraulic oil (HM, HV) according to DIN 51524
Fluid temperature range	°C	-20 ... +90
Viscosity	mm ² /s	20 ... 400
Maximum degree of fluid contamination		according to ISO 4406, Class 21/18/15
Weight	kg	0,59
Maximum valve tightening torque in valve body or in control block	Nm	100 ⁺²
Mounting position		unrestricted

Δp -Q Characteristics

Measured at $v = 40 \text{ mm}^2/\text{s}$

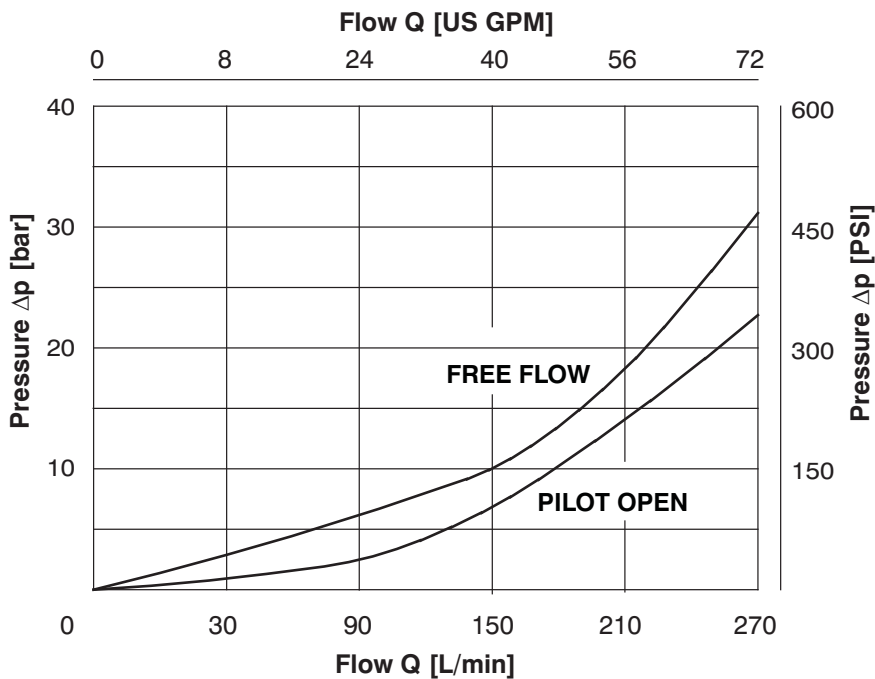

Dimensions

Measurements in millimeters

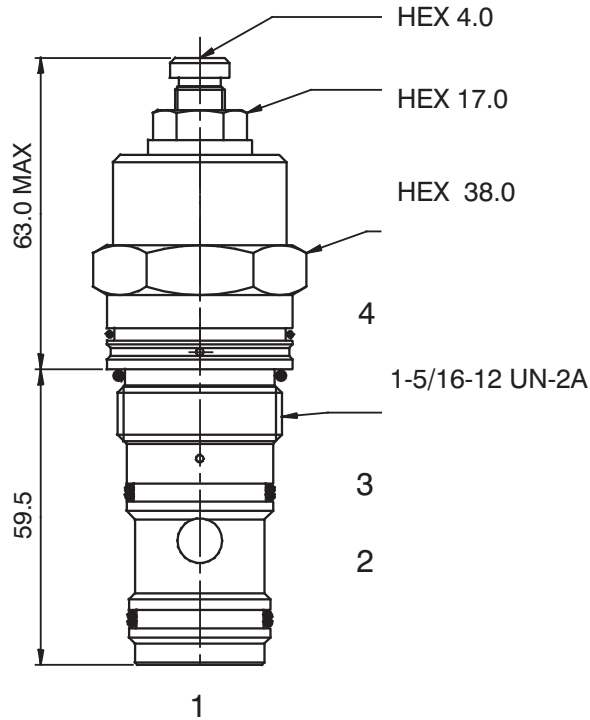

Cavity

Measurements in millimeters

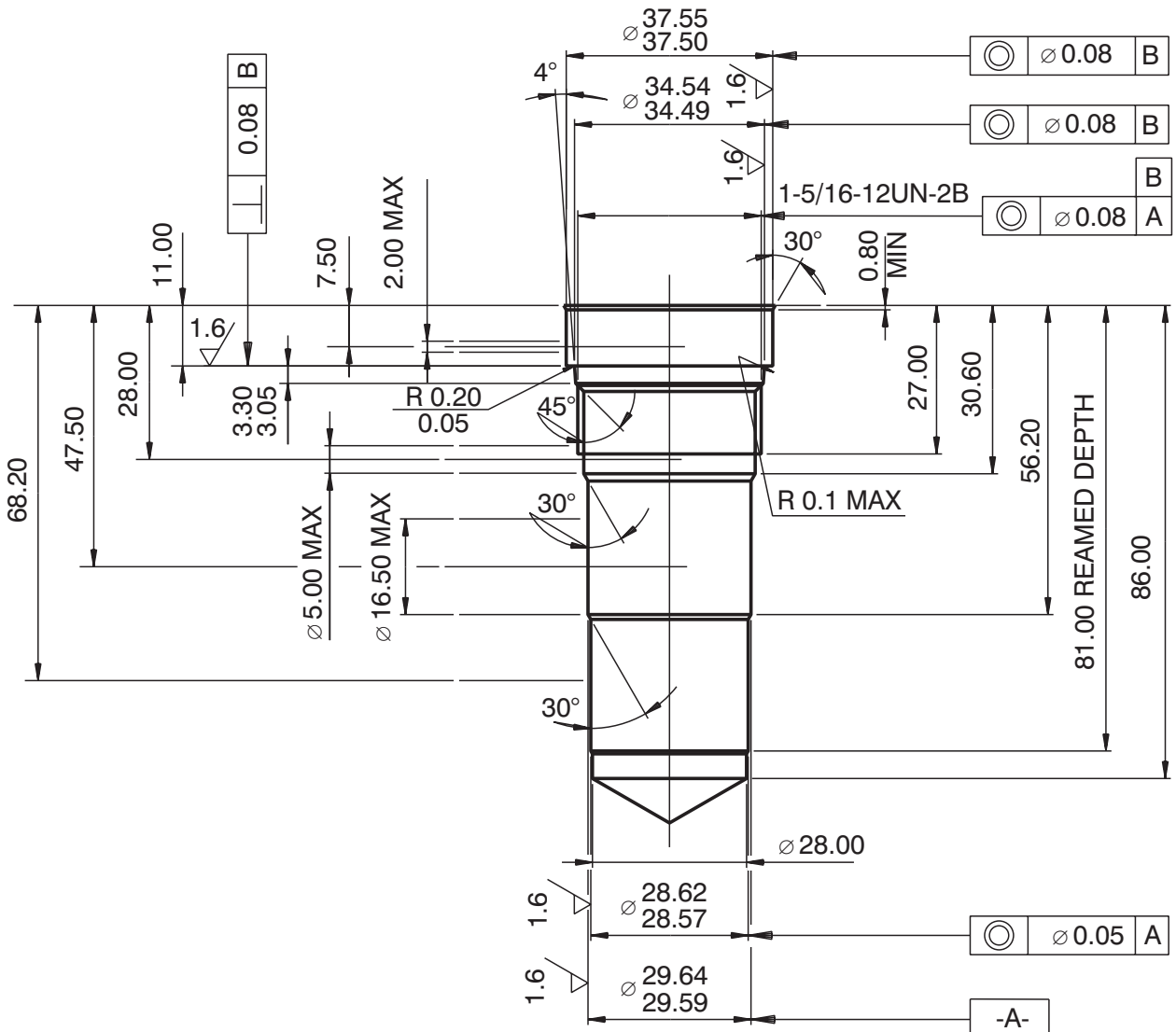

5

Spare Parts

Seal kits on request.

Caution!

- The packing foil is recyclable.
- The technical information regarding the product presented in this catalogue is for descriptive purposes only. It should not be construed in any case as a guaranteed representation of the product properties in the sense of the law.

ARGO-HYTOS s.r.o. CZ - 543 15 Vrchlabí
Tel.: +420-499-403111, Fax: +420-499-403421
E-mail: sales.cz@argo-hytos.com
www.argo-hytos.com

- The valve prevents runaway in the event of a negative load
- Smooth and continuous motion by maintaining a constant back pressure
- Load-holding without leakage
- When installed into the actuator the valve can be used as a hose burst valve
- The valve should be mounted as close as possible to the actuator

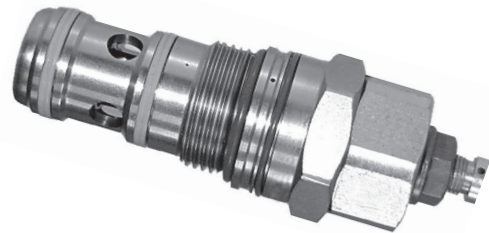
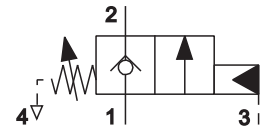

Functional Description

The valve consists of a seat relief valve fitted with an auxiliary control and by-pass single-way valve serving for reverse direction of flow. The liquid is flowing through the single-way valve from the channel (2) to the channel (1) with a small pressure drop. In the opposite direction the single-way valve on the rear side of which a gate valve seat is fitted is pressed through the action of a spring and the load pressure against the spring-loaded valve gate valve. In this way the valve is nearly closed hermetically. For ensuring the function of holding the load the spring force should be set up to a value by 30 % higher when compared to an expected pressure exerted by the load. If a load pressure caused by the action of the force on the consumer or in consequence of the liquid thermal dilatation exceeds a set up value of the spring force the gate valve is pressed out of the seat and the overpressure in that case is relieved from channel (1) to channel (2).

If the load has to be moved in opposite direction from the other connection of the consumer being in that case under pressure it is possible to ensure it with the help of so called auxiliary control from the channel (3) by introducing already certain control pressure.

The control pressure is calculated in the following way:

Control pressure = set up pressure – load pressure

The necessary control pressure for opening the valve corresponds to the difference between the set up pressure and load pressure. In the formula as mentioned above it is necessary to take into consideration that in differential cylinders it is necessary to take into consideration the relation of surfaces of the cylinder piston in the direction of movement.

As soon as the control pressure attains a necessary value the gate valve is moved out from the seat and then the way from the channel (1) to the channel (2) is released.

If now the load tries to accelerate and be fast as for the oil supply the supply pressure decreases, therefore, also the control pressure in the channel (3) is reduced. The spring force tries to shut off the valve again, therefore, in consequence of which the supply flow to the consumer is reduced and the inlet pressure increases again. In this way it is ensured a constant inlet pressure by means of which it would be possible to control the movement of the load.

As for appropriate basic surface finish the external parts are zinc coated..

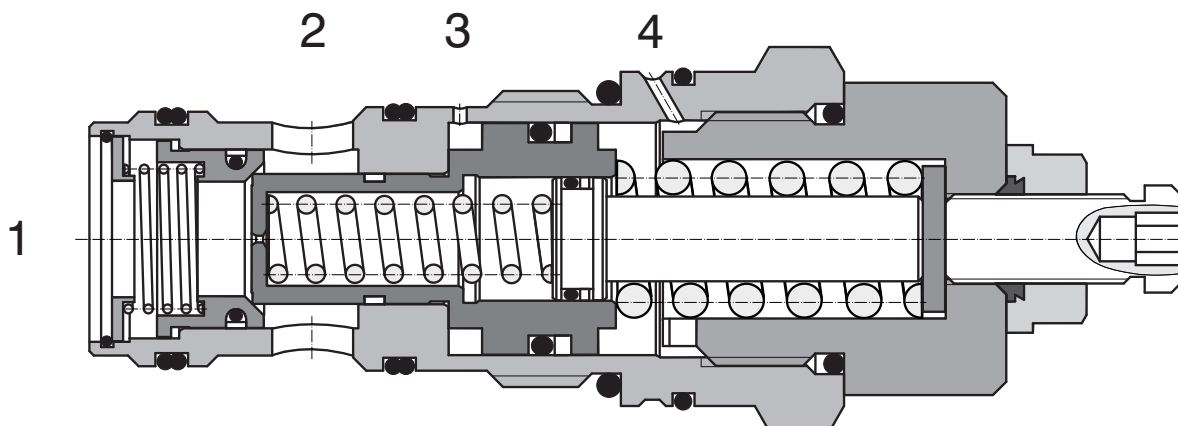

Ordering Code

SOZD5A-S4/I

Overcentre valve
zero differential

No designation

Seals
NBR

Adjustable pressure
5 - 20 bar

2

Factory setting 10 bar for Q=4.8L/min

Technical Data

Cavity		1-5/16-12UN-2A
Maximum flow	L/min	180
Max. pressure	bar	400
Max. input pressure	bar	5-20
Pressure drops	bar	see $\Delta p - Q$ characteristics
Hydraulic fluid		Hydraulic oil (HM, HV) according to DIN 51524
Fluid temperature range	°C	-20 ... +90
Viscosity	mm ² /s	20 ... 400
Maximum degree of fluid contamination		according to ISO 4406, Class 21/18/15
Weight	kg	0,59
Maximum valve tightening torque in valve body or in control block	Nm	100 ⁺²
Mounting position		Unrestricted

$\Delta p - Q$ Characteristics

Measured at $v = 40 \text{ mm}^2/\text{s}$

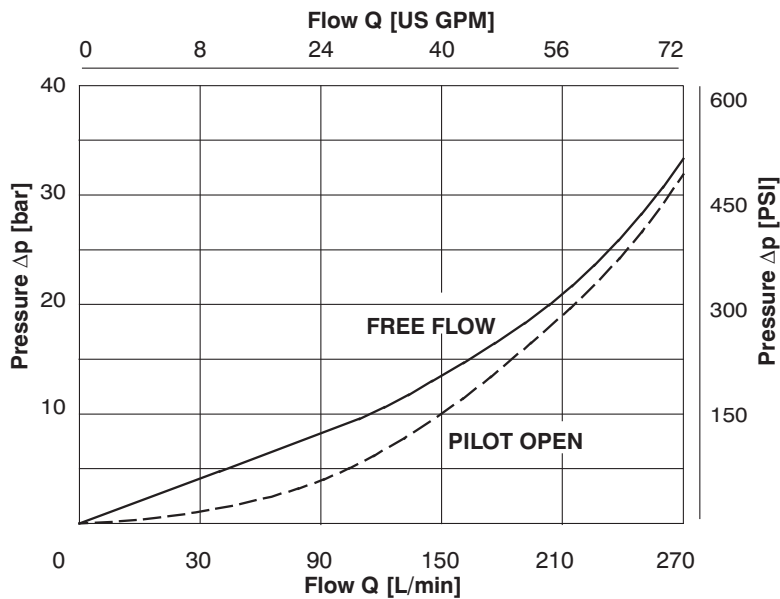

Dimensions

Measurements in millimeters

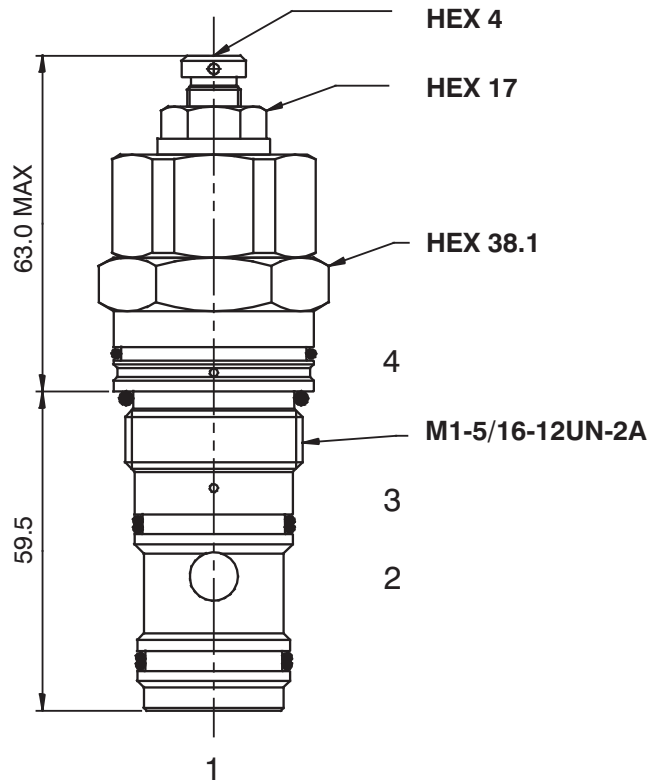

Cavity

Measurements in millimeters

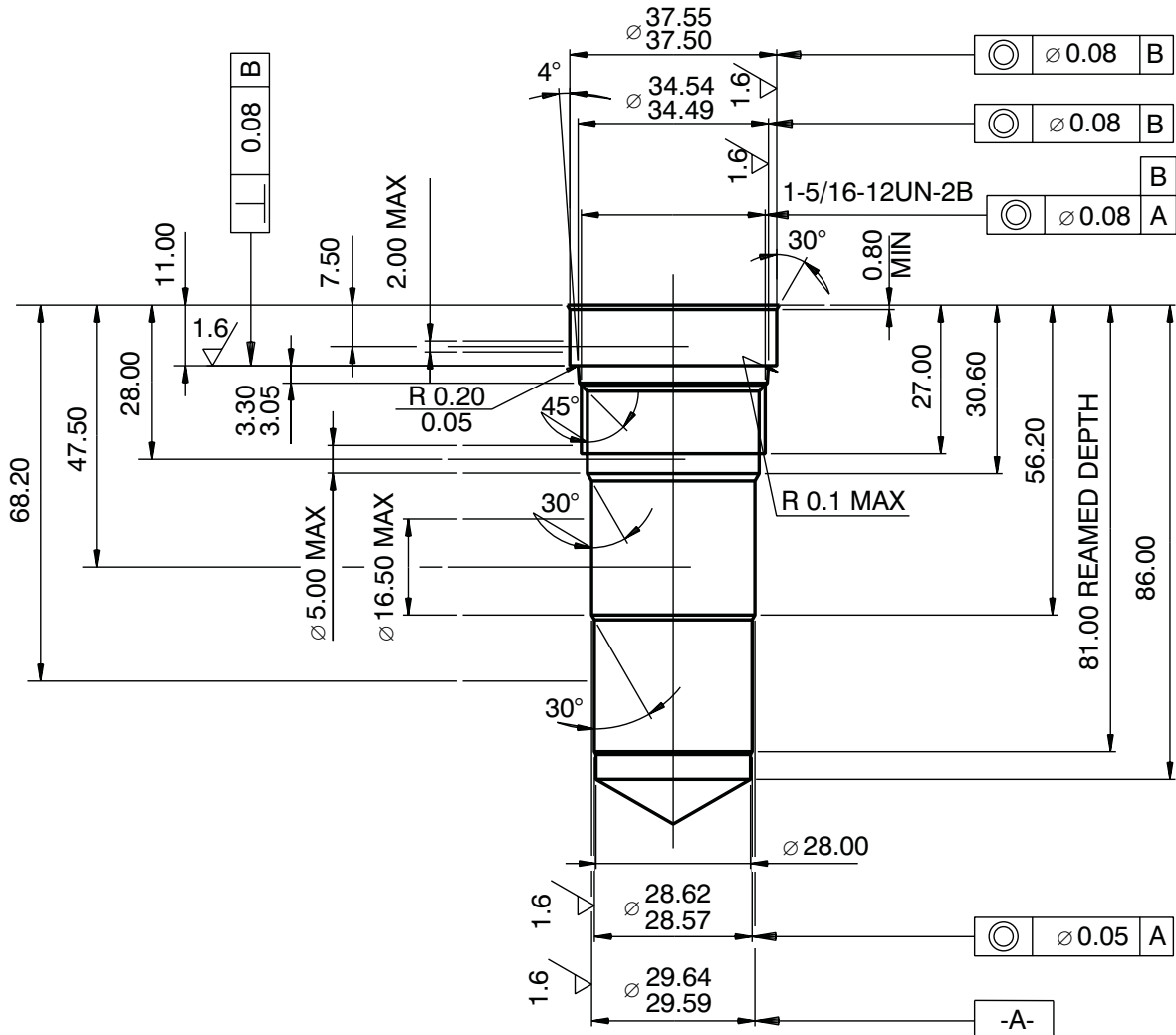

5

Spare Parts

Seal kits on request.

Caution!

- The packing foil is recyclable.
- The technical information regarding the product presented in this catalogue is for descriptive purposes only. It should not be construed in any case as a guaranteed representation of the product properties in the sense of the law.

ARGO-HYTOS s.r.o. CZ - 543 15 Vrchlabí
Tel.: +420-499-403111, Fax: +420-499-403421
E-mail: sales.cz@argo-hytos.com
www.argo-hytos.com

- The valve prevents runaway in the event of a negative load
- Load-holding without leakage
- Pressure relief function protecting the actuator against overload and pressure peaks
- When installed into the actuator the valve can be used as a hose burst valve
- When used as pressure relief the check valve will act as an anti-cavitation valve
- The valve should be mounted as close as possible to the actuator

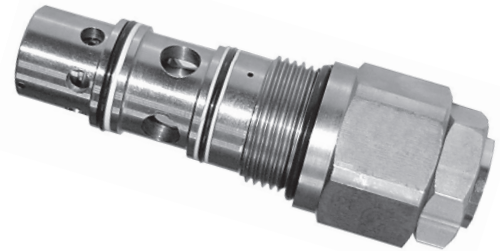
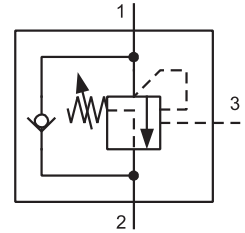

Functional Description

The valve consists of a seat by-pass, relief valve fitted with an auxiliary control with a differential piston and by-pass single-way valve serving for reverse direction of flow. The liquid is flowing through the single-way valve from the channel (2) to the channel (1) with a small pressure drop. In the opposite direction the single-way valve on the rear side of which a gate valve seat is fitted is pressed through the action of a spring and the load pressure against the spring-loaded valve gate valve. In this way the valve is nearly closed hermetically. If the pressure in the channel (1) exceeds a set up value of the spring force the gate valve is pressed out of the seat and the overpressure in that case is relieved into channel (2). For ensuring the function of holding the load the spring force should be set up to a value by 30 % higher when compared to an expected pressure exerted by the load.

If the load has to be moved it is possible to ensure it with the help of so called auxiliary control from the channel (3) by introducing already certain control pressure.

The control pressure is calculated in the following way:

$$\text{Control pressure} = \frac{\text{set up pressure} - \text{load pressure}}{\text{ratio of control}}$$

The ratio of control designates a ratio of surfaces of the differential slide valve cross-section area and its seat. Therefore, the necessary control pressure for opening the valve does not correspond to the difference between the set up pressure and load pressure however; it corresponds to the ratio of this difference and the control ratio. In the formula as mentioned above it is necessary to take into consideration that in differential cylinders it is necessary to add to the control ratio also the appropriate ratio of piston surfaces in the direction of movement.

As soon as the control pressure attains a necessary value the differential gate valve is moved out from the seat and then the way from the channel (1) to the channel (2) is released. If now the load tries to accelerate and be fast as for the oil supply the supply pressure decreases, therefore, also the control pressure in the channel (3) is decreased. The spring force tries to shut off the valve again, therefore, in consequence of which the flow from the consumer decreases and the inlet pressure to the consumer increases again. In this way it is ensured a constant inlet pressure by means of which the movement of the load can be controlled.

As for appropriate basic surface finish the external parts are zinc coated.

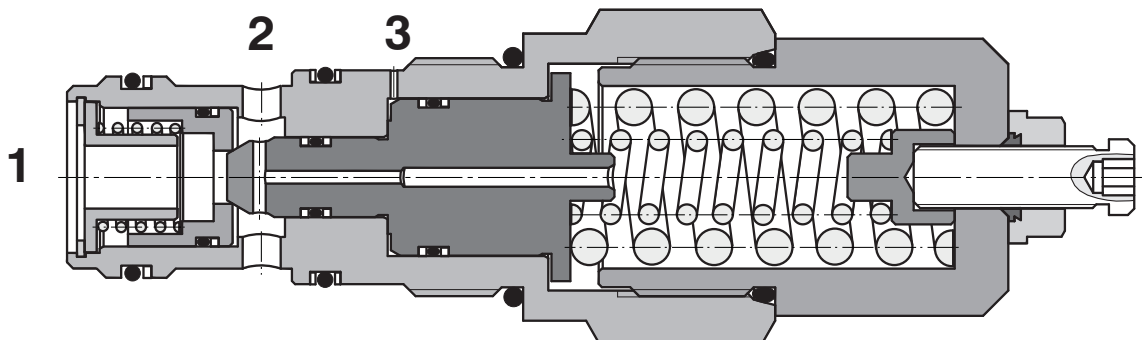

Ordering Code

SO5A-T3/I



Overcentre valve

No designation

**Seals
NBR**

Pilot ratio

Standard	4:1	4
for relatively constant	6:1	6

Technical Data

Cavity		M38 x 2
Maximum flow	L/min	140
Max. pressure	bar	340
Max. input pressure	bar	420
Pressure drops	bar	see $\Delta p - Q$ characteristics
Hydraulic fluid		Hydraulic oil (HM, HV) according to DIN 51524
Fluid temperature range	°C	-20 ... +90
Viscosity	mm ² /s	20 ... 400
Maximum degree of fluid contamination		according to ISO 4406, Class 21/18/15
Weight	kg	1.20
Maximum valve tightening torque in valve body or in control block	Nm	150 ⁺²
Mounting position		Unrestricted

$\Delta p - Q$ Characteristics

Measured at $v = 40 \text{ mm}^2/\text{s}$

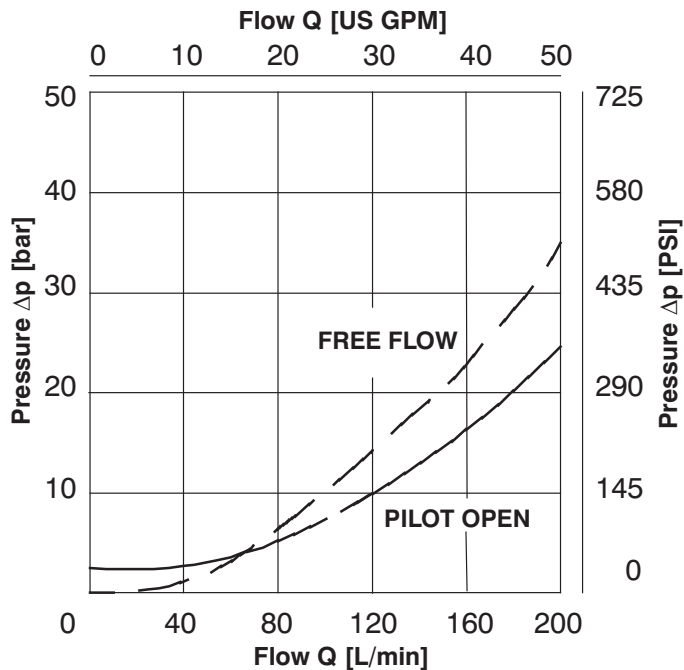

5

Dimensions

Measurements in millimeters

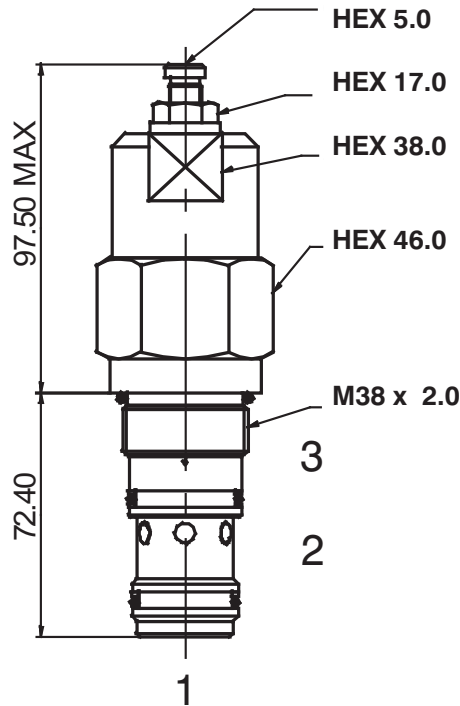

Cavity

Measurements in millimeters

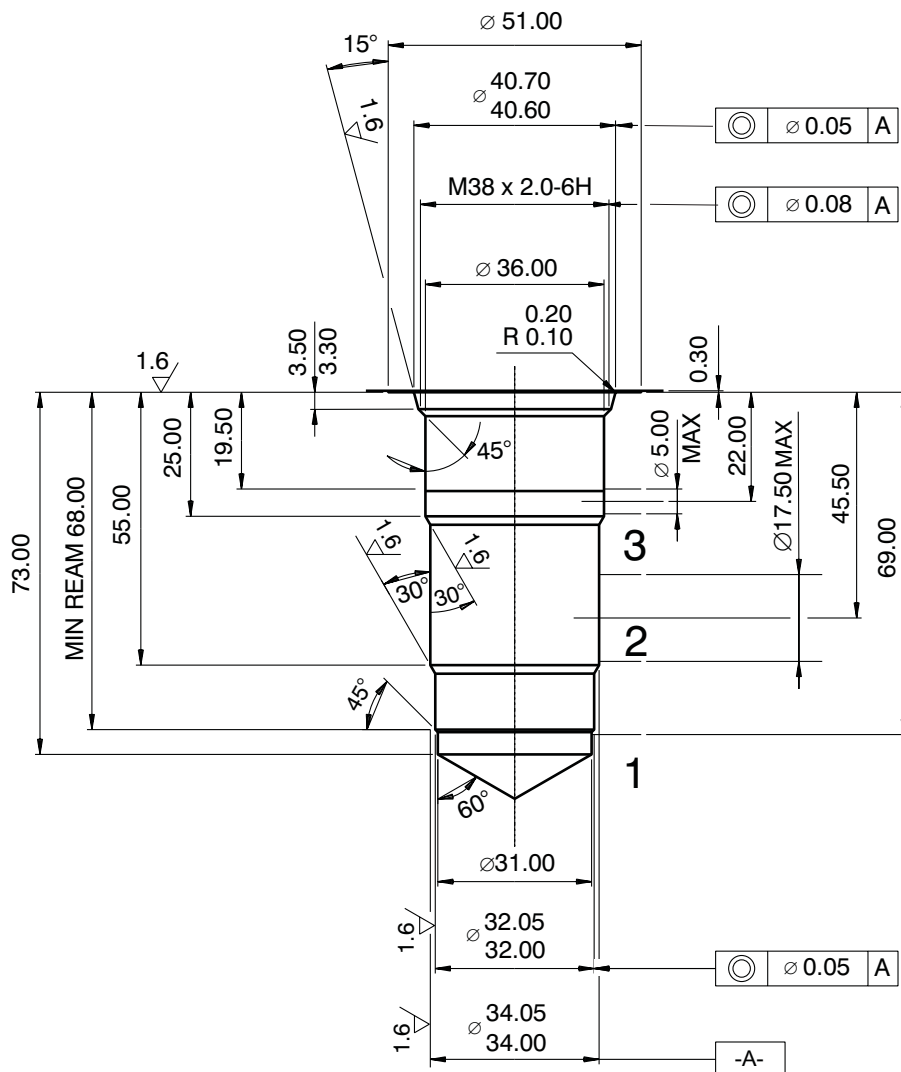

5

Valve Bodies

Measurements in millimeters

ISO A

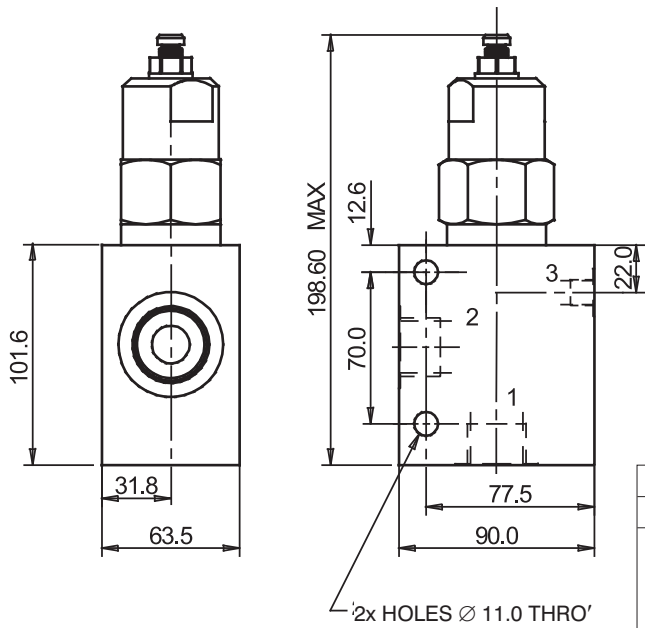
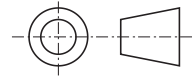

Body without valve			
Material	Ports	Port size	Type code
Aluminium	1, 2	G1"	SB-T3-0109AL
	3	G1/4	
	1, 2	SAE 16, 1-5/16-12	SB-T3-0110AL
	3	SAE 6, 9/16-18	
Steel	1, 2	G1"	SB-T3-0109ST
	3	G1/4	
	1, 2	SAE 16, 1-5/16-12	SB-T3-0110ST
	3	SAE 6, 9/16-18	

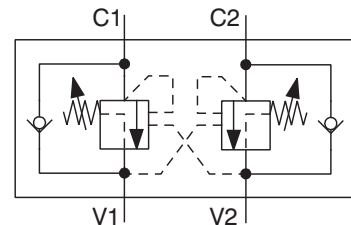
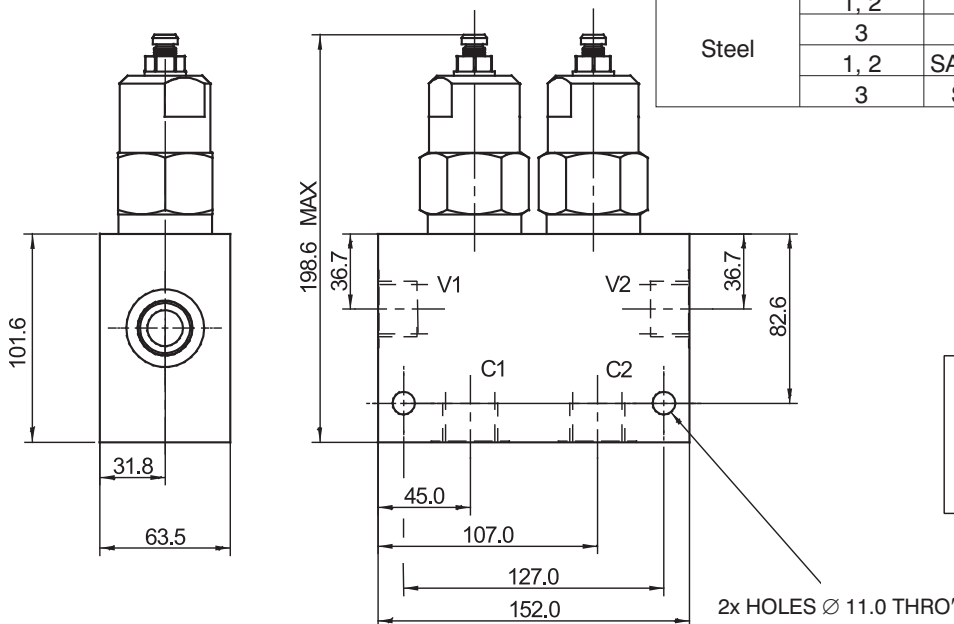

Dual body without valve			
Material	Ports	Port size	Type code
Aluminium	C1, C2, V1, V2	G1"	SB-T4-0209AL
	C1, C2, V1, V2	SAE 16, 1-5/16-12	SB-T4-0210AL
Steel	C1, C2, V1, V2	G1"	SB-T4-0209ST
	C1, C2, V1, V2	SAE 16, 1-5/16-12	SB-T4-0210ST

The use of aluminium bodies is limited to a maximum operating pressure of 210 bar.

Spare Parts

Seal kits on request.

Caution!

- The packing foil is recyclable.
- The technical information regarding the product presented in this catalogue is for descriptive purposes only. It should not be construed in any case as a guaranteed representation of the product properties in the sense of the law.

ARGO-HYTOS s.r.o. CZ - 543 15 Vrchlaví
 Tel.: +420-499-403111, Fax: +420-499-403421
 E-mail: sales.cz@argo-hytos.com
 www.argo-hytos.com

- The valve prevents runaway in the event of a negative load
- Load-holding without leakage
- Pressure relief function protecting the actuator against overload and pressure peaks
- When installed into the actuator the valve can be used as a hose burst valve
- When used as pressure relief the check valve will act as an anti-cavitation valve
- Relief setting is unaffected by back pressure
- The valve should be mounted as close as possible to the actuator

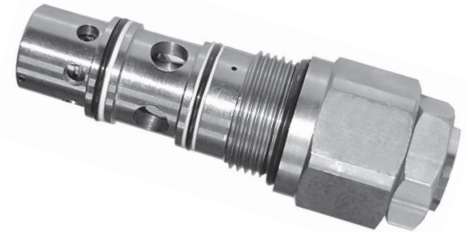
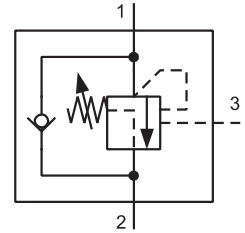

Functional Description

The valve consists of a seat by-pass, relief valve fitted with an auxiliary control with a differential piston and by-pass single-way valve serving for reverse direction of flow. The liquid is flowing through the single-way valve from the channel (2) to the channel (1) with a small pressure drop. In the opposite direction the single-way valve on the rear side of which a gate valve seat is fitted is pressed through the action of a spring and the load pressure against the spring-loaded valve gate valve. In this way the valve is nearly closed hermetically. If the pressure in the channel (1) exceeds a set up value of the spring force the gate valve is pressed out of the seat and the overpressure in that case is relieved into channel (2). For ensuring the function of holding the load the spring force should be set up to a value by 30 % higher when compared to an expected pressure exerted by the load.

If the load has to be moved it is possible to ensure it with the help of so called auxiliary control from the channel (3) by introducing already certain control pressure.

The control pressure is calculated in the following way:

$$\text{Control pressure} = \frac{\text{set up pressure} - \text{load pressure}}{\text{ratio of control}}$$

The ratio of control designates a ratio of surfaces of the differential slide valve cross-section area and its seat. Therefore, the necessary control pressure for opening the valve does not correspond to the difference between the set up pressure and load pressure however; it corresponds to the ratio of this difference and the control ratio. In the formula as mentioned above it is necessary to take into consideration that in differential cylinders it is necessary to add to the control ratio also the appropriate ratio of piston surfaces in the direction of movement.

As soon as the control pressure attains a necessary value the differential gate valve is moved out from the seat and then the way from the channel (1) to the channel (2) is released. If now the load tries to accelerate and be fast as for the oil supply the supply pressure decreases, therefore, also the control pressure in the channel (3) is decreased. The spring force tries to shut off the valve again, therefore, in consequence of which the flow from the consumer decreases and the inlet pressure to the consumer increases again. In this way it is ensured a constant inlet pressure by means of which the movement of the load can be controlled.

As for appropriate basic surface finish the external parts are zinc coated.

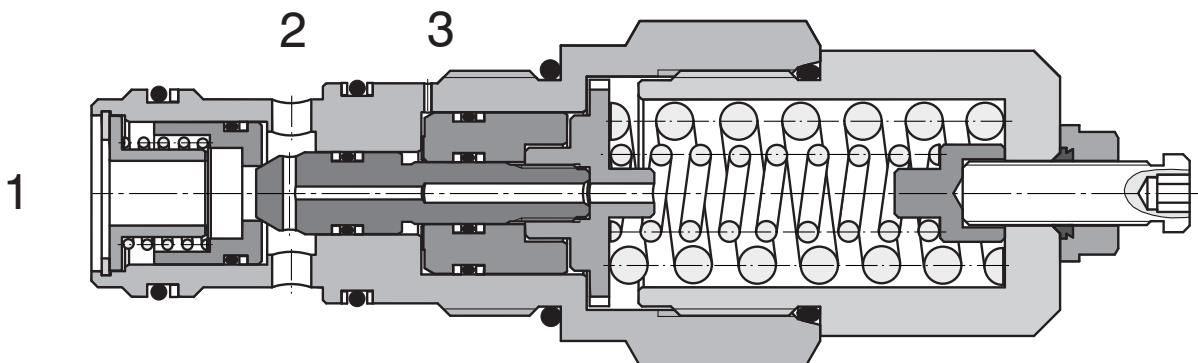

Ordering Code

SOP5A-T3/I



Overcentre valve

No designation

Seals
NBR

Pilot ratio

Standard	4:1	4
for relatively constant	6:1	6

Technical Data

Cavity		M38 x 2
Maximum flow	L/min	140
Max. pressure	bar	340
Max. input pressure	bar	420
Pressure drops	bar	see $\Delta p - Q$ characteristics
Hydraulic fluid		Hydraulic oil (HM, HV) according to DIN 51524
Fluid temperature range	°C	-20 ... +90
Viscosity	mm ² /s	20 ... 400
Maximum degree of fluid contamination		according to ISO 4406, Class 21/18/15
Weight	kg	1.2
Maximum valve tightening torque in valve body or in control block	Nm	150 ⁺²
Mounting position		Unrestricted

$\Delta p - Q$ Characteristics

Measured at $v = 40 \text{ mm}^2/\text{s}$

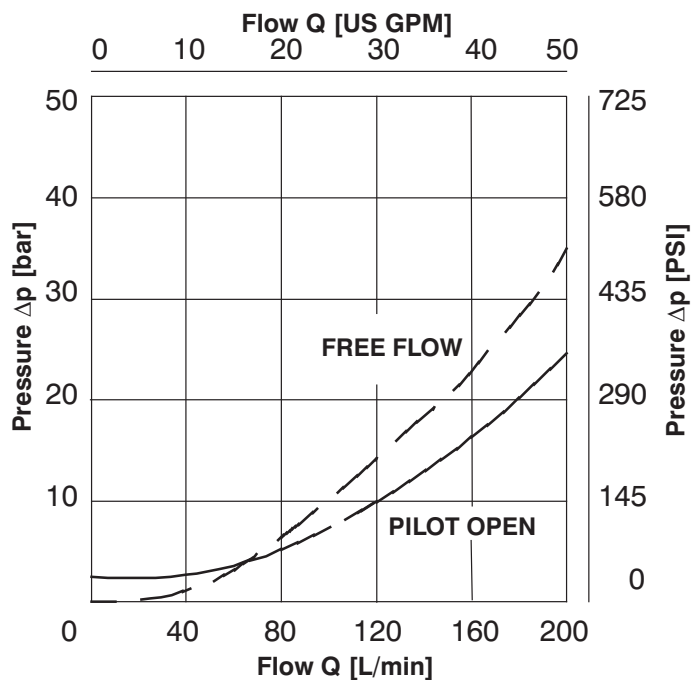

5

Dimensions

Measurements in millimeters

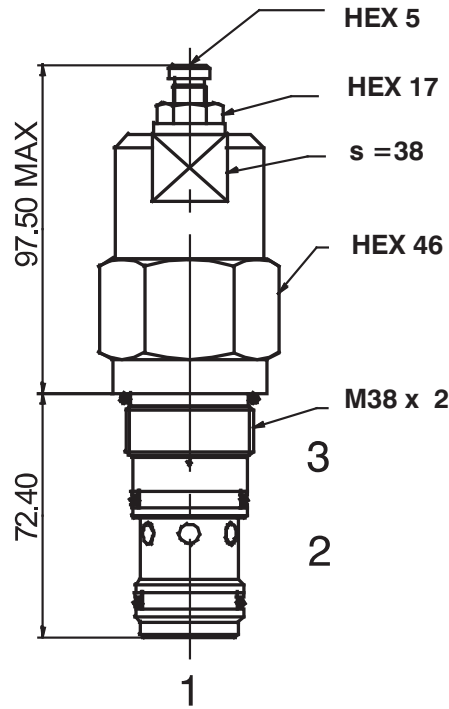

5

Cavity

Measurements in millimeters

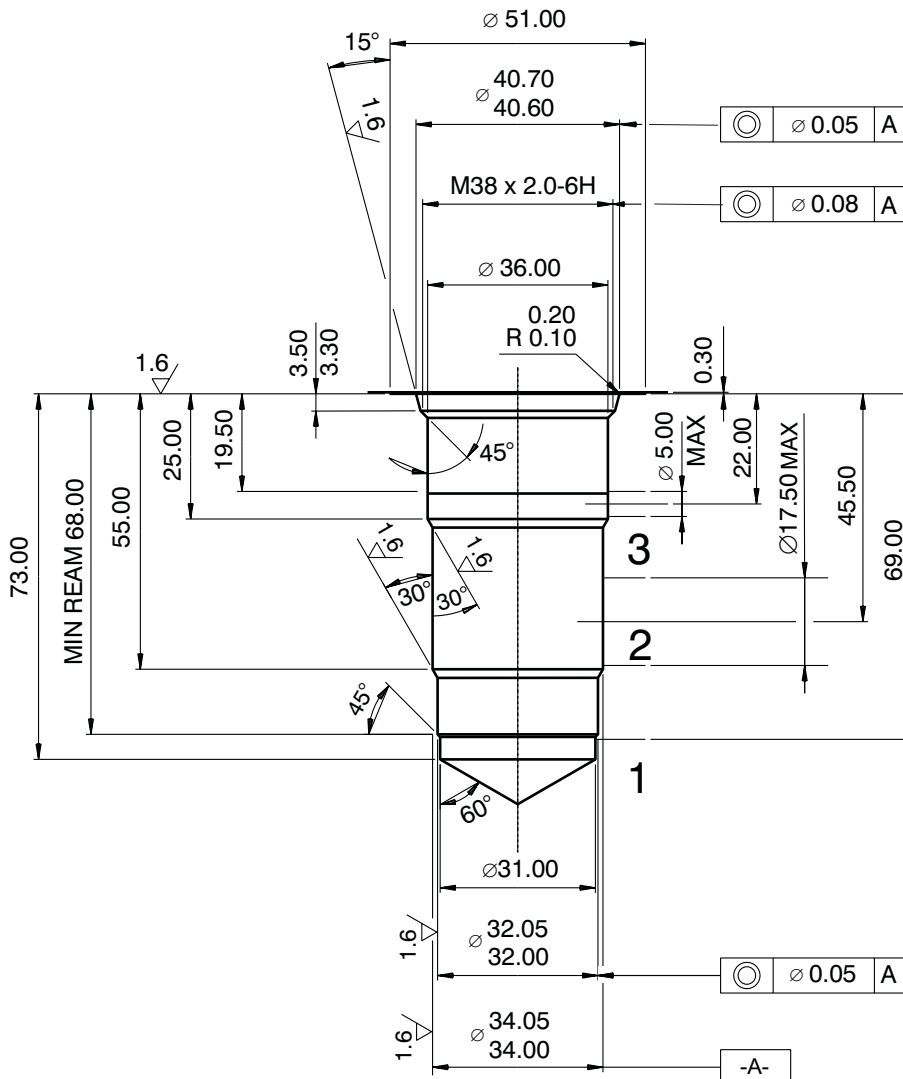

Valve Bodies

Measurements in millimeters

ISO A

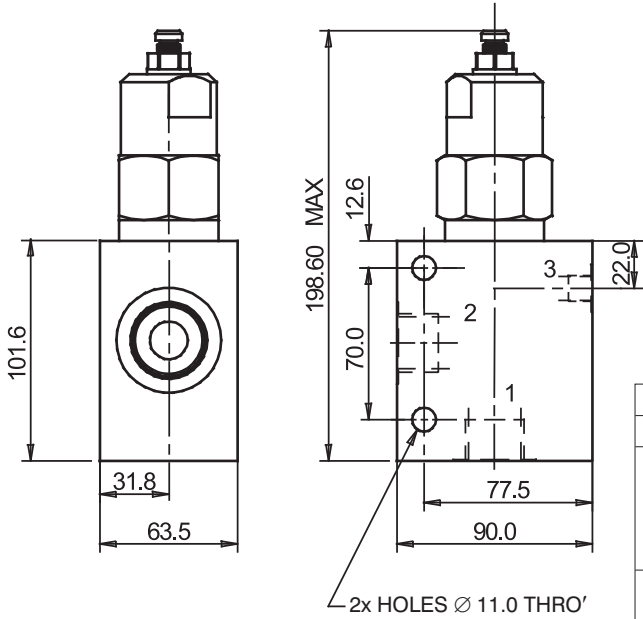
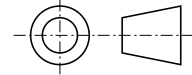

Body without valve			
Material	Ports	Port size	Type code
Aluminium	1, 2	G1"	SB-T3-0109AL
	3	G1/4	
	1, 2	SAE 16, 1-5/16-12	SB-T3-0110AL
	3	SAE 6, 9/16-18	
Steel	1, 2	G1"	SB-T3-0109ST
	3	G1/4	
	1, 2	SAE 16, 1-5/16-12	SB-T3-0110ST
	3	SAE 6, 9/16-18	

5

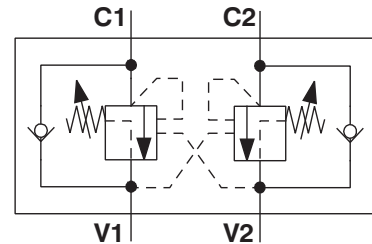
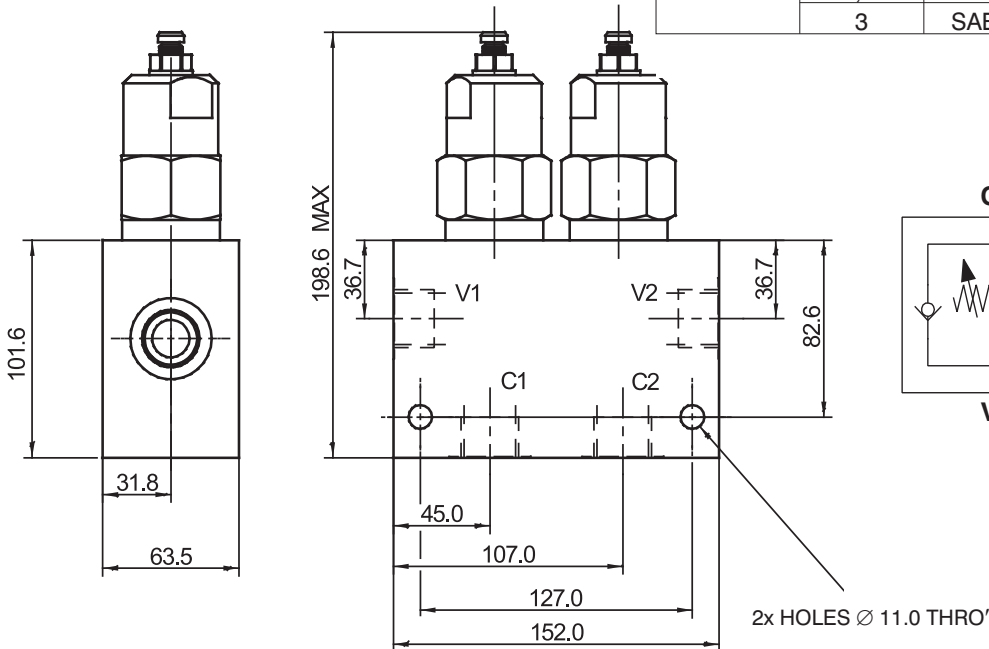

Dual body without valve			
Material	Ports	Port size	Type code
Aluminium	C1, C2, V1, V2	G1"	SB-T4-0209AL
	C1, C2, V1, V2	SAE 16, 1-5/16-12	SB-T4-0210AL
Steel	C1, C2, V1, V2	G1"	SB-T4-0209ST
	C1, C2, V1, V2	SAE 16, 1-5/16-12	SB-T4-0210ST

The use of aluminium bodies is limited to a maximum operating pressure of 210 bar.

Spare Parts

Seal kits on request.

Caution!





- The packing foil is recyclable.
- The technical information regarding the product presented in this catalogue is for descriptive purposes only. It should not be construed in any case as a guaranteed representation of the product properties in the sense of the law.

ARGO-HYTOS s.r.o. CZ - 543 15 Vrchlaví
 Tel.: +420-499-403111, Fax: +420-499-403421
 E-mail: sales.cz@argo-hytos.com
 www.argo-hytos.com

Proportional Valves

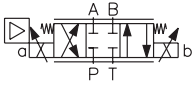
6

Proportional Valves

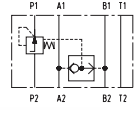
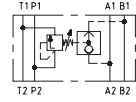
Symbol example	Flow l/min (GPM)	Pressure bar (PSI)	Type Code	Cartridge	NFPA D02, CETOP 2; NG4	NFPA D03, CETOP 3; NG6	NFPA D05, CETOP 5, NG10	Line Mounted	Page	Data Sheet
Proportional Directional Control Valves										
	20 (5)	320 (4600)	PRM2-04		X				6.01	HA 5105
	20 (5)	320 (4600)	PRM7-04		X				6.04	HA 5120
	40 (11)	350 (5100)	PRM2-06			X			6.02	HA 5104
	40 (11)	350 (5100)	PRM7-06			X			6.05	HA 5119
	80 (21)	350 (5100)	PRM6-10				X		6.03	HA 5115
	80 (21)	350 (5100)	PRM7-10				X		6.06	HA 5116
	140 (37)	350 (5100)	PRM8-06			X			6.21	HA 5178
Proportional Directly Operated Pressure Relief Valves										
	1,5 (0,4)	350 (5100)	SR1P2-A2	X	(X)			(X)	6.07	HA 5122
Proportional Pilot Operated Pressure Relief Valves										
	60 (16)	350 (5100)	SR4P2-B2	X		(X)		(X)	6.08	HA 5117
Proportional Directly Operated Pressure Reducing Valves										
	20 (5)	50 (700)	PP2P			X		(X)	6.09	HA 5125
	20 (5)	50 (700)	PVRM1-06/S	X					6.10	HA 5108
	40 (11)	50 (700)	PVRM3/10	X					6.11	HA 5118
Proportional Pilot Operated Pressure Reducing Valves										
	60 (16)	350 (5100)	SP4P2-B3	X		(X)		(B)	6.12	HA 5123
2 Way Pressure Compensators										
	16 (4)	350 (5100)	TV2-042/M		X				6.16	HA 5167
	35 (9)	350 (5100)	TV2-062/M			X			6.17	HA 5166
	80 (21)	350 (5100)	TV2-102	X			(X)		6.18	HA 5169
3 Way Pressure Compensators										
	15	350 (5100)	TV2-043/M		X				6.19	HA 5168
	35 (9)	350 (5100)	TV2-063/M			X			6.19	HA 5168
	80 (21)	350 (5100)	TV2-103	X			(X)		6.20	HA 5170
Electronic Controllers for Proportional Valves										
EL3E-12, EL3E-24	-	-							6.14	HA 9145
EL4	-	-							6.15	HA 9140
EL6	-	-							6.13	HA 9150

- Compact design with integrated electronics
- High reliability
- Simple replacement of the exciting coils including electronics without opening the hydraulic circuits
- Continuous flow control in both directions
- Installation dimensions to DIN 24 340 / ISO 4401 / CETOP RP121-H

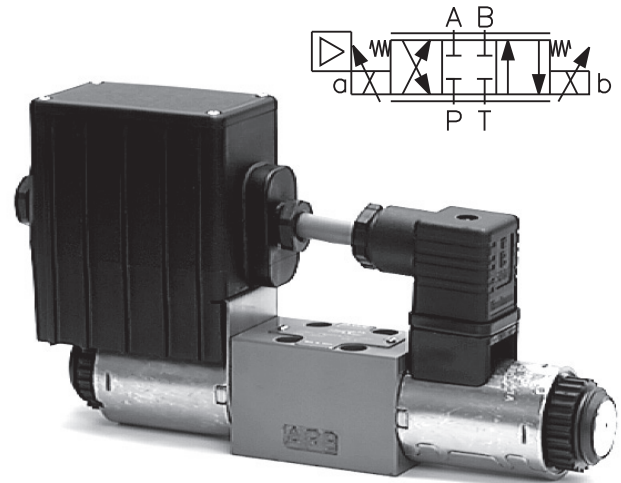

Functional Description

The proportional directional valve consists of a cast-iron housing, a special control spool, two centering springs with supporting washers and one or two proportional solenoids. A control box, which comprises one or two electronic control cards, depending on the number of the controlled solenoids, can be mounted onto either solenoid. With the model with two solenoids, the solenoid mounted apposite the control box is connected with the box by means of a DIN connector, a two-cored cable and a bushing. The connection of the control box with the supply source and with the control signal is realized by means of a 4-pin connector, type M12 x 1. The solenoid coils, including the control box, can be turned in the range of $\pm 90^\circ$. The electric control unit supplies the solenoid with current, which varies with the control signal. The solenoid shifts the control spool to the required position, proportional to the control current.

The electronic control unit provides the following adjustment possibilities: Offset, Gain, rise and drop-out time of the ramp generator, frequency (2 frequencies) and amplitude of the dither signal generator. The correct function of the control unit is signaled by LED-diodes. Stabilized voltage +10V (+5V for 12V voltage) is also available for the user. By the use of this voltage, a voltage control signal can be made by means of a potentiometer $\geq 1 \text{ k}\Omega$. The electronic control card enables voltage or current control to be used, according to the positions of the switches SW1 to SW3 (see table on page 6). The basic surface treatment of the valve housing is phosphate coated and the operating solenoids are zinc coated.

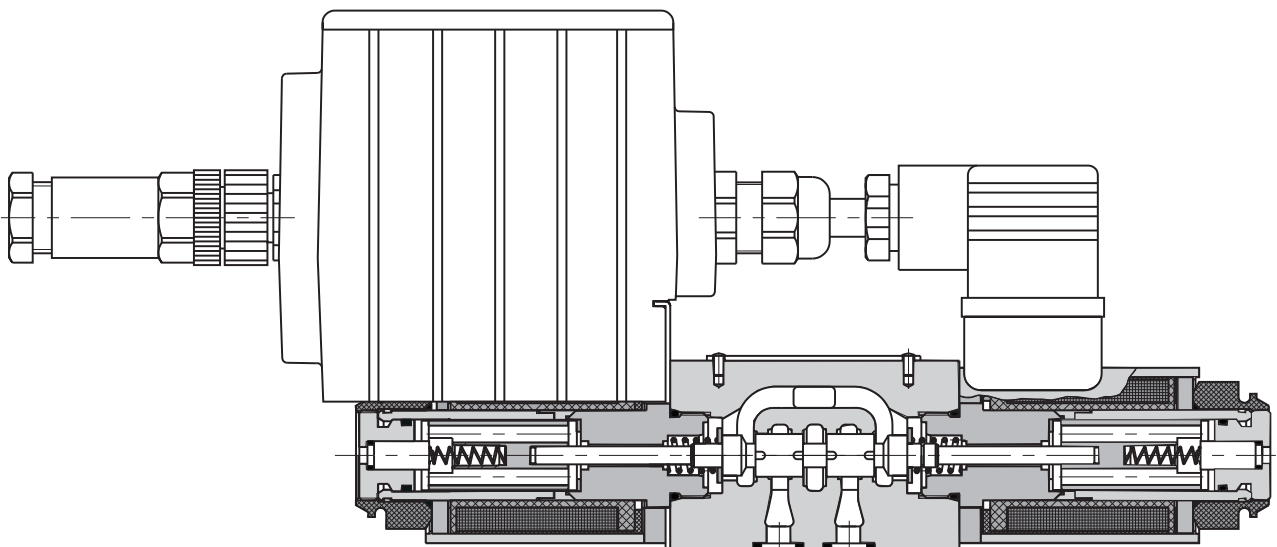

Ordering Code

PRM2-04 / -

Proportional Directional Control Valve

Seals

without designation
V

NBR
FPM (Viton)

Nominal size

Electronics

without designation without electronics

EK

connection by connector
M12 x 1 (4-pin connector)
(supplied with counterpart)

Nominal supply voltage

12
24

12 V DC
24 V DC

Nominal flow rate at $\Delta p = 10$ bar

4
8
12

4 L/min
8 L/min
12 L/min

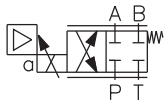

2Z51

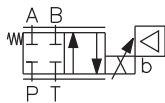

2Z11

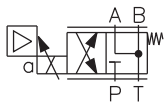

2Y51

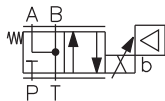

2Y11

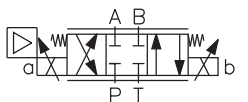

3Z11

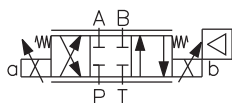

3Z11B

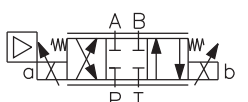

$$\frac{q_A}{q_B} = \frac{1}{2}^*$$

3Z12

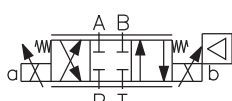

$$\frac{q_A}{q_B} = \frac{1}{2}^*$$

3Z12B

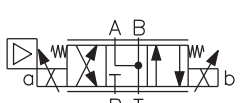

3Y11

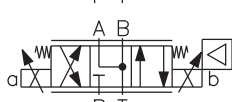

3Y11B

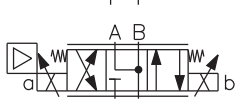

$$\frac{q_A}{q_B} = \frac{1}{2}^*$$

3Y12

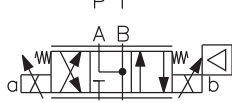

$$\frac{q_A}{q_B} = \frac{1}{2}^*$$

3Y12B

* Model for cylinders with asymmetric piston rod, piston area ratio 1:2

Technical Data

Nominal size	mm	04
Maximum operating pressure at ports P, A, B	bar	320
Maximum operating pressure at port T	bar	210
Hydraulic fluid	Hydraulic oils of power classes (HL, HLP) to DIN 51524	
Fluid temperature range (NBR / Viton)	°C	-30 ... +80 / -20 ... +80
Ambient temperature, max.	°C	+50
Viscosity range	mm ² /s	20 ... 400
Maximum degree of fluid contamination	Class 21/18/15 according to ISO 4406	
Nominal flow rate Q _n at Δp = 10 bar (v = 32 mm ² ·s ⁻¹)	L/min	4, 8, 12
Hysteresis	%	≤ 6
Weight PRM2-042 PRM2-043	kg	0.9 1.25
Mounting position	unrestricted, preferably horizontal	
Enclosure type EN 60 529	IP65	

Technical Data of the Proportional Solenoid

Nominal supply voltage	V	12 DC	24 DC
Limit current	A	1.7	0.8
Mean resistance value at 20°C	Ω	5	21

Technical Data of the Electronics

Nominal supply voltage U _{cc}	V	12 DC	24 DC
Supply voltage range	V	11.2... 14.7	20 ... 30 DC
Stabilized voltage for control	V	5 DC (R > 1kΩ)	10 DC (R ≥ 1 kΩ)
Control signal	see table of switches configuration (page 6)		
Maximum output current	A	2.4 for R < 4Ω	1.5 for R < 10Ω
Ramp adjustment range	s	0.05 ... 3	
Dither frequency	Hz	90/60	
Dither amplitude	%	0 ... 30	

Limit Power

Measured at v = 32 mm²/s P → A / B → T or P → B / A → T

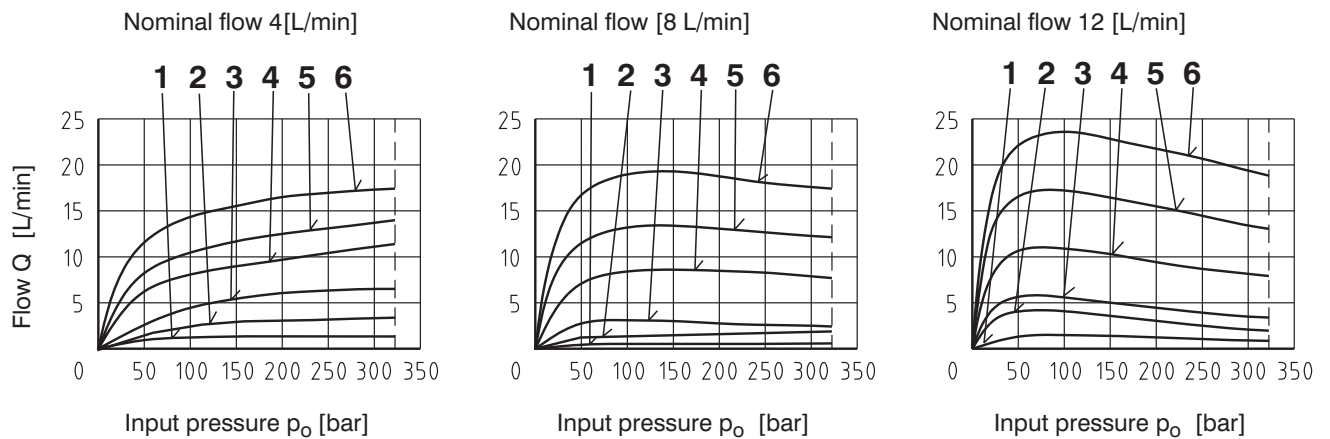

Solenoid current:

- 1 = 50%
- 2 = 60%
- 3 = 70%
- 4 = 80%
- 5 = 90%
- 6 = 100%

Flow Characteristic with Integrated Electronics

Measured at $\Delta p = 10 \text{ bar}$, $v = 32 \text{ mm}^2/\text{s}$

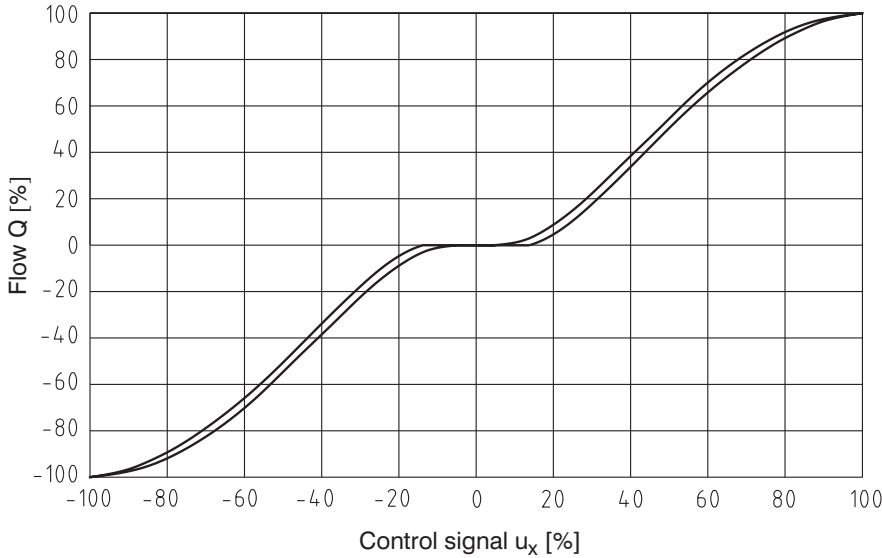

Flow Characteristic without Integrated Electronics

Measured at $\Delta p = 10 \text{ bar}$, $v = 32 \text{ mm}^2/\text{s}$,

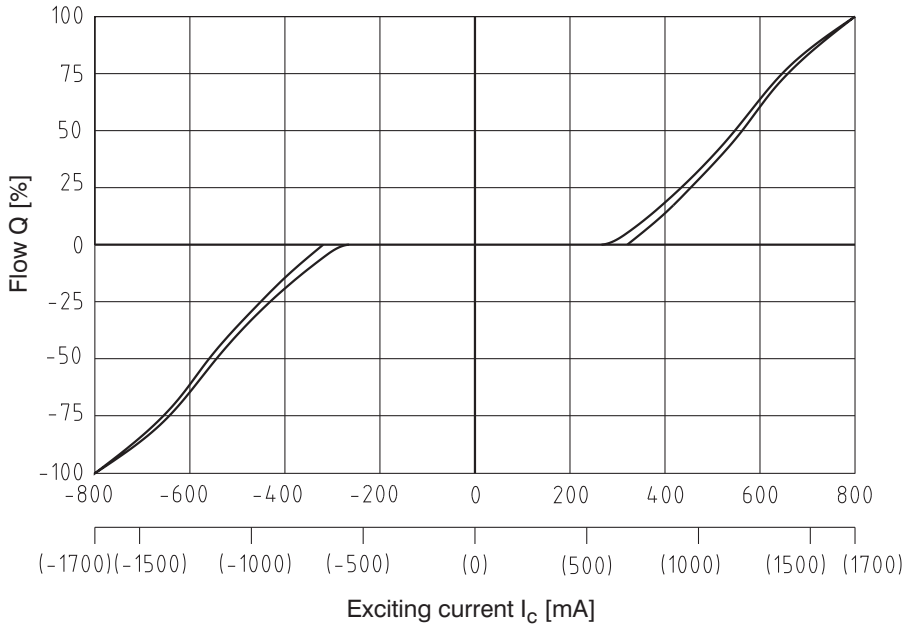

Values in parenthesis are valid for the supply voltage 12 V.

The coil current which initializes the flow through the proportional directional valve can differ due to the production tolerances about in a range of $\pm 6\%$ of the limit current.

Transient Characteristic

Measured at $\Delta p = 10 \text{ bar}$, $v = 32 \text{ mm}^2/\text{s}$; $Q = 80 \% Q_n$

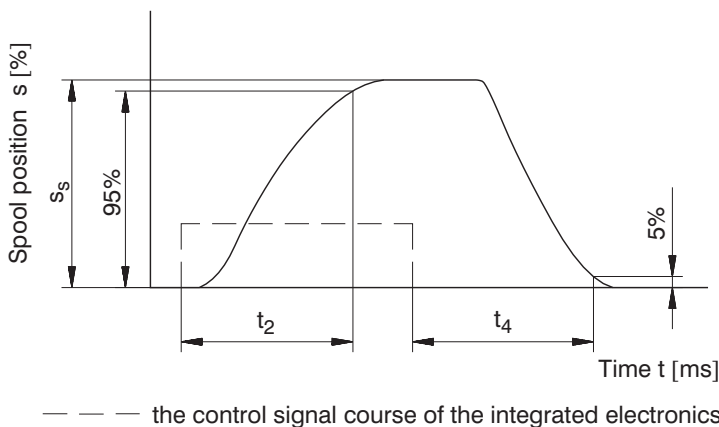

Steady spool position s_s [%]	t_2 [ms]	t_4 [ms]
100	75	70
75	70	55
50	50	40
25	35	25

The values in table have only an informative character.

The times of the transient characteristics at pressure or flow control will be in a particular hydraulic circuit always longer.

Frequency Reponse

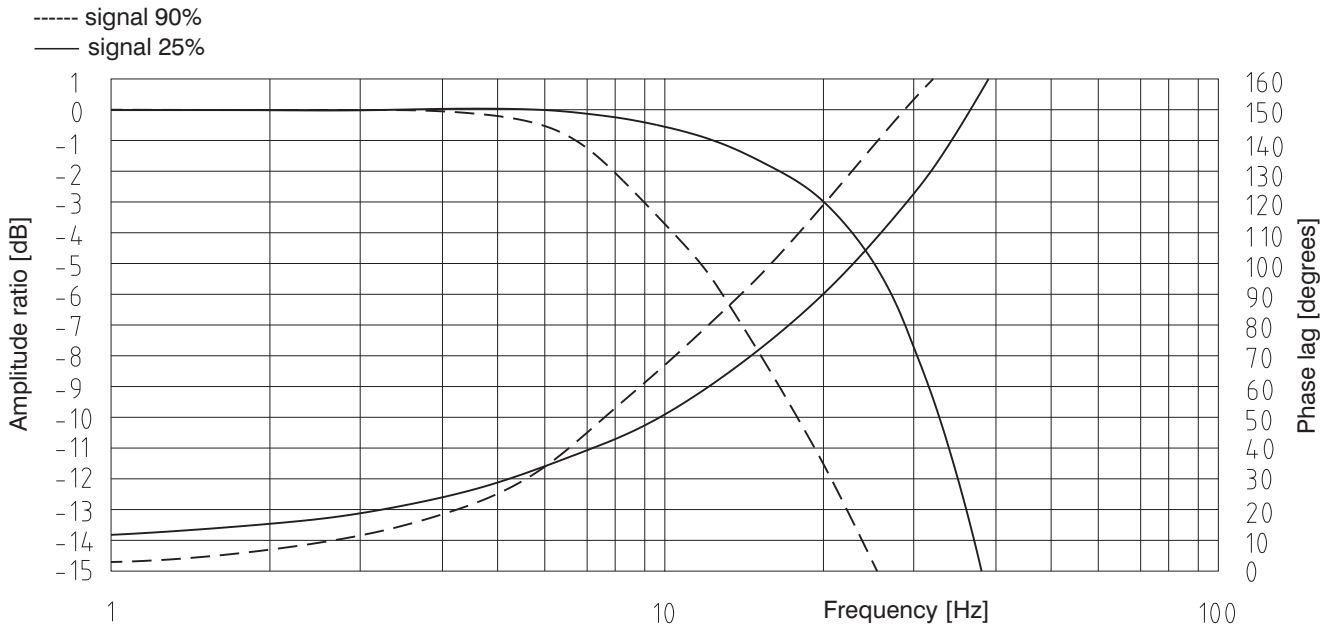

Component Arrangement on the Electronic Card

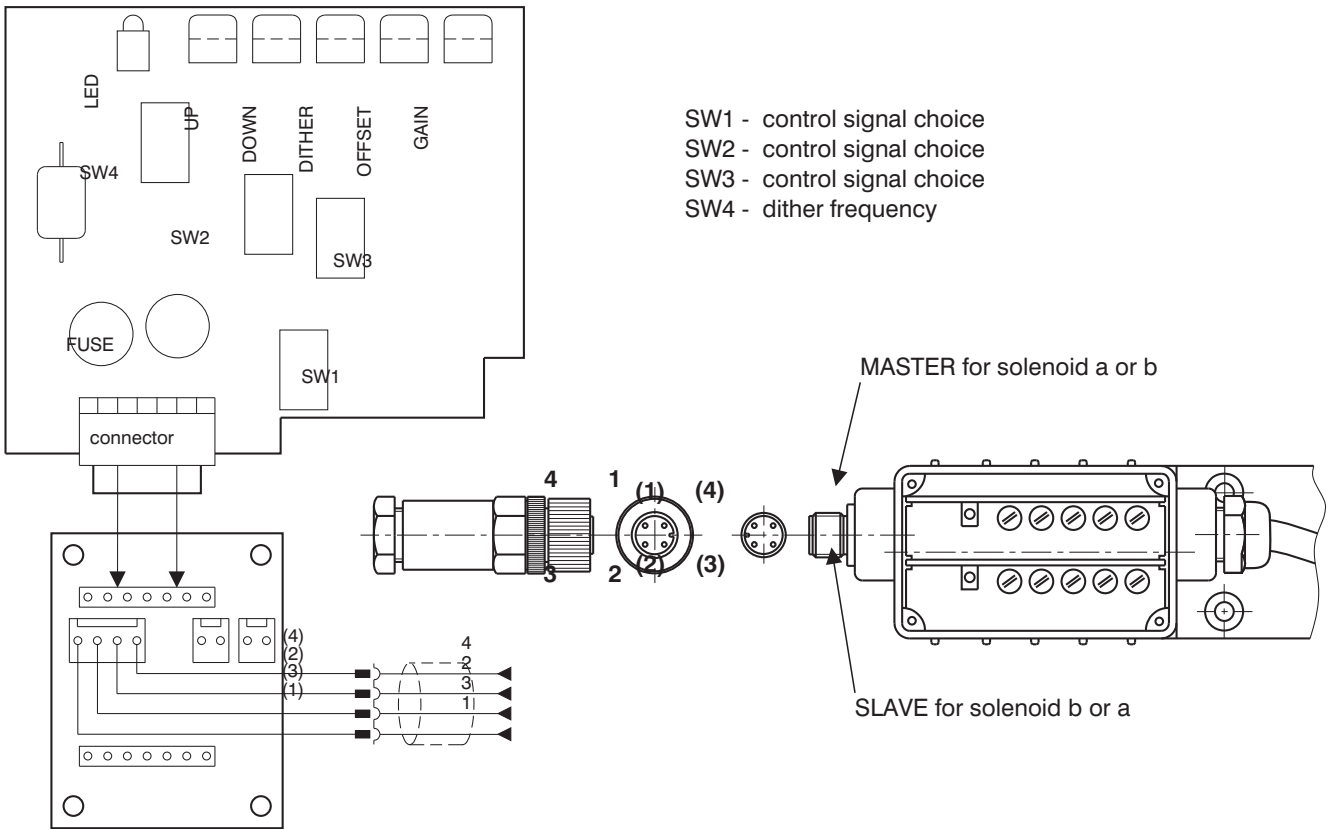

Description basic subplatte

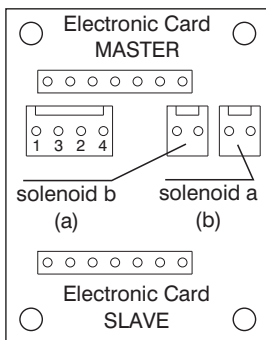

PIN	Description
1	+24 V (U_{CC}) (+12 V)
2	control
3	0 V
4	+10 V (+5 V)

6

Table of the Switch Configuration for the Control Signal Choices

		PRM2-042				PRM2-043	
		0 ... 5 V	0 ... 10 V (0 ... 5 V)*	0 ... 20 mA	4 ... 20 mA	$U_{cc}/2$ $\pm 10 V (\pm 5 V)^*$	$\pm 10 V$ $(\pm 5 V)^*$
MASTER M	SW1						
	SW2						
	SW3						
	SW4	90 Hz		60 Hz			
SLAVE S	SW1	X					
	SW2						
	SW3						
	SW4					90 Hz	60 Hz

6

Designation of the basic manufacture setting.



The ramp functions are adjusted on their minimum values, the dither is set to the optimal value with respect to hysteresis. Offset and Gain are adjusted according to the characteristic on page 3 and 4. The manufacturer does not recommend these adjusted values to be changed.

* Input signal level for the 12 V electronic unit.

Block Diagram

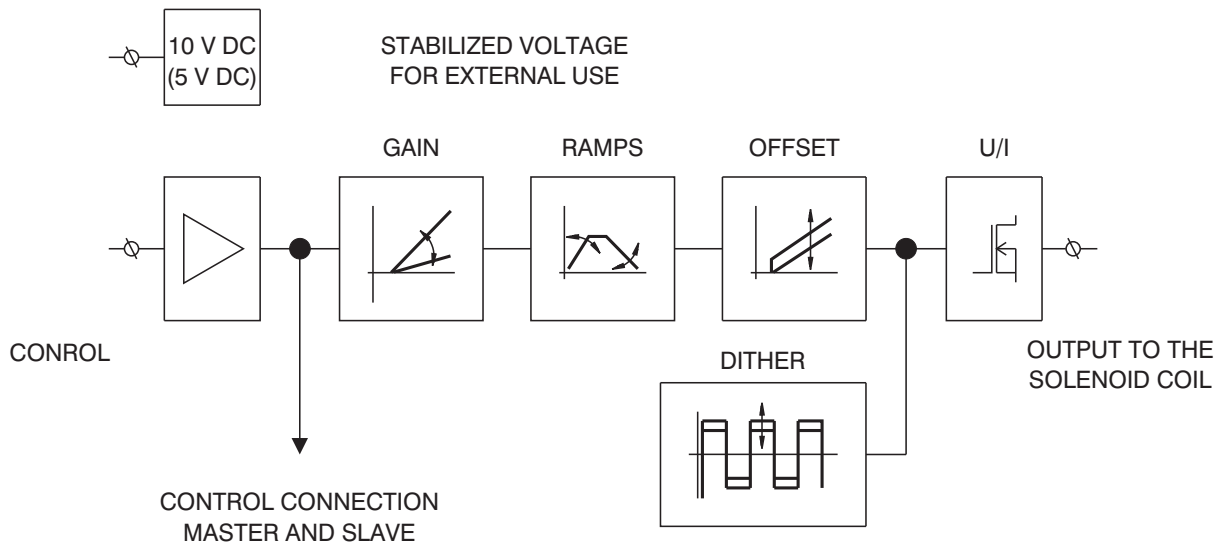

Valve PRM2-042 (with one solenoid)

1 Factory setting

1.1 Control with external voltage source 0 ... 10 V (0 ... 5 V) or with external potentiometer R > 1 kΩ

Notice:

The control signal must have the same ground potential as the supply source.

Master card for solenoid a (b)

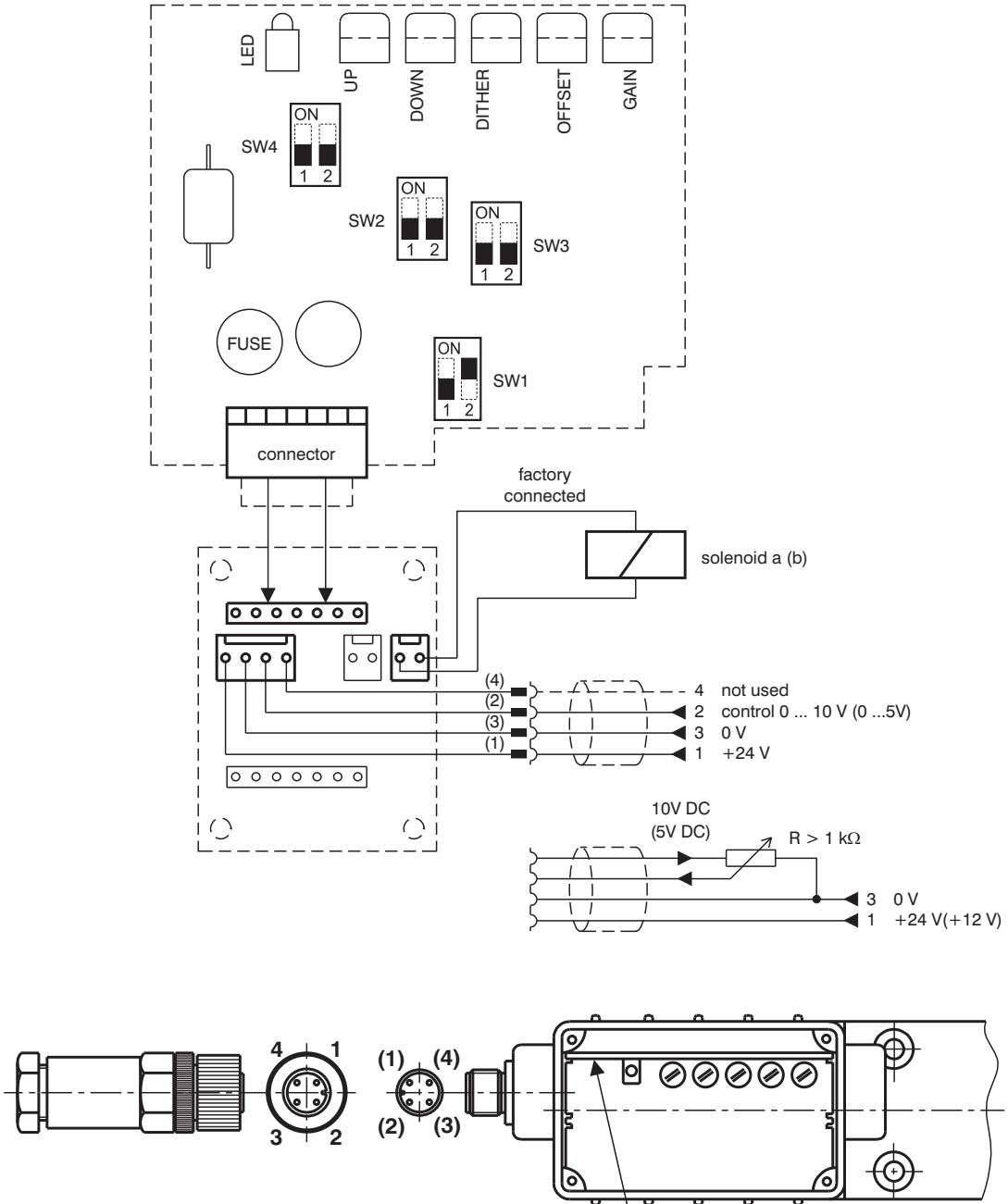

Wire colours (connection connector - electronics):

- (1) - brown
- (2) - white
- (3) - blue
- (4) - black

Factory set values:

Control signal: 0 - 10 V (0 - 5V)

Dither: frequency 90Hz
amplitude - optimum

Ramps: 0.05 s

Offset, Gain: according to the characteristics on page 3, 4

Valve PRM2-042 (with one solenoid)

2 Other control possibilities

2.1 Control with external source 0 ... 5 V

Notice:

The control signal must have the same ground potential as the supply source.

Master card for solenoid a (b)

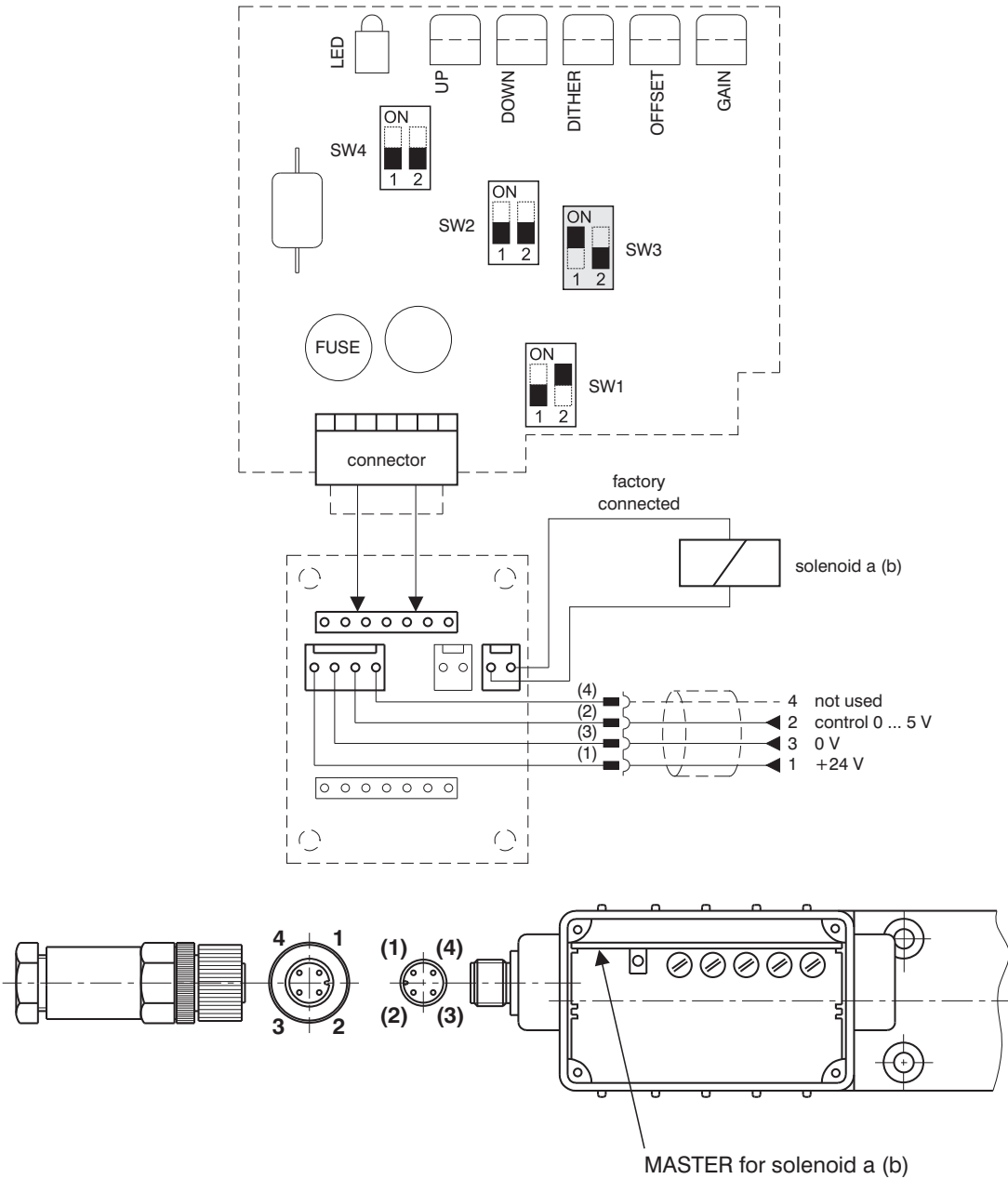

For the factory setting modification for this case of application, the following steps are required:

1. Unscrew the electronics cover
2. Carefully remove the Master card
3. Flip the switch SW3 in position shown in the picture
4. Put in the Master card and fix the electronics cover
5. Connect the voltage +24 V from an external supply source to terminals 1 and 3 of the connector
6. Connect the control voltage 0 ... 5 V from an external source to terminals 2 and 3 of the connector

Valve PRM2-042 (with one solenoid)

2.2 Control with external source 0 ... 20 mA

Notice:

The control signal must have the same ground potential as the supply source.

Master card for solenoid a (b)

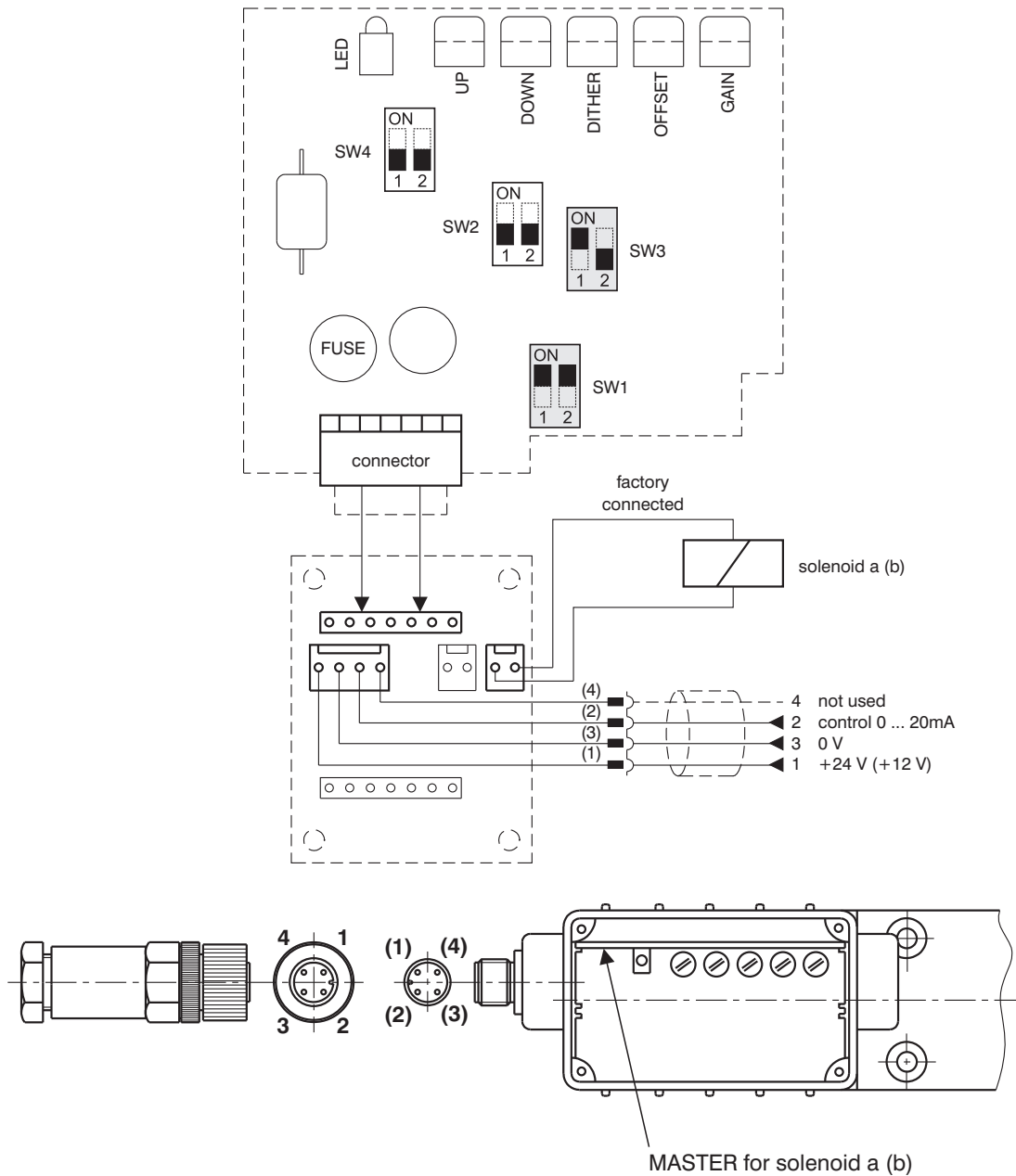

For the factory setting modification for this case of application, the following steps are required:

1. Unscrew the electronics cover
2. Carefully remove the Master card
3. Flip the switch SW1 and SW3 in position shown in the picture
4. Put in the Master card and fix the electronics cover
5. Connect the voltage +24 V (+12 V) from an external supply source to terminals 1 and 3 of the connector
6. Bring the control current 0 ... 20 mA from an external source to terminals 2 and 3 of the connector

Valve PRM2-042 (with one solenoid)

2.3 Control with external source 4 ... 20 mA

Notice:

The control signal must have the same ground potential as the supply source.

Master card for solenoid a (b)

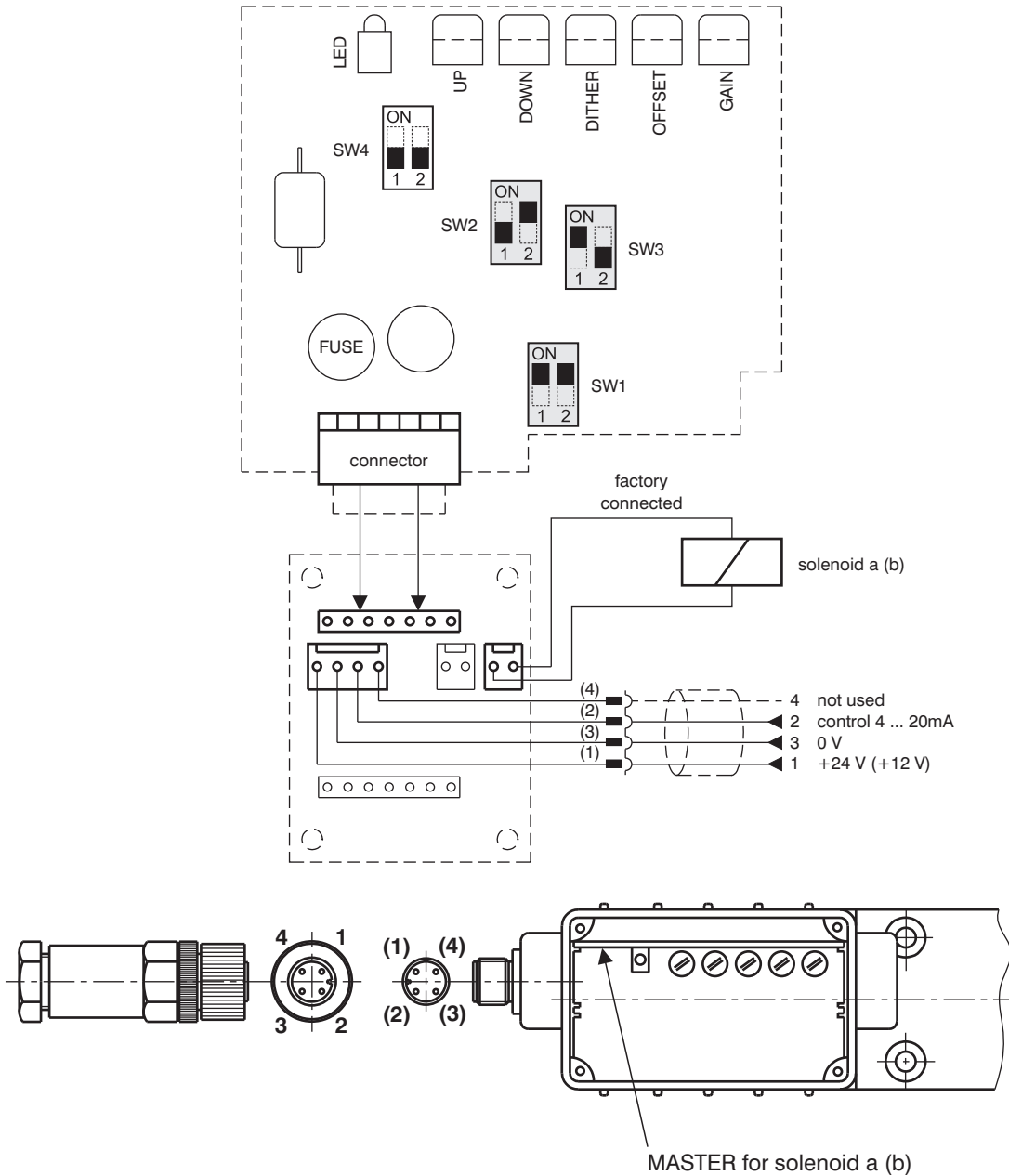

For the factory setting modification for this case of application, the following steps are required:

1. Unscrew the electronics cover
2. Carefully remove the Master card
3. Flip the switch SW1, SW2 and SW3 in position shown in the picture
4. Put in the Master card and fix the electronics cover
5. Connect the voltage +24 V (+12 V) from an external supply source to terminals 1 and 3 of the connector
6. Bring the control current 4 ... 20 mA from an external source to terminals 2 and 3 of the connector

Valve PRM2-043 (with two solenoids)

3 Factory setting

3.1 Control with external source $0 \pm 10 \text{ V}$ ($0 \pm 5 \text{ V}$)

Notice:

The control signal must have the same ground potential as the supply source.

Master card for solenoid a (b)

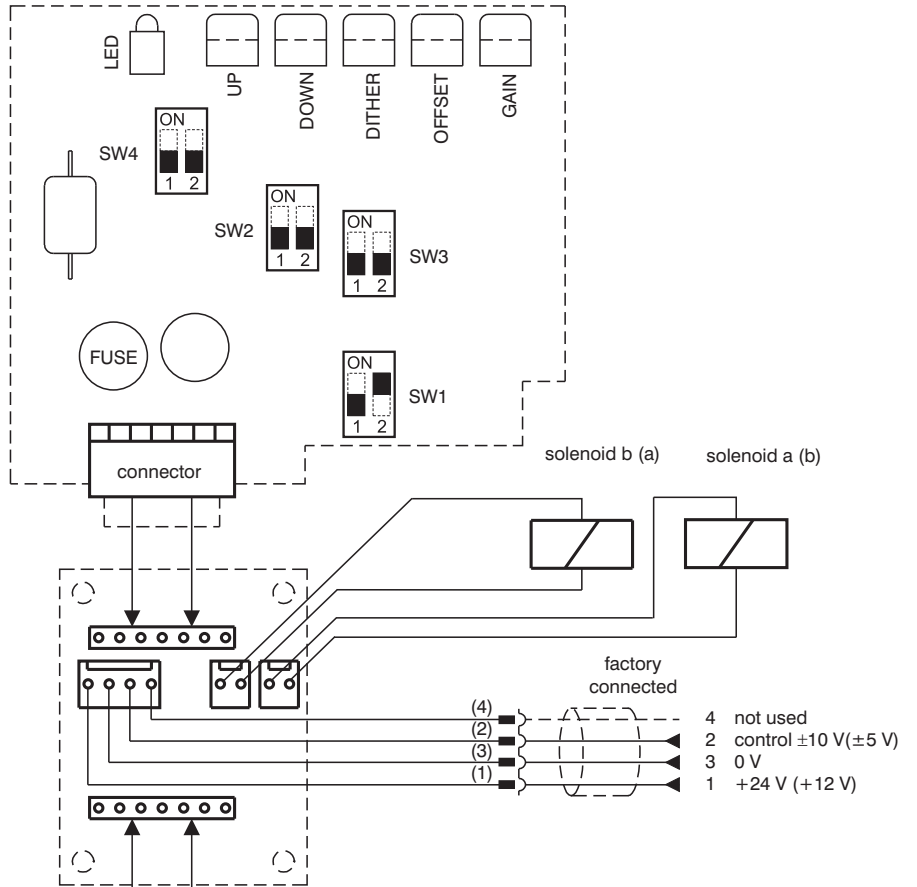

Slave card for solenoid b (a)

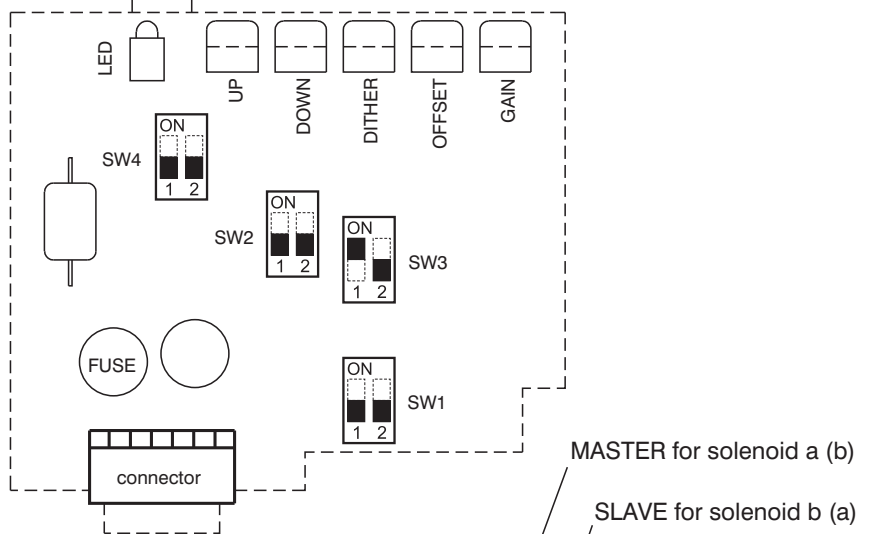

Factory set values:

Control signal: $0 \pm 10 \text{ V}$ ($0 \pm 5 \text{ V}$)

Dither: frequency 90 Hz
amplitude - optimum

Ramps: 0.05 s

Offset, Gain: according to the characteristics on page 3, 4

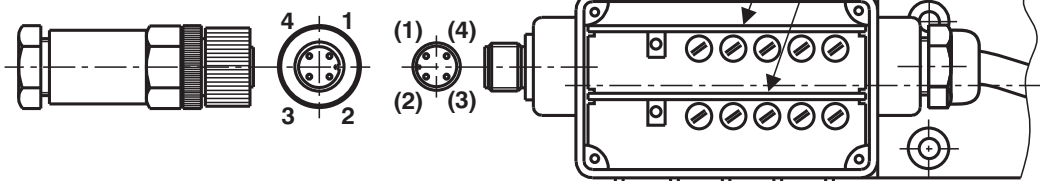

6

Valve PRM2-043 (with two solenoids)

3.2 Other control possibilities

Control $U_{cc}/2 \pm 10 V (U_{cc}/2 \pm 5V)$ external potentiometer $R > 1 k\Omega$

Master card for solenoid a (b)

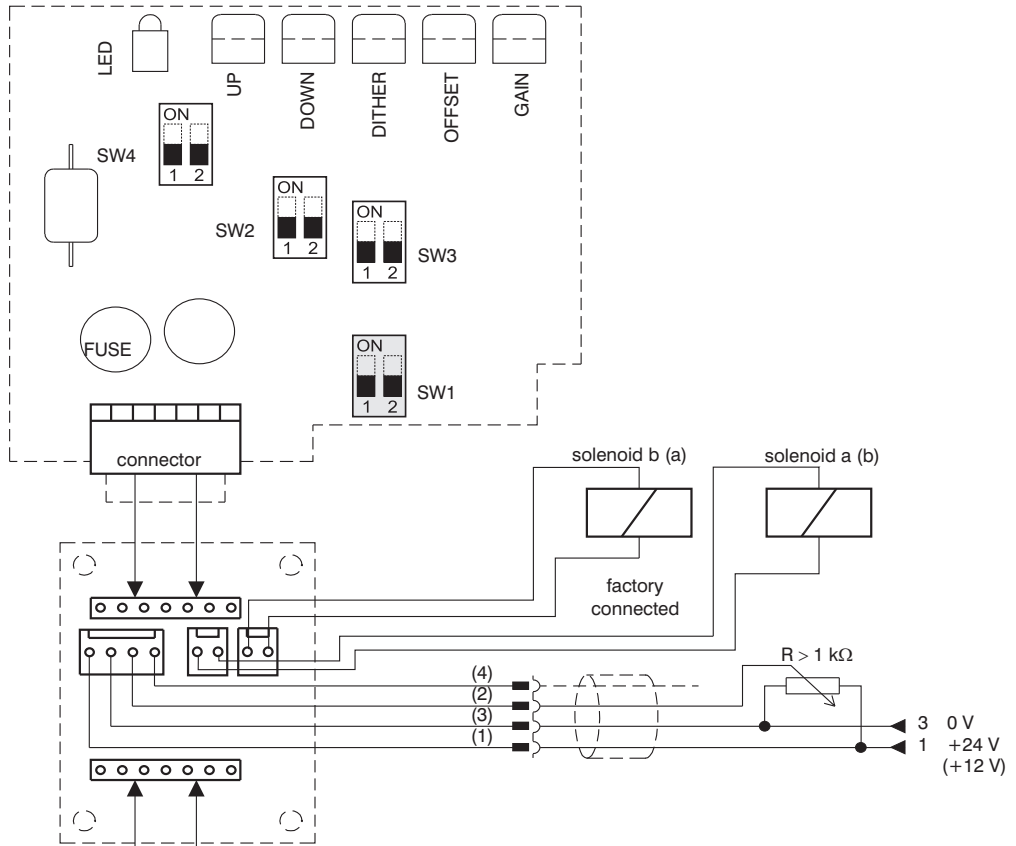

Slave card for solenoid b (a)

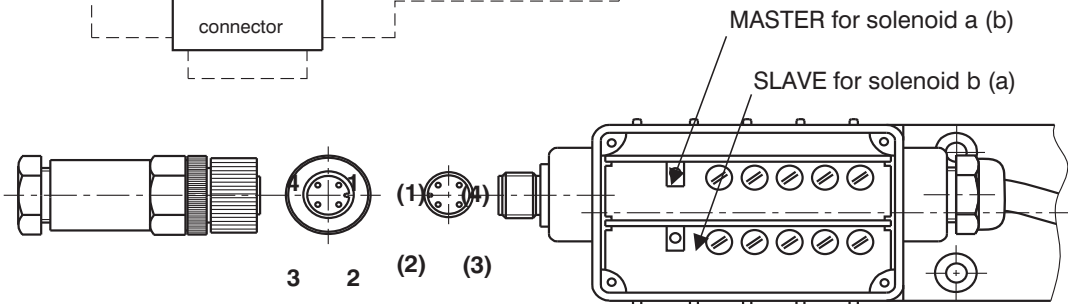
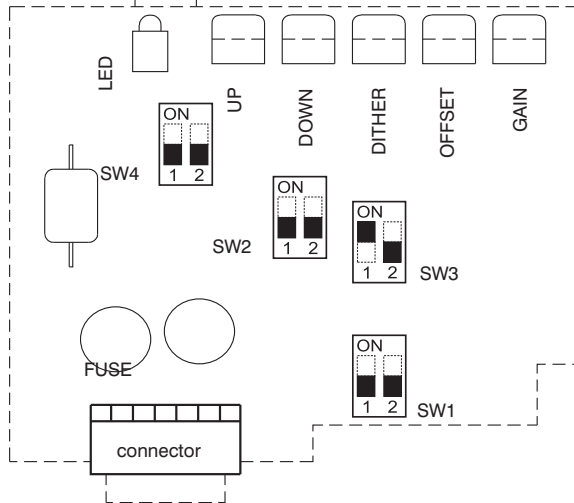

For the factory setting modification for this case of application, the following steps are required:

1. Unscrew the electronics cover
2. Carefully remove the Master card
3. Flip the switch SW1 in position shown in the picture
4. Put in the Master card and fix the electronics cover
5. Connect the voltage +24 V (+12 V) from an external supply source to terminals 1 and 3 of the connector

Ramp Adjustment (Up, Down)

Notice: The factory setting of the ramp functions is to the minimum values.

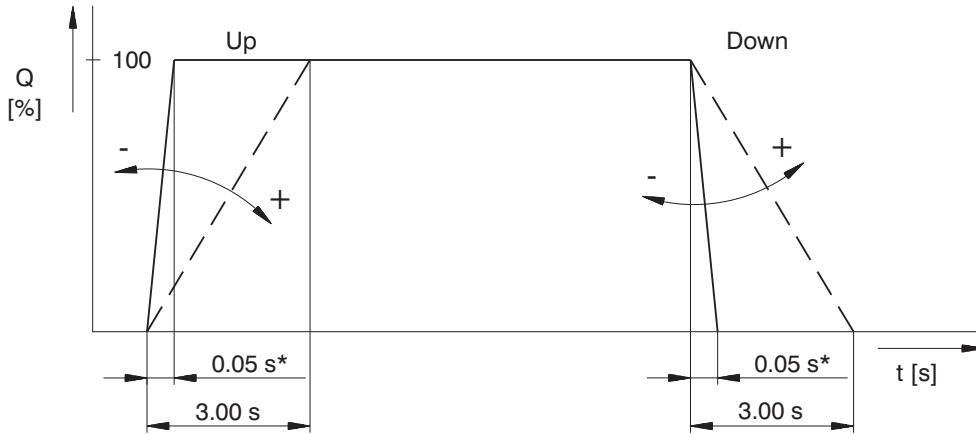

*The value has only an informative character with respect to the particular type of the proportional directional valve (see page 4)

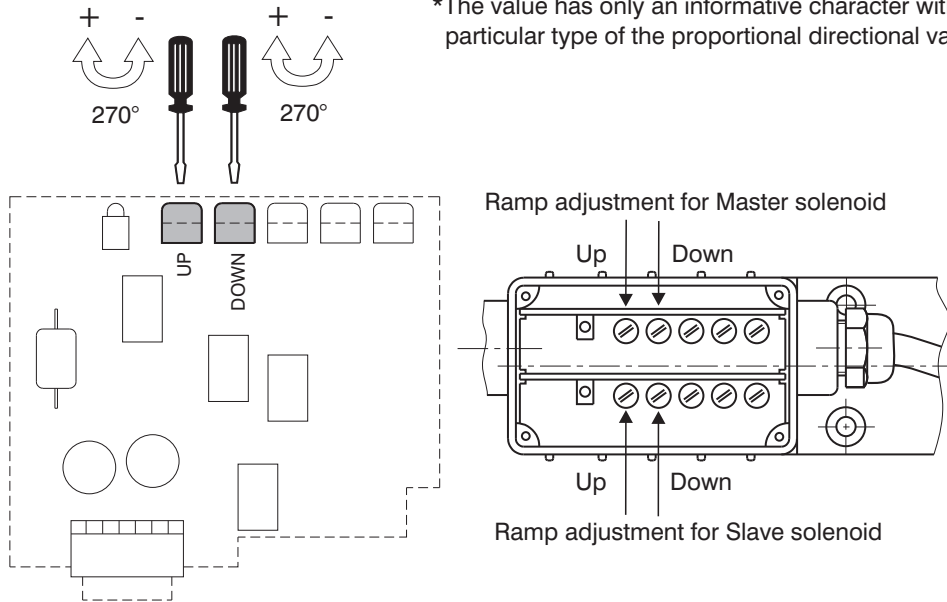

6

Dither Adjustment

Notice: The dither is adjusted with regard to the minimum hysteresis.

Amplitude - potentiometer (dither) (0 - 30 %)

Frequency - switch SW4

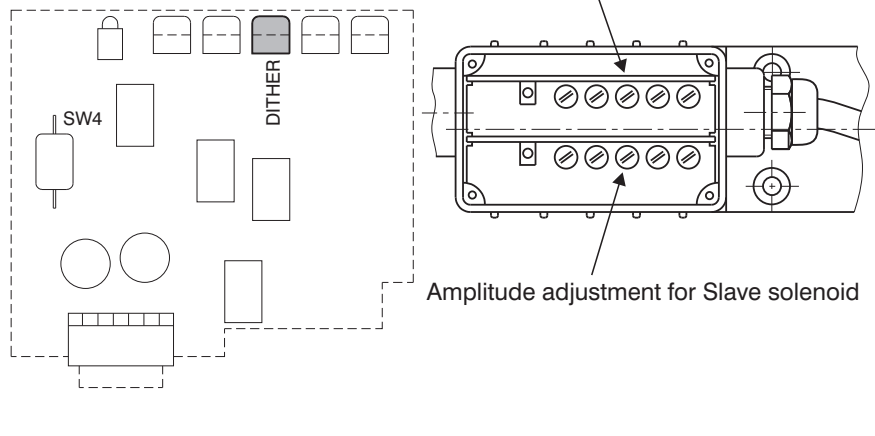
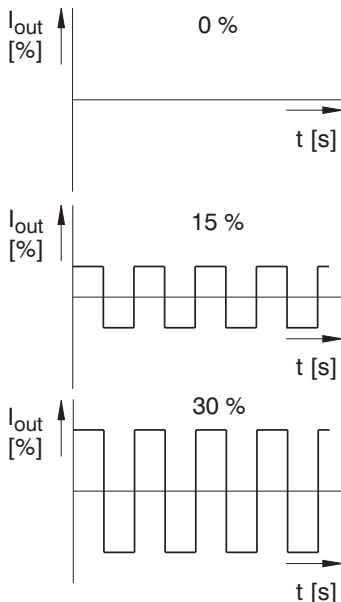

Adjustment of Offset, Gain Parameters

Notice: The factory setting of the Offset and Gain parameters is specific for the solenoids used. The manufacturer does not recommend this setting to be changed.

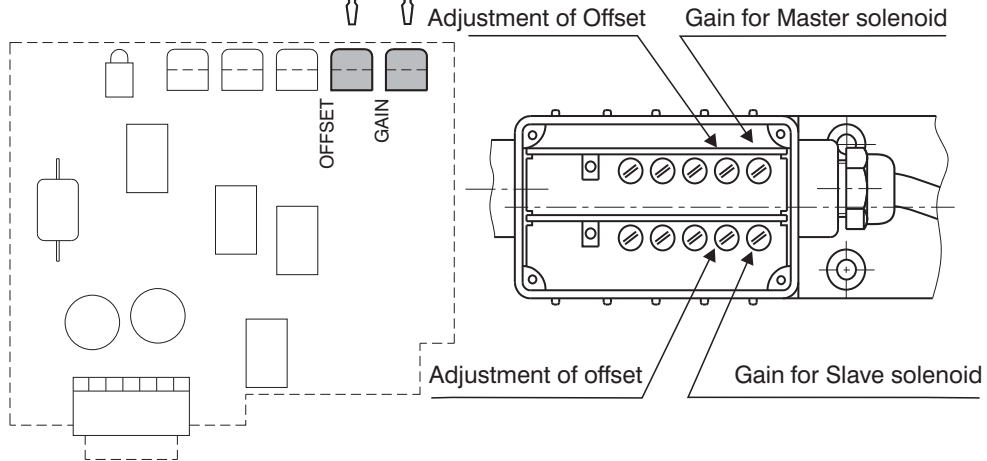
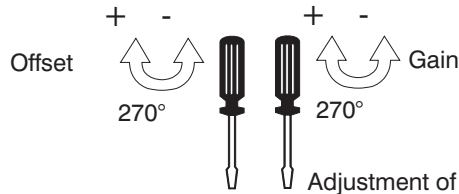
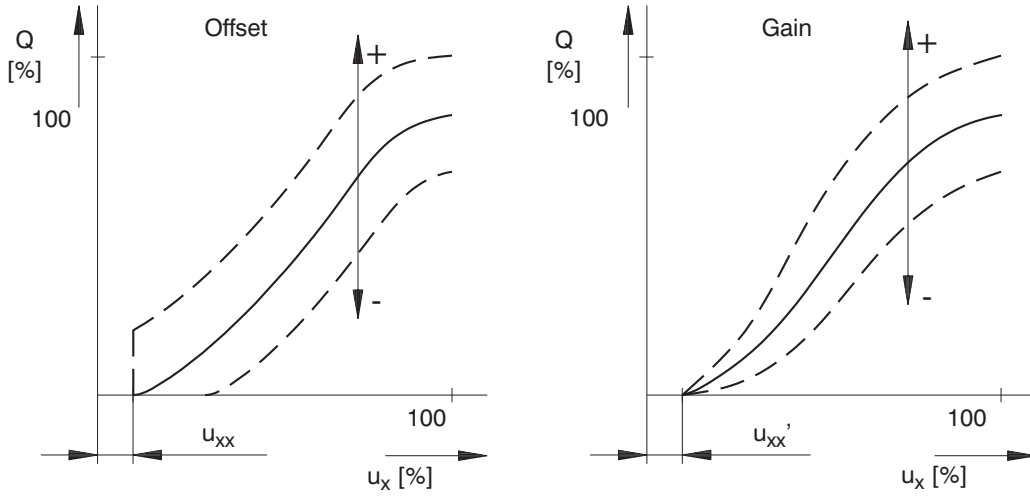

6

Nominal supply voltage of electronics [V]	Area insensible to control signal u_{xx} [%]
12	1 ... 3
24	0.5 ... 2

Valve Dimensions

Dimensions in millimetres

PRM2-042..../-....

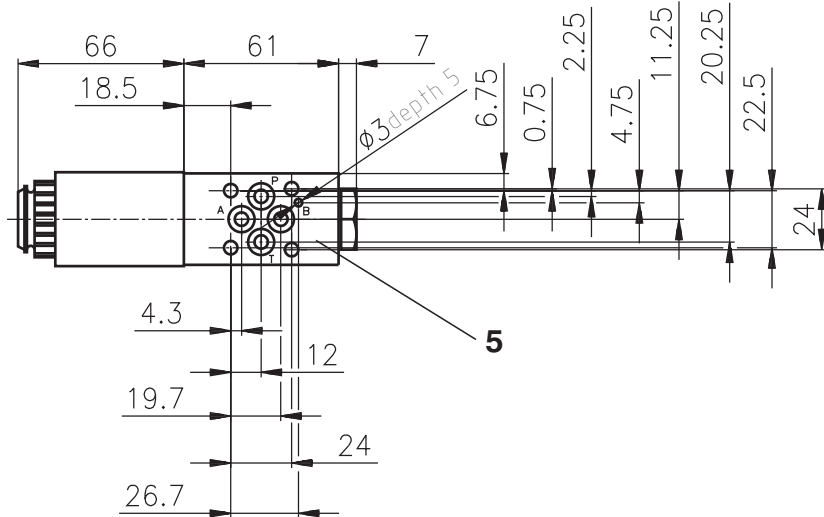

Functional symbols
2Z51, 2Y51

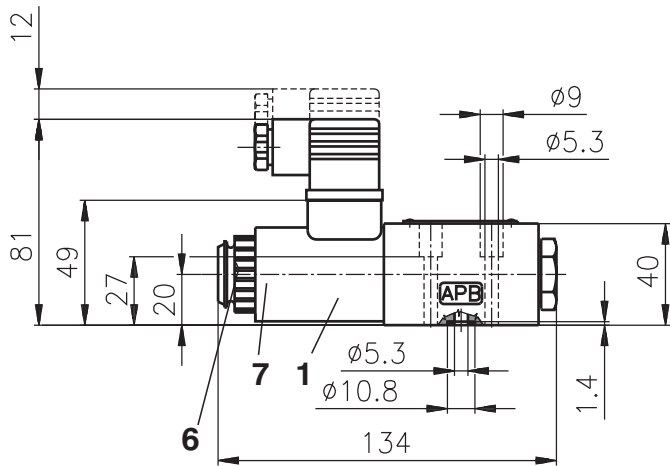

Functional symbols
2Z11, 2Y11

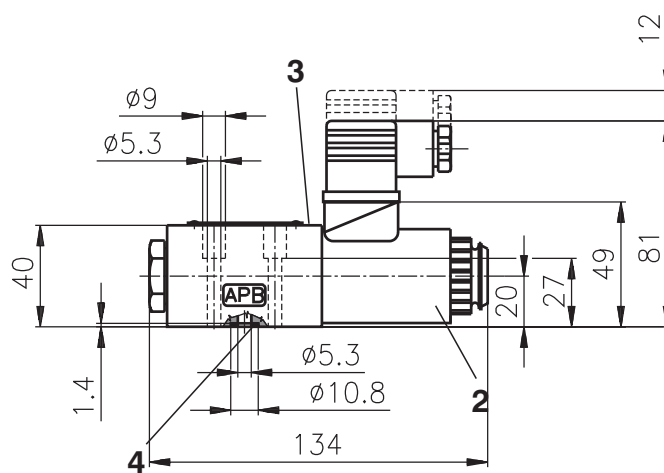

- 1 Solenoid a
- 2 Solenoid b
- 3 Name plate
- 4 Square ring 7.65 x 1.68 (4 pcs.)
supplied in delivery packet
- 5 4 mounting holes
- 6 Manual override
- 7 Solenoid fixing nut (Nut torque 3 Nm)

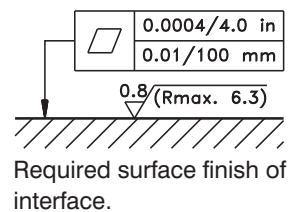

6

Valve Dimensions

Dimensions in millimetres

PRM2-043..../-....

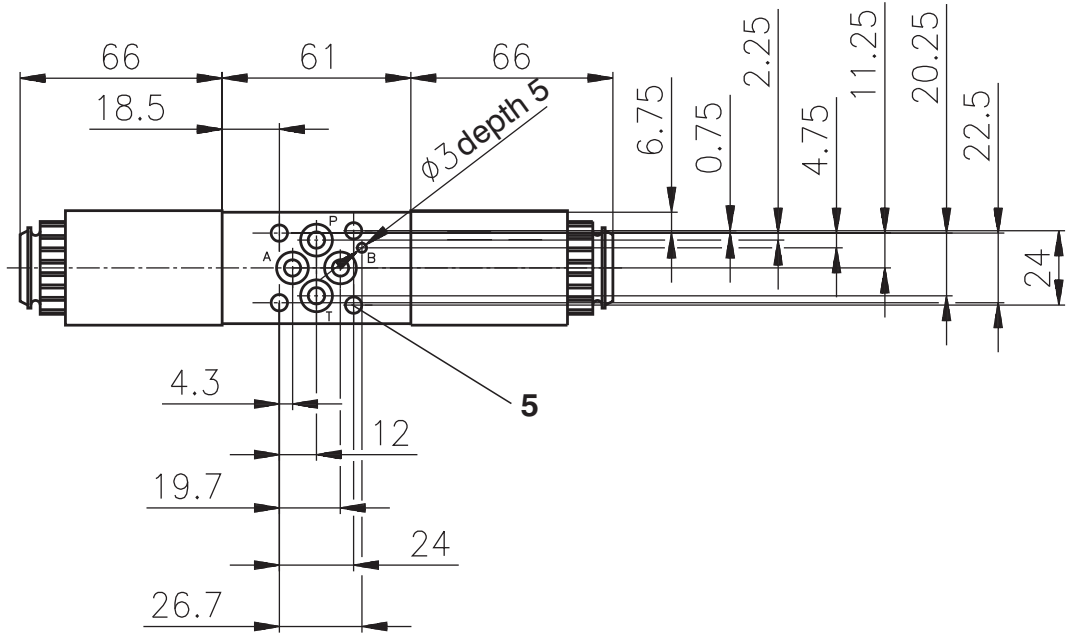

Functional symbols

3Z11, 3Z12, 3Y11, 3Y12

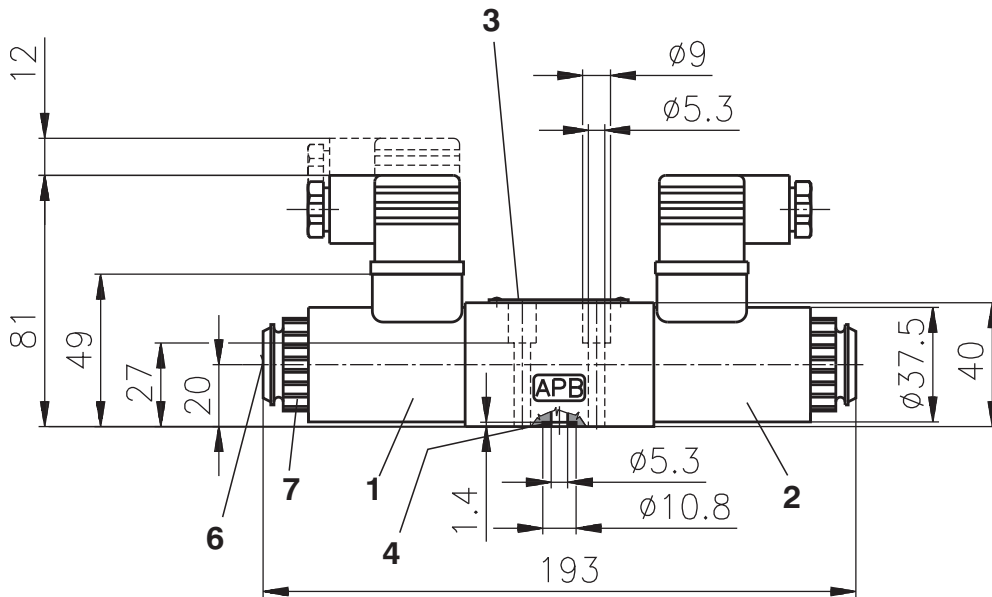

- 1 Solenoid a
- 2 Solenoid b
- 3 Name plate
- 4 Square ring 7.65 x 1.68 (4 pcs.)
supplied in delivery packet
- 5 4 mounting holes
- 6 Manual override
- 7 Solenoid fixing nut (Nut torque 3 Nm)

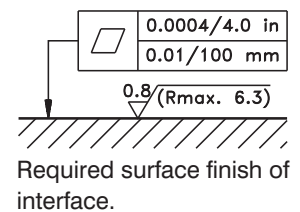

Valve Dimensions

Dimensions in millimetres

PRM2-042..../-...EK.

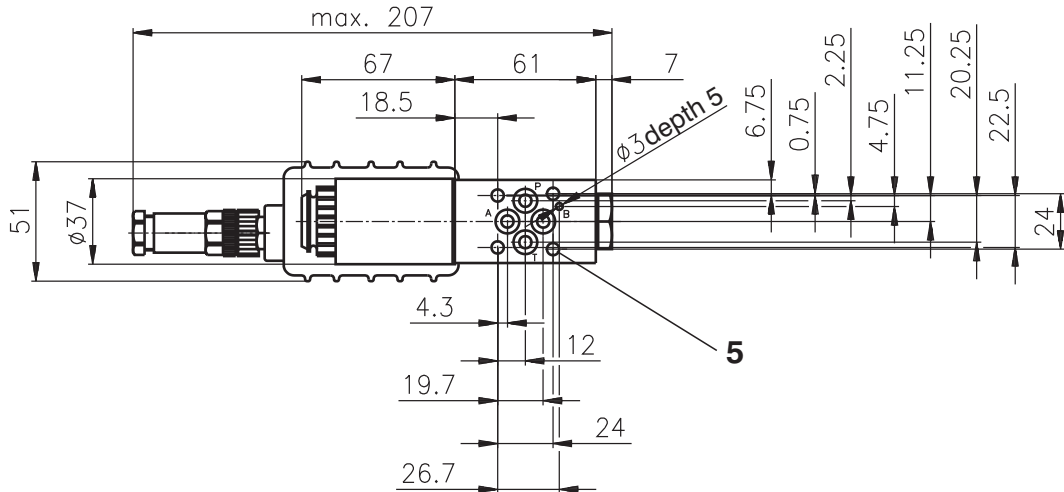

Functional symbols
2Z51, 2Y51

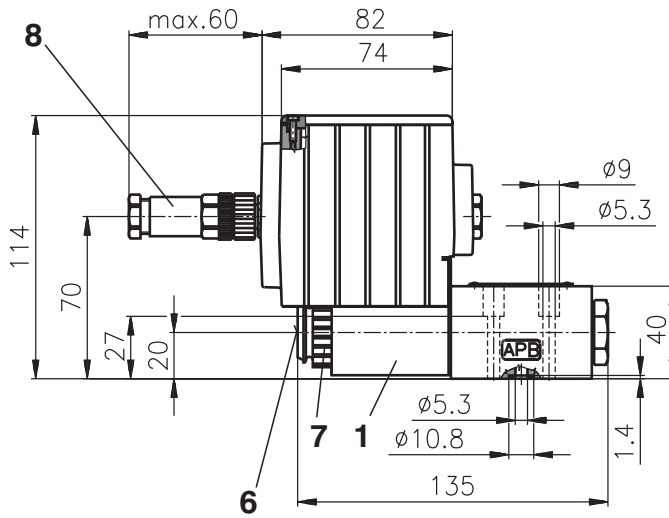

Functional symbols
2Z11, 2Y11

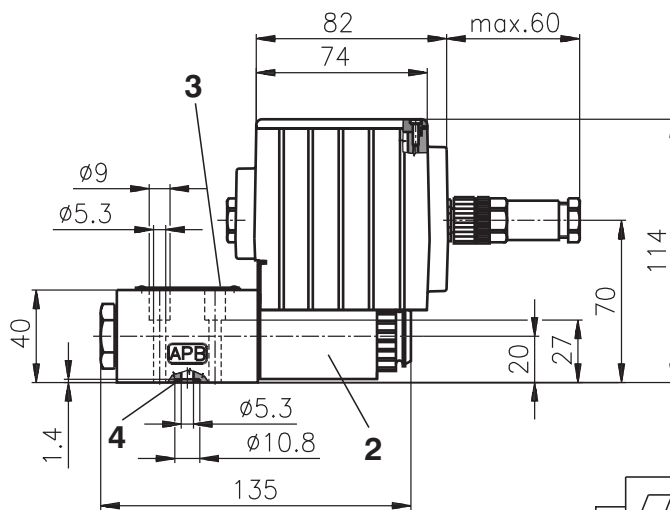

- 1 Solenoid a
- 2 Solenoid b
- 3 Name plate
- 4 Square ring 7.65 x 1.68 (4 pcs.)
supplied in delivery packet
- 5 4 mounting holes
- 6 Manual override
- 7 Solenoid fixing nut (Nut torque 3 Nm)
- 8 4-pin connector M12 x 1 for external supply voltage

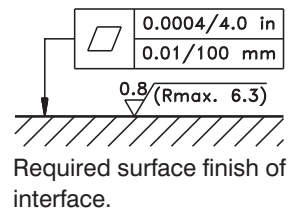

Valve Dimensions

Dimensions in millimetres

PRM2-043..../-...EK.

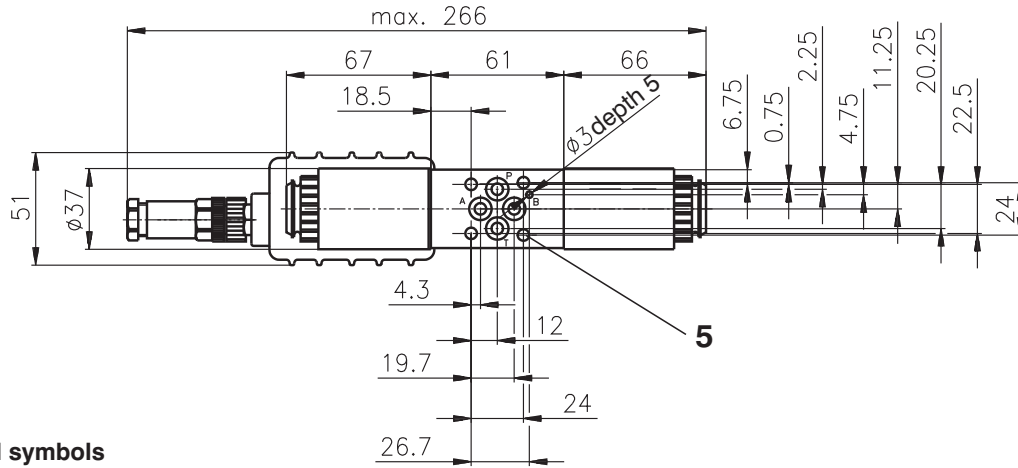

Functional symbols
3Z11, 3Z12, 3Y11, 3Y12

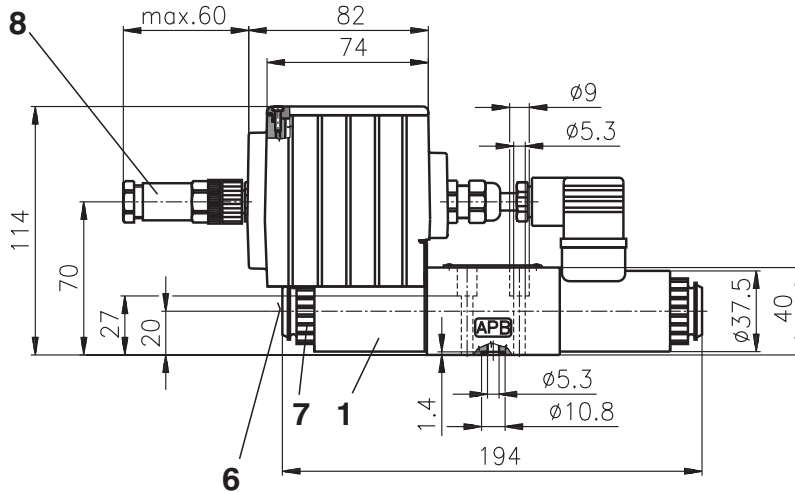

Functional symbols
3Z11B, 3Z12B, 3Y11B, 3Y12B

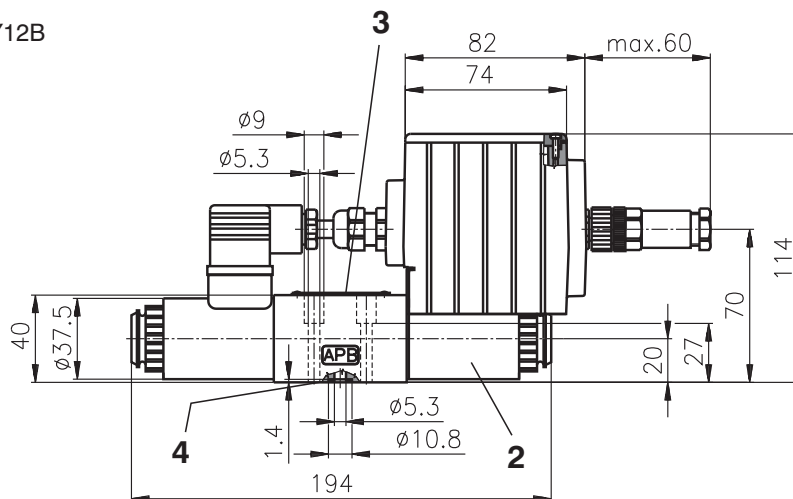

- 1 Solenoid a
- 2 Solenoid b
- 3 Name plate
- 4 Square ring 7.65 x 1.68 (4 pcs.)
supplied in delivery packet
- 5 4 mounting holes
- 6 Manual override
- 7 Solenoid fixing nut (Nut torque 3 Nm)
- 8 4- pin connector M12 x 1 for external supply voltage

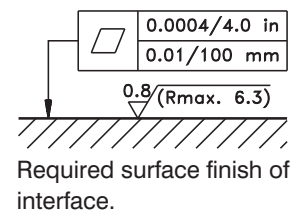

Spare Parts

- 1 Solenoid coil
- 2 Nut + sealing ring
- 3 Connector plug EN 175301-803
- 4 Set of seals
- 5 Fixing bolts
- 6 Connector

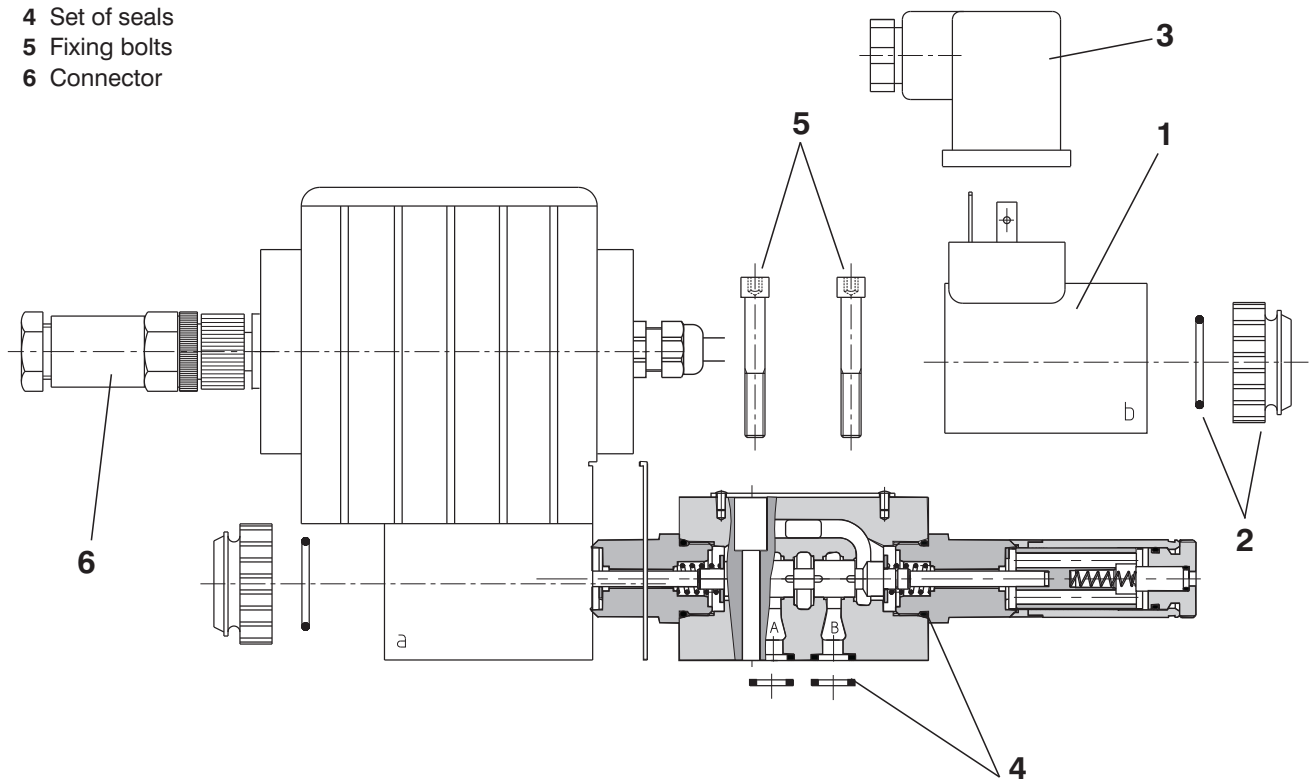

1. Solenoid coil

Nominal supply voltage [V]	Ordering number
12	16186100
24	16186200

2. Solenoid fixing nut + sealing ring

Model of the nut	Sealing ring	Ordering number
Standard nut	18 x 1,5	15874500

3. Connector plug to EN 175301-803

Type designation	Type	Maximum input voltage	Connector plug A gray	Connector plug B black
			Ordering number	
K5	without rectifier - M16x1.5, (bushing bore \varnothing 4-6 mm)	230 V DC	16202600	16202500

4. Set of seals

Type	Dimensions, number		Ordering number
Standard - NBR 70	7.65 x 1.68 (4 pcs)	16 x 2 (2 pcs)	15873800
Viton	7.65 x 1.68 (4 pcs)	16 x 2 (2 pcs)	15874400

5. Fixing bolts - set

Dimensions, number	Tightening torque	Ordering number
M5 x 35 DIN 912-10.9 (4 pcs)	5 Nm	15874600

6. Connector

Ordering number
M12 x 1 (4-pin connector) 358358904012

Caution!

- The packing foil is recyclable.
- The protective plate can be returned to manufacturer.
- Mounting bolts M5 x 35 DIN 912-10.9 or studs must be ordered separately.
Tightening torque of the bolts is 5 Nm.
- The technical information regarding the product presented in this catalogue is for descriptive purposes only. It should not be construed in any case as a guaranteed representation of the product properties in the sense of law.

ARGO-HYTOS s.r.o. CZ - 543 15 Vrchlabí
Tel.: +420-499-403111, Fax: +420-499-403421
E-mail: sales.cz@argo-hytos.com
www.argo-hytos.com

- Compact design with integrated
- High reliability
- Simple replacement of the exciting coils including electronics without opening the hydraulic circuits
- Continuous flow control in both directions
- Installation dimensions to DIN 24 340 / ISO 4401 / CETOP RP121-H

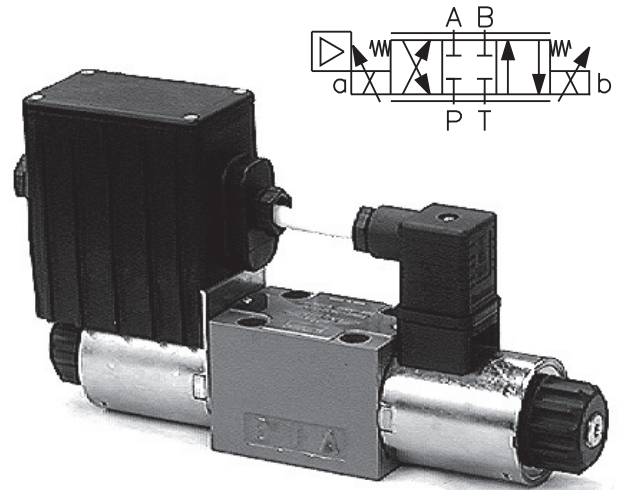

Functional Description

The proportional directional valve consists of a cast-iron housing, a special control spool, two centering springs with supporting washers and one or two proportional solenoids. A control box, which comprises one or two electronic control cards, depending on the number of the controlled solenoids, can be mounted onto either solenoid. With the model with two solenoids, the solenoid mounted apposite the control box is connected with the box by means of a DIN connector, a two-cored cable and a bushing. The connection of the control box with the supply source and with the control signal is realized by means of a 4-pin connector, type M12 x 1. The solenoid coils, including the control box, can be turned in the range of $\pm 90^\circ$. The electric control unit supplies the solenoid with current, which varies with the control signal. The solenoid shifts the control spool to the required position, proportional to the control current.

The electronic control unit provides the following adjustment possibilities: Offset, Gain, rise and drop-out time of the ramp generator, frequency (2 frequencies) and amplitude of the dither signal generator. The correct function of the control unit is signaled by LED-diodes. Stabilized voltage +10V (+5V for voltage 12V) is also available for the user. By the use of this voltage, a voltage control signal can be made by means of a potentiometer $\geq 1 \text{ k}\Omega$.

The electronic control card enables voltage or current control to be used, according to the positions of the switches SW1 to SW3 (see table on page 6).

The basic surface treatment of the valve housing is phosphate coated, the operating solenoids are zinc coated.

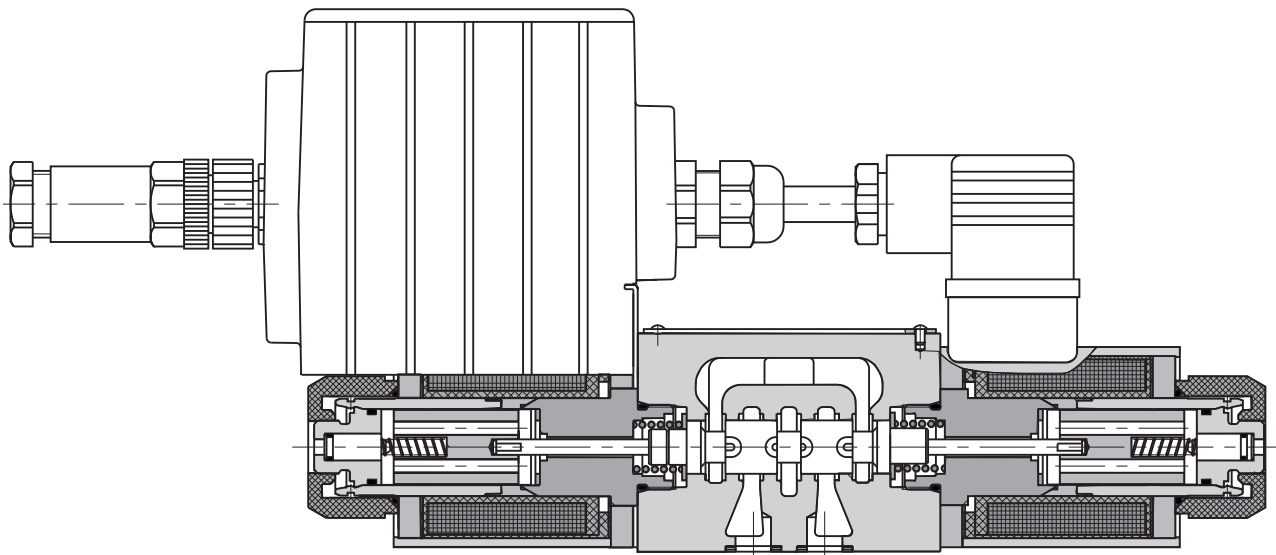

Ordering Code

PRM2-06 / -

Proportional Directional Control Valve

Seals

without designation
V

NBR
FPM (Viton)

Nominal size

Electronics

without designation without electronics

EK

connection by connector
M12 x 1 (4-pin connector)
(supplied with counterpart)

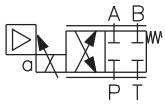

2Z51

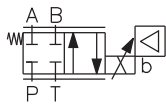

2Z11

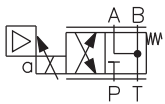

2Y51

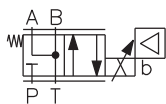

2Y11

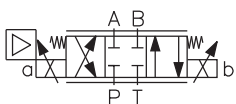

3Z11

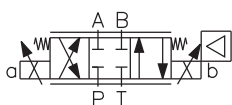

3Z11B

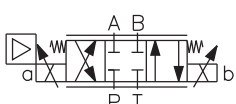

$$\frac{q_A}{q_B} = \frac{1}{2}^*$$

3Z12

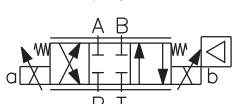

$$\frac{q_A}{q_B} = \frac{1}{2}^*$$

3Z12B

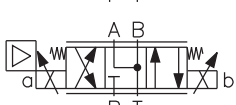

3Y11

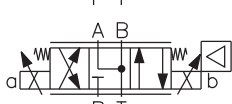

3Y11B

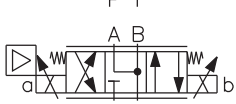

$$\frac{q_A}{q_B} = \frac{1}{2}^*$$

3Y12

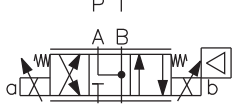

$$\frac{q_A}{q_B} = \frac{1}{2}^*$$

3Y12B

Nominal supply voltage

12
24

12 V DC
24 V DC

Nominal flow rate at Δp = 10 bar

15
30

15 L/min
30 L/min

* Model for cylinders with asymmetric piston rod, piston area ratio 1:2

Technical Data

Nominal size	mm	06
Maximum operating pressure at ports P, A, B	bar	350
Maximum operating pressure at port T	bar	210
Hydraulic fluid	Hydraulic oils of power classes (HL, HLP) to DIN 51524	
Fluid temperature range (NBR / Viton)	°C	-30 ... +80 / -20 ... +80
Ambient temperature, max.	°C	+50
Viscosity range	mm ² /s	20 ... 400
Maximum degree of fluid contamination	Class 21/18/15 according to ISO 4406	
Nominal flow rate Q_n at $\Delta p = 10$ bar ($v = 32 \text{ mm}^2 \cdot \text{s}^{-1}$)	L/min	15 / 30
Hysteresis	%	≤ 6
Weight PRM2-062 PRM2-063	kg	1.9 2.40
Mounting position	unrestricted, preferably horizontal	
Enclosure type EN 60 529	IP65	

Technical Data of the Proportional Solenoid

Type of coil	V	12 DC		24 DC
Limit current	A	2.5	1.6 (12 V electronic)	1.0
Resistance at 20 °C	Ω	2.3	5.2 (12 V electronic)	13.4

Technical Data of the Electronics

Nominal supply voltage U_{cc}	V	12 DC	24 DC
Supply voltage range	V	11.2 ... 14.7	20 ... 30 DC
Stabilized voltage for control	V	5 DC ($R > 1k\Omega$)	10 DC ($R \geq 1k\Omega$)
Control signal	see table of switches configuration (page 6)		
Maximum output current	A	2.4 for $R < 4\Omega$	1.5 for $R < 10\Omega$
Ramp adjustment range	s	0.05 ... 3	
Dither frequency	Hz	90/60	
Dither amplitude	%	0 ... 30	

Limit power

Measured at $v = 32 \text{ mm}^2/\text{s}$

P → A / B → T or P → B / A → T

Nominal flow 15 L/min

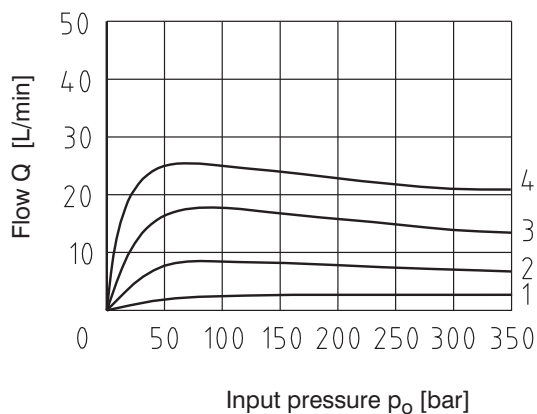

Nominal flow 30 L/min

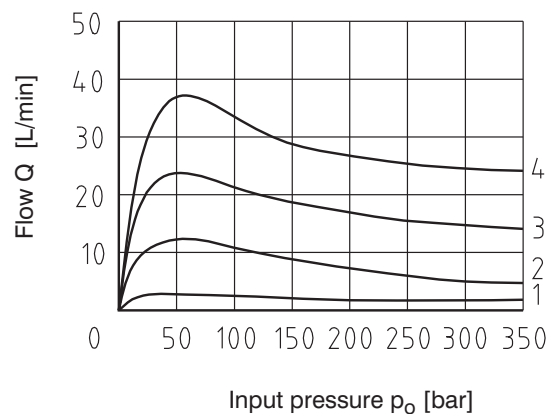

Solenoid current:

- 1 = 40%
- 2 = 60%
- 3 = 80%
- 4 = 100%

Flow Characteristic with Integrated Electronics

Measured at $\Delta p = 10 \text{ bar}$, $v = 32 \text{ mm}^2/\text{s}$

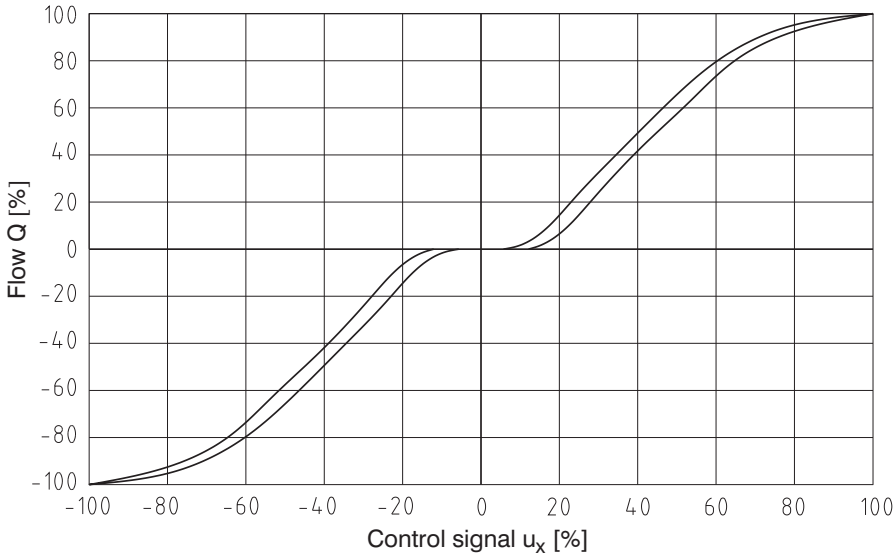

Flow Characteristic without Integrated Electronics

Measured at $\Delta p = 10 \text{ bar}$, $v = 32 \text{ mm}^2/\text{s}$,

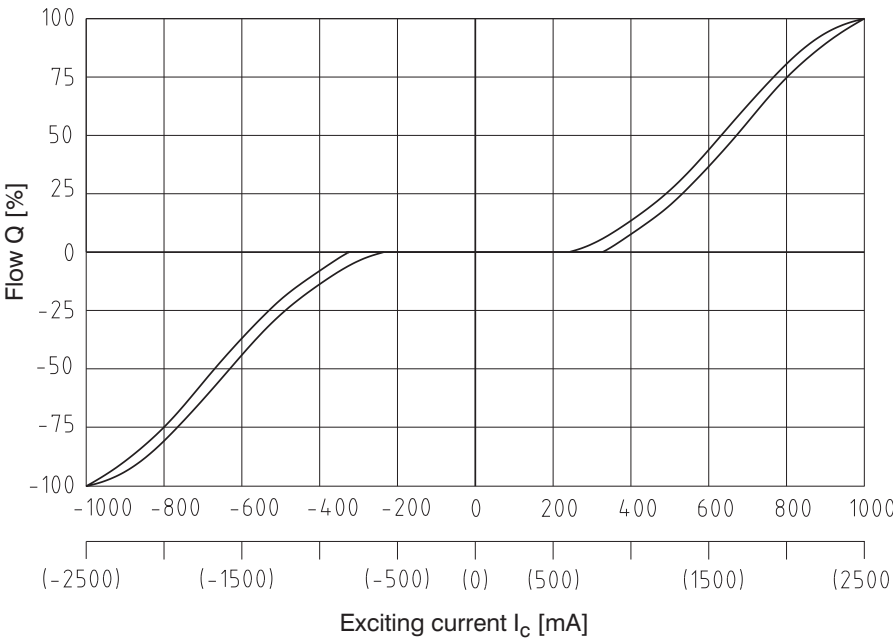

Values in parenthesis are valid for the supply voltage 12 V

The coil current which initializes the flow through the proportional directional valve can differ due to the production tolerances about in a range of $\pm 6\%$ of the limit current.

Transient Characteristic

Measured at $\Delta p = 10 \text{ bar}$, $v = 32 \text{ mm}^2/\text{s}$; $Q = 80\%Q_n$

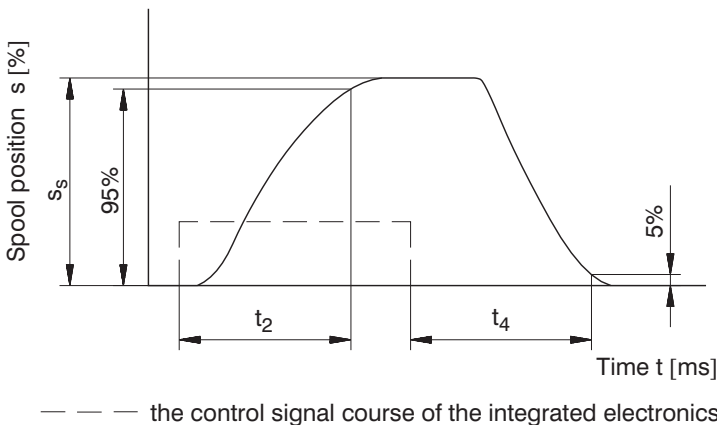

Steady spool position s_s [%]	t_2 [ms]	t_4 [ms]
100	85	100
75	70	85
50	55	75
25	45	55

The values in table have only an informative character.

The times of the transient characteristics at pressure or flow control will be in a particular hydraulic circuit always longer.

Frequency Reponse

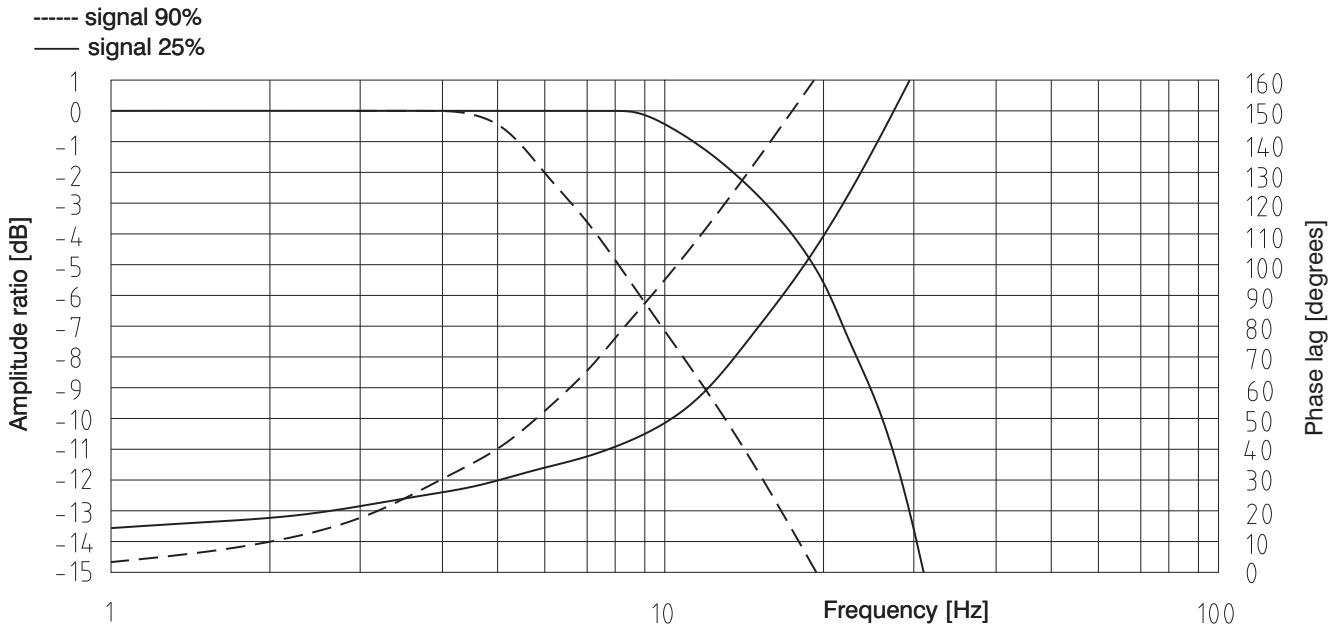

Component Arrangement on the Electronic Card

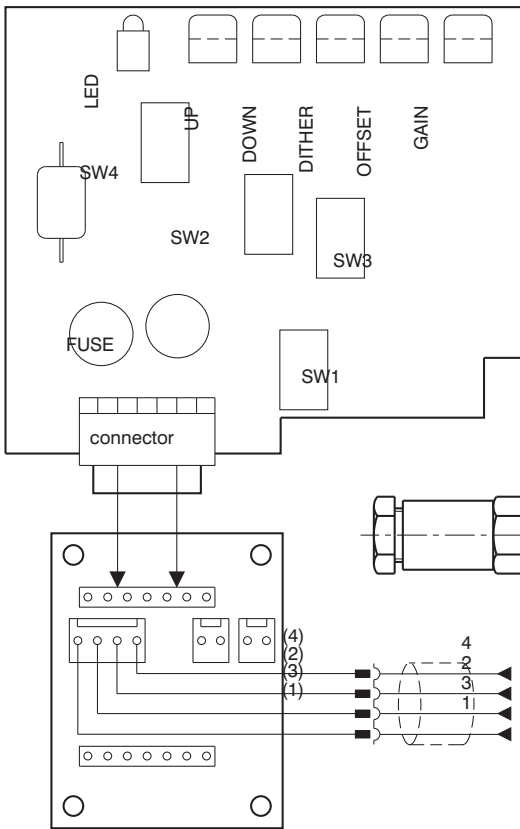

- SW1 - control signal choice
- SW2 - control signal choice
- SW3 - control signal choice
- SW4 - dither frequency

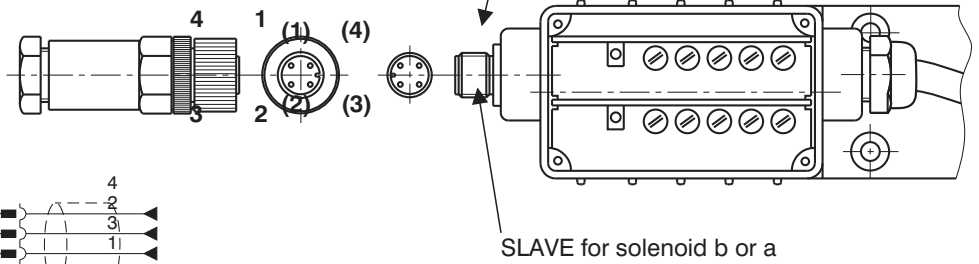

Description basic subplatte

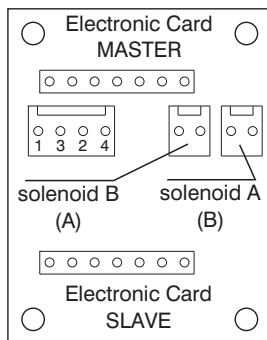

PIN	Description
1	+24 V (U_{cc}) (+12 V)
2	control
3	0 V
4	+10 V (+5 V)

6

Table of the Switch Configuration for the Control Signal Choices

		PRM2-062				PRM2-063	
		0 ... 5 V	0 ... 10 V (0 ... 5 V)*	0 ... 20 mA	4 ... 20 mA	$U_{cc}/2$ $\pm 10 V (\pm 5 V)^*$	$\pm 10 V$ $(\pm 5 V)^*$
MASTER M	SW1						
	SW2						
	SW3						
	SW4	90 Hz			60 Hz		
SLAVE S	SW1	X					
	SW2						
	SW3						
	SW4					90 Hz	

6

Designation of the basic manufacture setting.



The ramp functions are adjusted on their minimum values, the dither is set to the optimal value with respect to hysteresis. Offset and Gain are adjusted according to the characteristic on page 3 and 4. The manufacturer does not recommend these adjusted values to be changed.

* Input signal level for the 12 V electronic unit.

Block Diagram

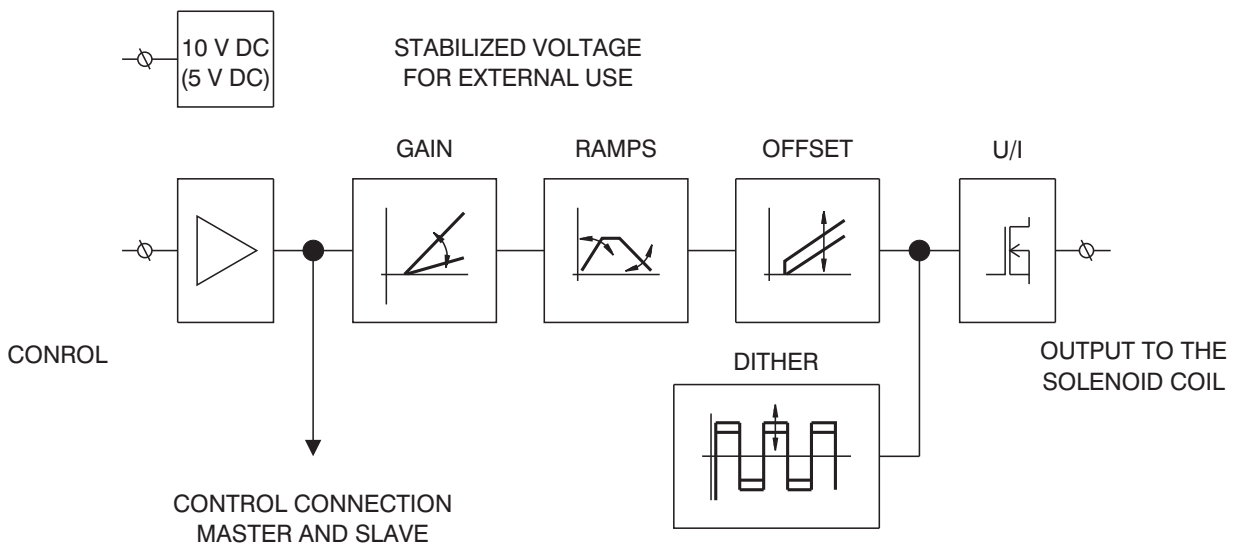

Valve PRM2-062 (with one solenoid)

1 Factory setting

1.1 Control with external voltage source 0 ... 10 V (0 ... 5 V) or with external potentiometer R > 1 kΩ

Notice:

The control signal must have the same ground potential as the supply source.

Master card for solenoid a (b)

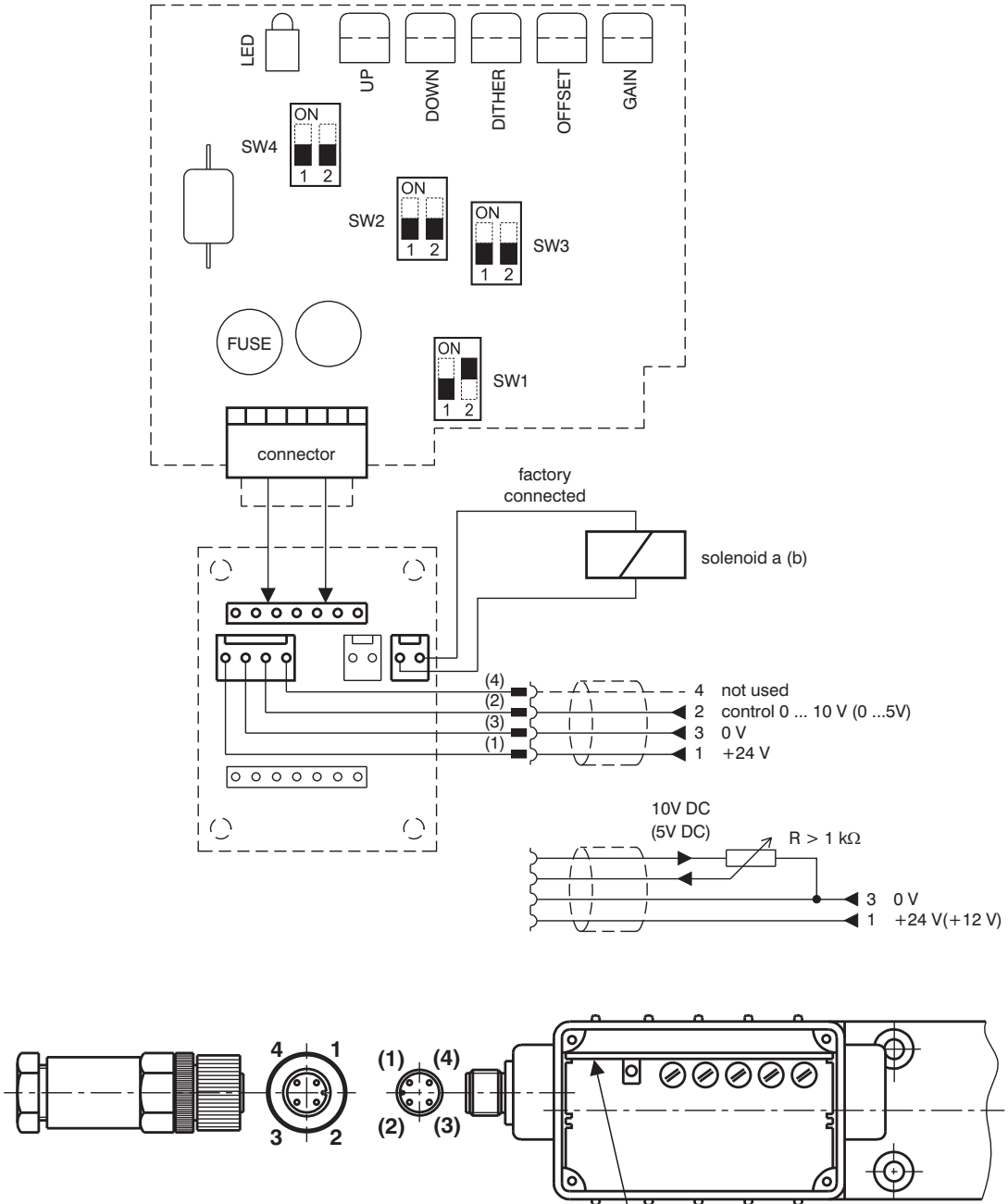

Wire colours (connection connector - electronics):

- (1) - brown
- (2) - white
- (3) - blue
- (4) - black

Factory set values:

Control signal: 0 - 10 V (0 - 5V)

Dither: frequency 90Hz
amplitude - optimum

Ramps: 0.05 s

Offset, Gain: according to the characteristics on page 3, 4

Valve PRM2-062 (with one solenoid)

2 Other control possibilities

2.1 Control with external source 0 ... 5 V

Notice:

The control signal must have the same ground potential as the supply source.

Master card for solenoid a (b)

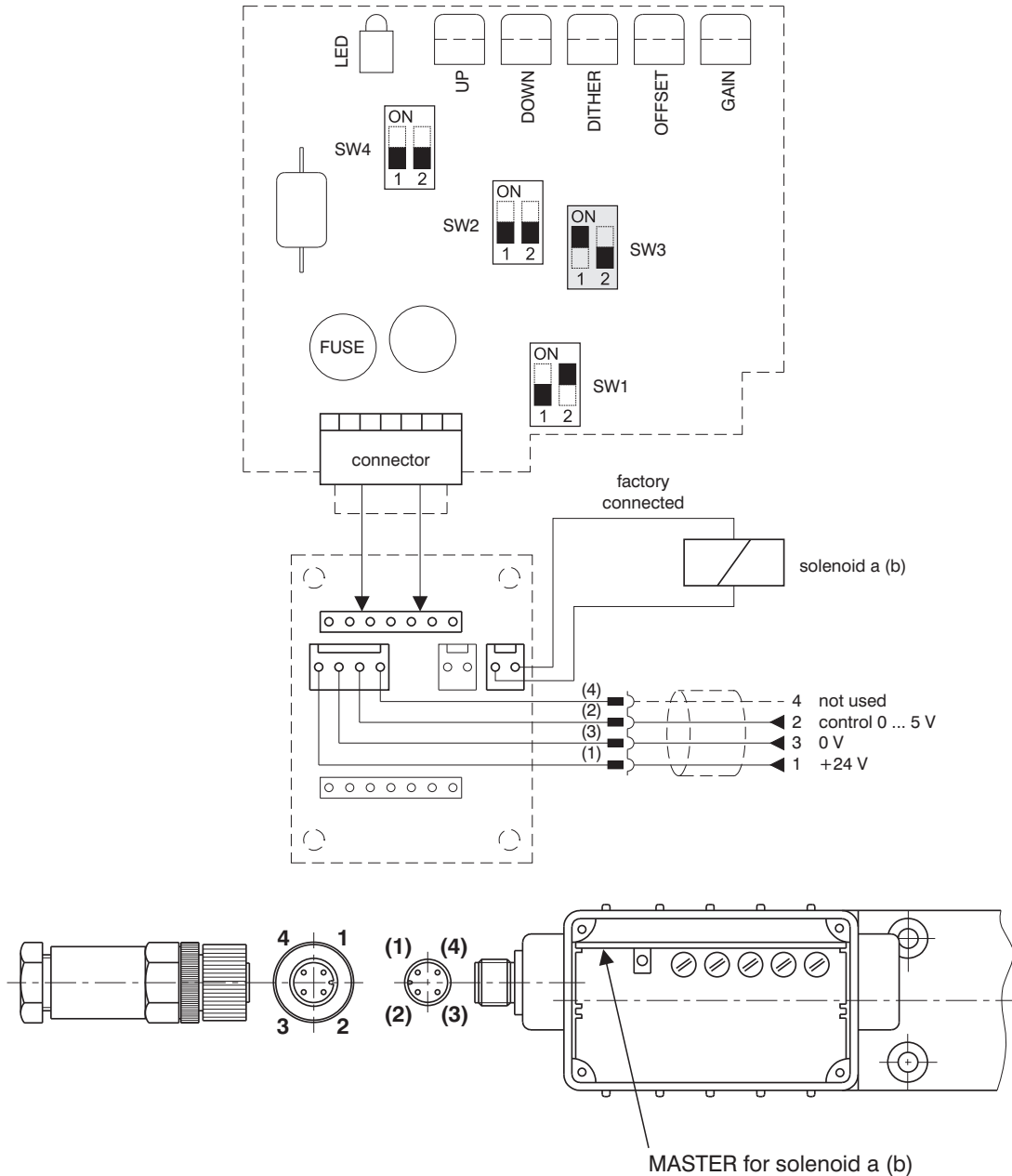

For the factory setting modification for this case of application, the following steps are required:

1. Unscrew the electronics cover
2. Carefully remove the Master card
3. Flip the switch SW3 in position shown in the picture
4. Put in the Master card and fix the electronics cover
5. Connect the voltage +24 V from an external supply source to terminals 1 and 3 of the connector
6. Connect the control voltage 0 ... 5 V from an external source to terminals 2 and 3 of the connector

Valve PRM2-062 (with one solenoid)

2.2 Control with external source 0 ... 20 mA

Notice:

The control signal must have the same ground potential as the supply source.

Master card for solenoid a (b)

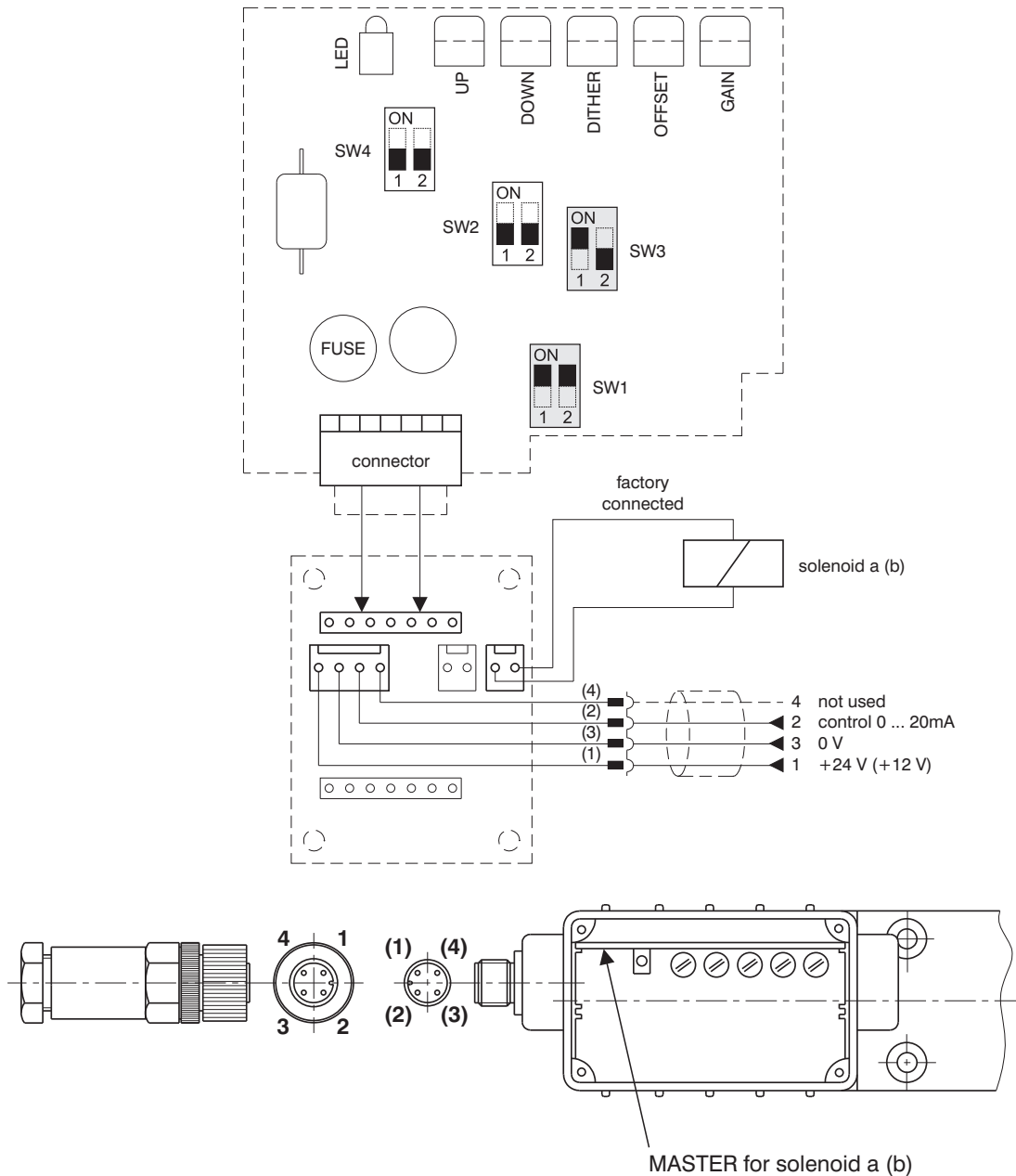

For the factory setting modification for this case of application, the following steps are required:

1. Unscrew the electronics cover
2. Carefully remove the Master card
3. Flip the switch SW1 and SW3 in position shown in the picture
4. Put in the Master card and fix the electronics cover
5. Connect the voltage +24 V (+12 V) from an external supply source to terminals 1 and 3 of the connector
6. Bring the control current 0 ... 20 mA from an external source to terminals 2 and 3 of the connector

Valve PRM2-062 (with one solenoid)

2.3 Control with external source 4 ... 20 mA

Notice:

The control signal must have the same ground potential as the supply source.

Master card for solenoid a (b)

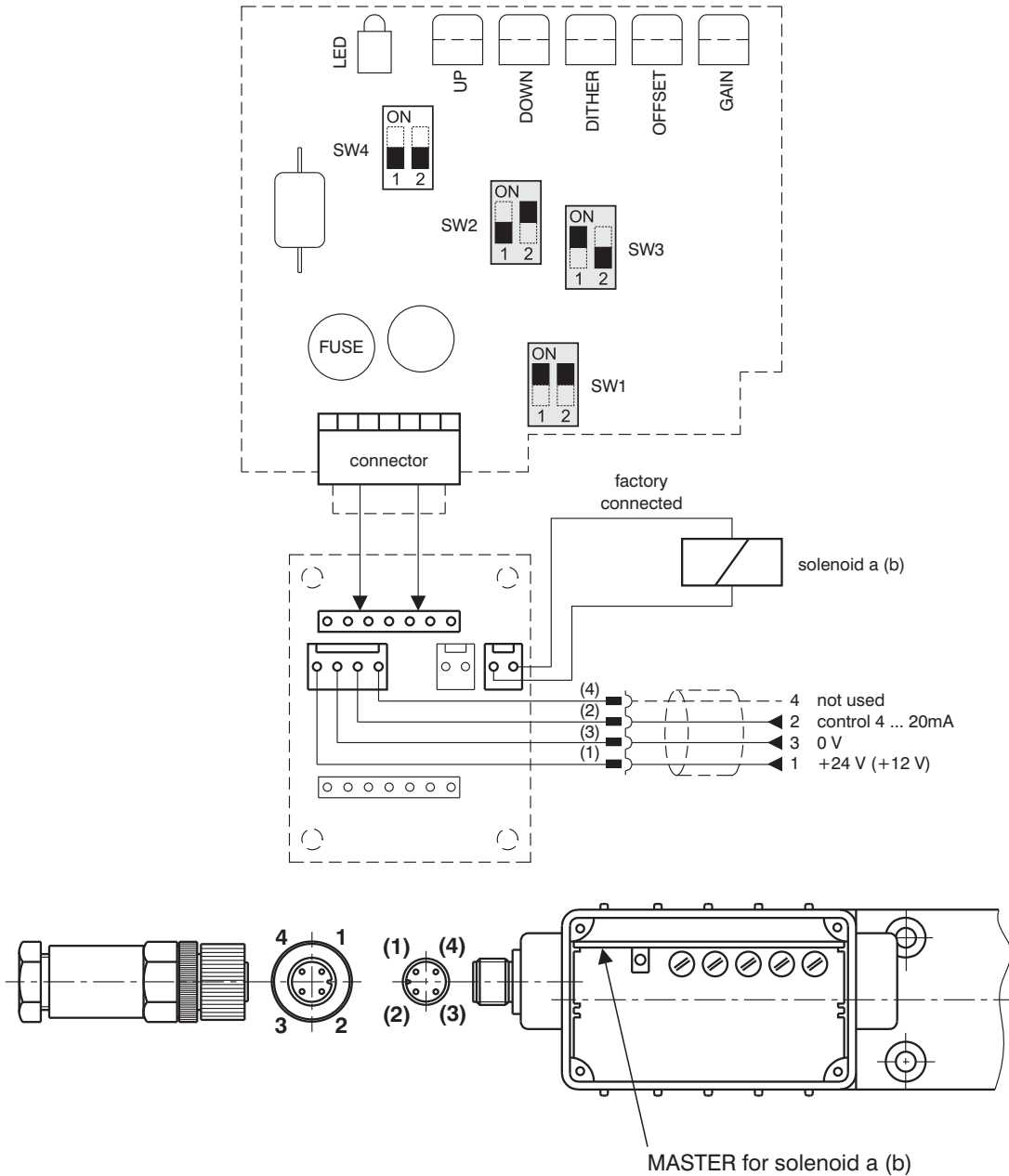

For the factory setting modification for this case of application, the following steps are required:

1. Unscrew the electronics cover
2. Carefully remove the Master card
3. Flip the switch SW1, SW2 and SW3 in position shown in the picture
4. Put in the Master card and fix the electronics cover
5. Connect the voltage +24 V (+12 V) from an external supply source to terminals 1 and 3 of the connector
6. Bring the control current 4 ... 20 mA from an external source to terminals 2 and 3 of the connector

Valve PRM2-063 (with two solenoids)

3 Factory setting

3.1 Control with external source $0 \pm 10 \text{ V}$ ($0 \pm 5 \text{ V}$)

Notice:

The control signal must have the same ground potential as the supply source.

Master card for solenoid a (b)

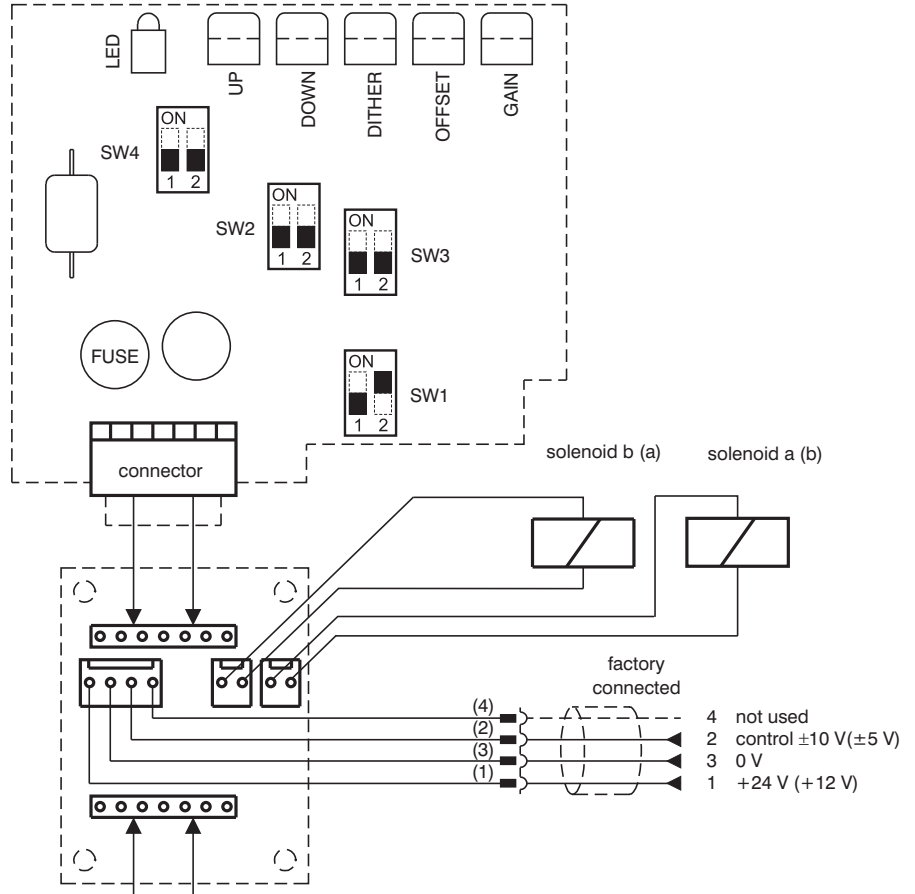

Slave card for solenoid b (a)

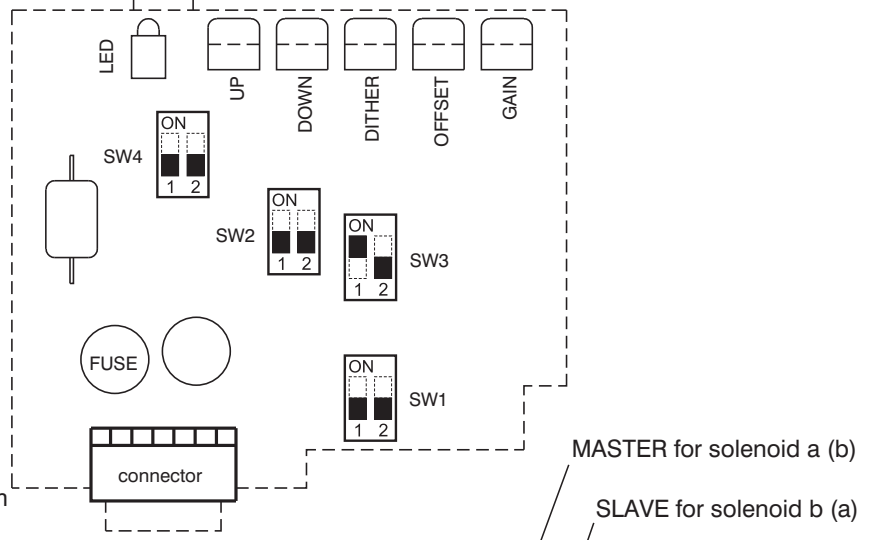

Factory set values:

Control signal: $0 \pm 10 \text{ V}$ ($0 \pm 5 \text{ V}$)

Dither: frequency 90 Hz
amplitude - optimum

Ramps: 0.05 s

Offset, Gain: according to the characteristics on page 3, 4

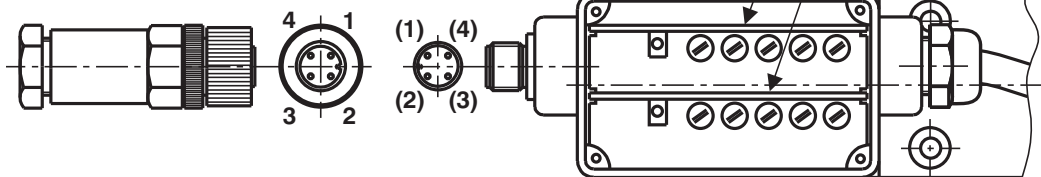

6

Valve PRM2-063 (with two solenoids)

3.2 Other control possibilities

Control $U_{cc}/2 \pm 10 V (U_{cc}/2 \pm 5V)$ external potentiometer $R > 1 k\Omega$

Master card for solenoid a (b)

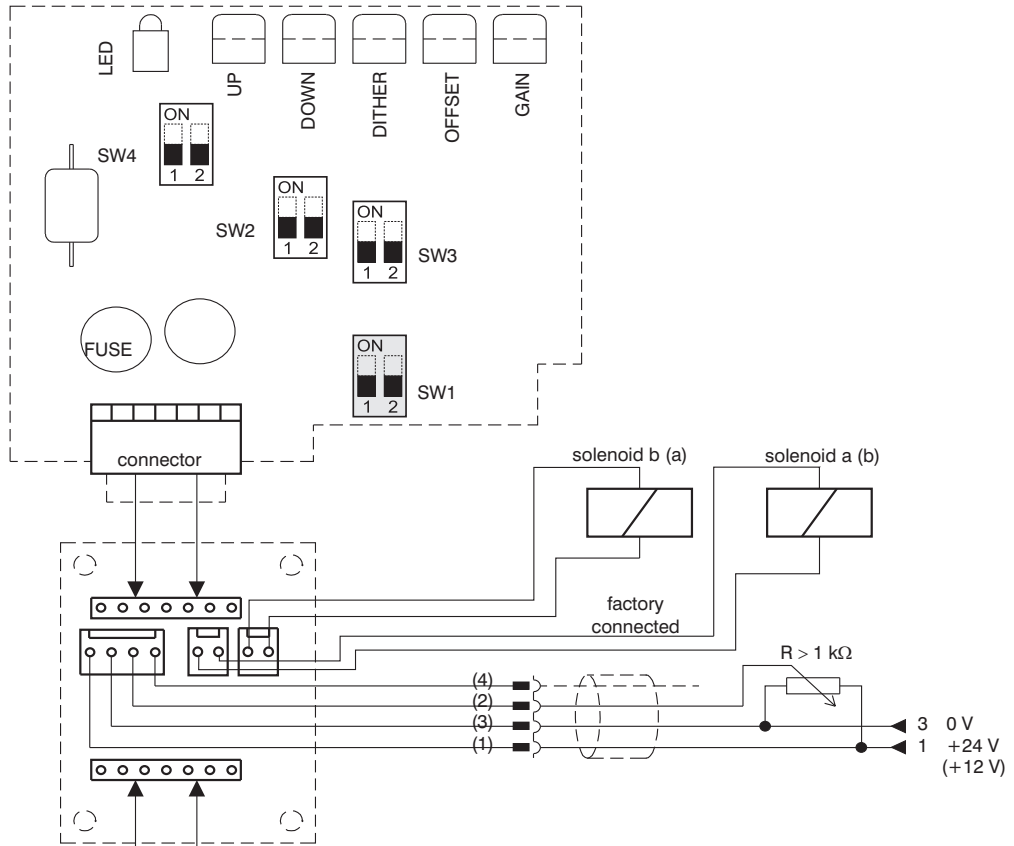

Slave card for solenoid b (a)

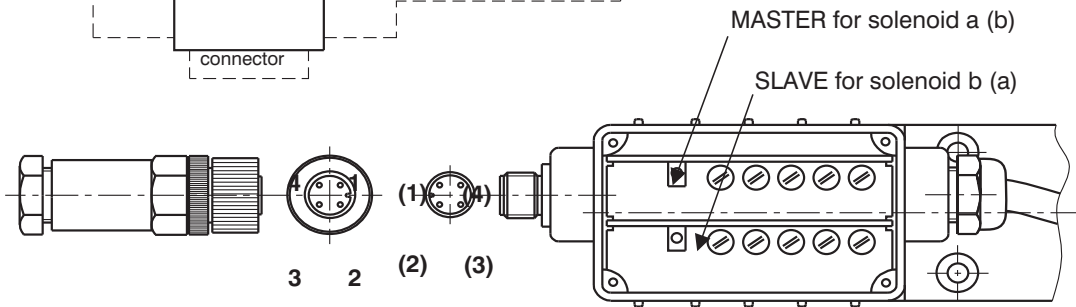
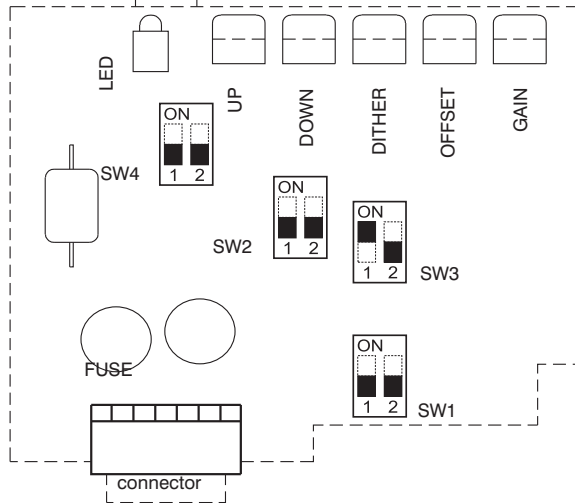

For the factory setting modification for this case of application, the following steps are required:

1. Unscrew the electronics cover
2. Carefully remove the Master card
3. Flip the switch SW1 in position shown in the picture
4. Put in the Master card and fix the electronics cover
5. Connect the voltage +24 V (+12 V) from an external supply source to terminals 1 and 3 of the connector

Ramp Adjustment (Up, Down)

Notice: The factory setting of the ramp functions is to the minimum values.

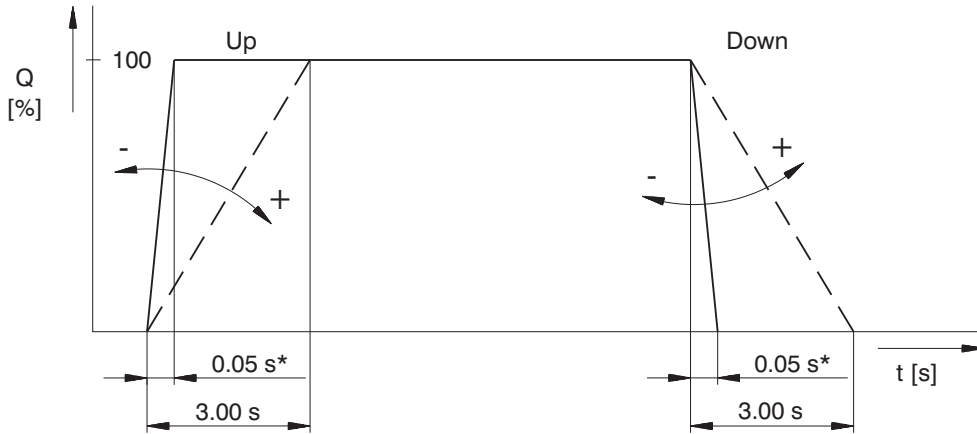

*The value has only an informative character with respect to the particular type of the proportional directional valve (see page 4)

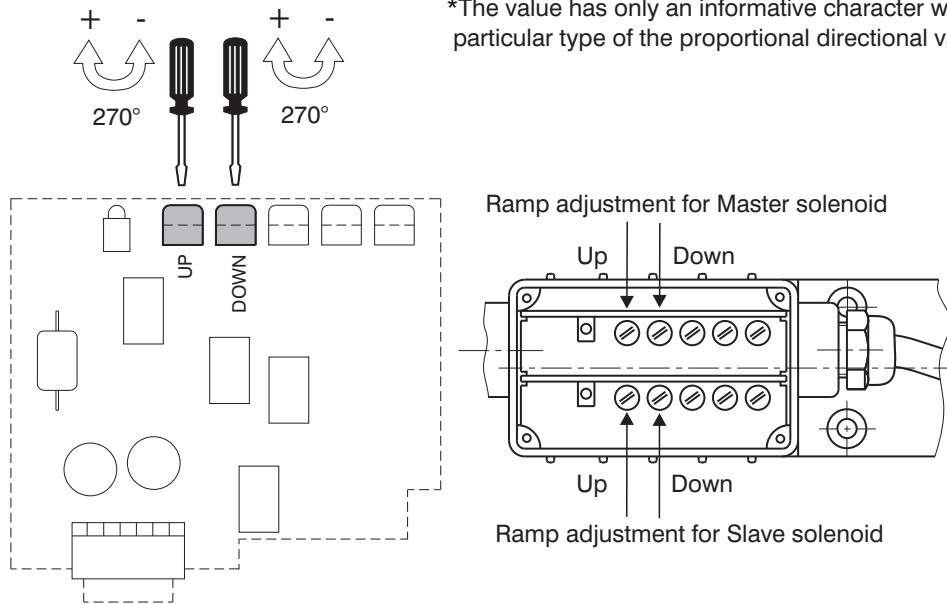

Dither Adjustment

Notice: The dither is adjusted with regard to the minimum hysteresis.

Amplitude - potentiometer (dither) (0 - 30 %)

Frequency - switch SW4

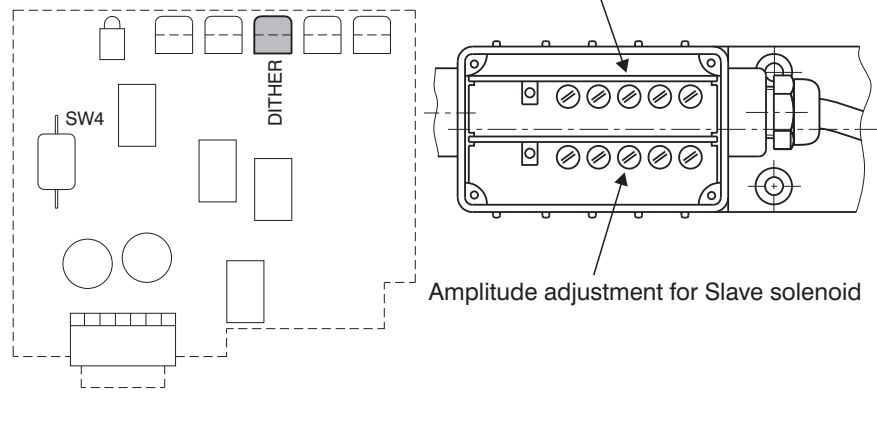
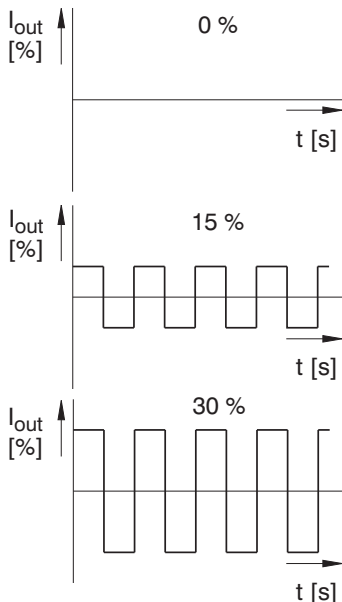

Adjustment of Offset, Gain Parameters

Notice: The factory setting of the Offset and Gain parameters is specific for the solenoids used. The manufacturer does not recommend this setting to be changed.

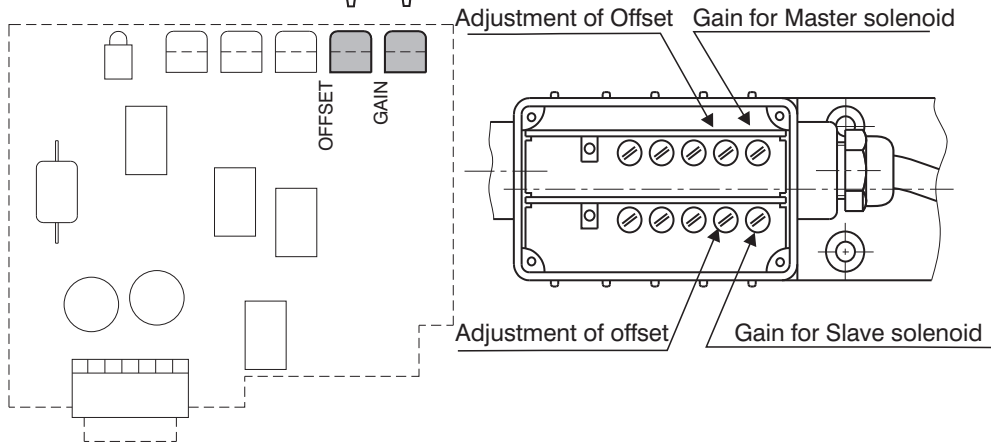
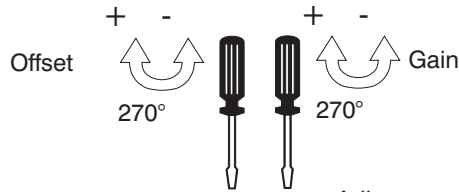
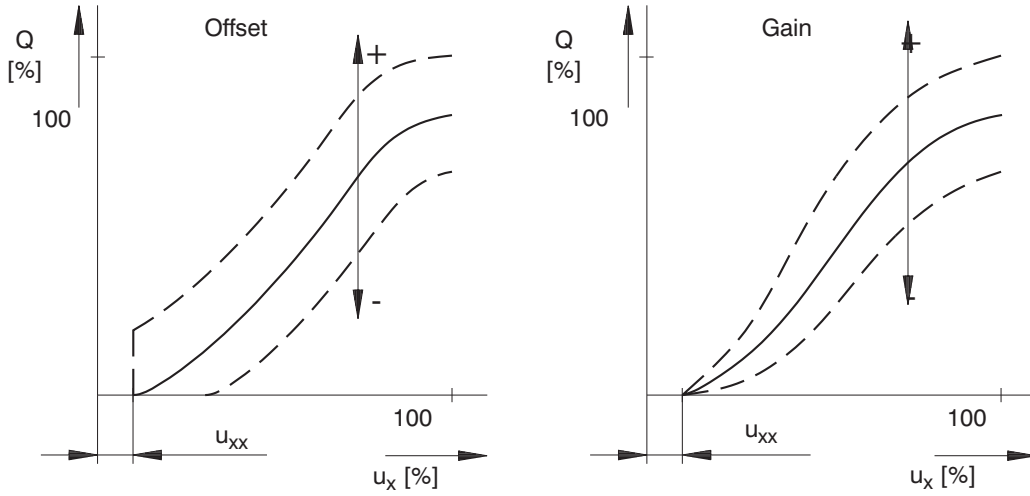

6

Nominal supply voltage of electronics [V]	Area insensible to control signal u_{xx} [%]
12	1 ... 3
24	0.5 ... 2

Valve Dimensions

Dimensions in millimetres

PRM2-062..../-...-

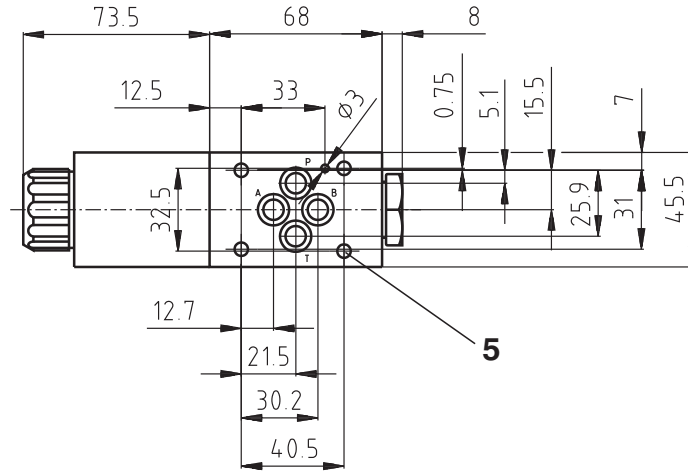

Functional symbols

2Z51, 2Y51

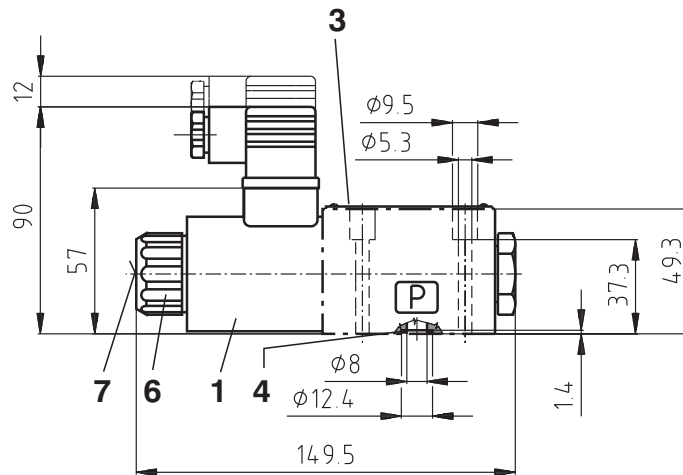

Functional symbols

2Z11, 2Y11

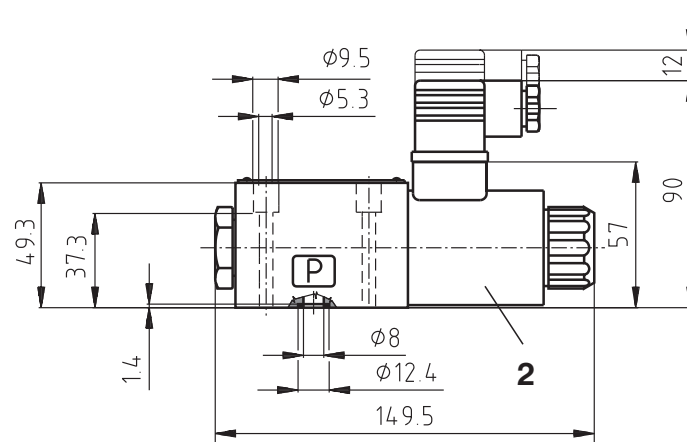

- 1 Solenoid a
- 2 Solenoid b
- 3 Name plate
- 4 Square ring 9.25 x 1.68 (4 pcs.)
supplied in delivery packet
- 5 4 through mounting holes
- 6 Solenoid fixing nut (Nut torque 4 Nm)
- 7 Manual override

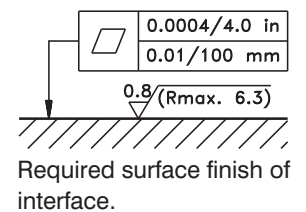

6

Valve Dimensions

Dimensions in millimetres

PRM2-063..../-...-

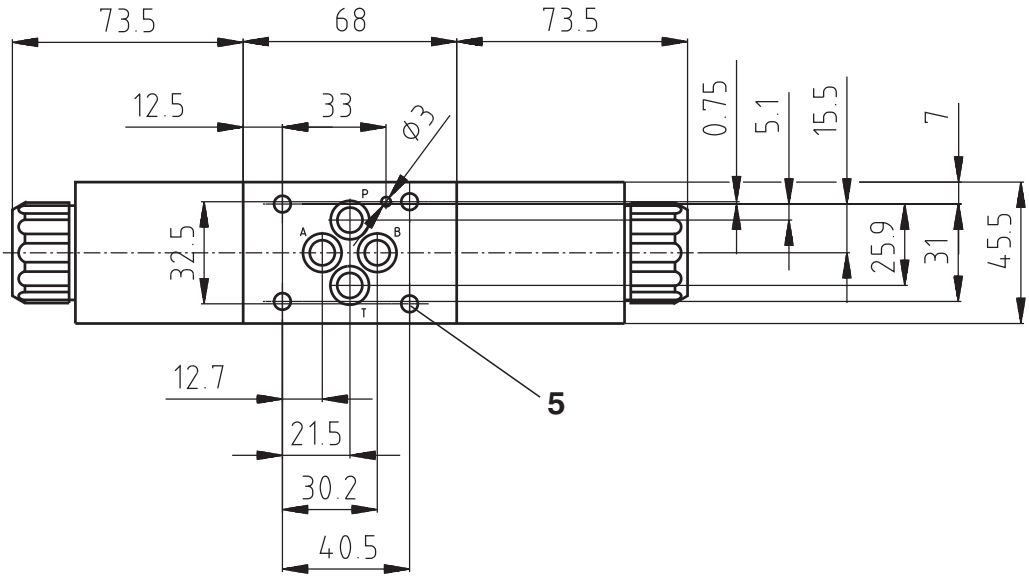

Functional symbols

3Z11, 3Z12, 3Y11, 3Y12

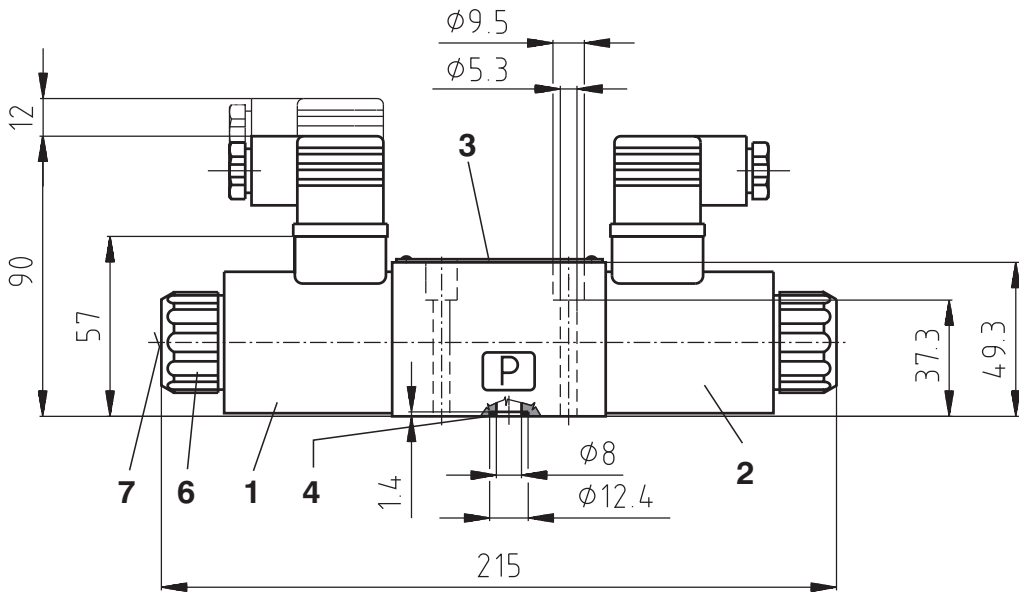

- 1 Solenoid a
- 2 Solenoid b
- 3 Name plate
- 4 Square ring 9.25 x 1.68 (4 pcs.)
supplied in delivery packet
- 5 4 through mounting holes
- 6 Solenoid fixing nut (Nut torque 4 Nm)
- 7 Manual override

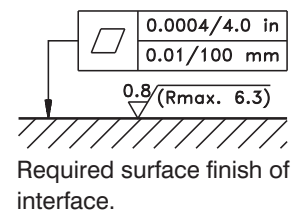

Valve Dimensions

Dimensions in millimetres

PRM2-062..../-...EK.

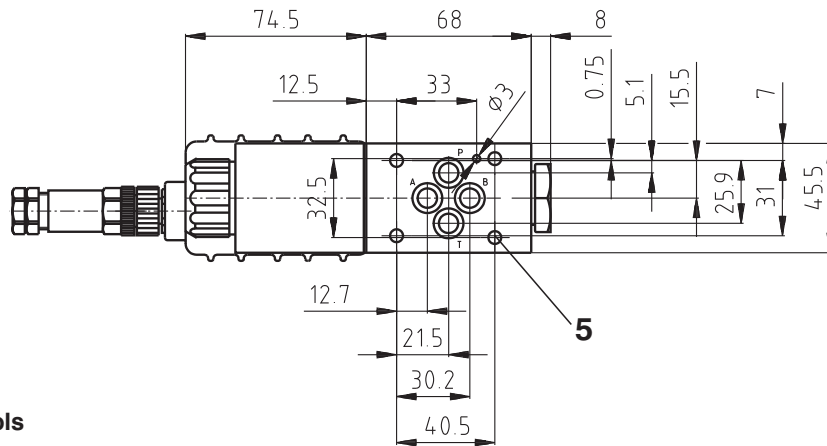

Functional symbols

2Z51, 2Y51

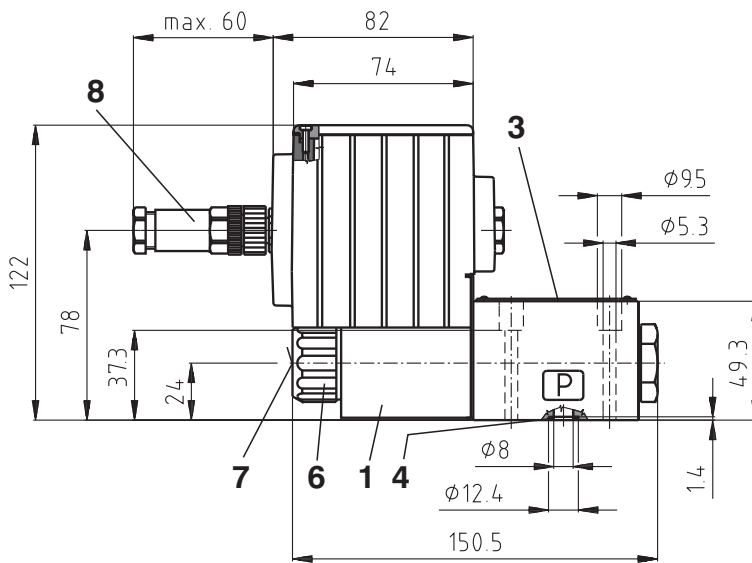

Functional symbols

2Z11, 2Y11

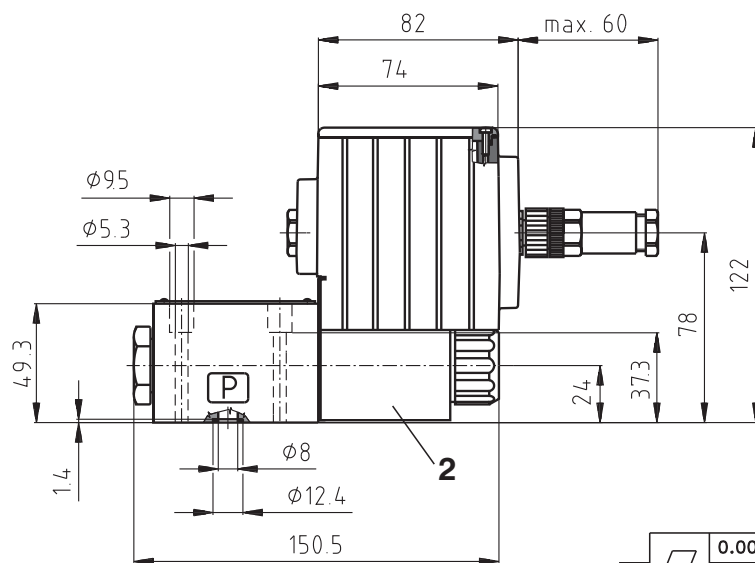

- 1 Solenoid a
- 2 Solenoid b
- 3 Name plate
- 4 Square ring 9.25 x 1.68 (4 pcs.)
supplied in delivery packet
- 5 4 through mounting holes
- 6 Solenoid fixing nut (Nut torque 4 Nm)
- 7 Manual override
- 8 4- pin connector (M12 x 1) for external supply voltage

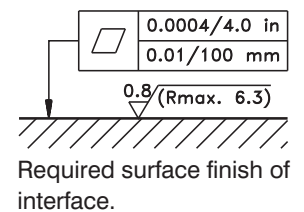

Valve Dimensions

Dimensions in millimetres

PRM2-063..../-...EK.

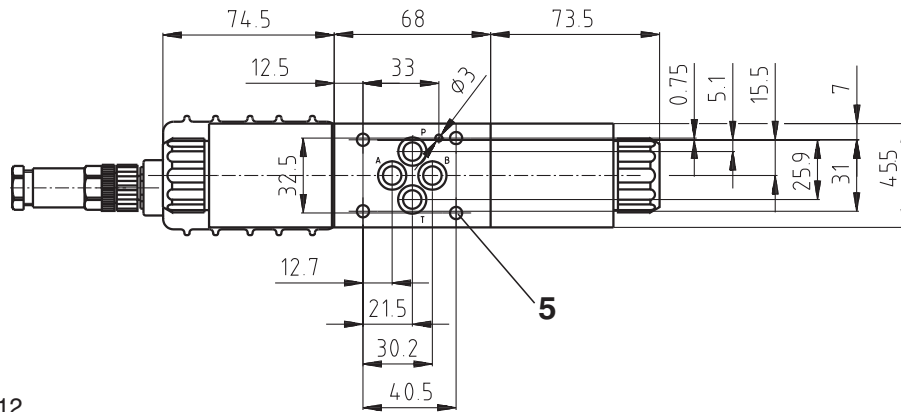

Functional symbols

3Z11, 3Z12, 3Y11, 3Y12

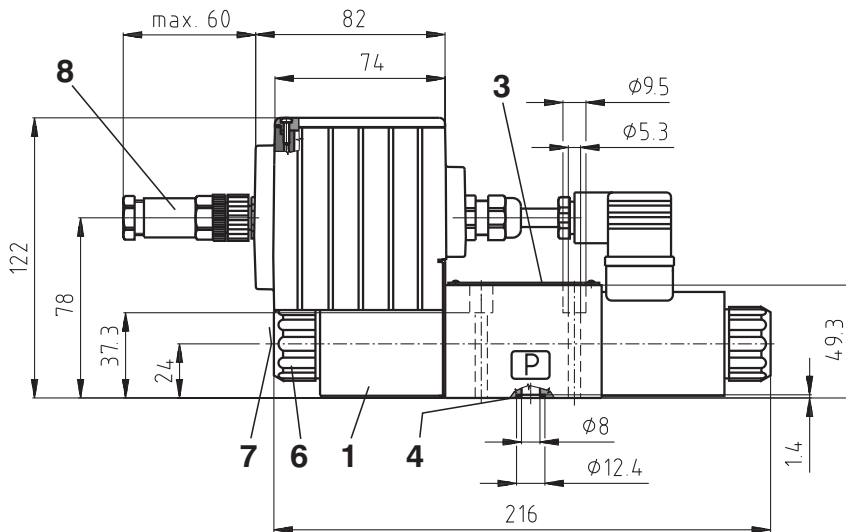

Functional symbols

3Z11B, 3Z12B, 3Y11B, 3Y12B

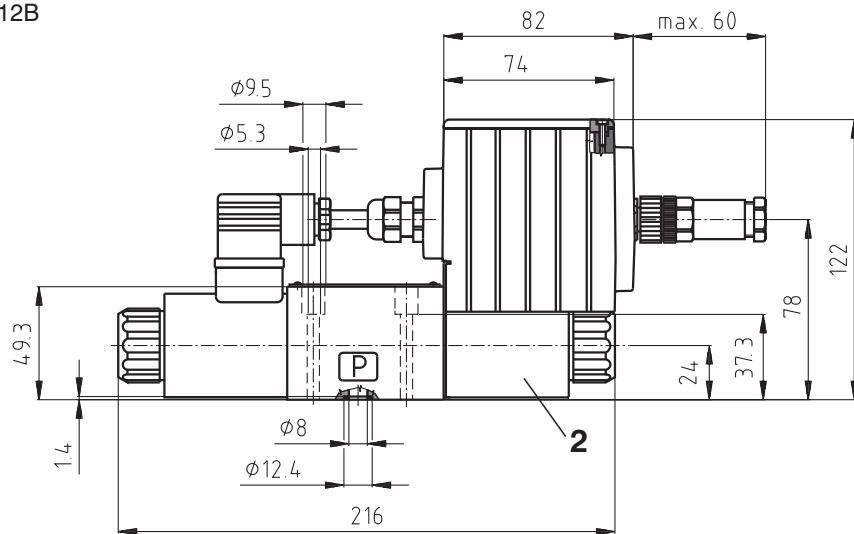

- 1 Solenoid a
- 2 Solenoid b
- 3 Name plate
- 4 Square ring 9.25 x 1.68 (4 pcs.)
supplied in delivery packet
- 5 4 through mounting holes
- 6 Solenoid fixing nut (Nut torque 4 Nm)
- 7 Manual override
- 8 4- pin connector (M12 x 1) for external supply voltage

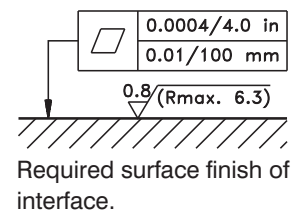

Spare Parts

- 1 Solenoid coil
- 2 Nut + seal ring
- 3 Connector plug EN 175301-803
- 4 Seal kit
- 5 Bolt kit
- 6 Connector

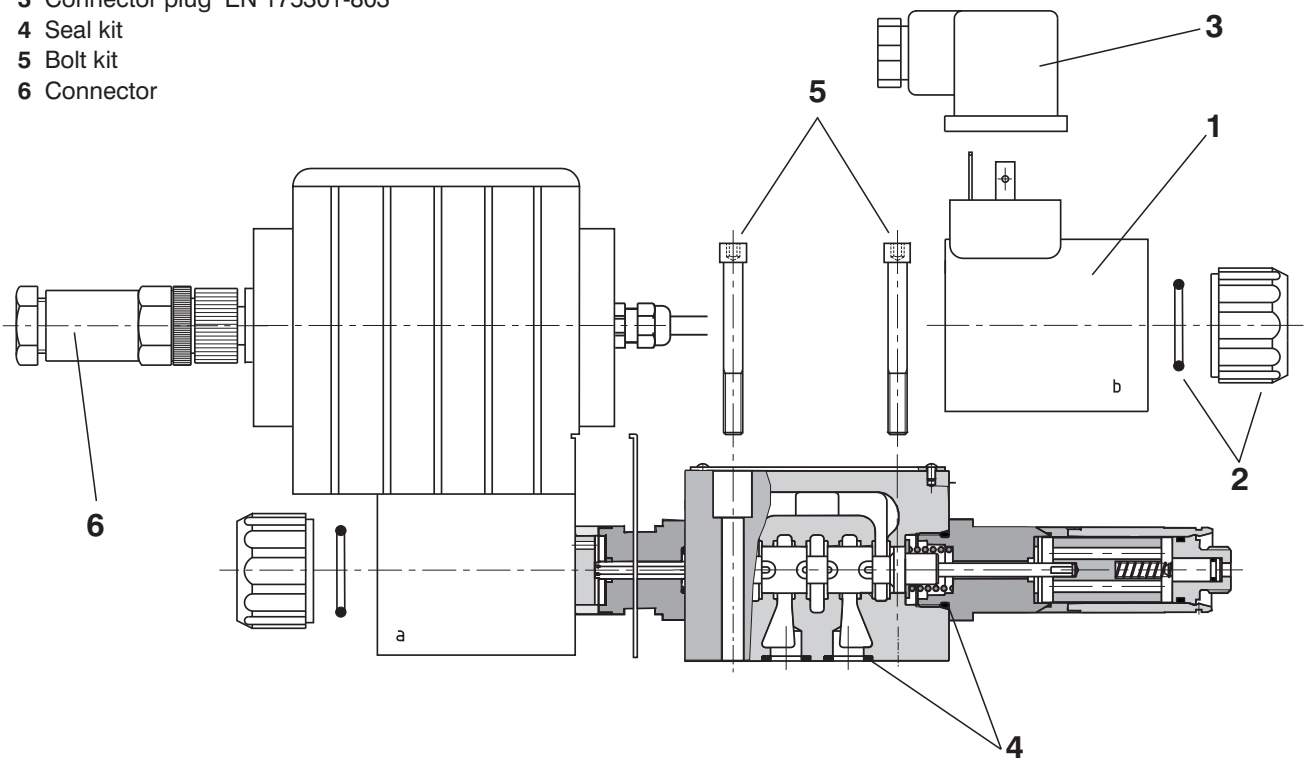

1. Solenoid coil

Nominal supply voltage[V]	Ordering number
12	16186400
12	16187500 (1,6A) (for 12V electronic unit integrated)
24	16186800

2. Solenoid retaining nut with seal ring

Model of the nut	Seal ring	Ordering number
Standard nut	22 x 2	15844600

3. Connector plug to EN 175301-803

Type designation	Type	Maximum input voltage	Connector plug A gray	Connector plug B black
			Ordering number	
K5	without rectifier - M16x1.5 (bushing bore \varnothing 4-6 mm)	230 V DC	16202600	16202500

4. Seal kit

Type	Dimensions, number		Ordering number
Standard - NBR 70	9.25 x 1.68 (4 pcs.)	17 x 1.8 (2 pcs.)	15845200
Viton	9.25 x 1.78 (4 pcs.)	17.17 x 1.78 (2 pcs.)	15845400

5. Bolt kit

Dimensions, number	Tightening torque	Ordering number
M5 x 45 DIN 912-10.9 (4 pcs.)	8.9 Nm	15845100

6. Connector

Ordering number
M12 x 1 (4-pin connector) 358358904012

6

Caution!

- The packing foil is recyclable.
- The protective plate can be returned to manufacturer.
- Mounting bolts M5 x 45 DIN 912-10.9 or studs must be ordered separately.
Tightening torque of the bolts is 6.6 ft-lbs (8.9 Nm).
- The technical information regarding the product presented in this catalogue is for descriptive purposes only. It should not be construed in any case as a guaranteed representation of the product properties in the sense of law.

ARGO-HYTOS s.r.o. CZ - 543 15 Vrchlabí
Tel.: +420-499-403 111
E-mail: info.cz@argo-hytos.com
www.argo-hytos.com

- Compact design with integrated electronics
- High reliability
- Simple replacement of the exciting coils including electronics without opening the hydraulic circuits
- Continuous flow control in both directions
- Installation dimensions to DIN 24 340 / ISO 4401 / CETOP RP121-H

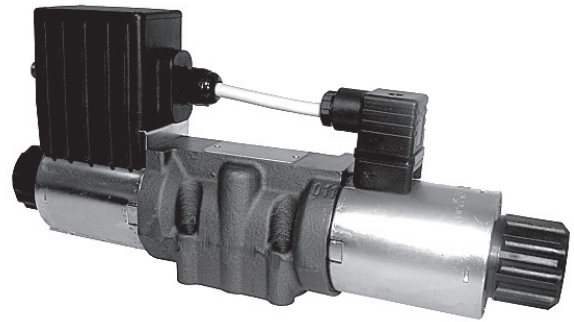
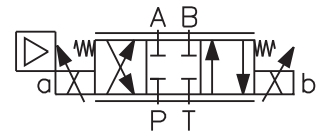

Functional Description

The proportional directional valve consists of a cast-iron housing, a special control spool, two centering springs with supporting washers and one or two proportional solenoids. A control box, which comprises one or two electronic control cards, depending on the number of the controlled solenoids, can be mounted onto either solenoid. With the model with two solenoids, the solenoid mounted apposite the control box is connected with the box by means of a EN connector, a two-cored cable and a bushing. The connection of the control box with the supply source and with the control signal is realized by means of a 4-pin connector, type M12 x 1. The solenoid coils, including the control box, can be turned in the range of $\pm 90^\circ$. The electric control unit supplies the solenoid with current, which varies with the control signal. The solenoid shifts the control spool to the required position, proportional to the control current.

The electronic control unit provides the following adjustment possibilities: Offset, Gain, rise and drop-out time of the ramp generator, frequency (2 frequencies) and amplitude of the dither signal generator. The correct function of the control unit is signaled by LED-diodes. Stabilized voltage +10V (+5V for 12V voltage) is also available for the user. By the use of this voltage, a voltage control signal can be made by means of a potentiometer $\geq 1 \text{ k}\Omega$. The electronic control card enables voltage or current control to be used, according to the positions of the switches SW1 to SW3 (see table on page 6). The basic surface treatment of the valve housing is phosphate coated, the operating solenoids are zinc coated.

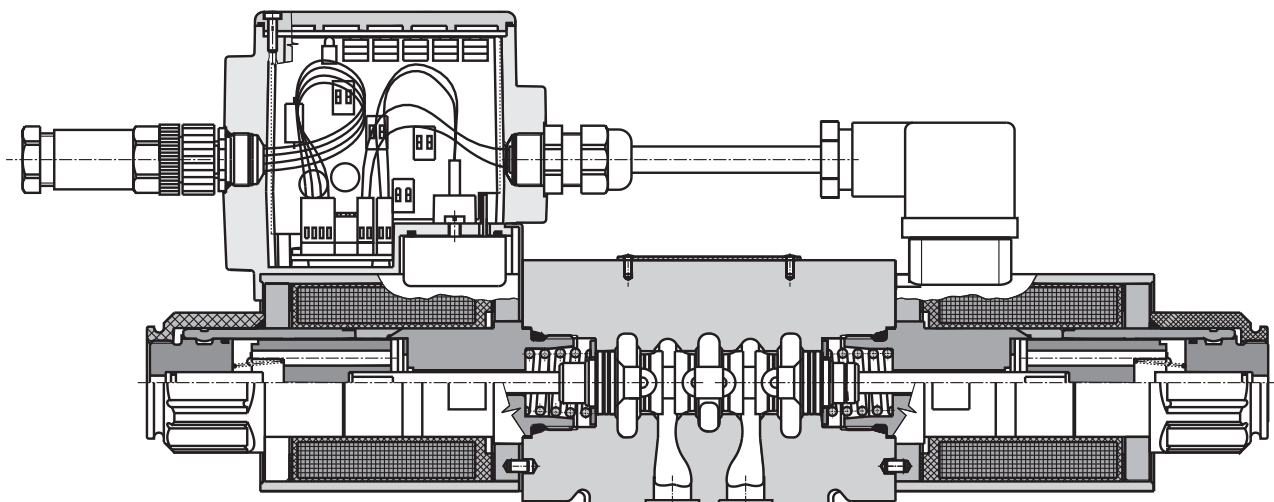

Ordering Code

PRM6-10 / -

Proportional Directional Control Valve

Seals

without designation
V

NBR
FPM (Viton)

Nominal size

10 (D 05)

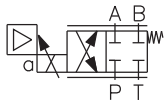

2Z51

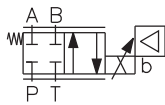

2Z11

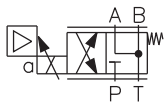

2Y51

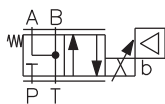

2Y11

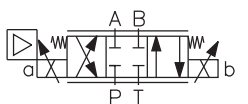

3Z11

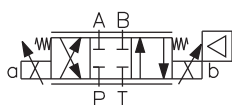

3Z11B

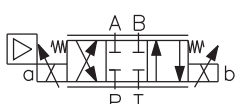

$$\frac{q_A}{q_B} = \frac{1}{2}^*$$

3Z12

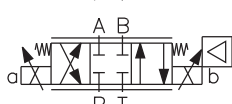

$$\frac{q_A}{q_B} = \frac{1}{2}^*$$

3Z12B

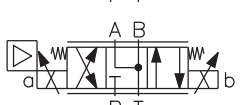

3Y11

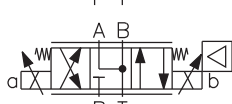

3Y11B

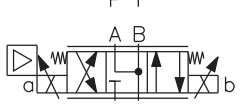

$$\frac{q_A}{q_B} = \frac{1}{2}^*$$

3Y12

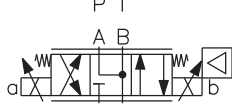

$$\frac{q_A}{q_B} = \frac{1}{2}^*$$

3Y12B

Electronics

without designation without electronics

EK

connection by connector
M12 x 1 (4-pin connector)
(supplied with counterpart)

Nominal supply voltage

12
24

12 V DC
24 V DC

Nominal flow rate at Δp = 10 bar (145 PSI)

30
60

30 L/min (7.93 GPM)
60 L/min (15.85 GPM)

* Model for cylinders with asymmetric piston rod, piston area ratio 1:2

Technical Data

Valve size	mm (US)	10 (D 05)
Maximum operating pressure at ports P, A, B	bar (PSI)	350 (5076)
Maximum operating pressure at port T	bar (PSI)	210 (3046)
Hydraulic fluid	Hydraulic oils of power classes (HL, HLP) to DIN 51524	
Fluid temperature range NBR / Viton	°C (°F)	-30 ... +80 (-22 ... +176) / -20 ... +80 (-4 ... +176)
Ambient temperature, max.	°C (°F)	+50 (+122)
Viscosity range	mm ² /s (SUS)	20 ... 400 (98 ... 1840)
Maximum degree of fluid contamination	Class 21/18/15 to ISO 4406	
Nominal flow rate Q _n at Δp = 145 PSI (10 bar) v = 32 mm ² ·s ⁻¹ (v = 156 SUS)	L/min (GPM)	30 (7.93) / 60 (15.85)
Hysteresis	%	≤ 6
Weight PRM6-102 PRM6-103	kg (lbs)	4.3 (9.48) 5.8 (12.78)
Mounting position	unrestricted, preferably horizontal	
Enclosure type to EN 60529	IP65	

Technical Data of the Proportional Solenoid

Nominal supply voltage	V	12 DC ±10 %	24 DC ±10 %
Limit current	A	1.9	1.1
Mean resistance value at 20 °C (68 °F)	Ω	4.7	13.9

Technical Data of the Electronics

Nominal supply voltage U _{cc}	V	12 DC	24 DC
Supply voltage range	V	11.2 ... 14.7 DC	20 ... 30 DC
Stabilized voltage for control	V	5 DC (R > 1 kΩ)	10 DC (R ≥ 1 kΩ)
Control signal	see table of switches configuration (page 6)		
Maximum output current	A	2.4 for R < 4Ω	1.5 for R < 10Ω
Ramp adjustment range	s	0.05 ... 3	
Dither frequency	Hz	90 / 60	
Dither amplitude	%	0 ... 30	

Limit Power

Measured at v = 32 mm²/s (166 SUS)

Nominal flow 30 L/min (7.93 GPM)

Nominal flow 60 L/min (15.85 GPM)

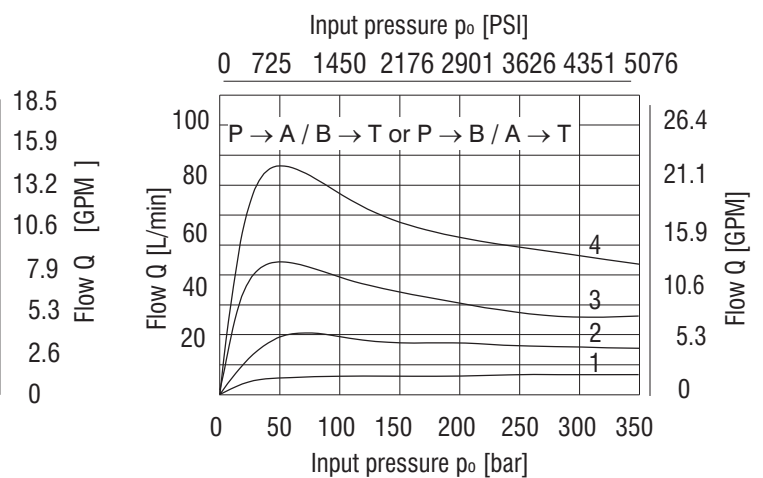
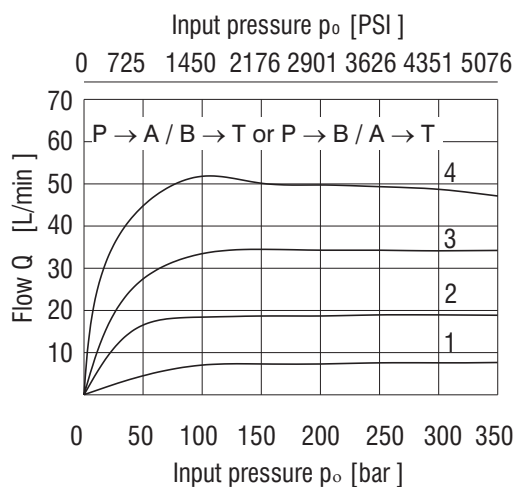

Solenoid current: (24 V DC)

- 1 = 40%
- 2 = 60%
- 3 = 80%
- 4 = 100%

Flow Characteristic with Integrated Electronics

Measured at $\Delta p = 10 \text{ bar (145 PSI)}$, $v = 32 \text{ mm}^2/\text{s (156 SUS)}$

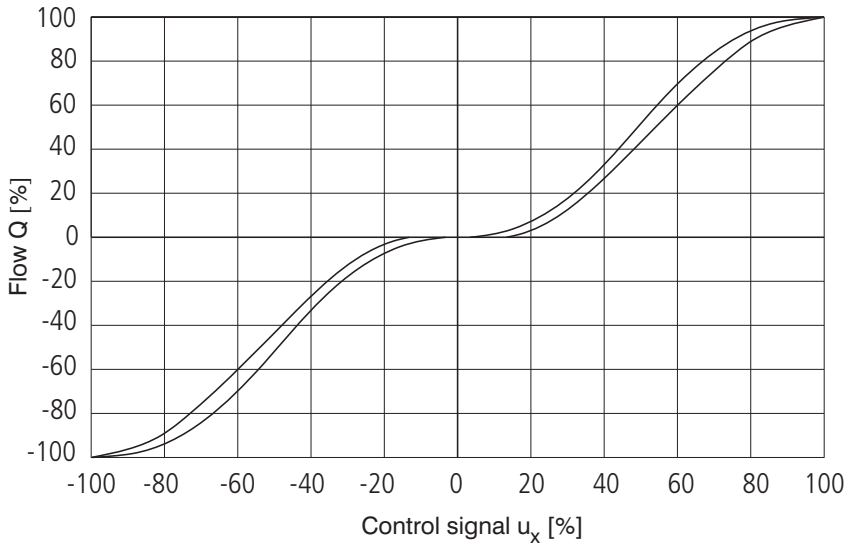

Flow Characteristic without Integrated Electronics

Measured at $\Delta p = 10 \text{ bar (145 PSI)}$, $v = 32 \text{ mm}^2/\text{s (156 SUS)}$,

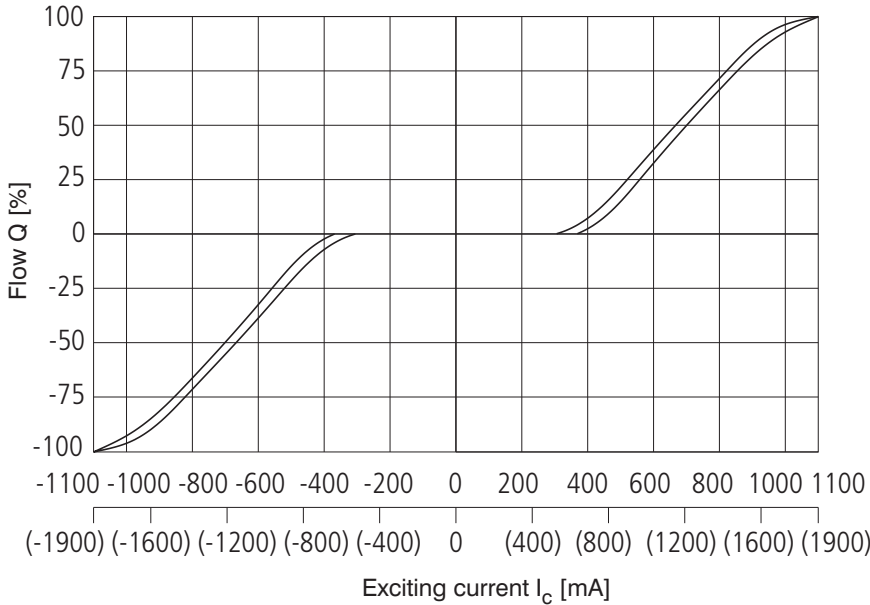

Values in parenthesis are valid for the supply voltage 12 V.

The coil current which initializes the flow through the proportional directional valve can differ due to the production tolerances about in a range of $\pm 6\%$ of the limit current.

Transient Characteristic

Measured at $\Delta p = 10 \text{ bar (145 PSI)}$, $v = 32 \text{ mm}^2/\text{s (156 SUS)}$; $Q = 80\% Q_n$

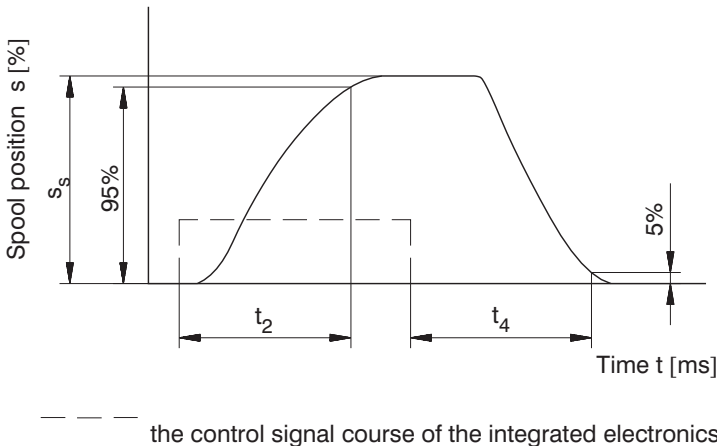

Steady spool position s_s [%]	t_2 [ms]	t_4 [ms]
100	160	145
75	135	130
50	85	105
25	50	70

The values in table have only an informative character.

The times of the transient characteristics at pressure or flow control will be in a particular hydraulic circuit always longer.

Frequency Reponse

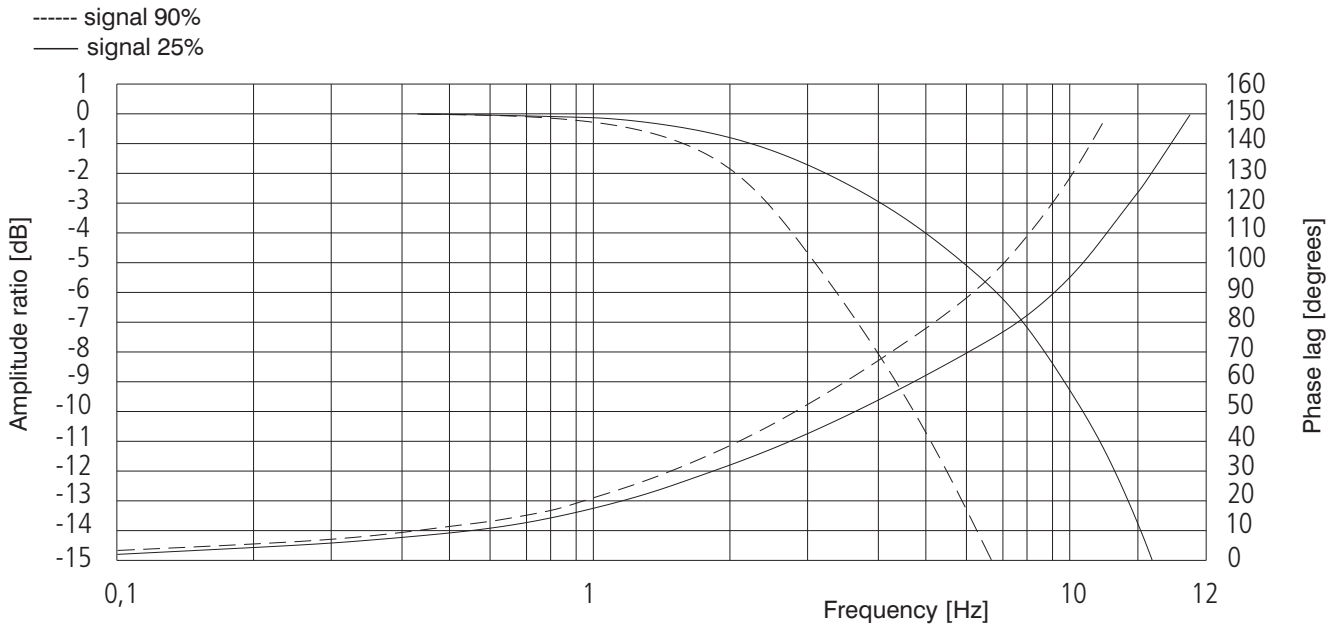

Component Arrangement on the Electronic Card

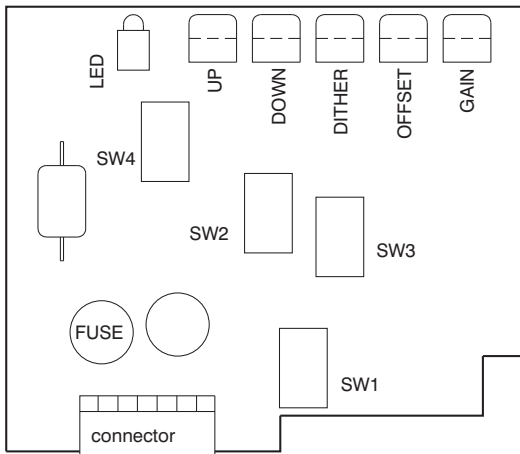

- SW1 - control signal choice
- SW2 - control signal choice
- SW3 - control signal choice
- SW4 - dither frequency

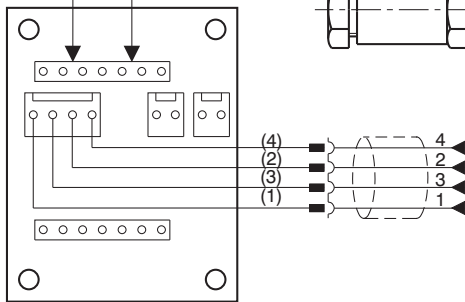

Description basic subplatte

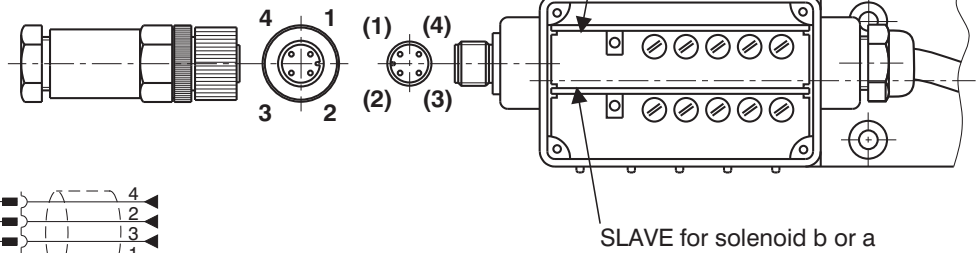
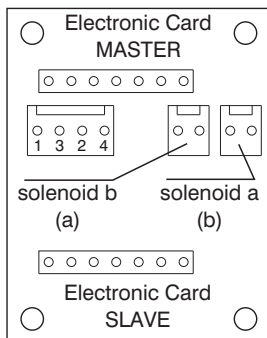

PIN	Description
1	+24 V (U_{CC}) (+12 V)
2	control
3	0 V
4	+10 V (+5 V)

Table of the Switch Configuration for the Control Signal Choices

		PRM6-102				PRM6-103	
		0 ... 5 V	0 ... 10 V (0 ... 5 V)*	0 ... 20 mA	4 ... 20 mA	$U_{cc}/2$ $\pm 10 V (\pm 5 V)^*$	$\pm 10 V$ $(\pm 5 V)^*$
MASTER M	SW1						
	SW2						
	SW3						
	SW4	90 Hz			60 Hz		
SLAVE S	SW1	X					
	SW2						
	SW3						
	SW4					90 Hz	

Designation of the basic manufacture setting.



The ramp functions are adjusted on their minimum values, the dither is set to the optimal value with respect to hysteresis. Offset and Gain are adjusted according to the characteristic on page 3 and 4. The manufacturer does not recommend these adjusted values to be changed.

* Input signal level for the 12 V electronic unit.

Block Diagram

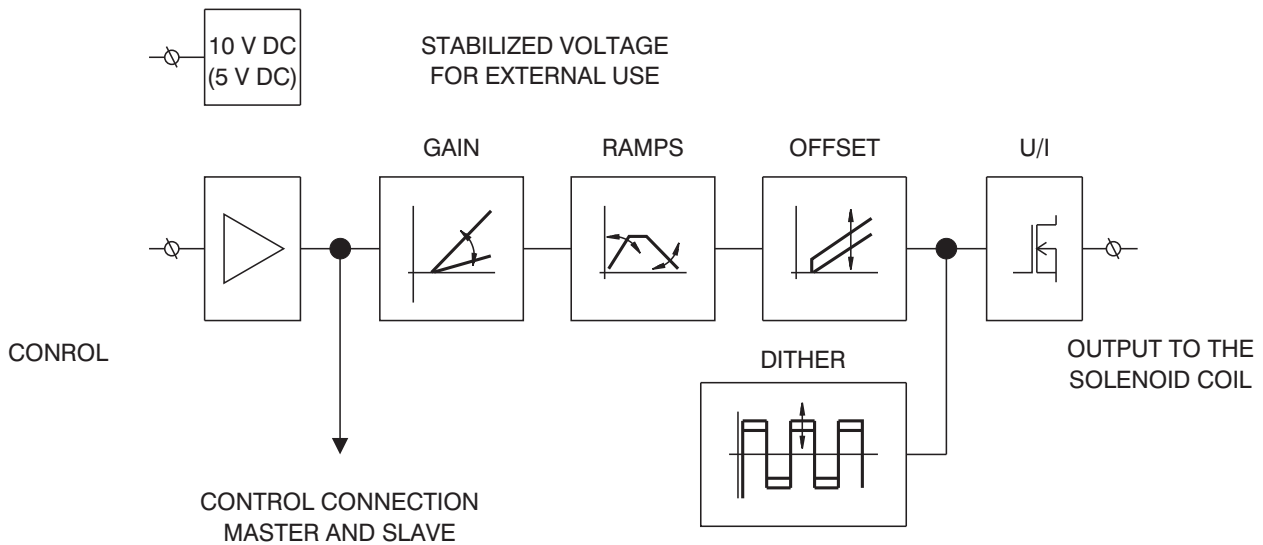

Valve PRM6-102 (with One Solenoid)

1 Factory setting

1.1 Control with external voltage source 0 ... 10 V (0 ... 5 V) or with external potentiometer R > 1 kΩ

Notice:

The control signal must have the same ground potential as the supply source.

Master card for solenoid a (b)

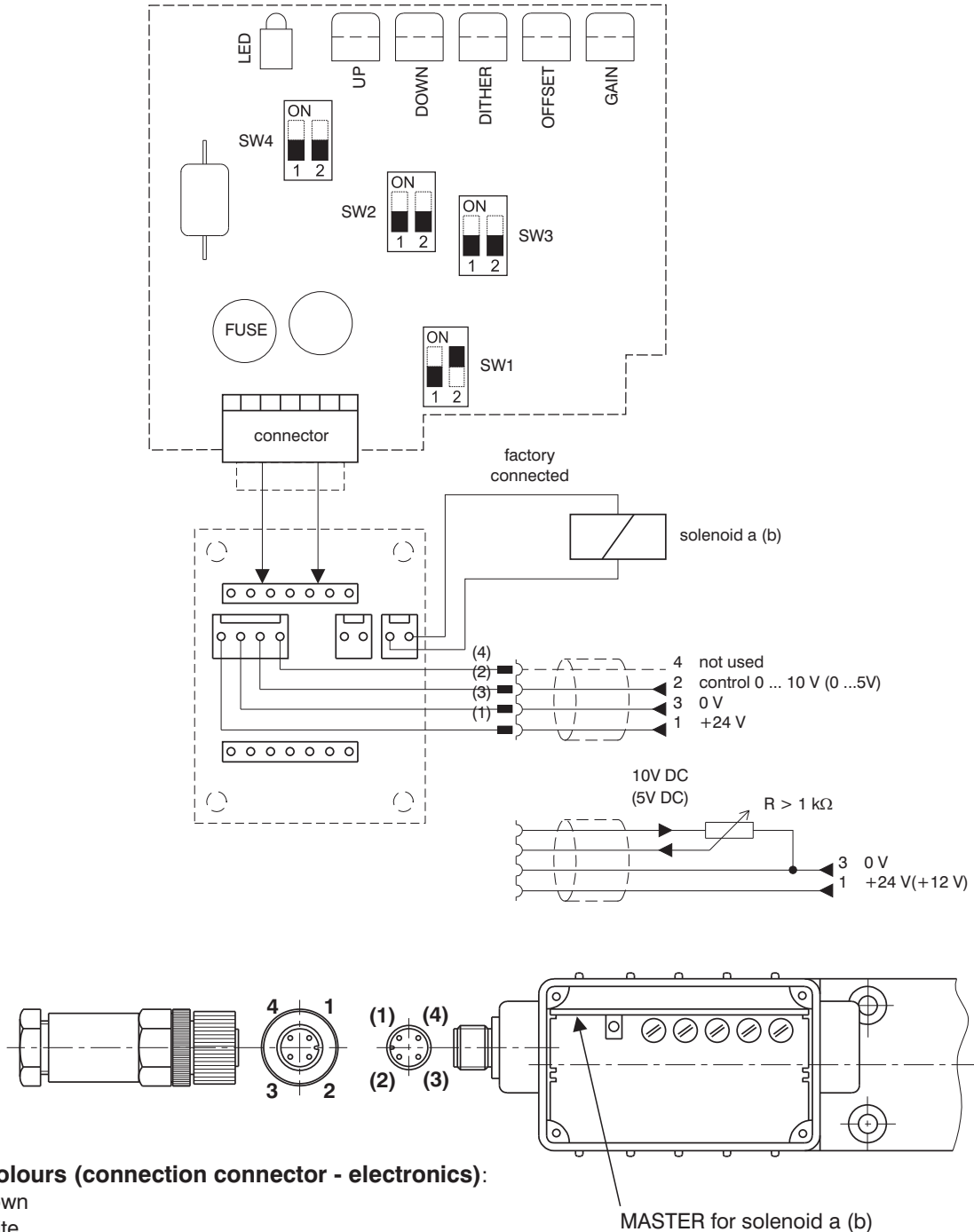

Wire colours (connection connector - electronics):

- (1) - brown
- (2) - white
- (3) - blue
- (4) - black

Factory set values:

Control signal: 0 - 10 V (0 - 5V)

Dither: frequency 90Hz
amplitude - optimum

Ramps: 0.05 s

Offset, Gain: according to the characteristics on page 3, 4

Valve PRM6-102 (with One Solenoid)

2 Other control possibilities

2.1 Control with external source 0 ... 5 V

Notice:

The control signal must have the same ground potential as the supply source.

Master card for solenoid a (b)

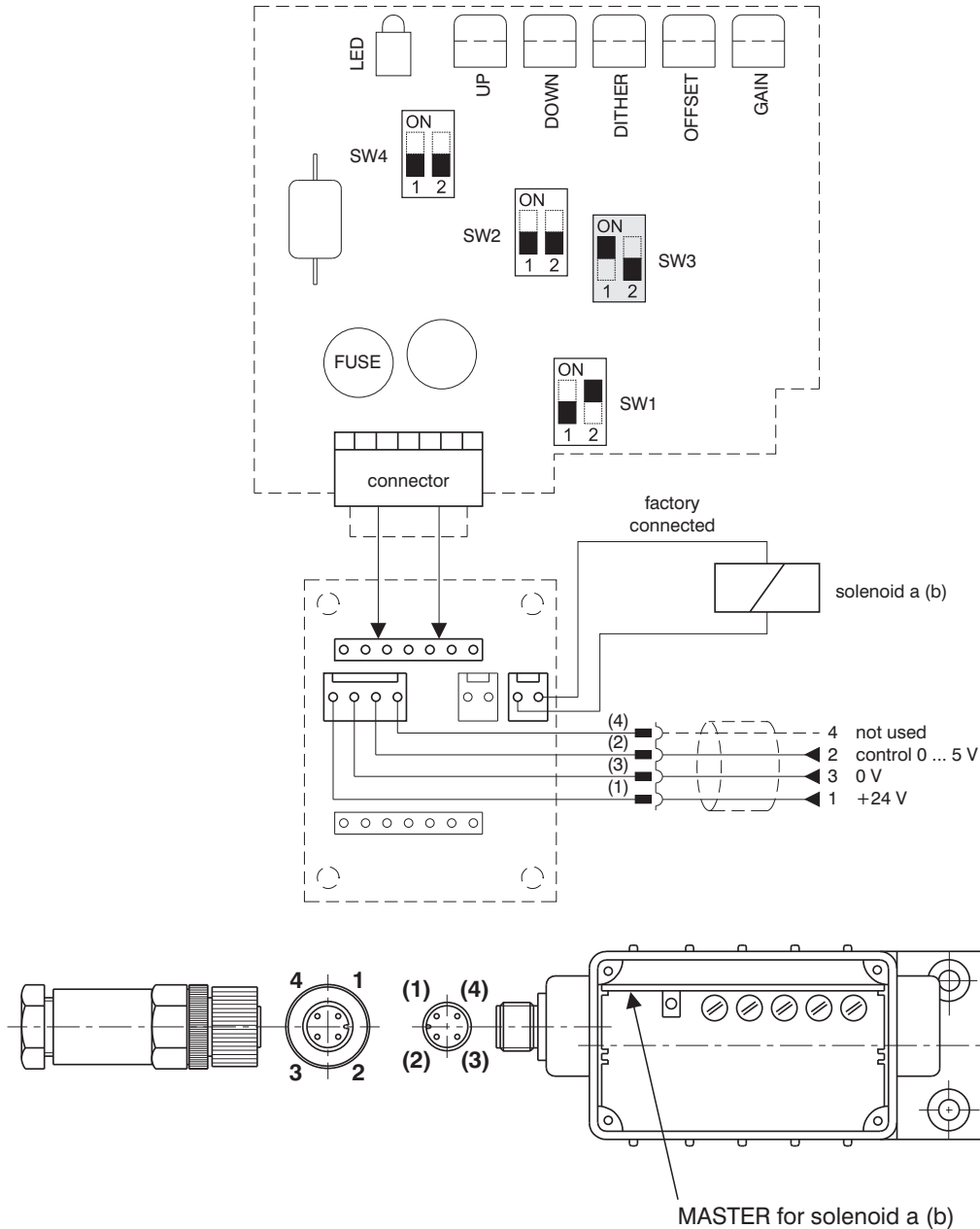

For the factory setting modification for this case of application, the following steps are required:

1. Unscrew the electronics cover
2. Carefully remove the Master card
3. Flip the switch SW3 in position shown in the picture
4. Put in the Master card and fix the electronics cover
5. Connect the voltage +24 V from an external supply source to terminals 1 and 3 of the connector
6. Connect the control voltage 0 ... 5 V from an external source to terminals 2 and 3 of the connector

Valve PRM6-102 (with One Solenoid)

2.2 Control with external source 0 ... 20 mA

Notice:

The control signal must have the same ground potential as the supply source.

Master card for solenoid a (b)

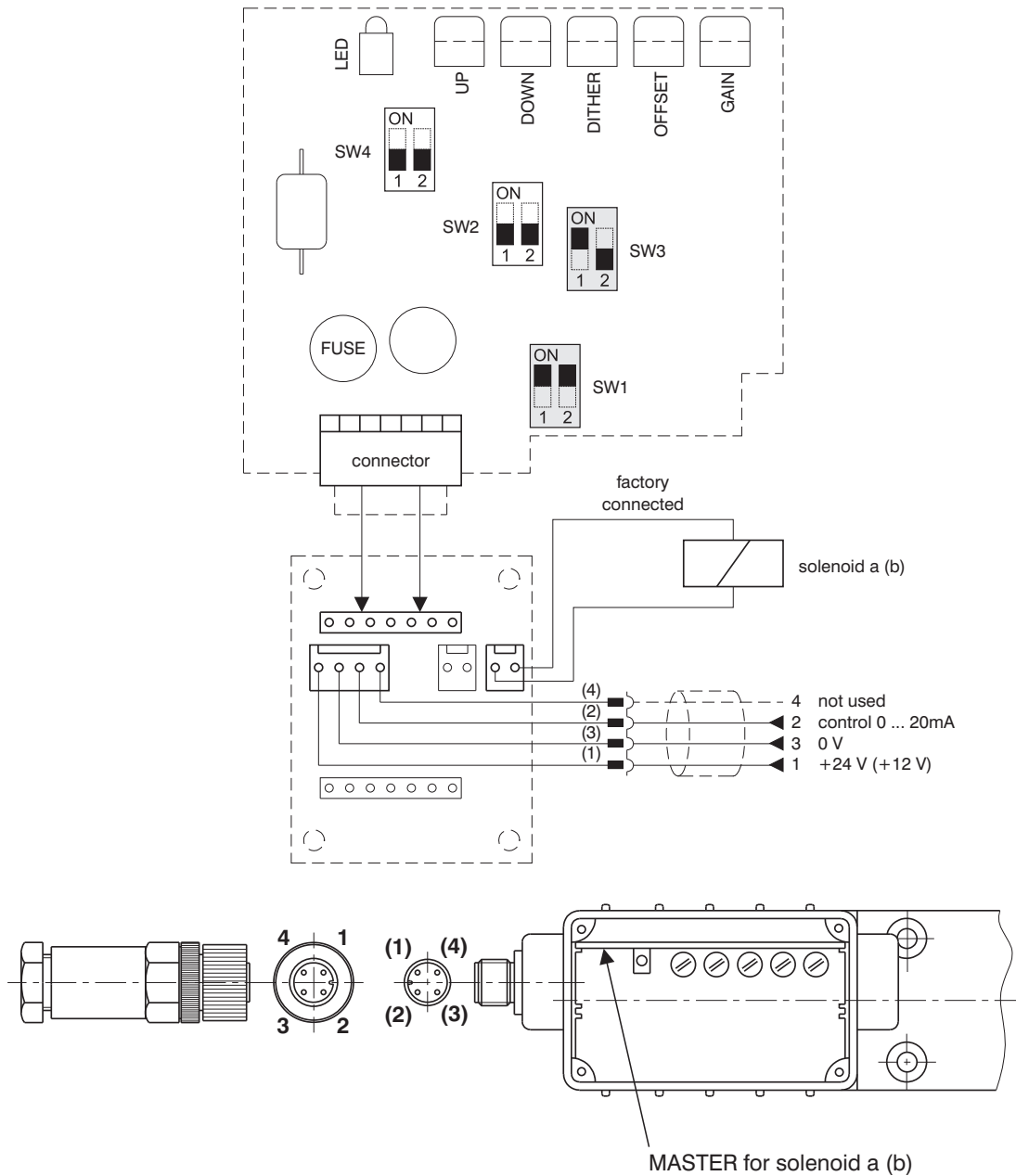

For the factory setting modification for this case of application, the following steps are required:

1. Unscrew the electronics cover
2. Carefully remove the Master card
3. Flip the switch SW1 and SW3 in position shown in the picture
4. Put in the Master card and fix the electronics cover
5. Connect the voltage +24 V (+12 V) from an external supply source to terminals 1 and 3 of the connector
6. Bring the control current 0 ... 20 mA from an external source to terminals 2 and 3 of the connector

Valve PRM6-102 (with One Solenoid)

2.3 Control with external source 4 ... 20 mA

Notice:

The control signal must have the same ground potential as the supply source.

Master card for solenoid a (b)

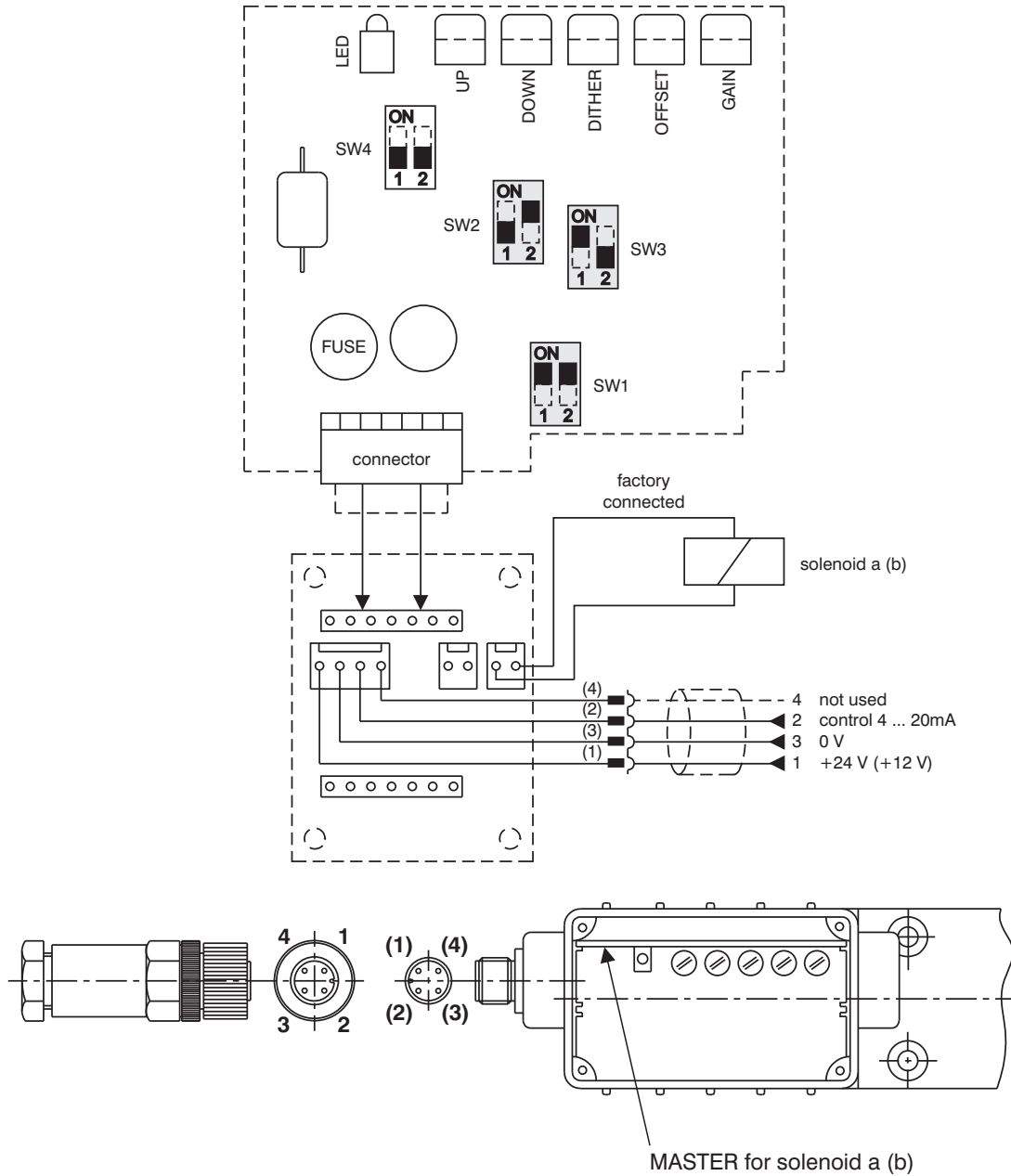

For the factory setting modification for this case of application, the following steps are required:

1. Unscrew the electronics cover
2. Carefully remove the Master card
3. Flip the switch SW1, SW2 and SW3 in position shown in the picture
4. Put in the Master card and fix the electronics cover
5. Connect the voltage +24 V (+12 V) from an external supply source to terminals 1 and 3 of the connector
6. Bring the control current 4 ... 20 mA from an external source to terminals 2 and 3 of the connector

Valve PRM6-103 (with Two Solenoids)

3 Factory setting

3.1 Control with external source $0 \pm 10 \text{ V}$ ($0 \pm 5 \text{ V}$)

Notice:

The control signal must have the same ground potential as the supply source.

Master card for solenoid a (b)

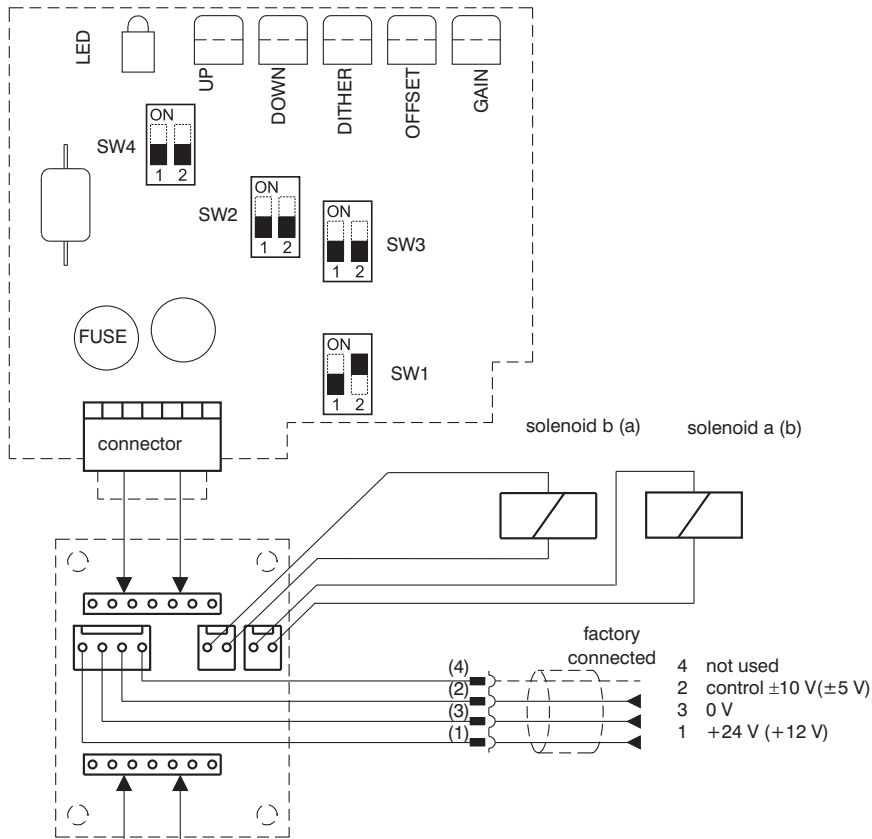

Slave card for solenoid b (a)

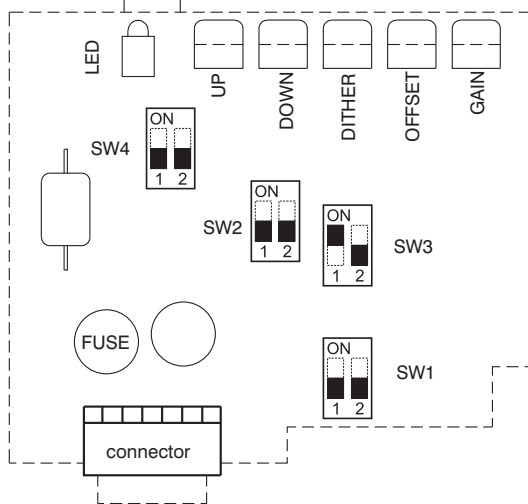

Factory set values:

Control signal: $0 \pm 10 \text{ V}$ ($0 \pm 5 \text{ V}$)

Dither: frequency 90 Hz
amplitude - optimum

Ramps: 0.05 s

Offset, Gain: according to the characteristics on page 3, 4

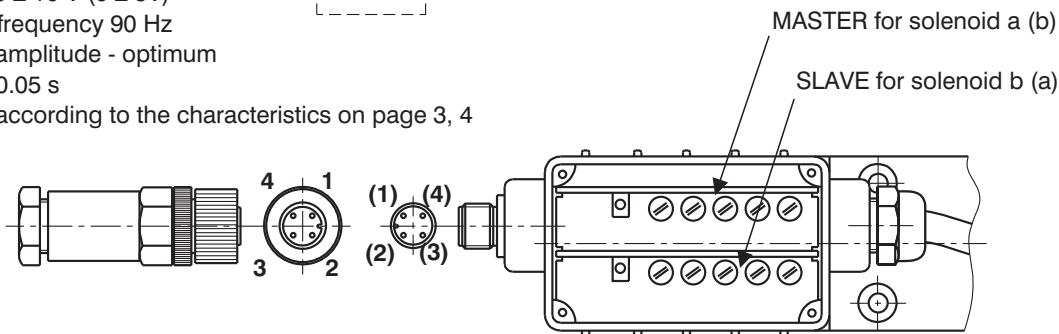

6

Valve PRM6-103 (with Two Solenoids)

3.2 Other control possibilities

Control $U_{cc}/2 \pm 10 V (U_{cc}/2 \pm 5V)$ external potentiometer $R > 1 k\Omega$

Master card for solenoid a (b)

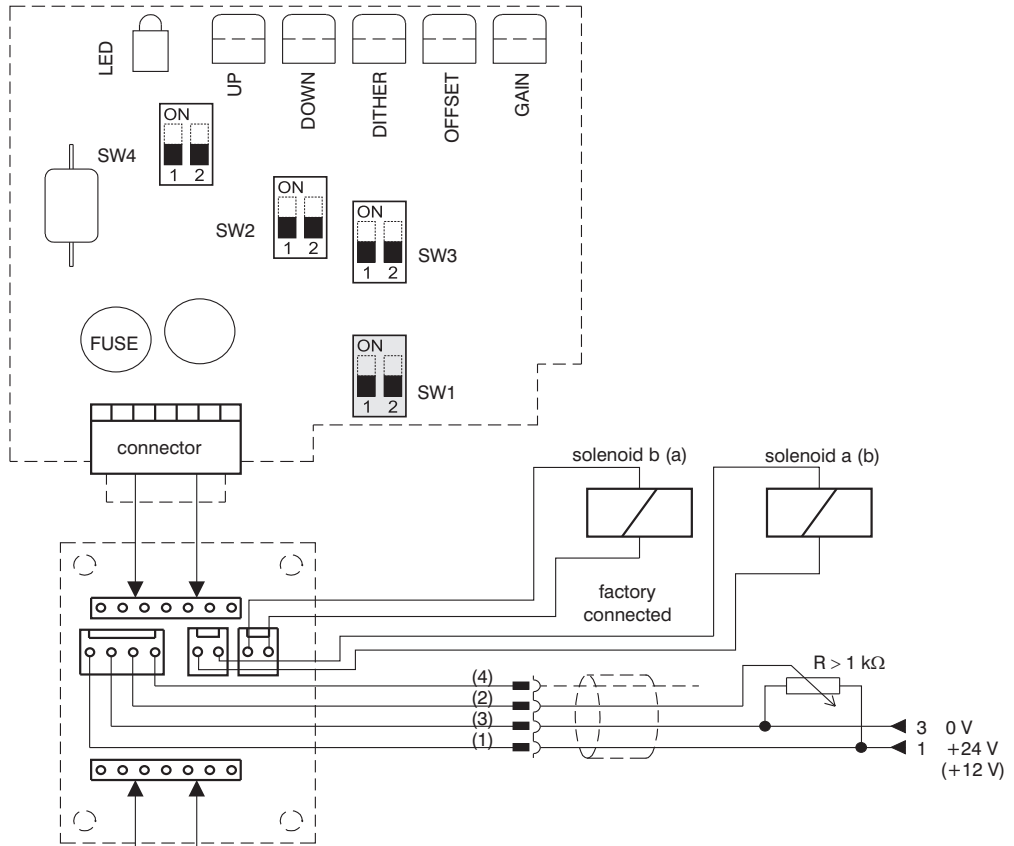

Slave card for solenoid b (a)

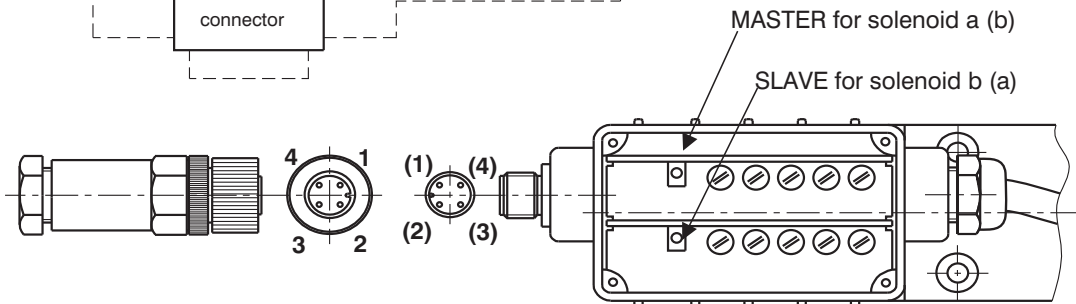
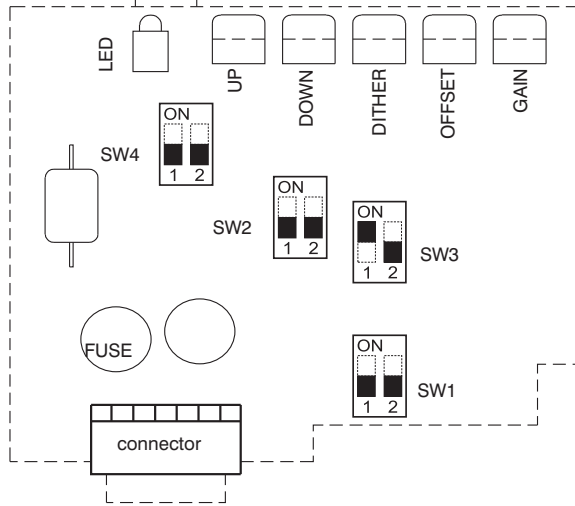

For the factory setting modification for this case of application, the following steps are required:

1. Unscrew the electronics cover
2. Carefully remove the Master card
3. Flip the switch SW1 in position shown in the picture
4. Put in the Master card and fix the electronics cover
5. Connect the voltage +24 V (+12 V) from an external supply source to terminals 1 and 3 of the connector

Ramp Adjustment (Up, Down)

Notice: The factory setting of the ramp functions is to the minimum values.

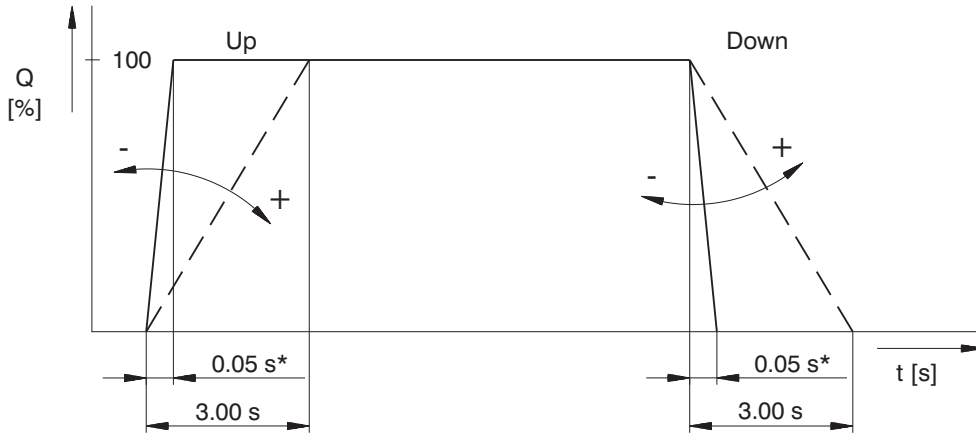

*The value has only an informative character with respect to the particular type of the proportional directional valve (see page 4)

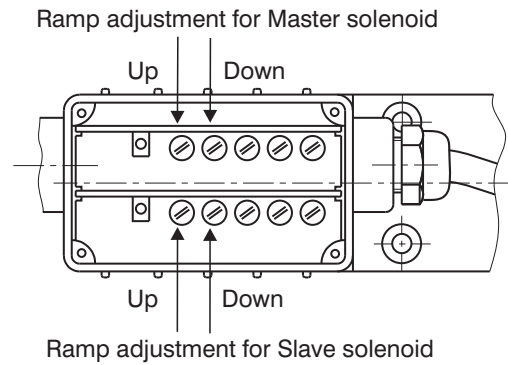
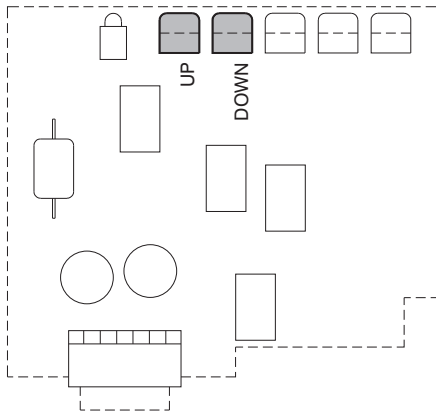
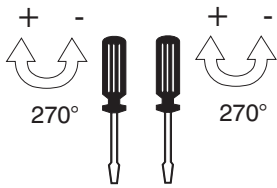

Dither Adjustment

Notice: The dither is adjusted with regard to the minimum hysteresis.

Amplitude - potentiometer (dither) (0 - 30 %)

Frequency - switch SW4

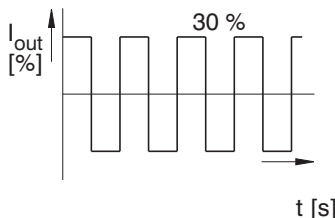
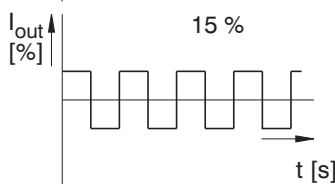
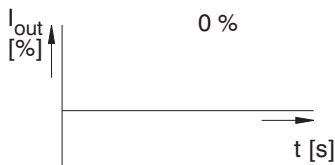

Amplitude adjustment for Master solenoid

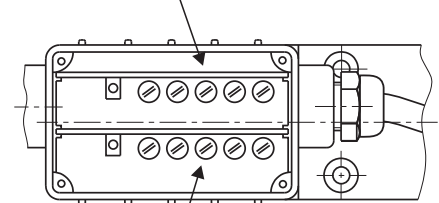

Amplitude adjustment for Slave solenoid

Adjustment of Offset, Gain Parameters

Notice: The factory setting of the Offset and Gain parameters is specific for the solenoids used. The manufacturer does not recommend this setting to be changed.

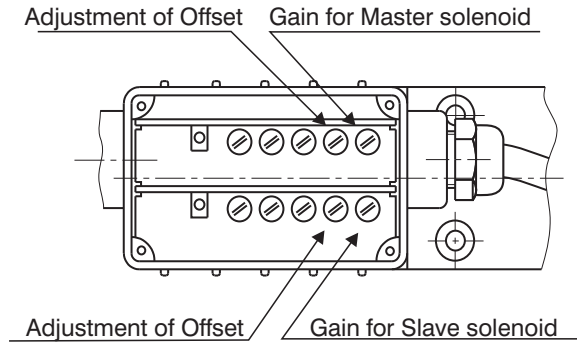
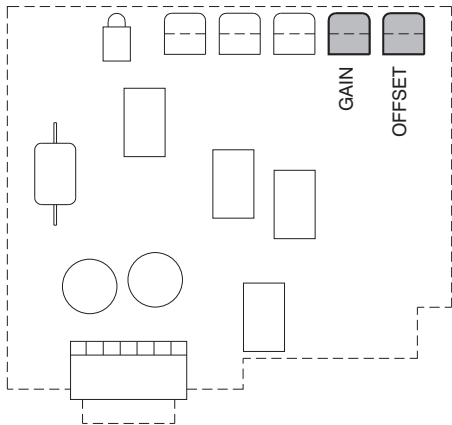
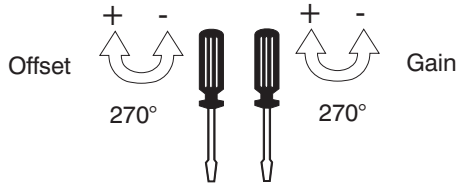
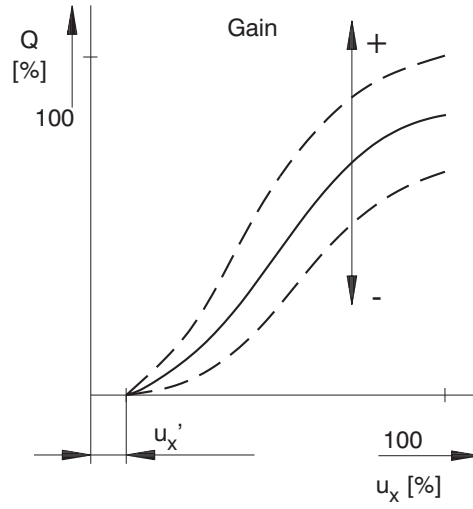
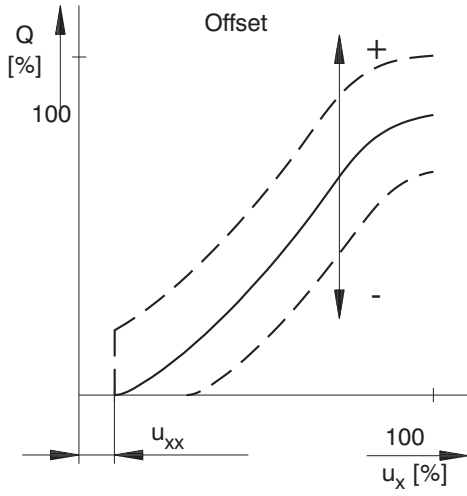

Nominal supply voltage of electronics [V]	Area insensible to control signal u_{xx} [%]
12	1 ... 3
24	0.5 ... 2

Valve Dimensions

Dimensions in millimetres (in inches)

PRM2-102..../-...-

Functional symbols
2Z51, 2Y51

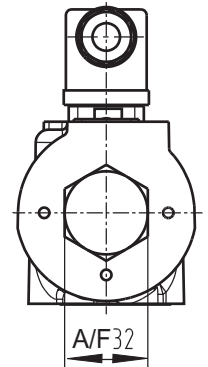
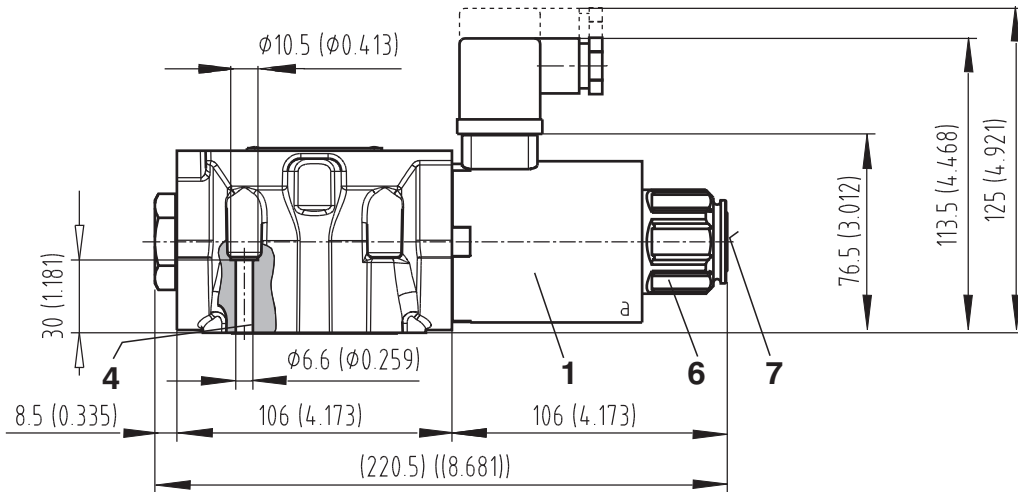
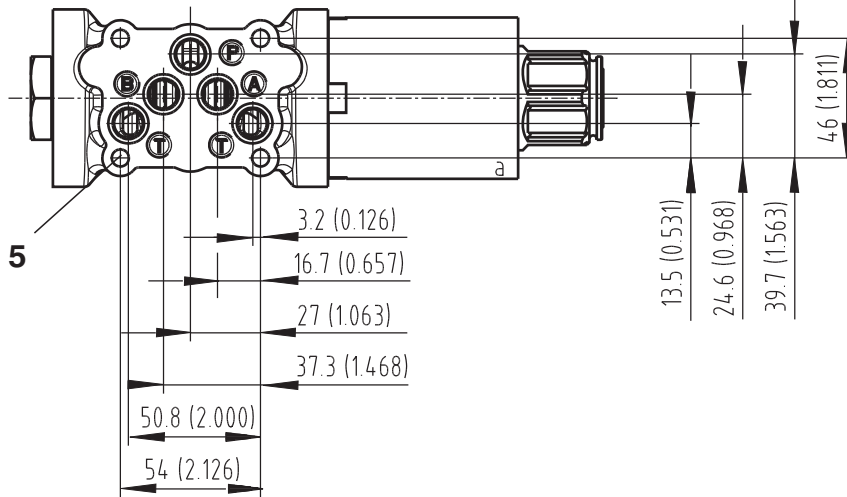

Functional symbols
2Z11, 2Y11

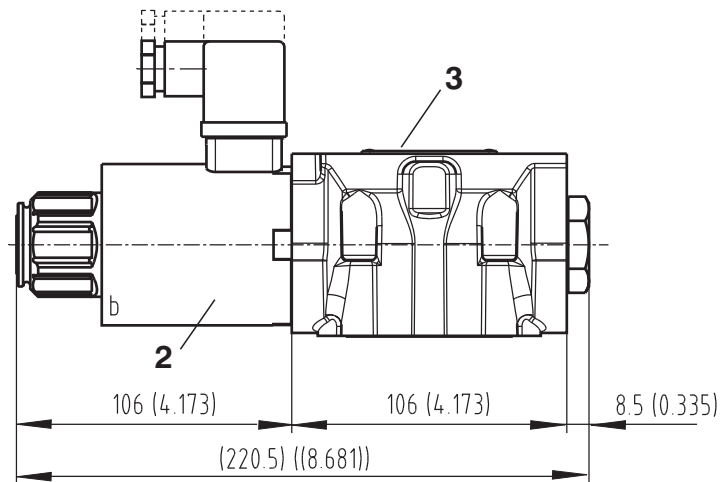

- 1 Solenoid a
- 2 Solenoid b
- 3 Name plate
- 4 Square ring 12.42 x 1.68 (5 pcs.)
supplied in delivery packet
- 5 4 through mounting holes
- 6 Solenoid fixing nut [Nut torque 6 Nm (4.43 lbf.ft.)]
- 7 Manual override

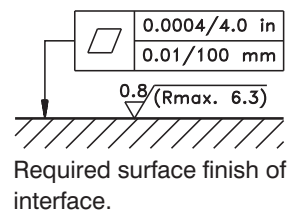

6

Valve Dimensions

Dimensions in millimetres (in inches)

PRM6-103..../-...-

Functional symbols
3Z11, 3Z12, 3Y11, 3Y12

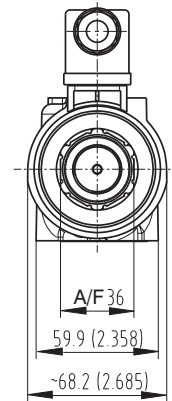
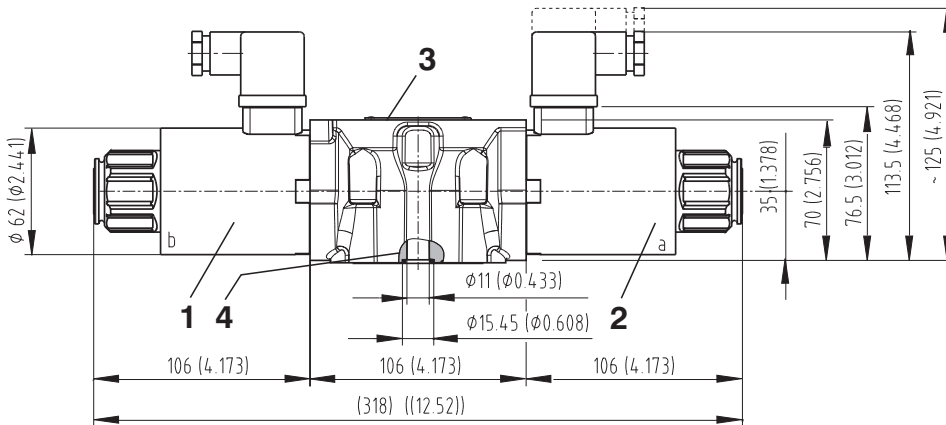
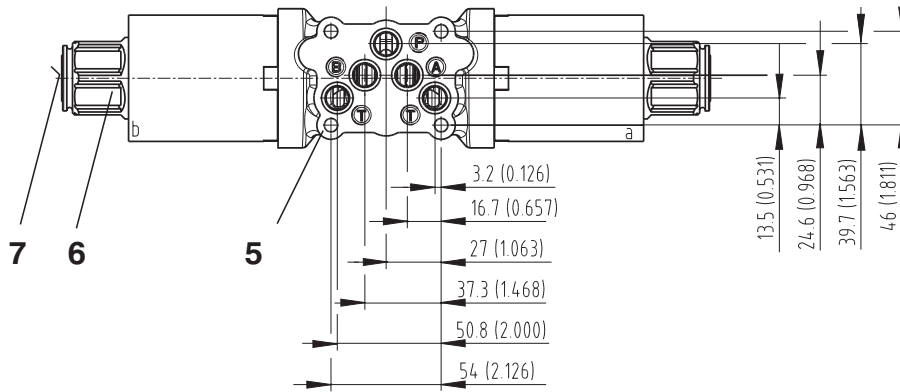

- 1 Solenoid a
- 2 Solenoid b
- 3 Name plate
- 4 Square ring 12.42 x 1.68 (5 pcs.)
supplied in delivery packet
- 5 4 through mounting holes
- 6 Solenoid fixing nut [Nut torque 6 Nm (4.43 lbf.ft.)]
- 7 Manual override

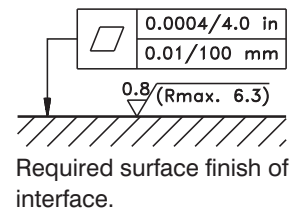

Valve Dimensions

Dimensions in millimetres (in inches)

PRM6-102..../...EK..

Functional symbols
2Z51, 2Y51

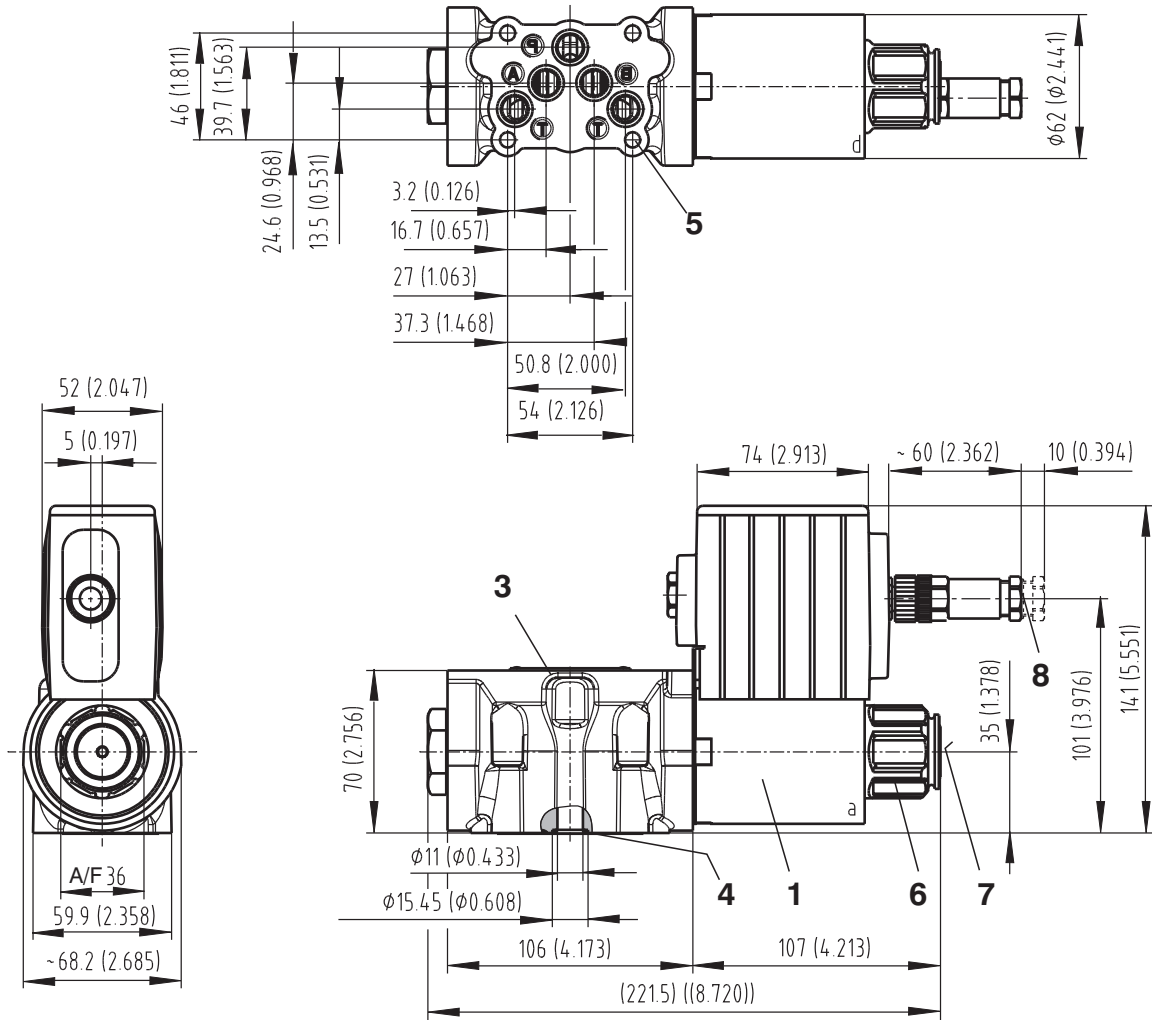

PRM6-102...B/...EK..

Functional symbols
2Z11, 2Y11

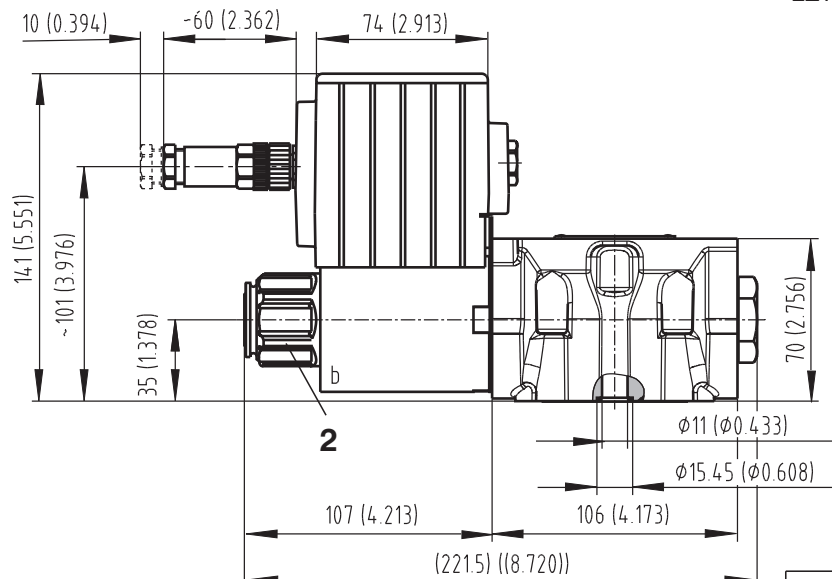

- 1 Solenoid a
- 2 Solenoid b
- 3 Name plate
- 4 Square ring 12.42 x 1.68 (5 pcs.)
supplied in delivery packet
- 5 4 through mounting holes
- 6 Solenoid fixing nut [Nut torque 6 Nm (4.43 lbf.ft.)]
- 7 Manual override
- 8 4- pin connector M12 x 1 for external supply voltage

0.0004/4.0 in
0.01/100 mm

0.8/(Rmax. 6.3)

Required surface finish of interface.

6

Valve Dimensions

Dimensions in millimetres (in inches)

PRM6-103..../-...EK..

Functional symbols
3Z11, 3Z12, 3Y11, 3Y12

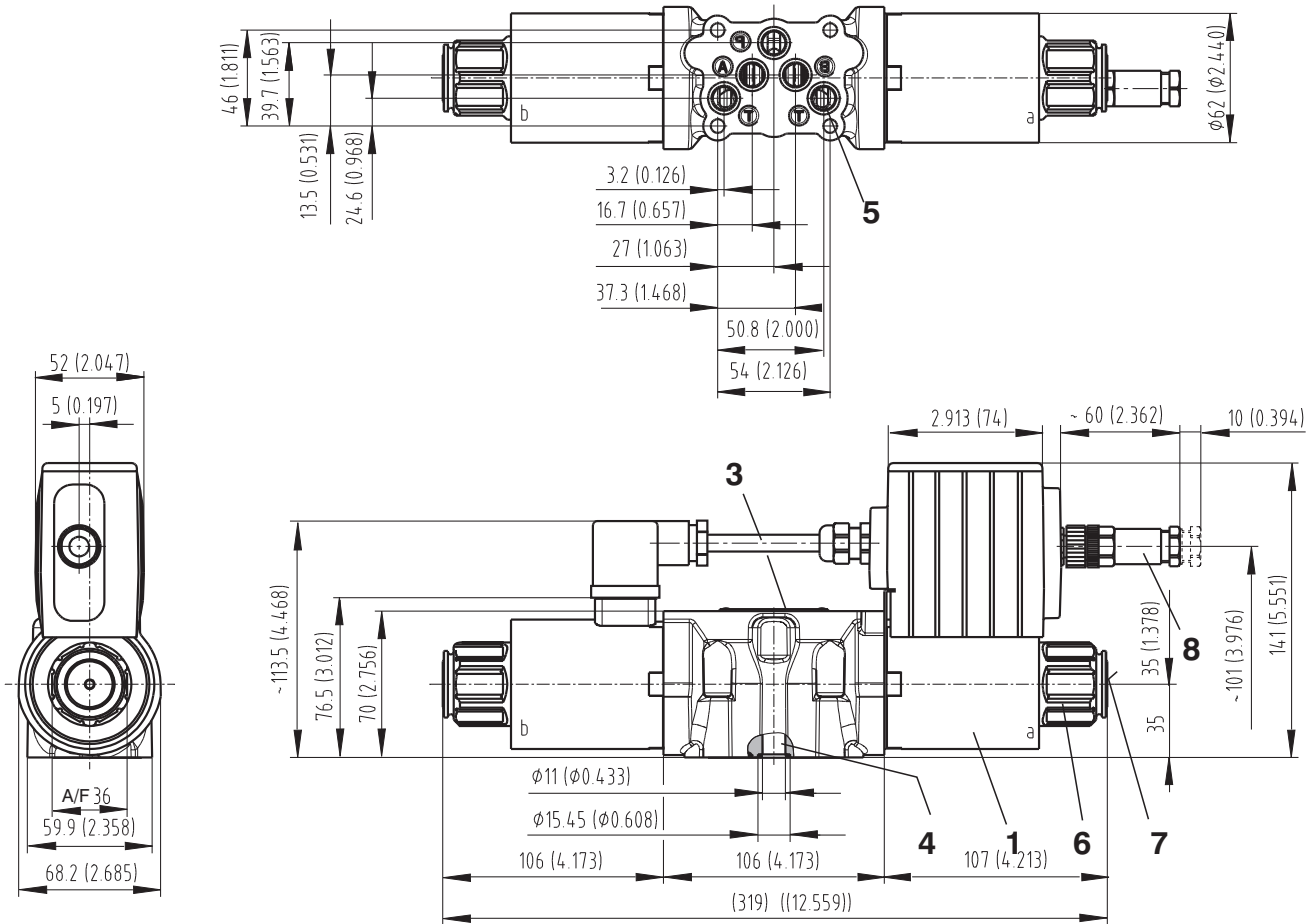

PRM6-103...B/...EK..

Functional symbols
3Z11B, 3Z12B, 3Y11B, 3Y12B

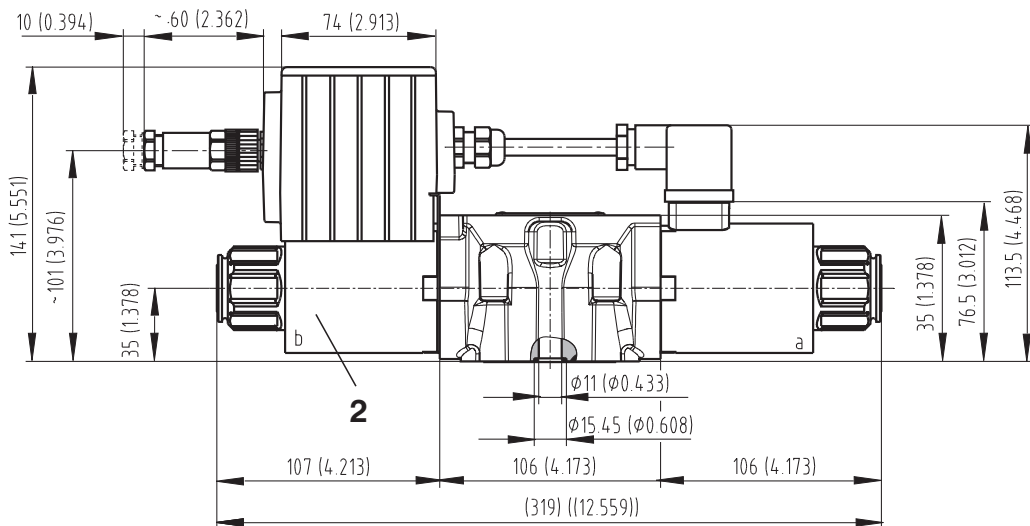

- 1 Solenoid a
- 2 Solenoid b
- 3 Name plate
- 4 Square ring 12.42 x 1.68 (5 pcs.)
supplied in delivery packet
- 5 4 through mounting holes
- 6 Solenoid fixing nut [Nut torque 6 Nm (4.43 lbf.ft.)]
- 7 Manual override
- 8 4- pin connector M12 x 1 for external supply voltage

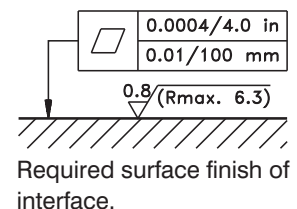

Spare Parts

- 1 Solenoid coil
- 2 Nut + seal ring
- 3 Connector plug EN 175301-803
- 4 Seal kit
- 5 Bolt kit
- 6 Connector

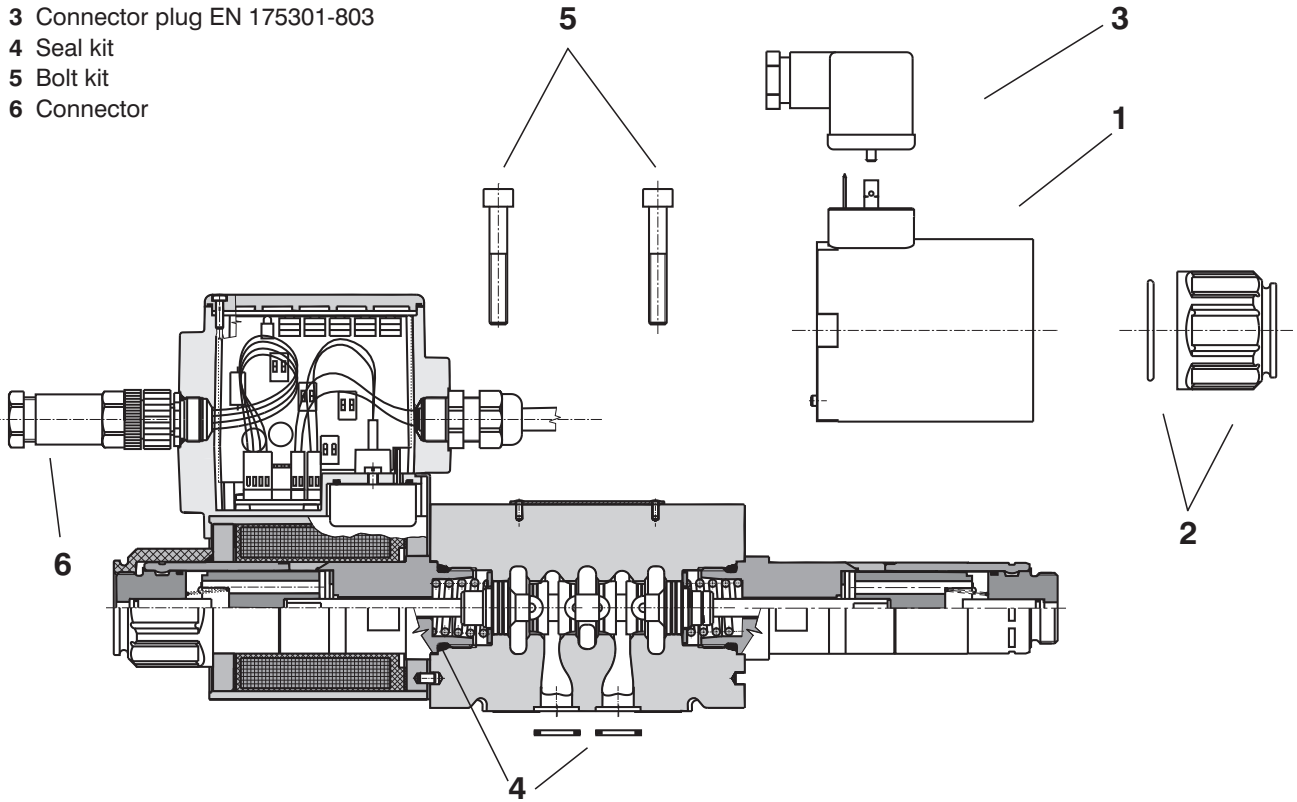

1. Solenoid coil

Nominal supply voltage [V]	Ordering number
12	16195800
24	16196200

2. Solenoid retaining nut + seal ring

Model of the nut	Seal ring	Ordering number
Standard nut	30 x 2	15900800

3. Connector plug to EN 175301-803

Type designation	Type	Maximum input voltage	Connector plug A gray	Connector plug B black
			Ordering number	
K5	without rectifier - M16x1.5 bushing bore \varnothing 4-6 mm (\varnothing 0.16-0.24 in)	230 V DC	16202600	16202500

4. Seal kit

Type	Dimensions, number		Ordering number
Standard - NBR 70	12,42 x 1,68 (5 pcs.)	23,81 x 2,62 (2 pcs.)	23114300
Viton	12,42 x 1,68 (5 pcs.)	23,47 x 2,62 (2 pcs.)	23114400

5. Bolt kit

Dimensions, number	Tightening torque	Ordering number
M6 x 40 DIN 912-10.9 (4 pcs.)	14 Nm (10.33 lbf.ft)	15847700

6. Connector

Ordering number
M12 x 1 (4-pin connector) 358358904012

6

Caution!

- The packing foil is recyclable. The protective plate can be returned to manufacturer.
- Mounting bolts M6 x 40 DIN 912-10.9 or studs must be ordered separately.
Tightening torque of the bolts is 14 Nm (10.33 lbf.ft).
- The technical information regarding the product presented in this catalogue is for descriptive purposes only. It should not be construed in any case as a guaranteed representation of the product properties in the sense of law.

ARGO-HYTOS s.r.o. CZ - 543 15 Vrchlabí
Tel.: +420-499-403 111
E-mail: info.cz@argo-hytos.com
www.argo-hytos.com

- Digital control
- Compact design
- Operated by proportional solenoids
- High sensitivity and slight hysteresis
- Installation dimensions to DIN 24 340 / ISO 4401 / CETOP RP121-H

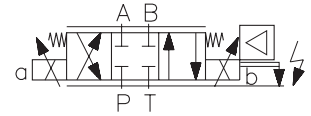
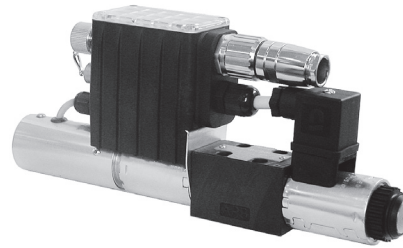

Functional Description

The proportional directional valve PRM7 consists of a cast iron housing, a special control spool, two centering springs with supporting washers, one or two proportional solenoids, a position sensor or, if need be, of a control box with digital electronics.

The measuring system of the position sensor consists of a differential transformer with core and from the evaluating electronic unit realized in hybrid technique.

With the model without integrated electronic unit, the electric connection of the solenoids is realized by the connector plug to EN 175301-803, with the position sensor output being connected by the G4W1F connector plug. Both connectors are supplied.

The proportional valve with the integrated electronic unit comprises an electronic control box that is mounted, together with the position sensor, on either of the solenoids. The connection of the position sensor with the control box is provided by a cable. With the model with two solenoids, the solenoid mounted opposite the control box is connected with the control box by means of a EN 175301-803, connector. The connection of the supply voltage, control signal, program input and external output of the position sensor is realized by a 5-pin connector (ELKA 5012). The connection of the external feedback is provided by a 5-pin connector, which also has three supply voltages +24 V, +10V and -5V for an external sensor available. The solenoid coils, including the control box, can be turned in a range of $\pm 90^\circ$. The digital control unit enables the proportional valve to be controlled on the basis of data required from two feedback circuits.

In this case the proportional valve can be used as follows:

1. Proportional directional valve
2. Only with the internal feedback from the spool position sensor.
3. Only with the external feedback (pressure sensor, position sensor, etc.).
4. With internal and external feedback.

The outlet current to the electromagnet coils is controlled with the help of PWM. The electronic system is equipped with an internal current feedback. The outlet current in case of need may be modulated with the use of a signal of dynamic lubrication. Single function parameters are set up with the use of appropriate software with the help of a computer connected to the proportional switchboard through a serial interface RS 232.

It is necessary to order a cable in accordance with appropriate ordering number as mentioned on page 4.

The digital control unit utilizes the pulse-with-modulation (PWM) and supplies the solenoids with current proportional to the control signal. The supply current is additionally modulated with a dither frequency. The individual functional parameters are adjusted through software by means of a special programmer, or by means of a computer through the RS 232 interface. The correct function of the digital control unit is signaled by a green LED. The incorrect function (failure) is indicated by a red LED.

As a standard, the proportional valve is delivered with factory setting. The model including also an external feedback shall be consulted with the manufacturer.

With the basic surface treatment, the valve housing is phosphate coated, whereas the surfaces of the solenoids are zinc coated.

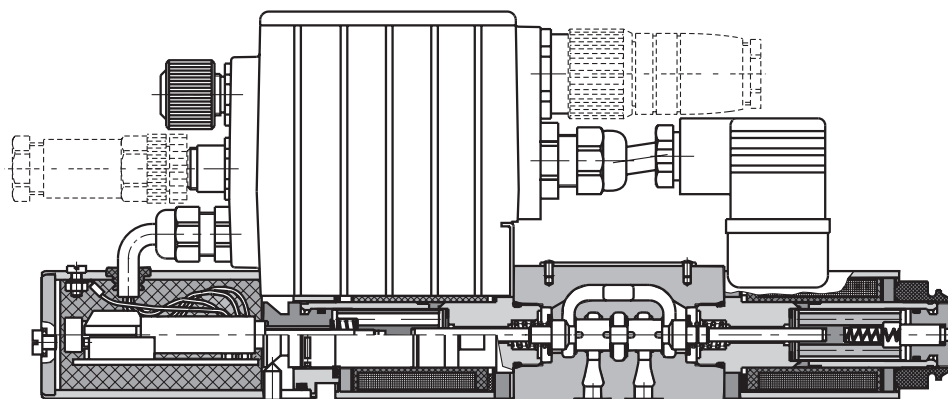

Ordering Code

PRM7-04 / -

Proportional Directional Control Valve

Seals

without designation
V

NBR
FPM (Viton)

Nominal size 04 (D 02)

Model

- S01** position sensor with voltage outlet
- S02** position sensor with current outlet
- E01** proportional directional valve without feedback
- E02S01** proportional directional valve with position feedback
- E03** proportional directional valve with external feedback
- E04S01** proportional directional valve with position and external feedback

Spool Symbols

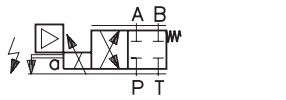

2Z51

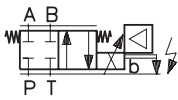

2Z11

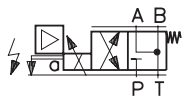

3Y51

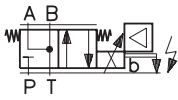

2Y11

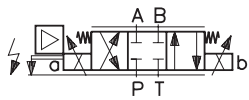

3Z11

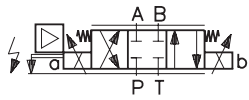

3Z12

$$\frac{q_A}{q_B} = \frac{1}{2}^*$$

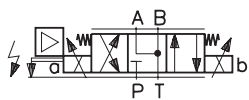

3Y11

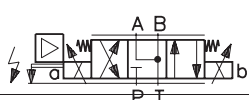

3Y12

$$\frac{q_A}{q_B} = \frac{1}{2}^*$$

Nominal solenoid supply voltage

- 12** **supply voltage 12 V DC
- 24** supply voltage 24 V DC

** Cannot be supplied as Variant S2

Nominal flow rate at Δp = 145 PSI (10 bar)

- 4** flow 4 L/min (1.1 GPM)
- 8** flow 8 L/min (2.1 GPM)
- 12** flow 12 L/min (3.2 GPM)

* Model for cylinders with asymmetric piston rod, piston area ratio 1:2

Connectors are to be ordered **separately**, see ordering number on page 10

Technical Data		
Nominal size	mm (US)	04 (D 02)
Max. operating pressure at ports P, A, B	bar (PSI)	320 (4600)
Max. operating pressure at port T	bar (PSI)	210 (3046)
Hydraulic fluid		Hydraulic oils of power classes (HL, HLP) to DIN 51524
Fluid temperature range (NBR / Viton)	°C (°F)	-30 ... +80 (-22 ... +176) / -20 ... +80 (-4 ... +176)
Ambient temperature max.	°C (°F)	+50 (+122)
Viscosity range	mm ² /s (SUS)	20 ... 400 (98 ... 1840)
Maximum degree of fluid contamination		Class 21/18/15 to ISO 4406
Nominal flow at $\Delta p = 10$ bar (145 PSI)	L/min (GPM)	4 (1.1) / 8 (2.1) / 12 (3.2)
Hysteresis - open loop	%	< 6
Hysteresis - closed position loop	%	< 0.5
Weight - PRM7-042 - PRM7-043	kg (lbs)	1.5 (3.30) 1.8 (3.96)
Mounting position		unrestricted
Enclosure type to EN 60529		IP65

Technical Data of Position Sensor - Voltage Outlet

Operating pressure	bar (PSI)	max. 320 (4600), static
Electric connection		electrical connector G4W1F Hirschmann *
Contact assignment		1 - Power supply 2 - Command signal 3 - GND 4 - not used
Enclosure type to EN 60529		IP65
Measured distance	mm (in)	8 (0.315)
Operating voltage	V	9.6 ...30 DC
Linearity error	%	< 1
Current consumption at load current of 2 mA	mA	< 15
Output voltage	V	0 ... 5
Output signal range used: 0 Position 1 solenoid - stroke 1.8 mm (0.07 in) 2 solenoids - stroke ± 1.8 mm (0.07 in)	V	2.5 1.375 - 2.5 1.375 - 3.625
Max. load current	mA	2
Noise voltage - at load current 0 - at load current of 2 mA	mV _{p-p}	< 20 < 15
Additional output signal error at: Temperature change between 0 ... 80 °C (32 ...176 °F) Between 0 ... -25 °C (32 ...-13 °F) Load change from 0 to 2 mA		typical < 0.2% / 10K max. 0.5% / 10K max. 0.5% / 10K 0.1%
Input voltage change from 9.6 V to 14.4 V from 14.4 V to 30 V	%	< 0.1 < 0.25
Long-term drift (30 days)	%	< 0.25
Cut-off frequency 3 dB fall in amplitude Frequency 90°	Hz	> 600 > 600

* Only for S01 and S02 model.

Technical Data of Position Sensor - Current Outlet

Linearity	%	< 1
Operating pressure	bar (PSI)	to 320 (4600), static
Electrical connection		electrical connector G4W1F Hirschmann *
Contact assignment		1 - Power supply 2 - Command signal 3 - GND 4 - not used
Enclosure type to EN 60529		IP65
Operatin voltage	V	20 ... 30 DC
Current	mA	< 35
Output signal range	mA	4 20
Output signal range used: 0 position 1 solenoid -stroke 1.8 mm (0.07 in) 2 solenoids - stroke ± 1.8 mm (0.07 in)	mA	12 8.4 ... 12 8.4 ... 15.6
Additional output signal error: - at temperature change from +10 ... 55 °C (50 ... 131 °F) - at impedance change from 50% - at input voltage change in the range of operating voltage		0.2% / 10K ≤ 0.1% ≤ 0.05%
Impedance	Ω	≤ 500
Output signal ripple	mA R.M.S.	≤ 0.02
Limit frequency at 3 dB amplitude decrease	Hz	≥ 800

* Only for S01 and S02 model.

Technical Data of Proportional Solenoid

Type of coil	V	12 DC	24 DC
Limiting current	A	1.7	0.8
Resistance at 20 °C (68 °F)	Ω	4.9	21

Electronics Data

Supply voltage with polarity inversion protection	V	11.2 ... 28 VDC (residual ripple < 10%)
Input: command signal / according to customer setting		±10V, 0 ... 10V, ±10mA, 4...20mA, 0...20mA, 12mA ± 8mA
Input: spool position sensor signal		0...5V
Input: external feedback signal		0...10V, 4...20mA, 0...20mA,
Resolution of the A/D converter		12 bit
Output: solenoids		Two PWM output stages up to max. 3.5 A
PWM frequency	kHz	18
Adjustment of parameters	μs	170
EMC	Interference resistance	61000 - 6 - 2 : 2005
	Radiation resistance	55011 : 1998 class A

Parameter setting	Serial port RS 232 (zero modem). 19200 bauds, 8 data bits, 1 stop bit, no parity. Special software PRM7Conf.
-------------------	-----------------------------------------------------------------------------------------------------------------

Accessories

Order number	Content
23093400	Connecting cable to PC - length 2m (6.56ft), CD-ROM with program PRM7Conf and user manual.
23093500	Connecting cable to PC - length 5m (16.40ft), CD-ROM with program PRM7Conf and user manual.
24523400	Connecting cable to PC - length size 2m (6.56ft).
24523500	Connecting cable to PC - length size 5m (16.40ft).

Limit Power

Measured at $v = 32 \text{ mm}^2/\text{s}$ (156 SUS)

Only for E01 model

$P \rightarrow A / B \rightarrow T$ or $P \rightarrow B / A \rightarrow T$

Nominal flow 4 L/min (1.1 GPM)

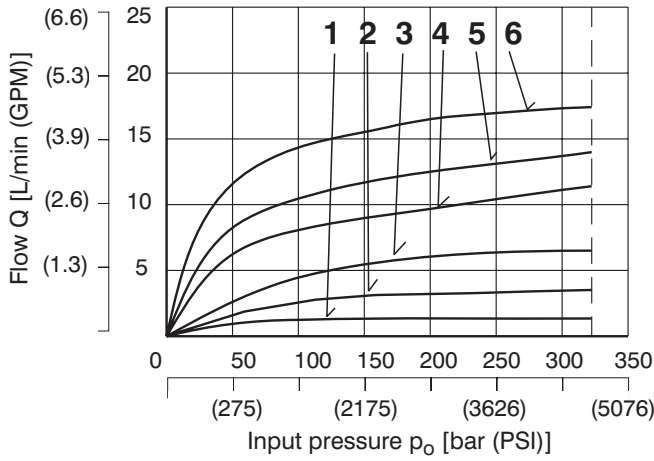

Nominal flow 8 L/min (2.1 GPM)

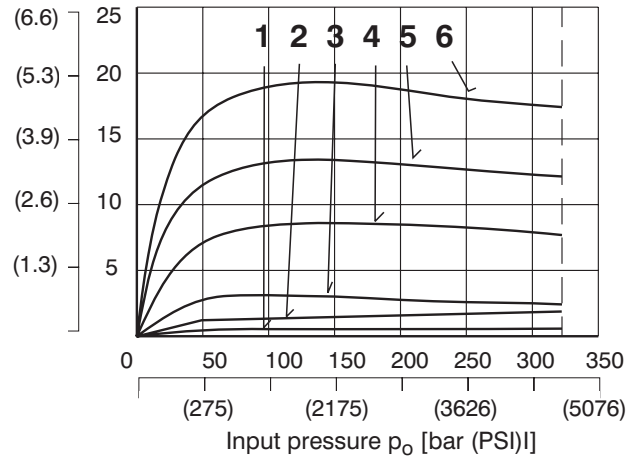

Nominal flow 12 L/min (3.2 GPM)

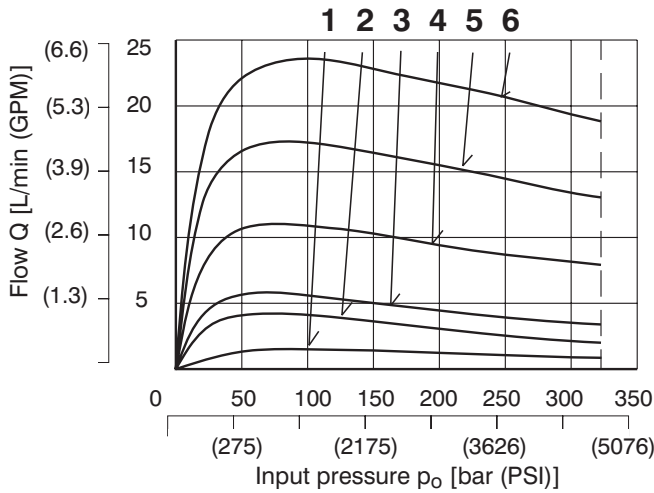

Solenoid current:

- 1 = 50%
- 2 = 60%
- 3 = 70%
- 4 = 80%
- 5 = 90%
- 6 = 100%

Flow Characteristics

Measured at input pressure $\Delta p = 10 \text{ bar}$ (145 PSI), $v = 32 \text{ mm}^2/\text{s}$ (156 SUS)

Only for E01 model

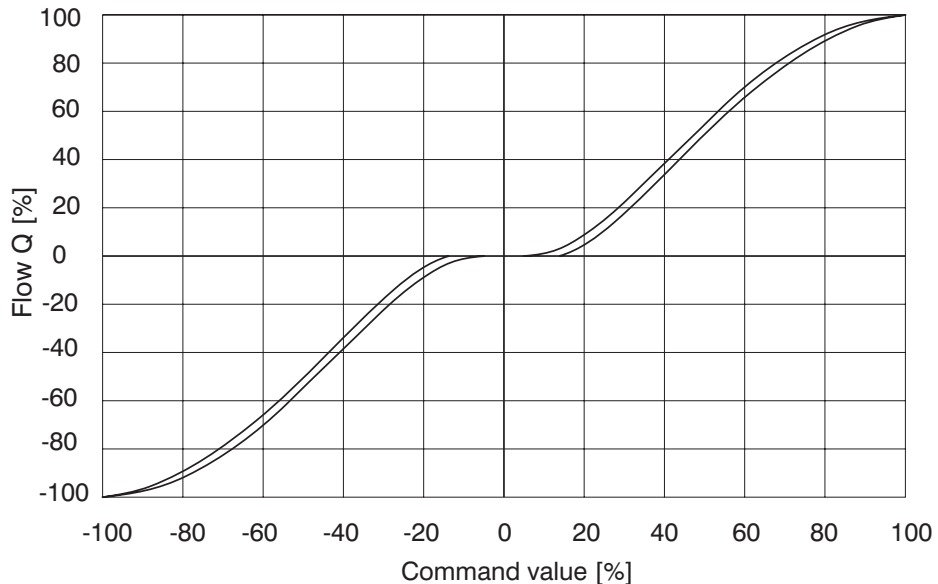

6

Flow Characteristics

Measured at $v = 32 \text{ mm}^2/\text{s}$ (156 SUS)

Only for E02S01 model

$Q_n = 4 \text{ L/min}$ (1.1 GPM) by $\Delta p = 10 \text{ bar}$ (145 PSI)

Δp = Valve pressure differential (inlet pressure p_V minus load pressure and return pressure p_T)

Δp_n = Valve pressure differential for nominal flow Q_n

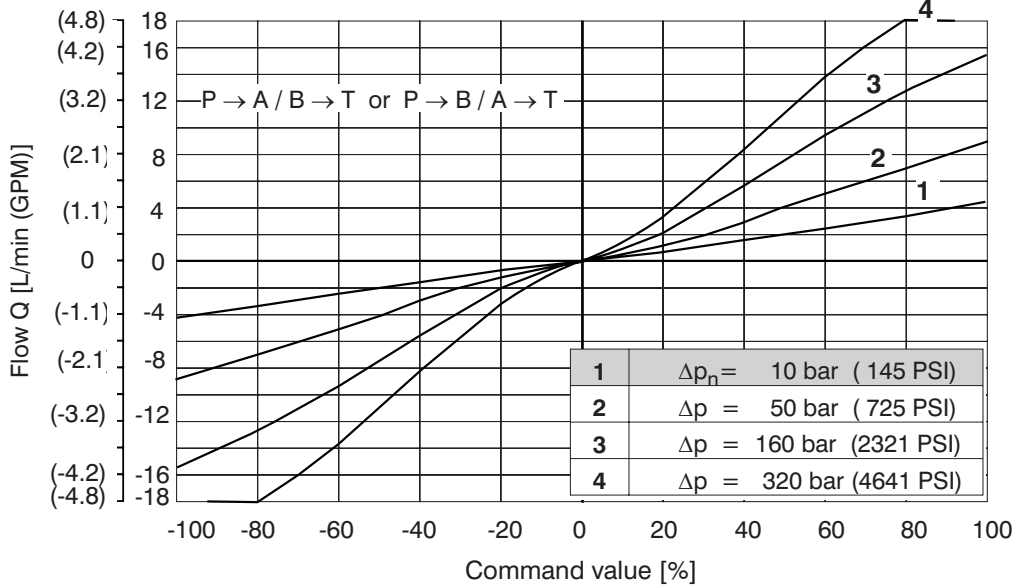

Only for E02S01 model

$Q_n = 8 \text{ L/min}$ (2.1 GPM) by $\Delta p = 10 \text{ bar}$ (145 PSI)

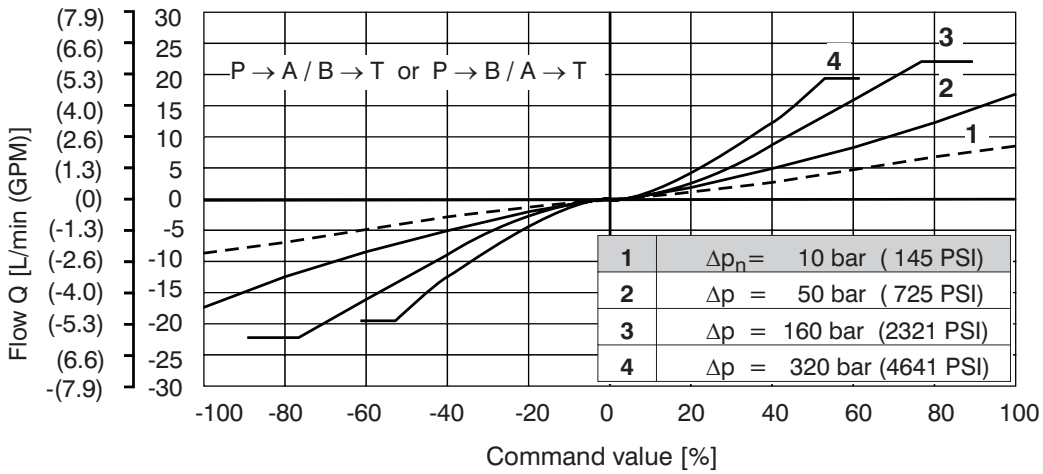

Only for E02S01 model

$Q_n = 12 \text{ L/min}$ (3.2 GPM) by $\Delta p = 10 \text{ bar}$ (145 PSI)

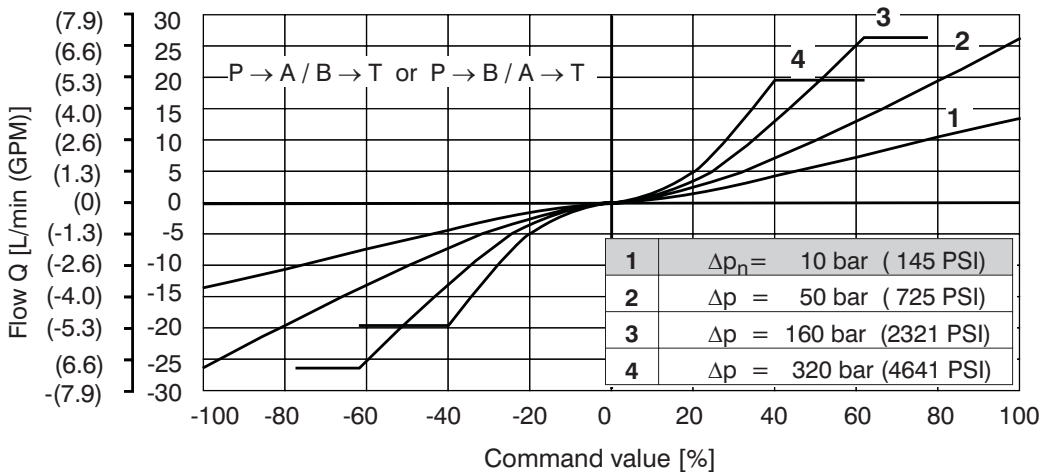

Frequency Reponse

closed position loop, for E02S01 model

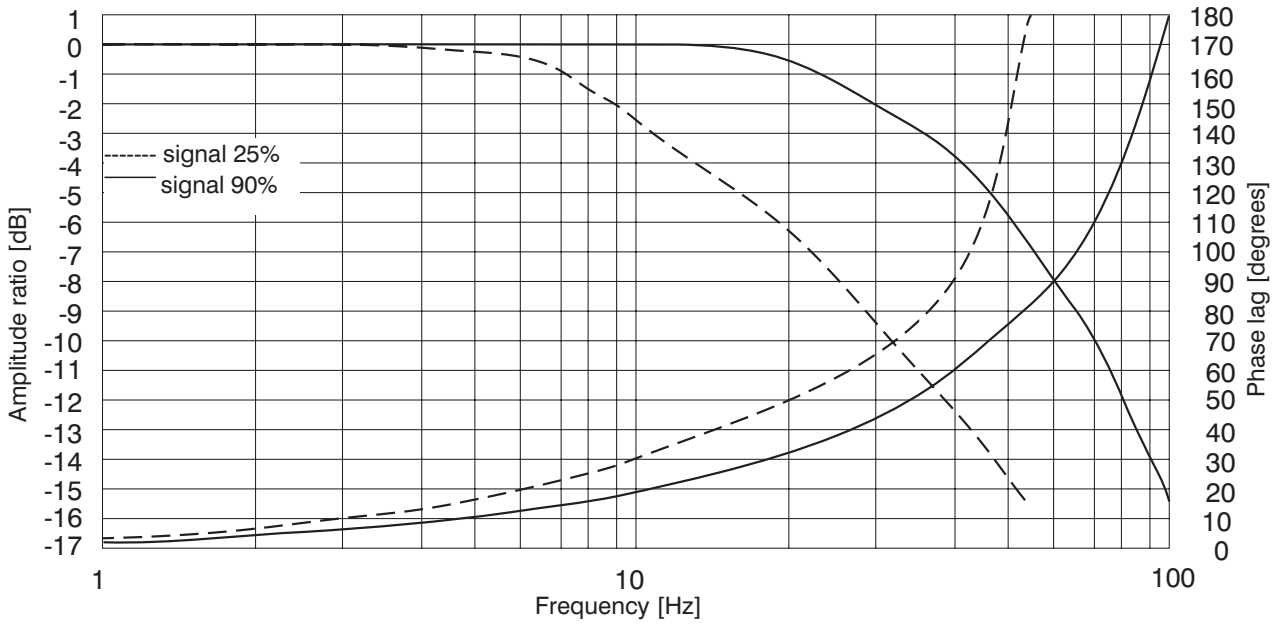

Connector Connection

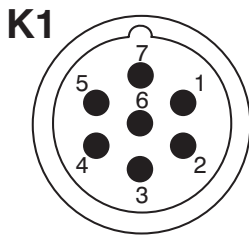

Connector K1 - type M23 (male)

PIN	Technical data	Description
1	* Power supply input	11.2 ... 28V DC
2	* Ground (power supply)	0V
3	Control signal	according to configuration
4	Ground (signal)	0V
5	Power reference signal	+10V DC/max.10mA
6	Control signal of position sensor spool	0 ...5V
7	* Protection earth lead (PE)	---

* Recommended min. lead cross section 0.75mm²

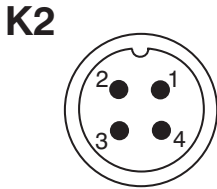

Connector K2 - type M12x1 (male)

PIN	Technical data	Description
1	TxD	standard
2	RxD	RS 232
3	Ground (signal)	0V
4	Not used	

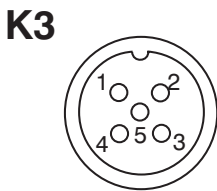

Connector K3 - type M12x1 (female)

PIN	Technical data	Description
1	Power supply output	11.2 ... 28V DC/max.100mA
2	Signal of external feedback	according to configuration
3	Ground	0V
4	Not used	
5	Not used	

K2 - Connection RS232 M12x1 (4 PIN)
For programming the electronics.

K1 - Main input connector M23 (7PIN)
Cable diameter 8 ...12mm (0.31...0.47in).

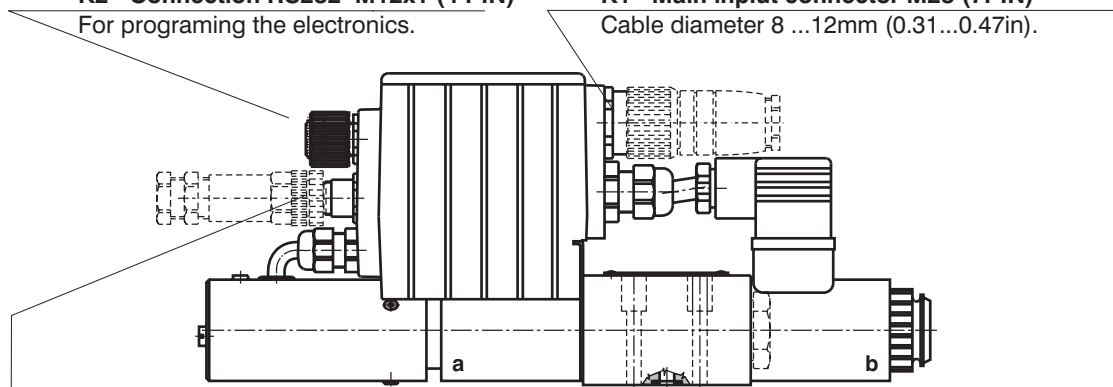

K3 - Conektor M12x1 (5PIN)

External feedback signal (it presented only for E03 and E04S01 configurations).

6

Factory Settings

Item	Model							
	E01		E02S01		E03		E04S01	
	1 Magnet	2 Magnet	1 Magnet	2 Magnet	1 Magnet	2 Magnet	1 Magnet	2 Magnet
Control signal	0...10 V	± 10 V	0...10 V	± 10 V	0...10 V	± 10 V	0...10V	± 10 V
Signal external feedback	-	-	-	-	0...10 V			
Output position sensor spool	-	-	0...5 V		-		0...5 V	

Valve Dimensions

Dimensions in millimeters (inches)

043 ... S01
043 ... S02

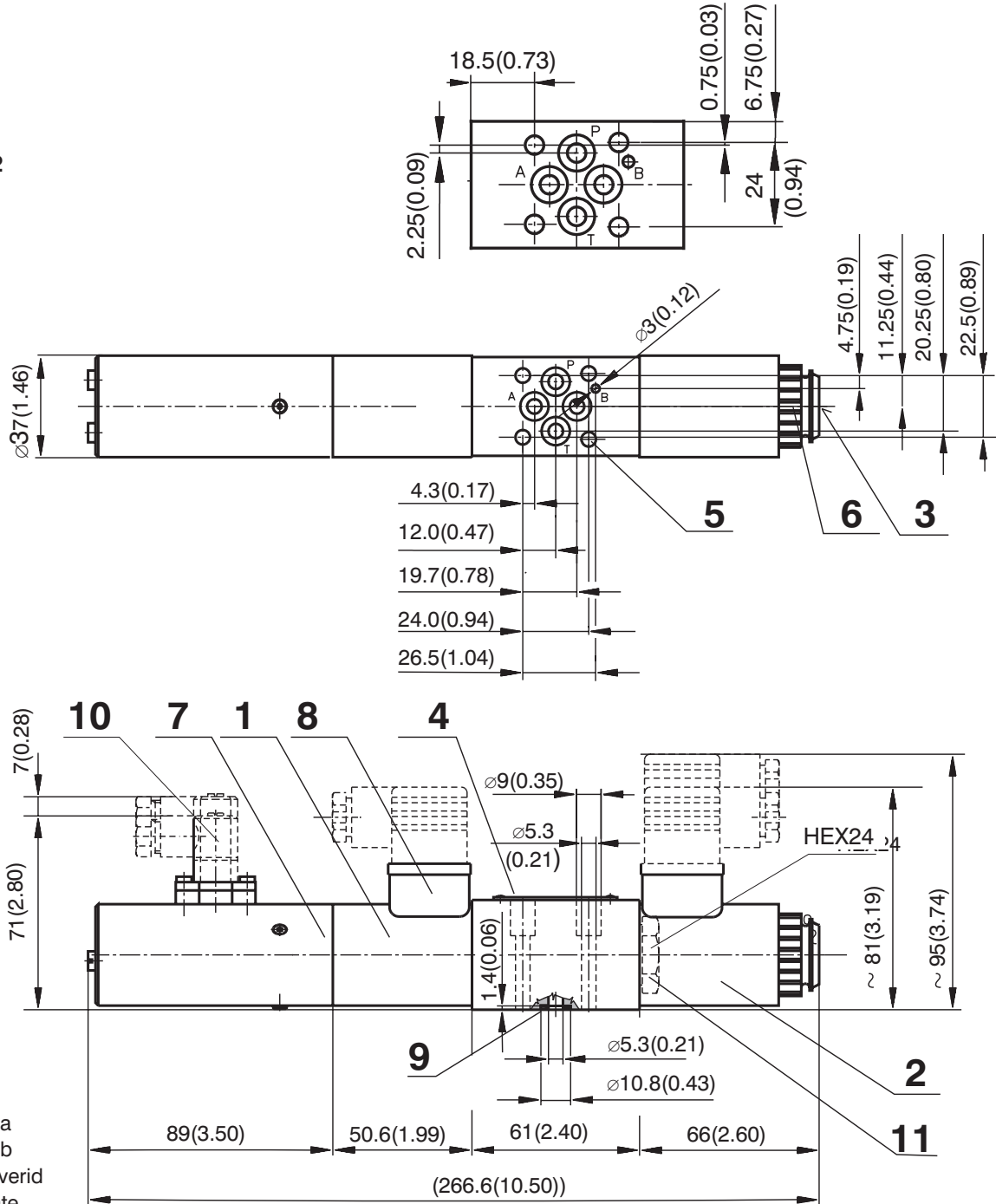

- 1 Solenoid a
- 2 Solenoid b
- 3 Manual overrid
- 4 Name plate
- 5 4 mounting holes
- 6 Solenoid fixing nut
- 7 Position sensor
- 8 Solenoid supply connector
- 9 Square ring 7.65 x 1.68 (4 pcs.), supplied in delivery packet
- 10 Position sensor connector
- 11 Plug screw for valve with one solenoid, HEX 24, configurations 2Z51, 2Z11

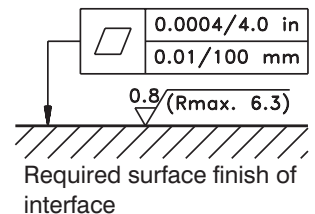

6

Valve Dimensions

Dimensions in millimeters (inches)

043 ... E01 - without connector plug for spool position feedback

043 ... E03

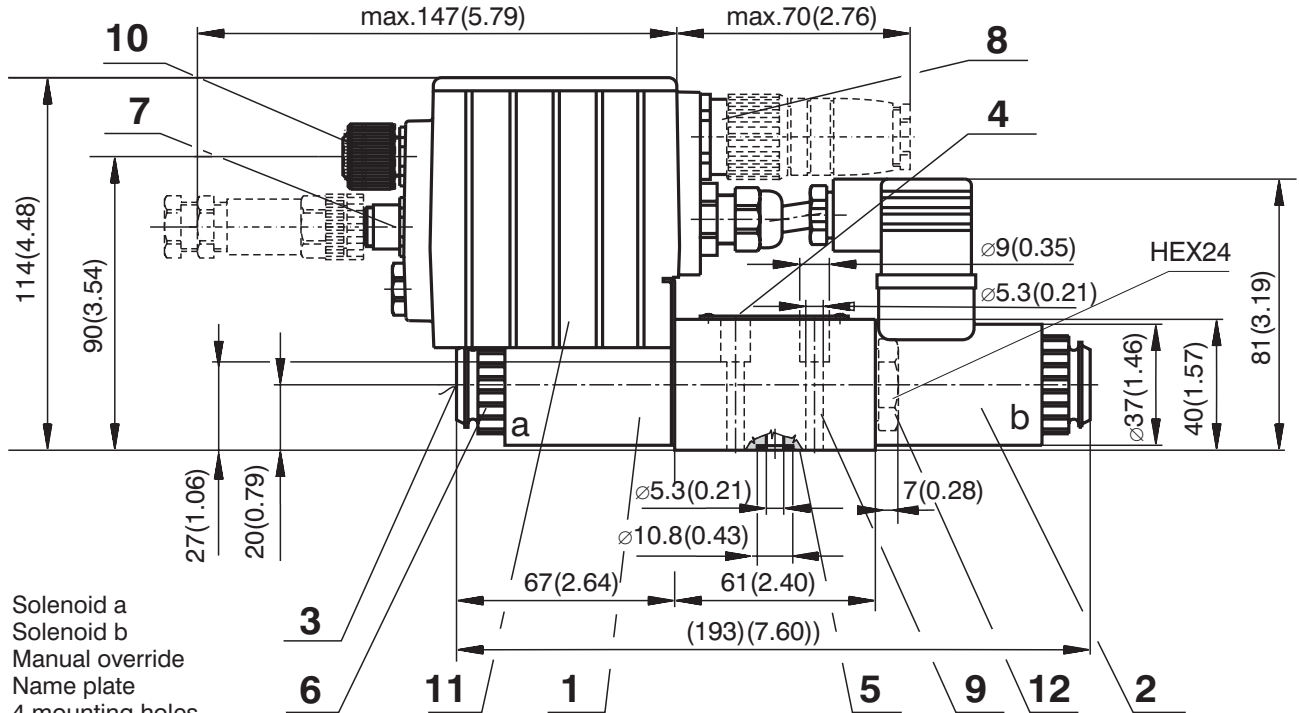

- 1 Solenoid a
- 2 Solenoid b
- 3 Manual override
- 4 Name plate
- 5 4 mounting holes
- 6 Solenoid fixing nut
- 7 Connector M12x1 for connection of external feedback
- 8 Main supply connector M23
- 9 Square ring 7.65 x 1.68 (4 pcs.), supplied in delivery packet
- 10 Cover of connector M12x1 for programming
- 11 Plastic box with integrated electronics
- 12 Plug screw for valve with one solenoid, HEX24, configurations 2Z51, 2Z11

043 ... E02S01 - without connector plug for spool position feedback

043 ... E04S01

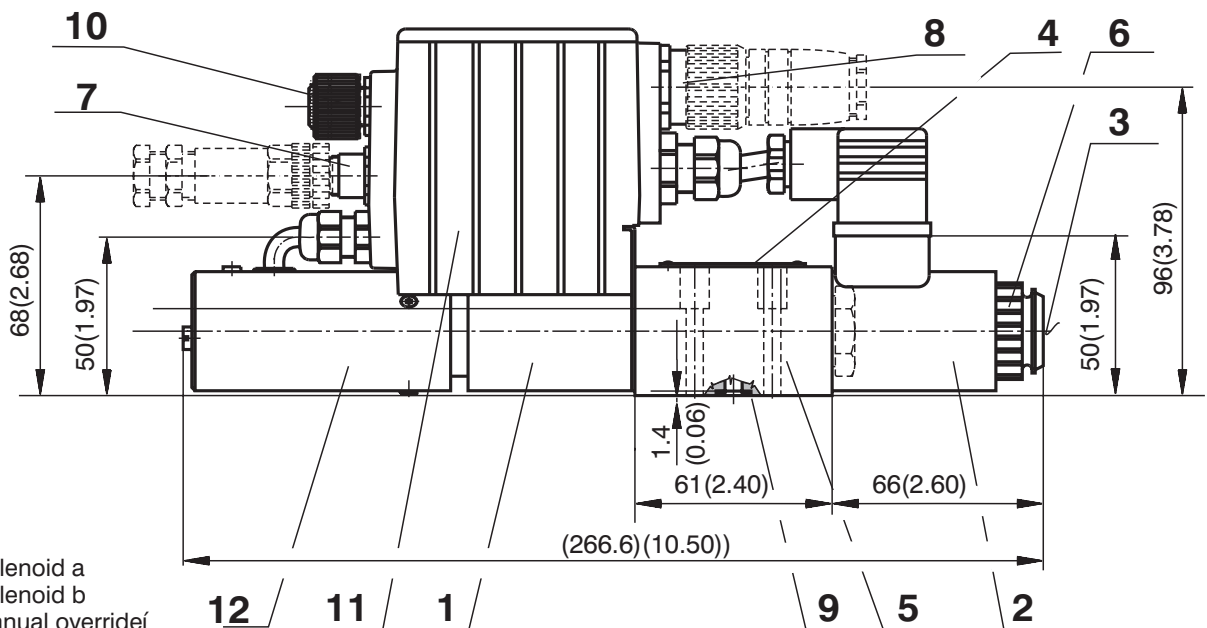

- 1 Solenoid a
- 2 Solenoid b
- 3 Manual override
- 4 Name plate
- 5 4 mounting holes
- 6 Solenoid fixing nut
- 7 Connector M12x1 for connection of external feedback
- 8 Main supply connector M23
- 9 Square ring 7.65 x 1.68 (4 pcs.), supplied in delivery packet
- 10 Cover of connector M12x1 for programming
- 11 Plastic box with integrated electronics
- 12 Position sensor

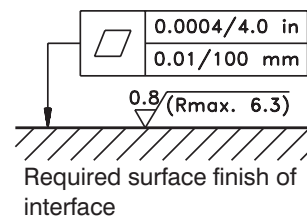

6

Spare Parts

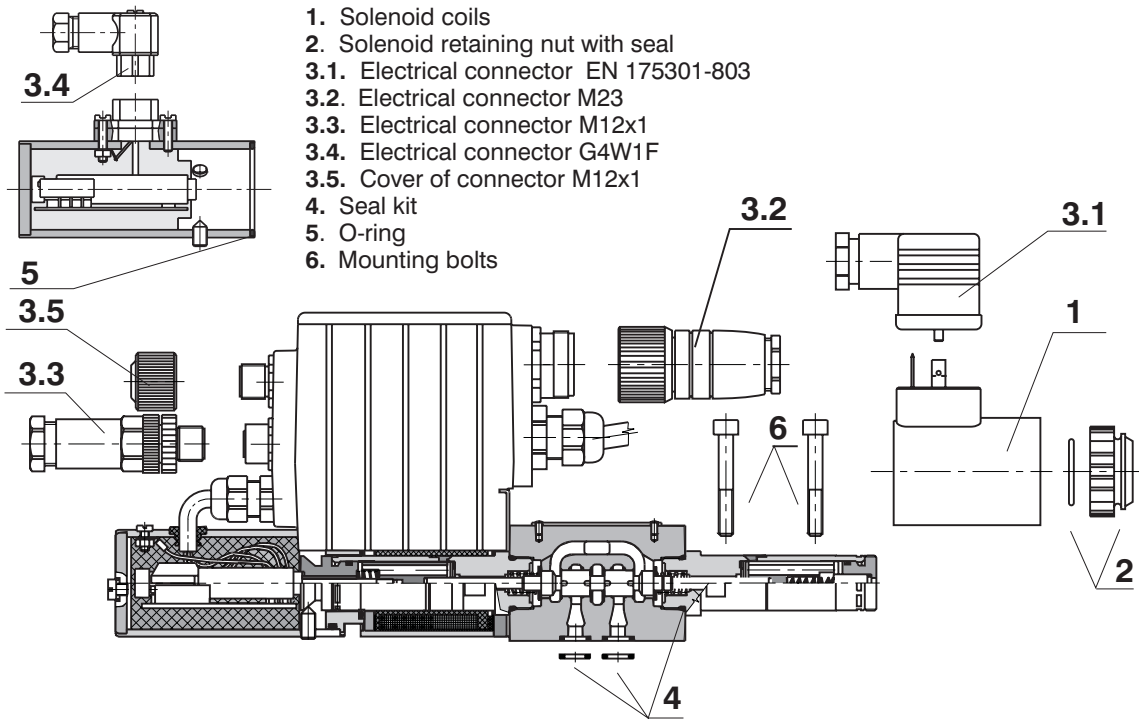

1. Solenoid coil

Solenoid type	Ordering number
01200	16186100
02400	16186200

2. Solenoid retaining nut with seal

Type of the nut	Seal ring	Ordering number
Standard nut	18 x 1.5	15874500

3.1. Electrical connector EN 175301-803

Type designation	Type	Maximum input voltage	Connector A	Connector B
			grey	black
			Ordering number	
K5	without rectifier - M16x1.5 (bushing bore \varnothing 4-6 mm)	230 V DC	16202600	16202500

3.2. Electrical connector M23 - 7PIN (female)

Ordering number	345579500001
-----------------	--------------

3.3. Electrical connector M12x1- 5PIN (male), it presented only for E03 and E04S01 configurations

Ordering number	358359000002
-----------------	--------------

3.4. Electrical connector G4W1F

Ordering number	358358932157
-----------------	--------------

3.5. Cover of connector M12x1

Ordering number	23090600
-----------------	----------

4. Seal kit

Type	Dimensions, number		Order number
	Square ring	O-ring	
Standard - NBR70	7.65 x 1.68 (4 pcs.)	16 x 2,0 (2 pcs.)	15873800
Viton	7.65 x 1.68 (4 pcs.)	16 x 2.0 (2 pcs.)	15874400

5. O-ring

Standard - NBR70	28 x 2 (1 pc.)	273111014120
------------------	----------------	--------------

6. Mounting bolts

Dimensions, number	Tightening torque	Ordering number
M5 x 35 DIN 912-10.9 (4 pcs.)	5 Nm (3.7 ft-lbs)	15874600

Caution!

- The packing foil is recyclable. The protective plate can be returned to manufacturer.
- The technical information regarding the product presented in this catalogue is for descriptive purposes only. It should not be construed in any case as a guaranteed representation of the product properties in the sense of the law.

ARGO-HYTOS s.r.o, CZ - 543 15 Vrchlaví
 Tel.: +420-499-403111, Fax: +420-499-403421
 E-mail: sales.cz@argo-hytos.com
 www.argo-hytos.com

- Digital control
- Compact design
- Operated by proportional solenoids
- High sensitivity and slight hysteresis
- Installation dimensions to DIN 24 340 / ISO 4401 / CETOP RP121-H

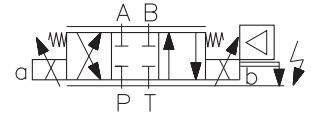
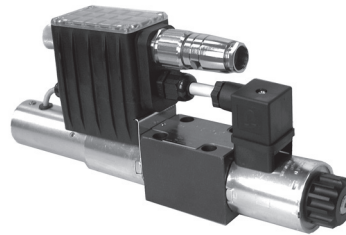

Functional Description

The proportional directional valve PRM7 consists of a cast iron housing, a special control spool, two centering springs with supporting washers, one or two proportional solenoids, a position sensor or, if need be, of a control box with digital electronics.

The measuring system of the position sensor consists of a differential transformer with core and from the evaluating electronic unit realized in hybrid technique.

With the model without integrated electronic unit, the electric connection of the solenoids is realized by the connector plug to EN 175301-803, with the position sensor output being connected by the G4W1F connector plug. Both connectors are supplied.

The proportional valve with the integrated electronic unit comprises an electronic control box that is mounted, together with the position sensor, on either of the solenoids. The connection of the position sensor with the control box is provided by a cable. With the model with two solenoids, the solenoid mounted opposite the control box is connected with the control box by means of a EN 175301-803, connector. The connection of the supply voltage, control signal, program input and external output of the position sensor is realized by a 5-pin connector (ELKA 5012). The connection of the external feedback is provided by a 5-pin connector, which also has three supply voltages +24 V, +10V and -5V for an external sensor available. The solenoid coils, including the control box, can be turned in a range of $\pm 90^\circ$. The digital control unit enables the proportional valve to be controlled on the basis of data required from two feedback circuits.

In this case the proportional valve can be used as follows:

1. Proportional directional valve
2. Only with the internal feedback from the spool position sensor.
3. Only with the external feedback (pressure sensor, position sensor, etc.).
4. With internal and external feedback.

The outlet current to the electromagnet coils is controlled with the help of PWM. The electronic system is equipped with an internal current feedback. The outlet current in case of need may be modulated with the use of a signal of dynamic lubrication. Single function parameters are set up with the use of appropriate software with the help of a computer connected to the proportional switchboard through a serial interface RS 232.

It is necessary to order a cable in accordance with appropriate ordering number as mentioned on page 4.

The digital control unit utilizes the pulse-width-modulation (PWM) and supplies the solenoids with current proportional to the control signal. The supply current is additionally modulated with a dither frequency. The individual functional parameters are adjusted through software by means of a special programmer, or by means of a computer through the RS 232 interface. The correct function of the digital control unit is signaled by a green LED. The incorrect function (failure) is indicated by a red LED.

As a standard, the proportional valve is delivered with factory setting. The model including also an external feedback shall be consulted with the manufacturer.

With the basic surface treatment, the valve housing is phosphate coated, whereas the surfaces of the solenoids are zinc coated.

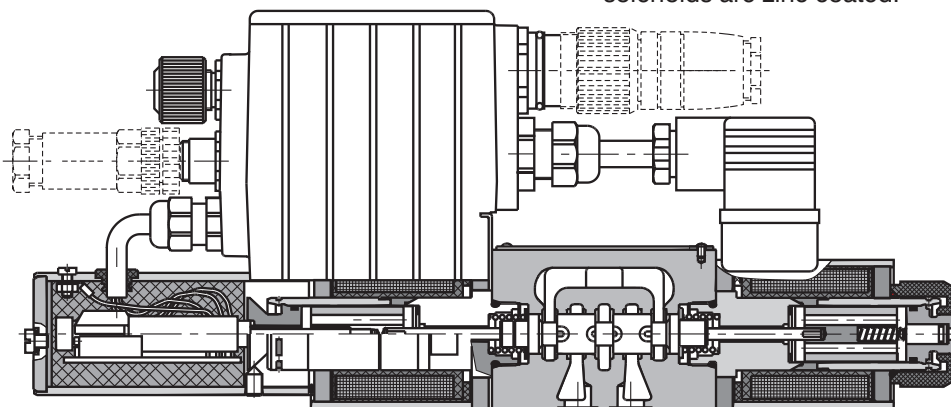

Ordering Code

PRM7-06 / -

Proportional directional control valve

without designation V

Seals

NBR
FPM (Viton)

Nominal size 06 (D 03)

Spool Symbols

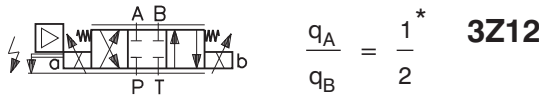
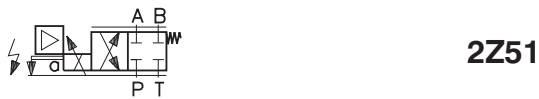

$$\frac{q_A}{q_B} = \frac{1}{2}^*$$

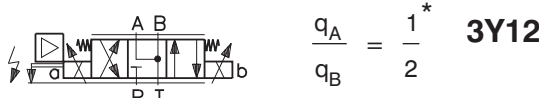

$$\frac{q_A}{q_B} = \frac{1}{2}^*$$

- Model**
- S01** position sensor with voltage outlet
 - S02** position sensor with current outlet
 - E01** proportional directional valve without feedback
 - E02S01** proportional directional valve with position feedback
 - E03** proportional directional valve with external feedback
 - E04S01** proportional directional valve with position and external feedback

Nominal solenoid supply voltage

12
24

**supply voltage 12V DC
supply voltage 24V DC

** Cannot be supplied as Variant S2

Nominal flow rate at Δp = 10 bar (145 PSI)

15
30

flow 15 L/min (3.96 GPM)
flow 30 L/min (7.93 GPM)

* Model for cylinders with asymmetric piston rod, piston area ratio 1:2

Connectors are to be ordered **separately**,
see ordering number on page 10

6

Technical Data		
Nominal size	mm (US)	06 (D 03)
Max. operating pressure at ports P, A, B	bar (PSI)	350 (5076)
Max. operating pressure at port T	bar (PSI)	210 (3046)
Hydraulic fluid		Hydraulic oils of power classes (HL, HLP) to DIN 51524
Fluid temperature range (NBR / Viton)	°C (°F)	-30 ... +80 (-22 ... +176) / -20 ... +80 (-4 ... +176)
Ambient temperature max.	°C (°F)	+50 (+122)
Viscosity range	mm ² /s (SUS)	20 ... 400 (98 ... 1840)
Maximum degree of fluid contamination		Class 21/18/15 to ISO 4406 (1999)
Nominal flow at $\Delta p = 10$ bar (145 PSI)	L/min (GPM)	15 (3.96) / 30 (7.93)
Hysteresis - open loop	%	< 6
Hysteresis - closed position loop	%	< 0.5
Weight - PRM7-062 - PRM7-063	kg (lbs)	2.3 (5.07) 2.8 (6.17)
Mounting position		optional
Enclosure type to EN 60 529		IP65

Technical Data of Position Sensor - Voltage Outlet

Operating pressure	bar (PSI)	max. 350 (5076), static
Electric connection		electrical connector G4W1F Hirschmann *
Contact assignment		1 - Power supply 2 - Command signal 3 - GND 4 - not used
Enclosure type to EN 60529		IP65
Measured distance	mm (in)	8 (0.315)
Operating voltage	V	9.6 ...30 DC
Linearity error	%	< 1
Current consumption at load current of 2 mA	mA	< 15
Output voltage	V	0 ... 5
Output signal range used: 0 Position 1 solenoid - stroke 2.8 mm (0.11 in) solenoids - stroke ± 2.8 mm (0.11 in)	V	2.5 0.75 - 2.5 0.75 - 4.025
Max. load current	mA	2
Noise voltage - at load current 0 - at load current of 2 mA	mV _{p-p}	< 20 < 15
Additional output signal error at: Temperature change between 0 ... 80 °C (32 ...176 °F) Between 0 ... -25 °C (32 ...-13 °F) Load change from 0 to 2 mA		typical < 0.2% / 10K max. 0.5% / 10K max. 0.5% / 10K 0.1%
Input voltage change from 9.6 V to 14.4 V from 14.4 V to 30 V	%	< 0.1 < 0.25
Long-term drift (30 days)	%	< 0.25
Cut-off frequency 3 dB fall in amplitude Frequency 90°	Hz	> 600 > 600

* Only for S01 and S02 model.

Technical Data of Position Sensor - Current Outlet

Linearity	%	< 1
Operating pressure	bar (PSI)	to 350 (5076), static
Electrical connection		electrical connector G4W1F Hirschmann *
Contact assignment		1 - Power supply 2 - Command signal 3 - GND 4 - not used
Enclosure type to EN 60529		IP65
Operatin voltage	V	20 ... 30 DC
Current	mA	< 35
Output signal range	mA	4 20
Output signal range used: 0 position 1 solenoid - stroke 2.8 mm (0.11 in) 2 solenoids - stroke ± 2.8 mm (0.11 in)	mA	12 4.4 ... 12 4.4 ... 19.6
Additional output signal error: - at temperature change from +10 ... 55 °C (50 ...131 °F) - at impedance change from 50% - at input voltage change in the range of operating voltage		0.2% / 10K ≤ 0.1% ≤ 0.05%
Impedance	Ω	≤ 500
Output signal ripple	mA R.M.S.	≤ 0.02
Limit frequency at 3 dB amplitude decrease	Hz	≥ 800

* Only for S01 and S02 model.

Technical Data of Proportional Solenoid

Type of coil	V	12 DC	24 DC
Limiting current	A	2.4	1.0
Resistance at 20 °C (68 °F)	Ω	2.3	13.4

Electronics Data

Supply voltage with polarity inversion protection	V	11.2 ... 28 VDC (residual ripple < 10%)
Input: command signal / according to customer setting		±10V, 0 ... 10V, ±10mA, 4...20mA, 0...20mA, 12mA ± 8mA
Input: spool position sensor signal		0...5V
Input: external feedback signal		0...10V, 4...20mA, 0...20mA,
Resolution of the A/D converter		12 bit
Output: solenoids		Two PWM output stages up to max. 3.5 A
PWM frequency	kHz	18
Adjustment of parameters	μs	170
EMC	Interference resistance	61000 - 6 - 2 : 2005
	Radiation resistance	55011 : 1998 class A

Parameter setting	Serial port RS 232 (zero modem). 19200 bauds, 8 data bits, 1 stop bit, no parity. Special software PRM7Conf.
-------------------	-----------------------------------------------------------------------------------------------------------------

Accessories

Order number	Content
23093400	Connecting cable to PC - length 2m (6.56ft), CD-ROM with program PRM7Conf and user manual.
23093500	Connecting cable to PC - length 5m (16.40ft), CD-ROM with program PRM7Conf and user manual.
24523400	Connecting cable to PC - length size 2m (6.56ft).
24523500	Connecting cable to PC - length size 5m (16.40ft).

Limit Power

Measured at $v = 32 \text{ mm}^2/\text{s}$ (156 SUS)

Only for E01 model

Nominal flow 15 L/min (3.96 GPM)

$P \rightarrow A / B \rightarrow T$ or $P \rightarrow B / A \rightarrow T$

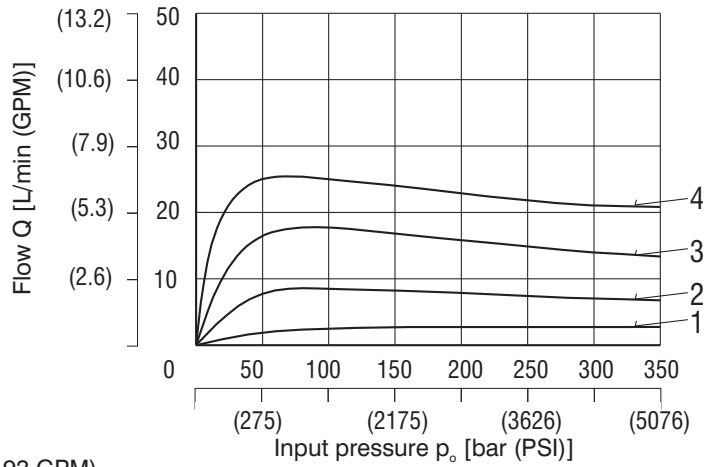

Nominal flow 30 L/min (7.93 GPM)

$P \rightarrow A / B \rightarrow T$ or $P \rightarrow B / A \rightarrow T$

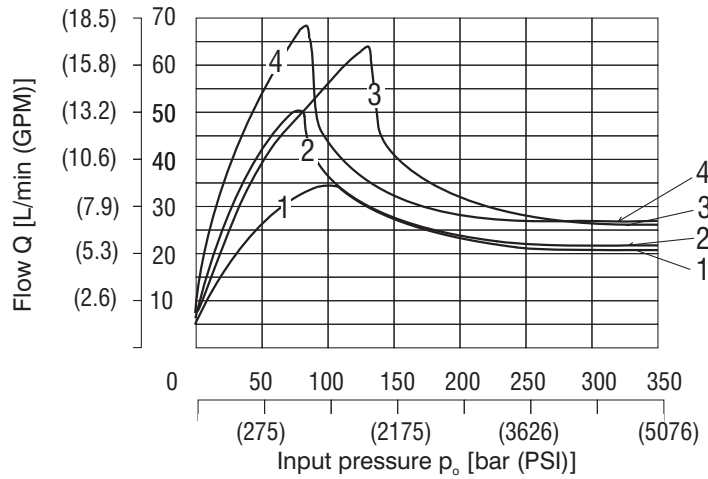

Solenoid current:
 1 = 40 %
 2 = 60 %
 3 = 80 %
 4 = 100 %

Flow Characteristics

Measured at input pressure $\Delta p = 10 \text{ bar}$ (145 PSI), $v = 32 \text{ mm}^2/\text{s}$ (156 SUS)

Only for E01 model

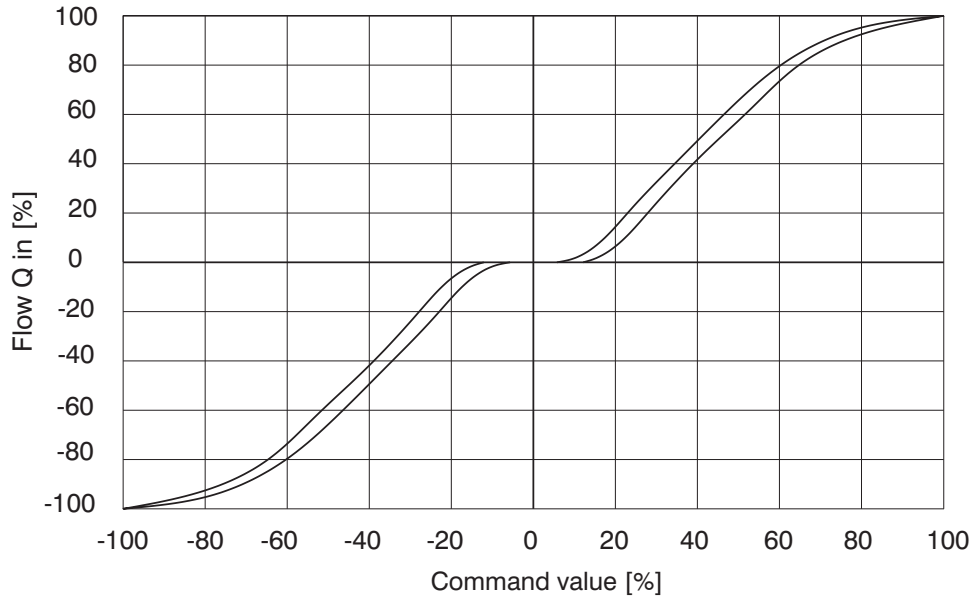

Flow Characteristics

Measured at $v = 32 \text{ mm}^2/\text{s}$ (156 SUS)

Only for E02S01 model

$Q_n = 15 \text{ L/min}$ (3.96 GPM) by $\Delta p = 10 \text{ bar}$ (145 PSI)

Δp = Valve pressure differential
(inlet pressure p_V minus load pressure and return pressure p_T)

Δp_n = Valve pressure differential for nominal flow Q_n

1	$\Delta p_n = 10 \text{ bar}$ (145 PSI)
2	$\Delta p = 50 \text{ bar}$ (725 PSI)
3	$\Delta p = 160 \text{ bar}$ (2321 PSI)
4	$\Delta p = 320 \text{ bar}$ (4641 PSI)

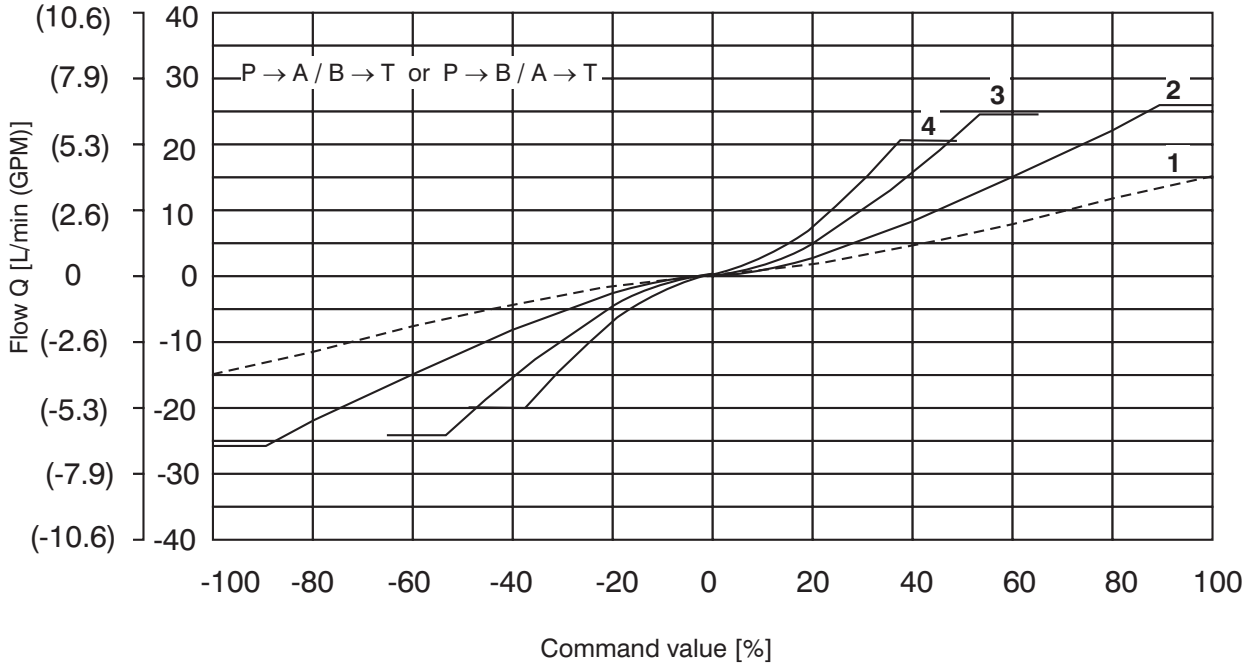

Only for E02S01 model

$Q_n = 30 \text{ L/min}$ (7.93 GPM) by $\Delta p = 10 \text{ bar}$ (145 PSI)

1	$\Delta p_n = 10 \text{ bar}$ (145 PSI)
2	$\Delta p = 50 \text{ bar}$ (725 PSI)
3	$\Delta p = 160 \text{ bar}$ (2321 PSI)
4	$\Delta p = 320 \text{ bar}$ (4641 PSI)

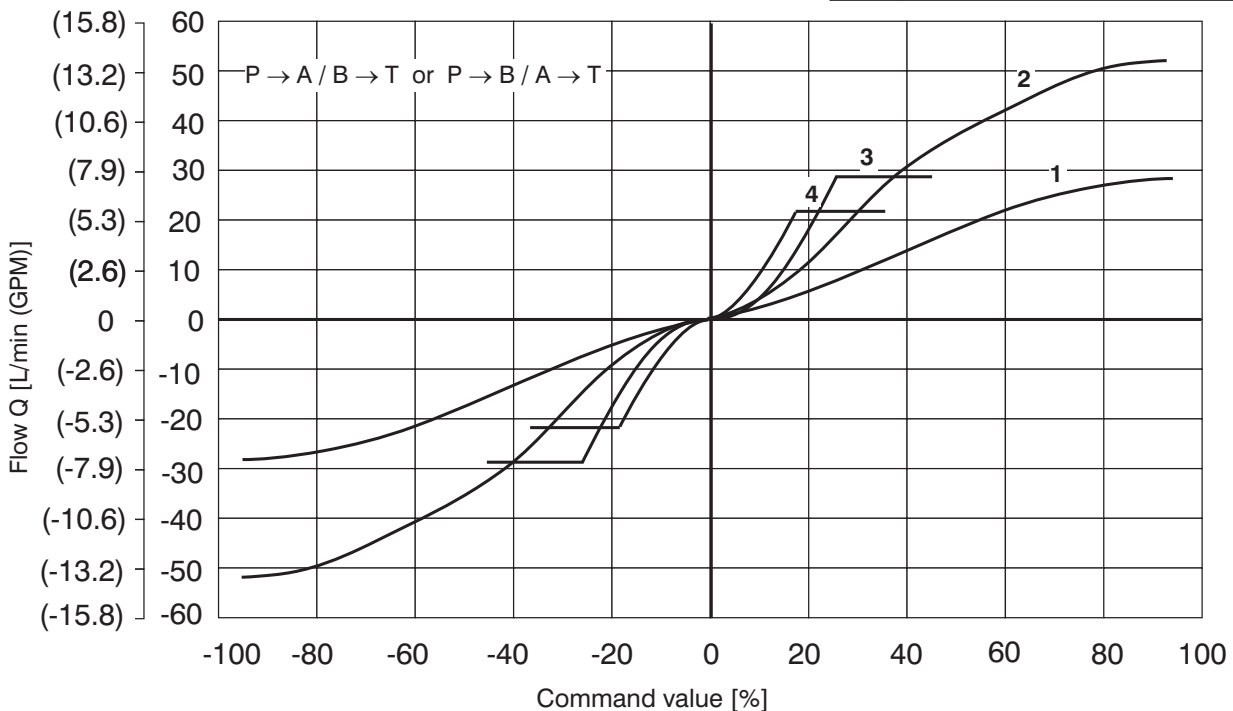

Frequency Reponse

closed position loop, for E02S01 model

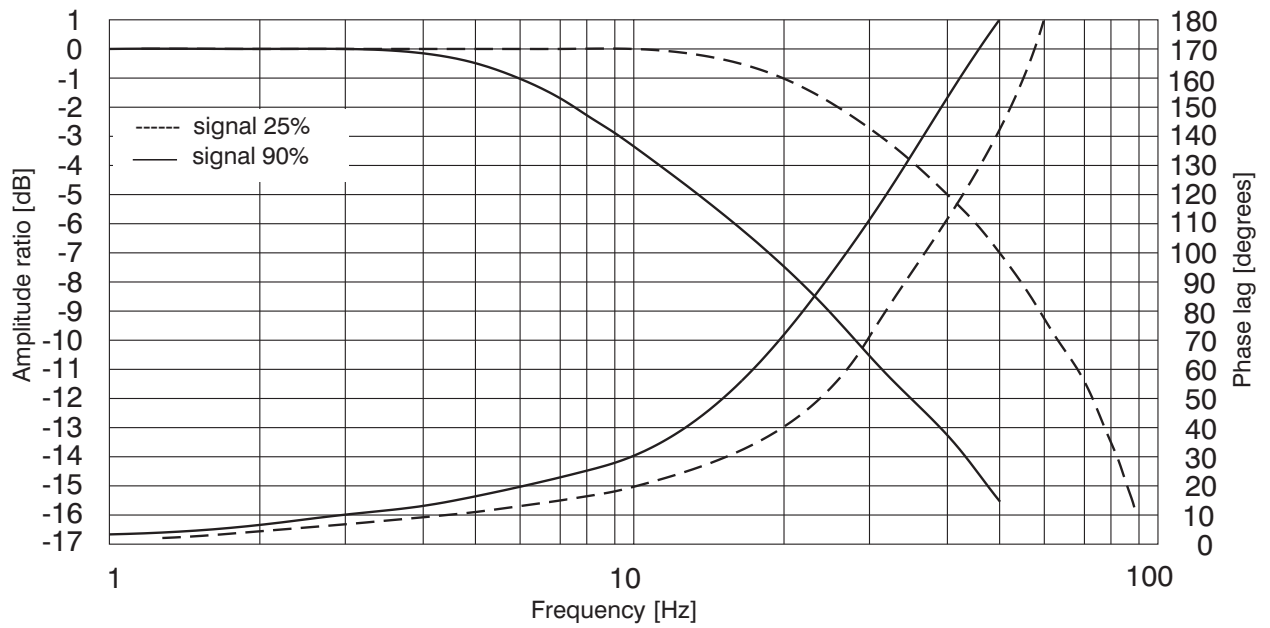

Connector Connection

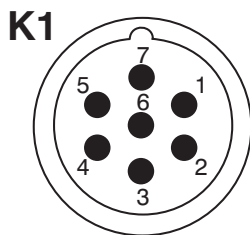

Connector K1- type M23 (male)		
PIN	Technical data	Description
1	* Power supply input	11.2 28V DC
2	* Ground (power supply)	0V
3	Control signal	according to configuration
4	Ground (signal)	0V
5	Power reference signal	+10V DC/max.10mA
6	Control signal of position sensor spool	0 ...5V
7	* Protection earth lead (PE)	---

* Recommended min. lead cross section 0.75mm²

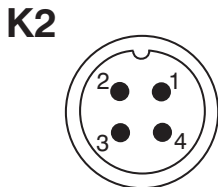

Connector K2 - type M12x1 (male)		
PIN	Technical data	Description
1	TxD	standard
2	RxD	RS 232
3	Ground (signal)	0V
4	Not used	

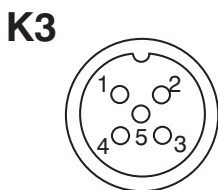

Connector K3 - type M12x1 (female)		
PIN	Technical data	Description
1	Power supply output	11.2 28V DC/max.100mA
2	Signal of external feedback	according to configuration
3	Ground	0V
4	Not used	
5	Not used	

K2 - Connection RS232 M12x1 (4 PIN)
For programming the electronics.

K1 - Main input connector M23 (7PIN)
Whole cable diameter 8 ...12mm (0.31...0.47in).

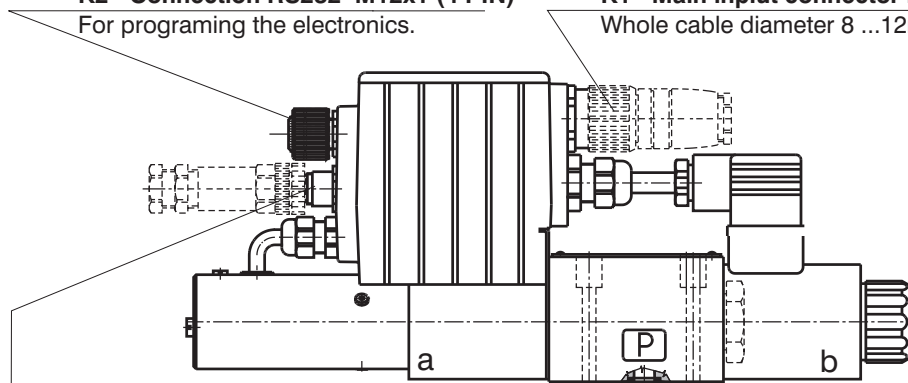

K3 - Conektor M12x1 (5PIN)
External feedback signal (it presented only for E03 and E04S01 configurations).

6

Manufactory valve configuration

Item	Model							
	E01		E02S01		E03		E04S01	
	1 Magnet	2 Magnet	1 Magnet	2 Magnet	1 Magnet	2 Magnet	1 Magnet	2 Magnet
Control signal	0...10 V	± 10 V	0...10 V	± 10 V	0...10 V	± 10 V	0...10V	± 10 V
Signal external feedback	-	-	-	-	0...10 V			
Output position sensor spool	-	-	0...5 V		-		0...5 V	

Valve Dimensions

Dimensions in millimeters and inches

063 ... S01

063 ... S02

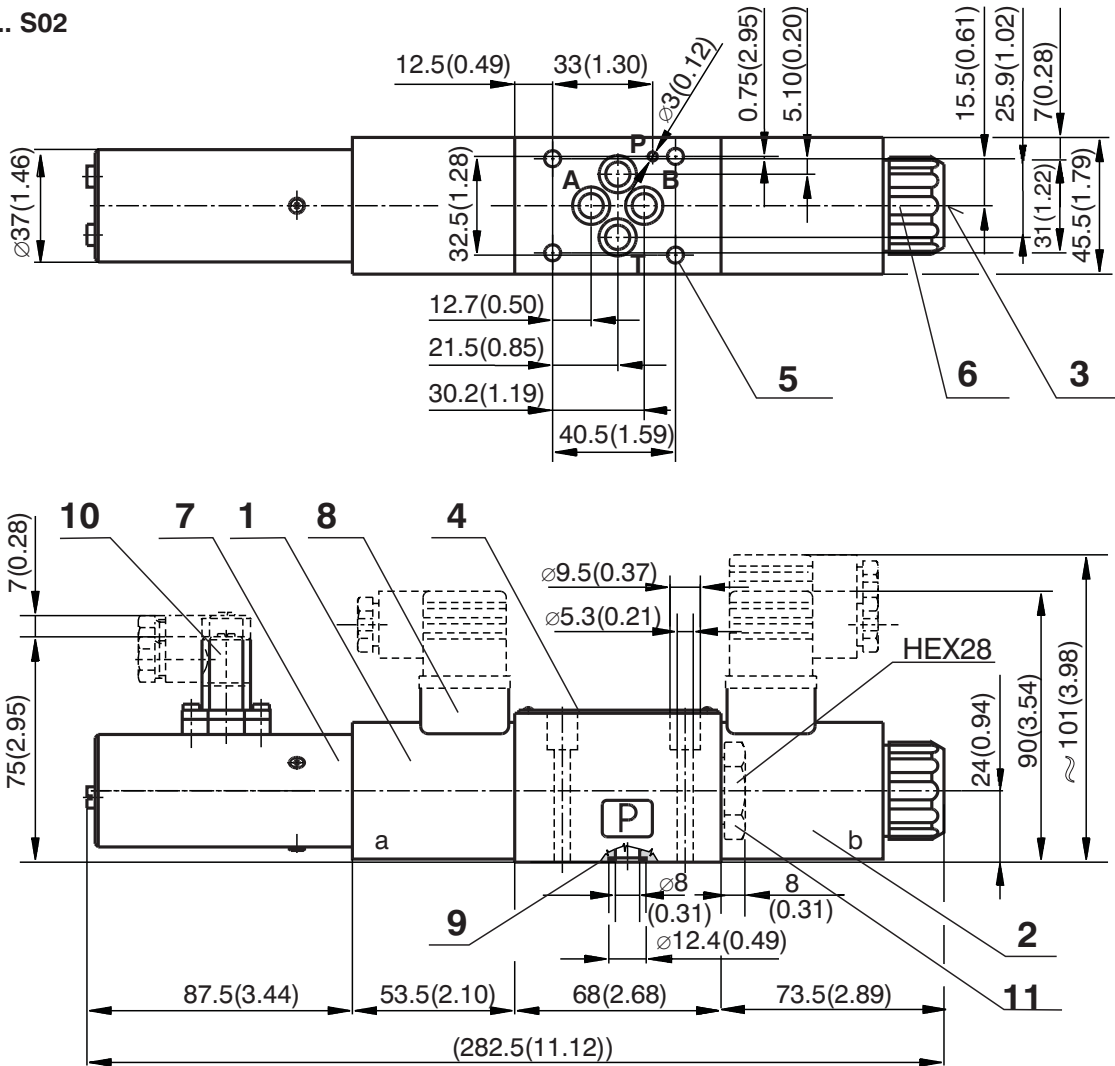

- 1 Solenoid a
- 2 Solenoid b
- 3 Manual overrid
- 4 Name plate
- 5 4 mounting holes
- 6 Solenoid fixing nut
- 7 Position sensor
- 8 Solenoid supply connector
- 9 Square ring 9.25 x 1.68 (4 pcs.), supplied in delivery packet
- 10 Position sensor connector
- 11 Plug screw for valve with one solenoid, HEX 28, configurations 2Z51, 2Z11

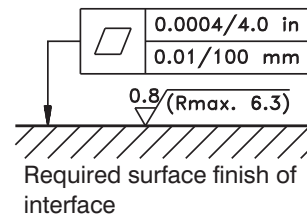

Valve Dimensions

Dimensions in millimeters and inches

063 ... E01 - without connector plug for spool position feedback

063 ... E03

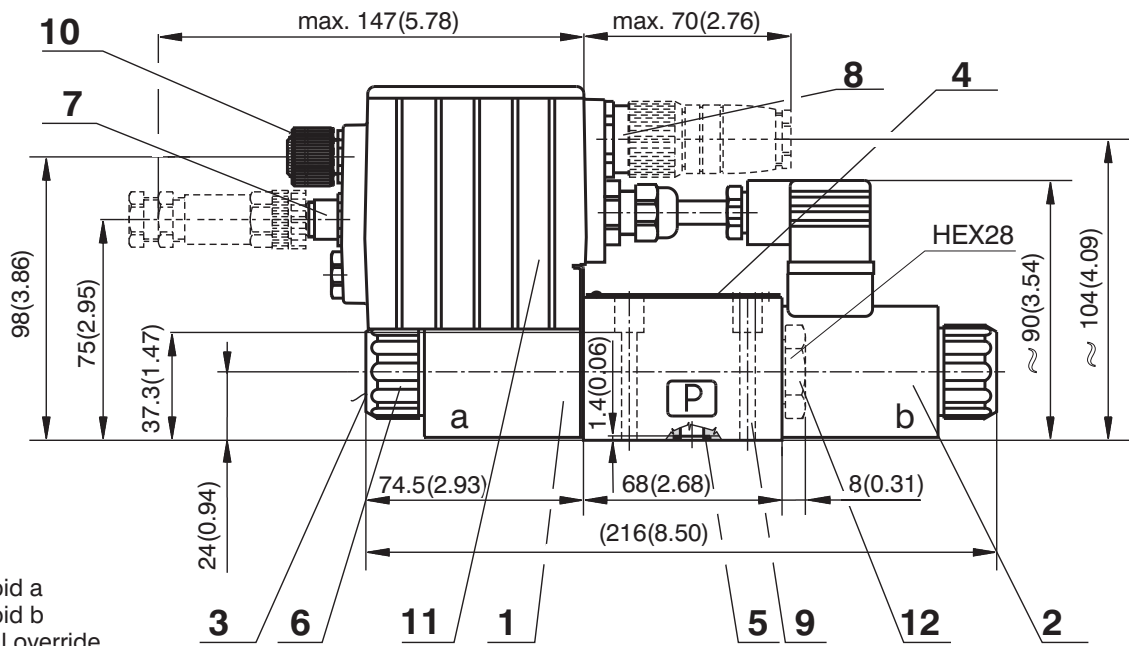

- 1 Solenoid a
- 2 Solenoid b
- 3 Manual override
- 4 Name plate
- 5 4 mounting holes
- 6 Solenoid fixing nut
- 7 Connector M12x1 for connection of external feedback
- 8 Main supply connector M23
- 9 Square ring 9.25 x 1.68 (4 pcs.), supplied in delivery packet
- 10 Cover of connector M12x1 for programming
- 11 Plastic box with integrated electronics
- 12 Plug screw for valve with one solenoid, HEX 28, configurations 2Z51, 2Z11

063 ... E02S01 - without connector plug for spool position feedback

063 ... E04S01

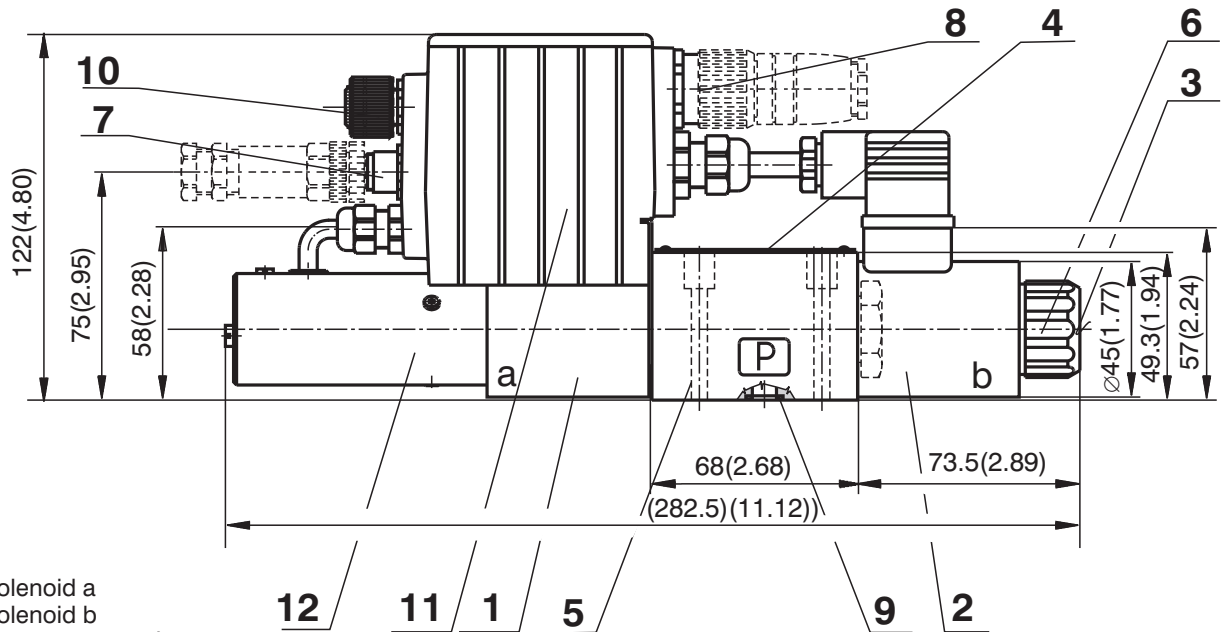

- 1 Solenoid a
- 2 Solenoid b
- 3 Manual override
- 4 Name plate
- 5 4 mounting holes
- 6 Solenoid fixing nut
- 7 Connector M12x1 for connection of external feedback
- 8 Main supply connector M23
- 9 Square ring 9.25 x 1.68 (4 pcs.), supplied in delivery packet
- 10 Cover of connector M12x1 for programming
- 11 Plastic box with integrated electronics
- 12 Position sensor

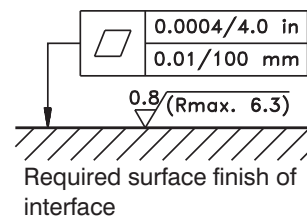

Spare Parts

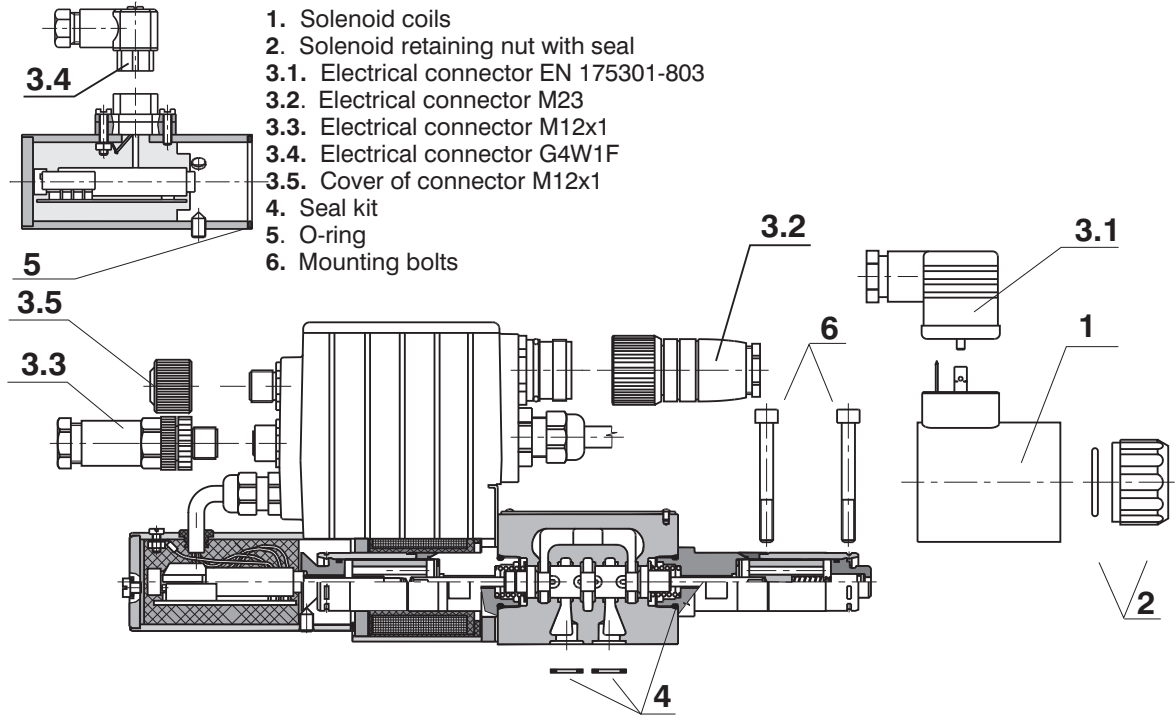

1. Solenoid coil				
Solenoid type		Ordering number		
01200		16186400		
02400		16186800		
2. Solenoid retaining nut with seal				
Type of the nut	Seal ring		Ordering number	
Standard nut	22 x 2		15844600	
3.1. Electrical connector EN 175301-803				
Type designation	Type	Maximum input voltage	Connector A grey	Connector B black
K5	without rectifier - M16x1.5 (bushing bore \varnothing 4-6 mm)	230 V DC	Ordering number	
			16202600	16202500
3.2. Electrical connector M23 - 7PIN (female)				
Ordering number		345579500001		
3.3. Electrical connector M12x1- 5PIN (male), it presented only for E03 and E04S01 configurations				
Ordering number		358359000002		
3.4. Electrical connector G4W1F				
Ordering number		358358932157		
3.5. Cover of connector M12x1				
Ordering number		23090600		
4. Seal kit				
Type	Dimensions, number		Order number	
Standard - NBR70	Square ring		O-ring	
	9.25 x 1.68 (4 pcs.)	17 x 1.8 (2 pcs.)		15845200
Viton	9.25 x 1.78 (4 pcs.)	17.17 x 1.78 (2 pcs.)		15845400
5. O-ring				
Standard - NBR70	32 x 2 (1 pc.)		273111014140	
6. Mounting bolts				
Dimensions, number		Tightening torque	Ordering number	
M5 x 45 DIN 912-10.9 (4 pcs.)		8.9 Nm (6.6 ft-lbs)	15845100	

Caution!

- The packing foil is recyclable. The protective plate can be returned to manufacturer
- The technical information regarding the product presented in this catalogue is for descriptive purposes only. It should not be construed in any case as a guaranteed representation of the product properties in the sense of the law.

ARGO-HYTOS s.r.o. CZ - 543 15 Vrchlaví
 Tel.: +420-499-403 111
 E-mail: info.cz@argo-hytos.com
 www.argo-hytos.com

6

- Digital control
- Compact design
- Operated by proportional solenoids
- High sensitivity and slight hysteresis
- Installation dimensions to DIN 24 340 / ISO 4401 / CETOP RP121-H

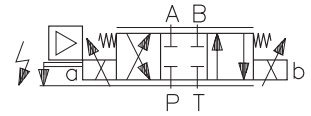
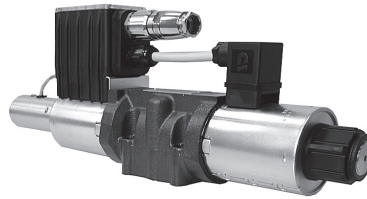

Functional Description

The proportional directional valve PRM7 consists of a cast iron housing, a special control spool, two centering springs with supporting washers, one or two proportional solenoids, a position sensor or, if need be, of a control box with digital electronics.

The measuring system of the position sensor consists of a differential transformer with core and from the evaluating electronic unit realized in hybrid technique.

With the model without integrated electronic unit, the electric connection of the solenoids is realized by the connector plug to EN 175301-803, with the position sensor output being connected by the G4W1F connector plug. Both connectors are supplied.

The proportional valve with the integrated electronic unit comprises an electronic control box that is mounted, together with the position sensor, on either of the solenoids. The connection of the position sensor with the control box is provided by a cable. With the model with two solenoids, the solenoid mounted opposite the control box is connected with the control box by means of a EN 175301-803, connector. The connection of the supply voltage, control signal, program input and external output of the position sensor is realized by a 5-pin connector (ELKA 5012). The connection of the external feedback is provided by a 5-pin connector, which also has three supply voltages +24 V, +10V and -5V for an external sensor available. The solenoid coils, including the control box, can be turned in a range of $\pm 90^\circ$. The digital control unit enables the proportional valve to be controlled on the basis of data required from two feedback circuits.

In this case the proportional valve can be used as follows:

1. Proportional directional valve
2. Only with the internal feedback from the spool position sensor.
3. Only with the external feedback (pressure sensor, position sensor, etc.).
4. With internal and external feedback.

The outlet current to the electromagnet coils is controlled with the help of PWM. The electronic system is equipped with an internal current feedback. The outlet current in case of need may be modulated with the use of a signal of dynamic lubrication. Single function parameters are set up with the use of appropriate software with the help of a computer connected to the proportional switchboard through a serial interface RS 232.

It is necessary to order a cable in accordance with appropriate ordering number as mentioned on page 4.

The digital control unit utilizes the pulse-with-modulation (PWM) and supplies the solenoids with current proportional to the control signal. The supply current is additionally modulated with a dither frequency. The individual functional parameters are adjusted through software by means of a special programmer, or by means of a computer through the RS 232 interface. The correct function of the digital control unit is signaled by a green LED. The incorrect function (failure) is indicated by a red LED.

As a standard, the proportional valve is delivered with factory setting. The model including also an external feedback shall be consulted with the manufacturer.

With the basic surface treatment, the valve housing is phosphate coated, whereas the surfaces of the solenoids are zinc coated.

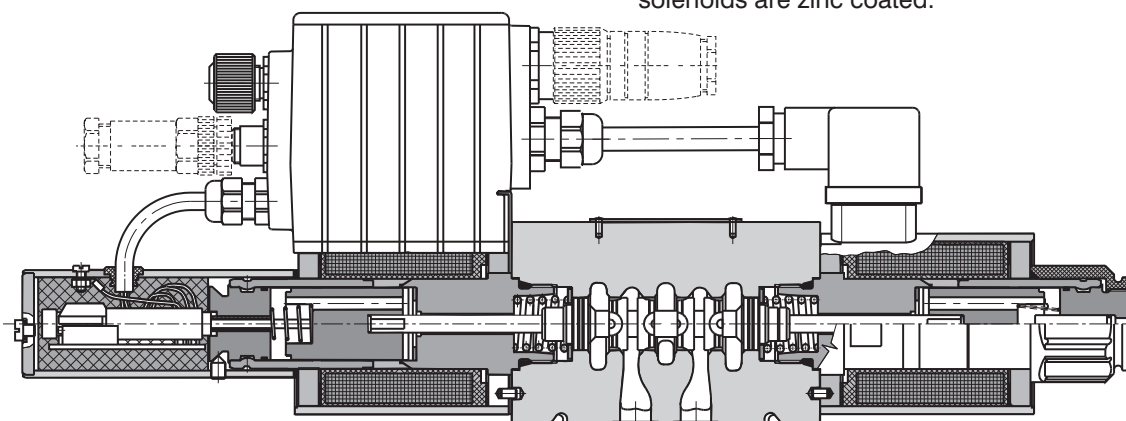

Ordering Code

PRM7-10 / -

Proportional Directional Control Valve

Seals

without designation
V

NBR
FPM (Viton)

Nominal size 10 (D 05)

Spool Symbols

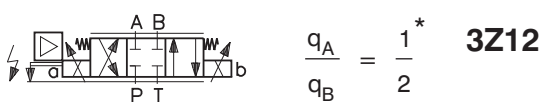

$$\frac{q_A}{q_B} = \frac{1}{2}^*$$

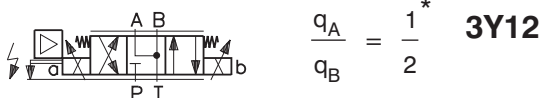

$$\frac{q_A}{q_B} = \frac{1}{2}^*$$

- Model**
- S01** position sensor with voltage outlet
 - S02** position sensor with current outlet
 - E01** proportional directional valve without feedback
 - E02S01** proportional directional valve with position feedback
 - E03** proportional directional valve with external feedback
 - E04S01** proportional directional valve with position and external feedback

Nominal solenoid supply voltage

12 **supply voltage 12V DC
24 supply voltage 24V DC

** Cannot be supplied as Variant S02

Spool Symbols Nominal flow rate at Δp = 10 bar (145 PSI)

30 flow 30 L/min (7.925 GPM)
60 flow 60 L/min (15.850 GPM)

* Model for cylinders with asymmetric piston rod, piston area ratio 1:2

Connectors are to be ordered **separately**, see ordering number on page 10

Technical Data		
Nominal size	mm (US)	10 (D 05)
Max. operating pressure at ports P, A, B	bar (PSI)	350 (5076)
Max. operating pressure at port T	bar (PSI)	210 (3046)
Hydraulic fluid		Hydraulic oils of power classes (HL, HLP) to DIN 51524
Fluid temperature range (NBR / Viton)	°C (°F)	-30 ... +80 (-22 ... +176) / -20 ... +80 (-4 ... +176)
Ambient temperature max.	°C (°F)	+50 (+122)
Viscosity range	mm ² /s (SUS)	20 ... 400 (98 ... 1840)
Maximum degree of fluid contamination		Class 21/18/15 to ISO 4406)
Nominal flow at $\Delta p = 10$ bar (145 PSI)	L/min (GPM)	30 (7.93) / 60 (15.85)
Hysteresis - open loop	%	< 6
Hysteresis - closed position loop	%	< 0.5
Weight - PRM7-102 - PRM7-103	kg (lbs)	4.4 (9.70) 5.9 (13.01)
Mounting position		unrestricted
Enclosure type EN 60529		IP65

Technical Data of Position Sensor - Voltage Outlet

Operating pressure	bar (PSI)	max. 350 (5076), static
Electric connection		electrical connector G4W1F Hirschmann *
Contact assignment		1 - Power supply 2 - Command signal 3 - GND 4 - not used
Enclosure type to EN 60529		IP65
Measured distance	mm (in)	8 (0.315)
Operating voltage	V	9.6 ...30 DC
Linearity error	%	< 1
Current consumption at load current of 2 mA	mA	< 15
Output voltage	V	0 ... 5
Output signal range used: 0 Position		2.5
1 solenoid - stroke 3.8 mm (0.15 in)	2	0.125 - 2.5
solenoids - stroke ± 3.8 mm (0.15 in)		0.125 - 4.875
Max. load current	mA	2
Noise voltage - at load current 0 - at load current of 2 mA	mV _{p-p}	< 20 < 15
Additional output signal error at: Temperature change between 0 ... 80 °C (32 ...176 °F) Between 0 ... -25 °C (32 ... -13 °F)		typical < 0.2% / 10K max. 0.5% / 10K max. 0.5% / 10K
Load change from 0 to 2 mA		0.1%
Input voltage change from 9.6 V to 14.4 V from 14.4 V to 30 V	%	< 0.1 < 0.25
Long-term drift (30 days)	%	< 0.25
Cut-off frequency 3 dB fall in amplitude Frequency 90°	Hz	> 600 > 600

* Only for S01 and S02 model.

Technical Data of Position Sensor - Current Outlet

Linearity	%	< 1
Operating pressure	bar (PSI)	to 350 (5076), static
Electrical connection		electrical connector G4W1F Hirschmann *
Contact assignment		1 - Power supply 2 - Command signal 3 - GND 4 - not used
Enclosure type to EN 60529		IP65
Operatin voltage	V	20 ... 30 DC
Current	mA	< 35
Output signal range	mA	4 20
Output signal range used: 0 position 1 solenoid - stroke 3.8 mm (0.15 in) 2 solenoids - stroke \pm 3.8 mm (0.15 in)	mA	12 4.4 ... 12 4.4 ... 19.6
Additional output signal error: - at temperature change from +10 ... 55 °C (50 ...131 °F) - at impedance change from 50% - at input voltage change in the range of operating voltage		0.2% / 10K \leq 0.1% \leq 0.05%
Impedance	Ω	\leq 500
Output signal ripple	mA R.M.S.	\leq 0.02
Limit frequency at 3 dB amplitude decrease	Hz	\geq 800

* Only for S01 and S02 model.

Technical Data of Proportional Solenoid

Type of coil	V	12 DC	24 DC
Limiting current	A	1.9	1.1
Resistance at 20 °C	Ω	4.7	13.9

Electronics Data

Supply voltage with polarity inversion protection	V	11.2 ... 28 VDC (residual ripple < 10%)
Input: command signal / according to customer setting		\pm 10V, 0 ... 10V, \pm 10mA, 4...20mA, 0...20mA, 12mA \pm 8mA
Input: spool position sensor signal		0...5V
Input: external feedback signal		0...10V, 4...20mA, 0...20mA,
Resolution of the A/D converter		12 bit
Output: solenoids		Two PWM output stages up to max. 3.5 A
PWM frequency	kHz	18
Adjustment of parameters	μ s	170
EMC	Interference resistance	61000 - 6 - 2 : 2005
	Radiation resistance	55011 : 1998 class A
Parameter setting	Serial port RS 232 (zero modem). 19200 bauds, 8 data bits, 1 stop bit, no parity. Special software PRM7Conf.	

Accessories

Order number	Content
23093400	Connecting cable to PC - length 2m (6.56ft), CD-ROM with program PRM7Conf and user manual.
23093500	Connecting cable to PC - length 5m (16.40ft), CD-ROM with program PRM7Conf and user manual.
24523400	Connecting cable to PC - length size 2m (6.56ft).
24523500	Connecting cable to PC - length size 5m (16.40ft).

Limit Power

Measured at $v = 32 \text{ mm}^2/\text{s}$ (156 SUS)

Only for E01 model

Nominal flow 30 L/min (7.93 GPM)

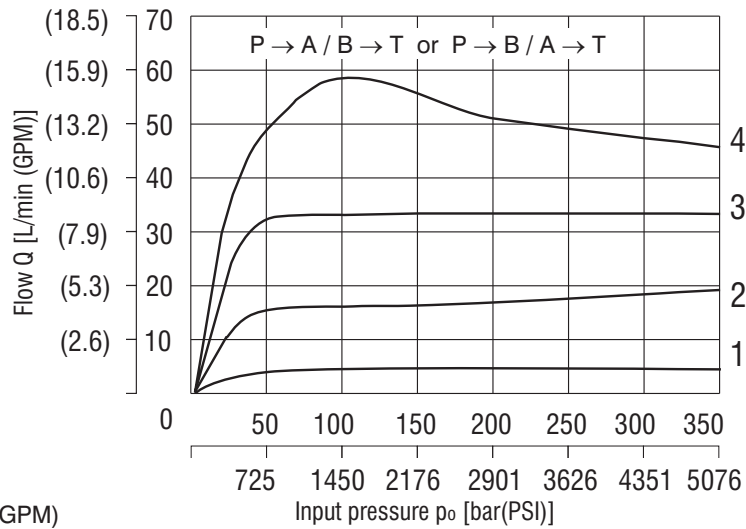

Nominal flow 60 L/min (15.85 GPM)

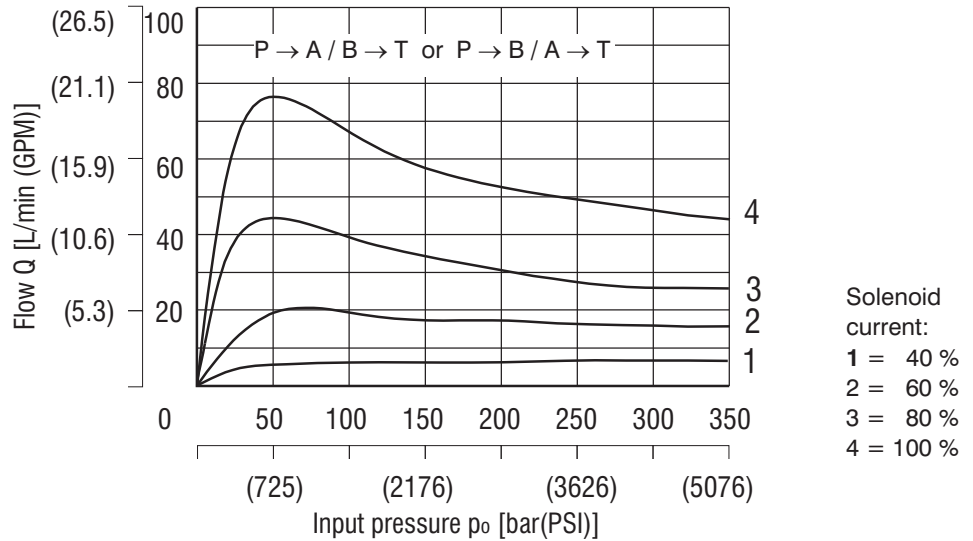

Flow Characteristics

Measured at input pressure $\Delta p = 10 \text{ bar}$ (145 PSI), $v = 32 \text{ mm}^2/\text{s}$ (156 SUS)

Only for E01 model

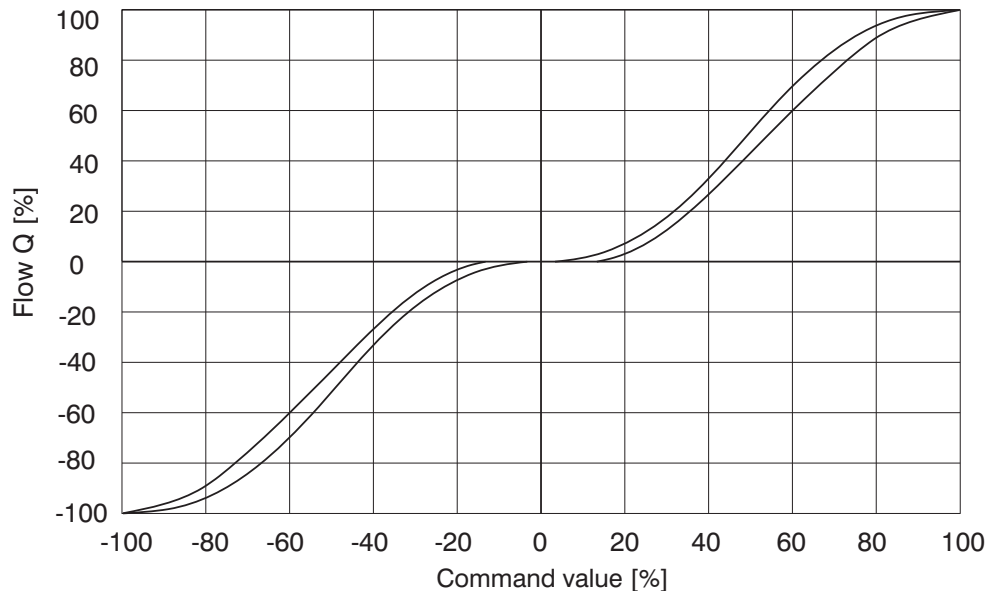

6

Flow Characteristics

Measured at $v = 32 \text{ mm}^2/\text{s}$ (156 SUS)

Only for E02S01 model

$Q_n = 30 \text{ L/min}$ (7.93 GPM) by $\Delta p = 10 \text{ bar}$ (145 PSI)

Δp = Valve pressure differential
(inlet pressure p_V minus load pressure and return pressure p_T)

Δp_n = Valve pressure differential for nominal flow Q_n

1	$\Delta p_n = 10 \text{ bar}$ (145 PSI)
2	$\Delta p = 50 \text{ bar}$ (725 PSI)
3	$\Delta p = 160 \text{ bar}$ (2321 PSI)
4	$\Delta p = 320 \text{ bar}$ (4641 PSI)

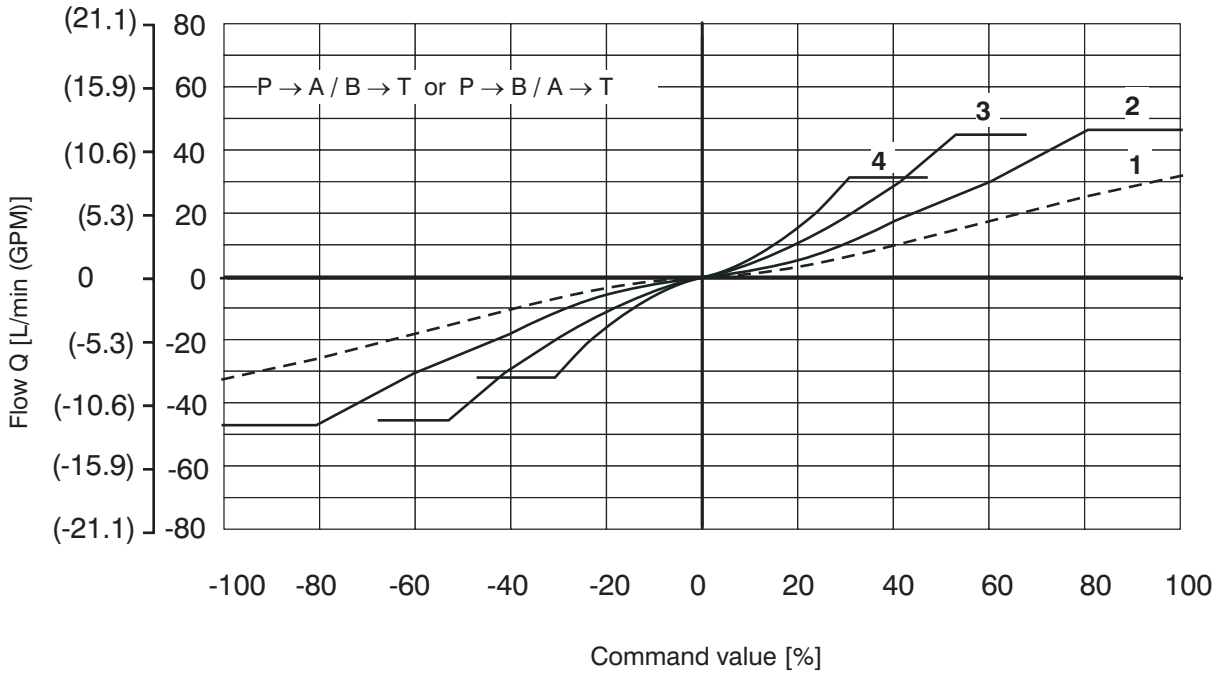

Only for E02S01 model

$Q_n = 60 \text{ L/min}$ (15.85 GPM) by $\Delta p = 10 \text{ bar}$ (145 PSI)

1	$\Delta p_n = 10 \text{ bar}$ (145 PSI)
2	$\Delta p = 50 \text{ bar}$ (725 PSI)
3	$\Delta p = 160 \text{ bar}$ (2321 PSI)
4	$\Delta p = 320 \text{ bar}$ (4641 PSI)

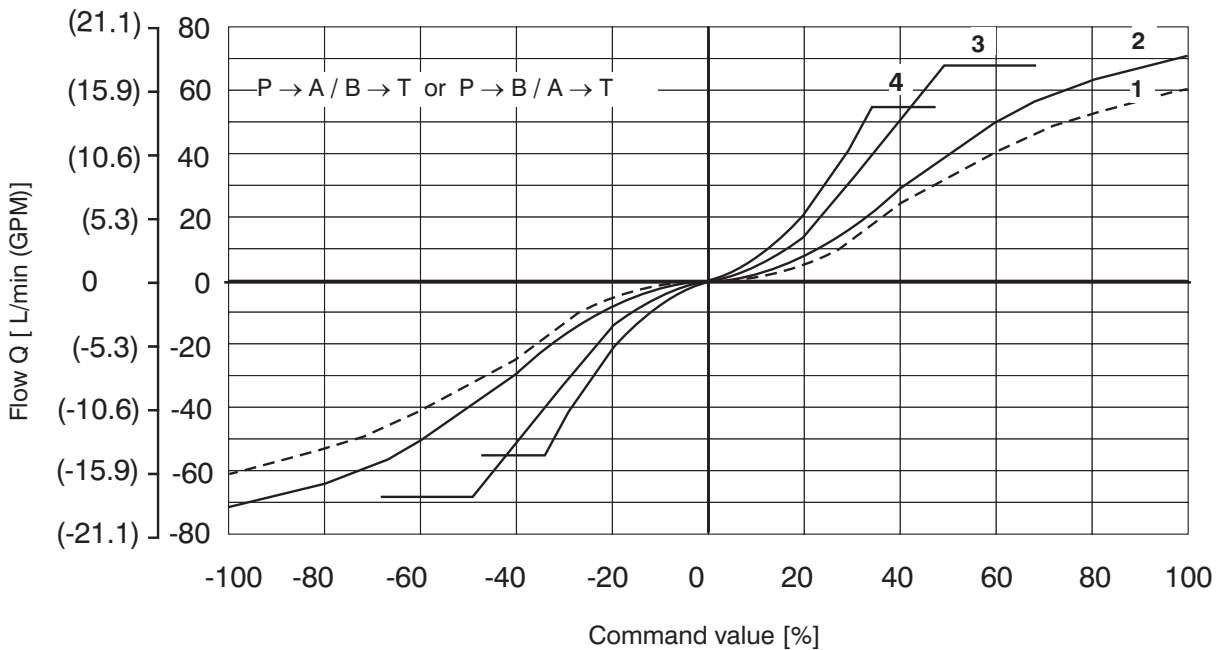

Frequency Reponse

closed position loop. for E02S01 model

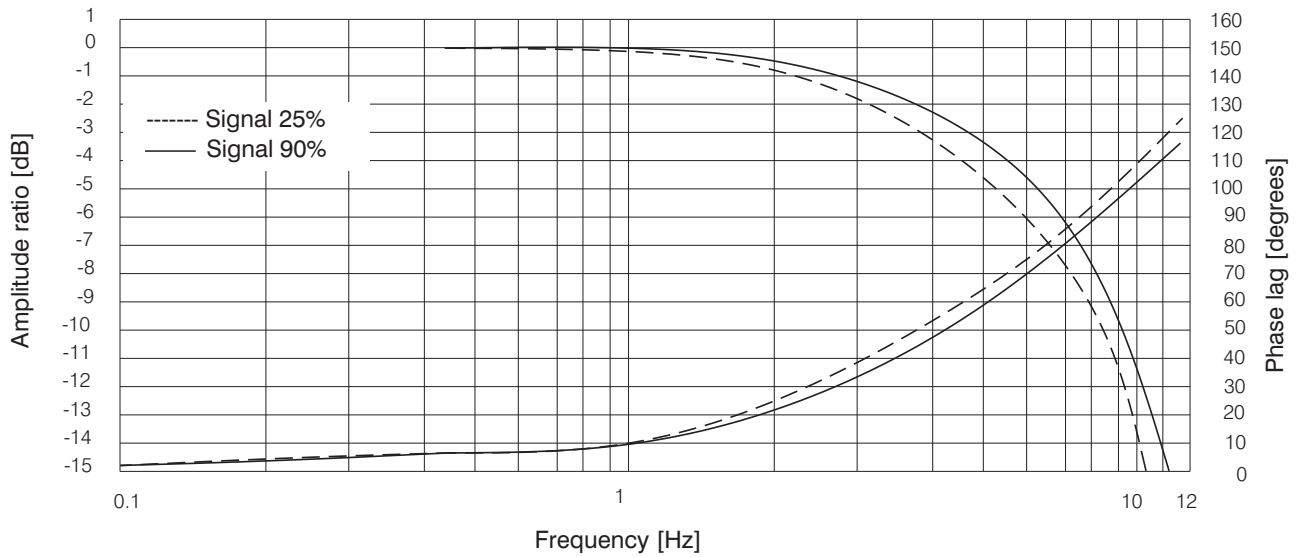

Connector Connection

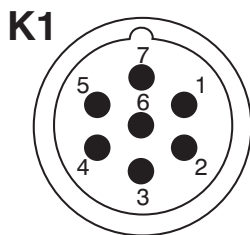

Connector K1- type M 23 (male)		
PIN	Technical data	Description
1	* Power supply input	11.2 28V DC
2	* Ground (power supply)	0V
3	Control signal	according to configuration
4	Ground (signal)	0V
5	Power reference signal	+10V DC/max.10mA
6	Control signal of position sensor spool	05V
7	* Protection earth lead (PE)	---

* Recommended min. lead cross section 0.75mm²

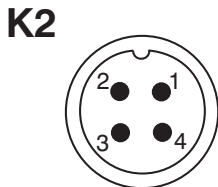

Connector K2 - type M12x1 (male)		
PIN	Technical data	Description
1	TxD	standard
2	RxD	RS 232
3	Ground (signal)	0V
4	Not used	

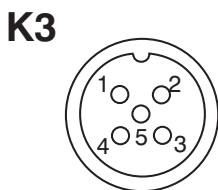

Connector K3 - type M12x1 (female)		
PIN	Technical data	Description
1	Power supply output	11.2 28V DC/max.100mA
2	Signal of external feedback	according to configuration
3	Ground	0V
4	Not used	
5	Not used	

K2 - Connection RS232 M12x1 (4 PIN)
For programming the electronics.

K1 - Main input connector M23 (7PIN)
Cable diameter 8 ...12mm.

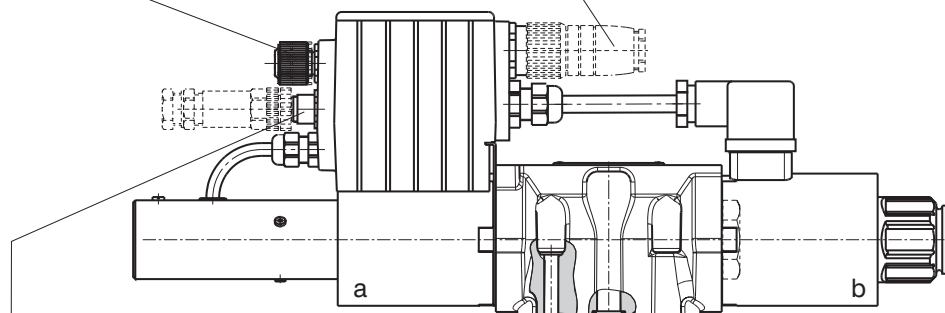

K3 - Conektor M12x1 (5PIN)
External feedback signal (it presented only for E03 and E04S01 configurations).

6

Factory Settings

Item	Model							
	E01		E02S01		E03		E04S01	
	1 Magnet	2 Magnet	1 Magnet	2 Magnet	1 Magnet	2 Magnet	1 Magnet	2 Magnet
Control signal	0...10 V	± 10 V	0...10 V	± 10 V	0...10 V	± 10 V	0...10 V	± 10 V
Signal external feedback	-	-	-	-	0...10 V			
Output position sensor spool	-	-	0...5 V		-		0...5 V	

Valve Dimensions

Dimensions in millimeters (inches)

102, 103 ... S01

102, 103 ... S02

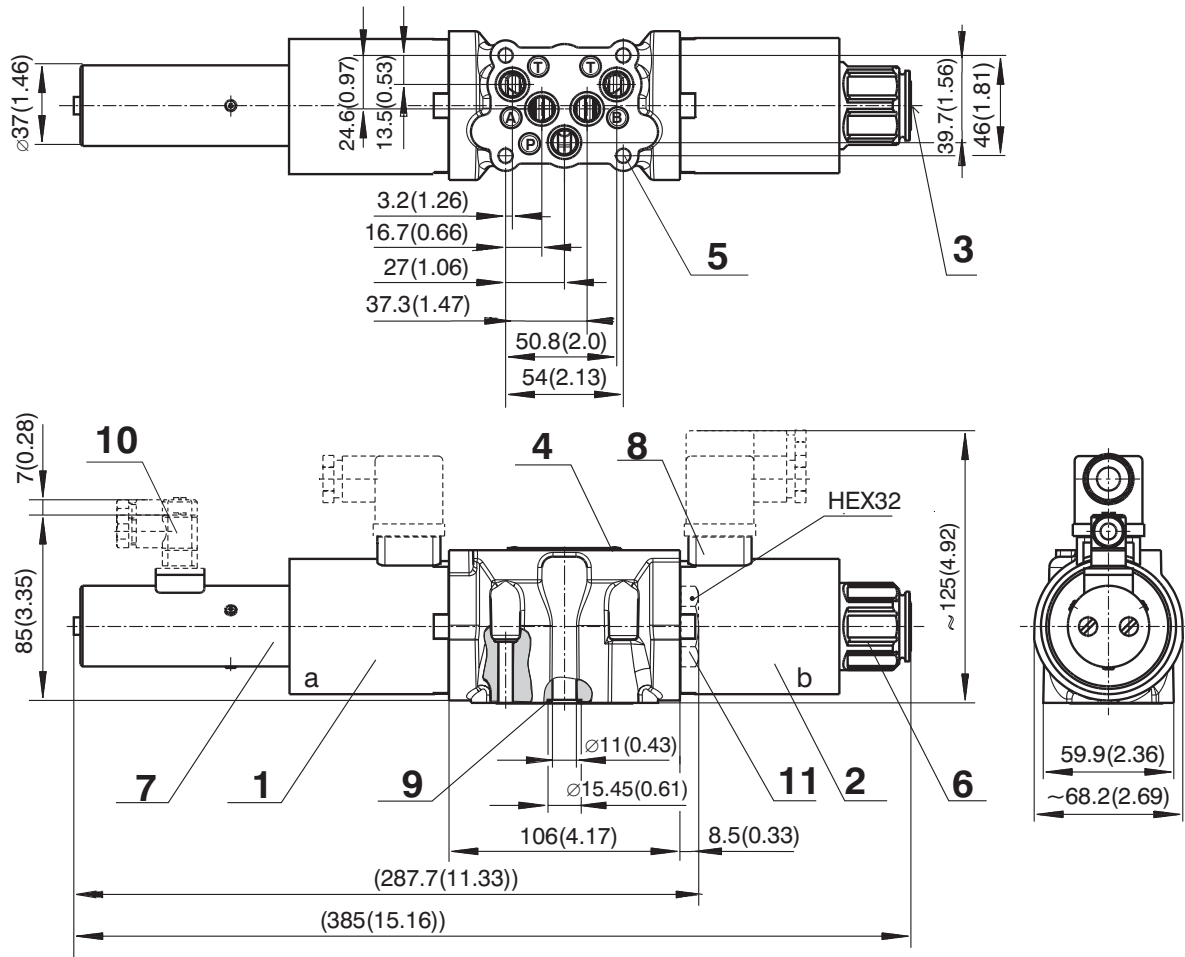

- 1 Solenoid a
- 2 Solenoid b
- 3 Manual overrid
- 4 Name plate
- 5 4 mounting holes
- 6 Solenoid fixing nut
- 7 Position sensor
- 8 Solenoid supply connector
- 9 Square ring 12.42 x 1.68 (5 pcs.), supplied in delivery packet
- 10 Position sensor connector
- 11 Plug screw for valve with one solenoid, HEX 32, configurations 2Z51, 2Z11

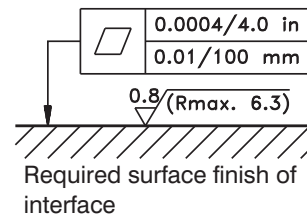

Valve Dimensions

Dimensions in millimeters (inches)

102, 103 ... E01 - without connector plug for spool position feedback

102, 103 ... E03

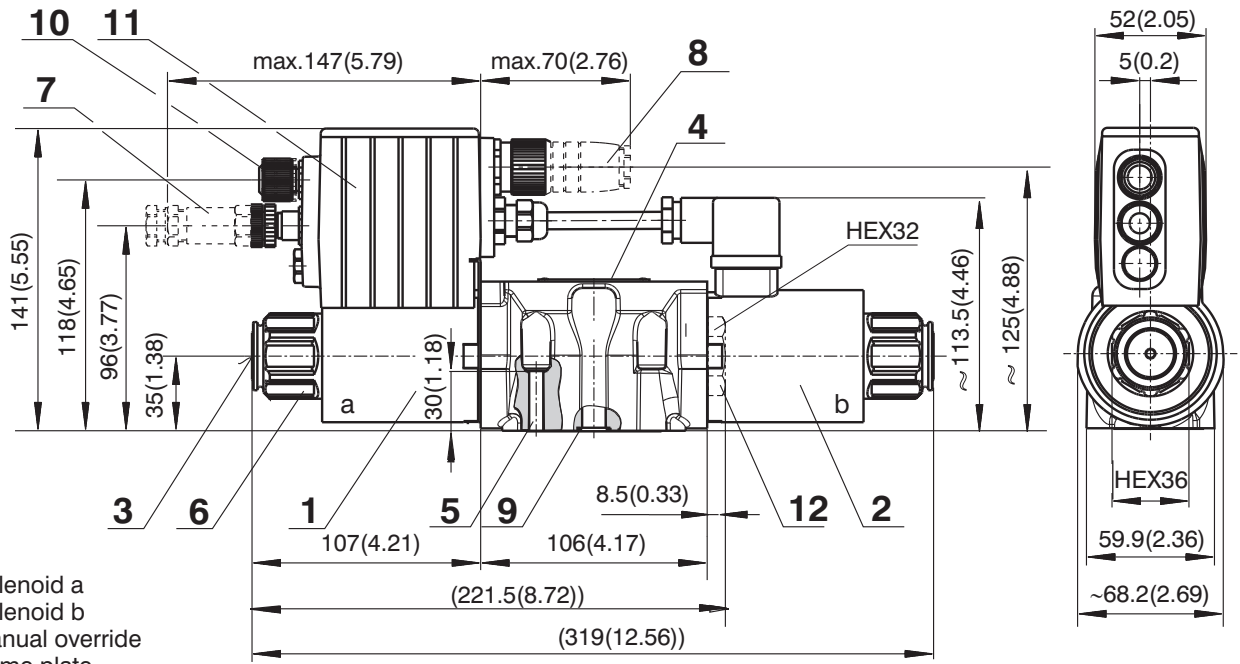

- 1 Solenoid a
- 2 Solenoid b
- 3 Manual override
- 4 Name plate
- 5 4 mounting holes
- 6 Solenoid fixing nut
- 7 Connector M12x1 for connection of external feedback
- 8 Main supply connector M23
- 9 Square ring 12.42 x 1.68 (5 pcs.), supplied in delivery packet
- 10 Cover of connector M12x1 for programming
- 11 Plastic box with integrated electronics
- 12 Plug screw for valve with one solenoid, HEX 32, configurations 2Z51, 2Z11

102, 103 ... E02S01 - without connector plug for spool position feedback

102, 103 ... E04S01

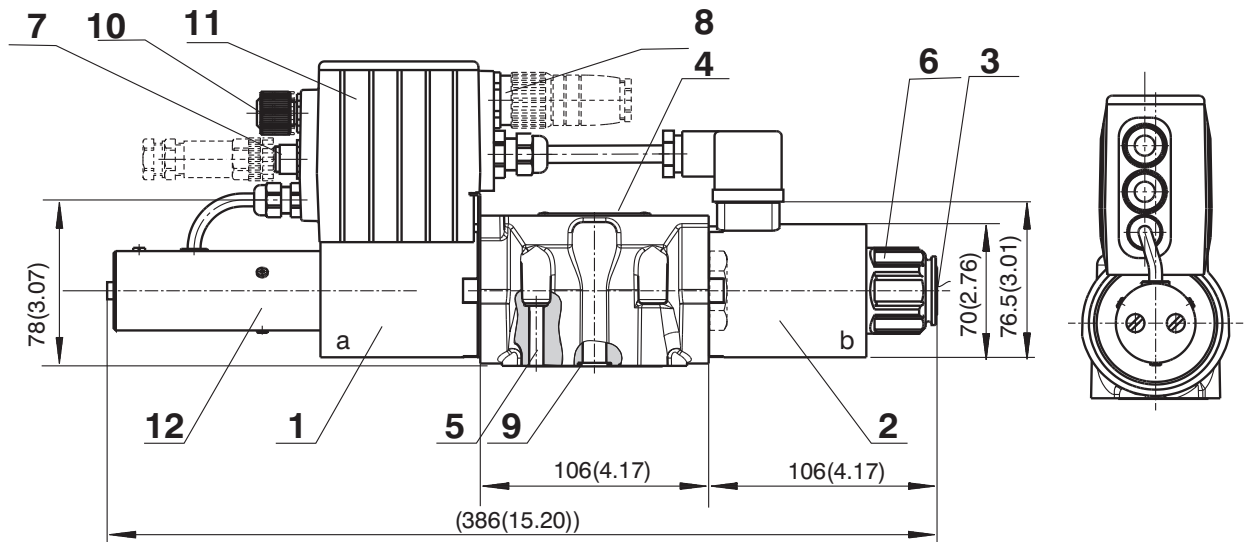

- 1 Solenoid a
- 2 Solenoid b
- 3 Manual override
- 4 Name plate
- 5 4 mounting holes
- 6 Solenoid fixing nut
- 7 Connector M12x1 for connection of external feedback
- 8 Main supply connector M23
- 9 Square ring 12.42 x 1.68 (5 pcs.), supplied in delivery packet
- 10 Cover of connector M12x1 for programming
- 11 Plastic box with integrated electronics
- 12 Position sensor

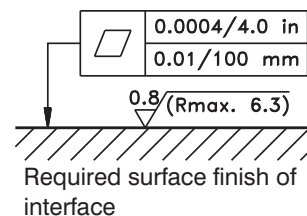

6

Spare Parts

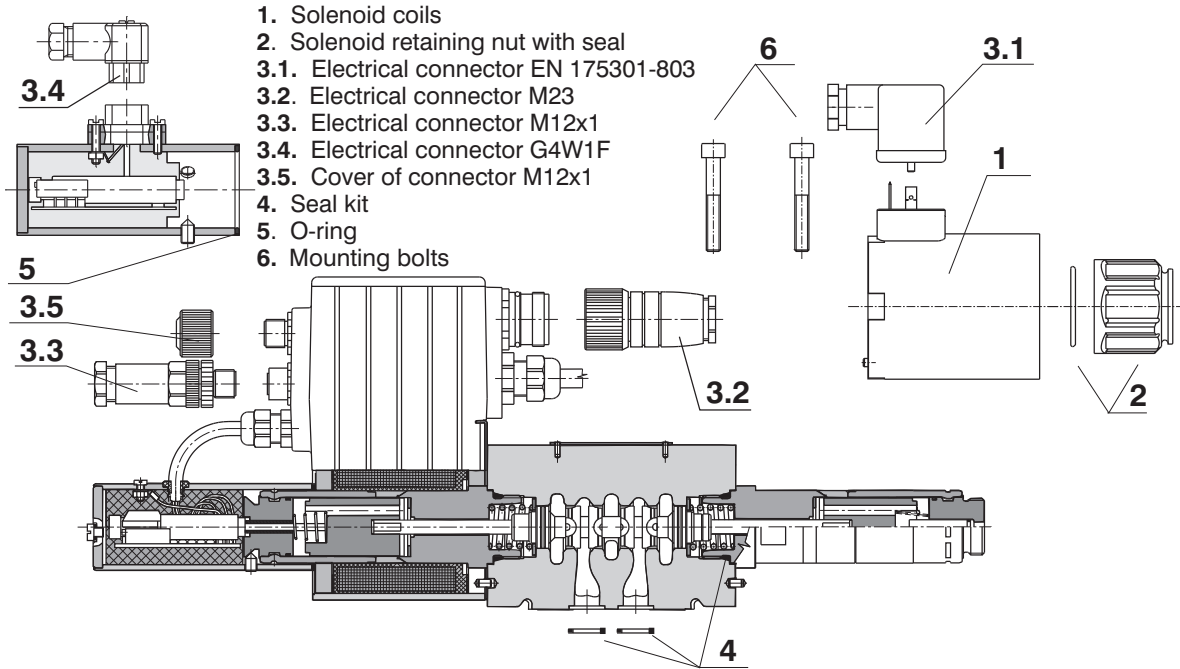

1. Solenoid coil

Solenoid type	Ordering number
01200	16195800
02400	16196200

2. Solenoid retaining nut with seal

Type of the nut	Seal ring	Ordering number
Standard nut	30 x 2	15900800

3.1. Electrical connector EN 175301-803

Type designation	Type	Maximum input voltage	Connector A	Connector B
			grey	black
			Ordering number	
K5	without rectifier - M16x1.5 (bushing bore \varnothing 4-6 mm)	230 V DC	16202600	16202500

3.2. Electrical connector M23 - 7PIN (female)

Ordering number	345579500001
-----------------	--------------

3.3. Electrical connector M12x1- 5PIN (male), it presented only for E03 and E04S01 configurations

Ordering number	358359000002
-----------------	--------------

3.4. Electrical connector G4W1F

Ordering number	358358932157
-----------------	--------------

3.5. Cover of connector M12x1

Ordering number	23090600
-----------------	----------

4. Seal kit

Type	Dimensions, number		Order number
	Square ring	O-ring	
Standard - NBR70	12.42 x 1.68 (5 pcs.)	23.81 x 2.62 (2 pcs.)	23114300
Viton	12.42 x 1.68 (5 pcs.)	23.47 x 2.62 (2 pcs.)	23114400

5. O-ring

Standard - NBR70	32 x 2 (1 pc.)	273111014140
------------------	----------------	--------------

6. Mounting bolts

Dimensions, number	Tightening torque	Ordering number
M6 x 40 DIN 912-10.9 (4 pcs.)	14 Nm (10.33 lbf.ft)	15847700

Caution!

- The packing foil is recyclable. The protective plate can be returned to manufacturer.
- The technical information regarding the product presented in this catalogue is for descriptive purposes only. It should not be construed in any case as a guaranteed representation of the product properties in the sense of the law.

ARGO-HYTOS s.r.o. CZ - 543 15 Vrchlaví
 Tel.: +420-499-403 111
 E-mail: info.cz@argo-hytos.com
 www.argo-hytos.com

- Screw-in cartridge design
- Direct acting, poppet type
- Three pressure ranges
- Pressure output proportional to DC current input

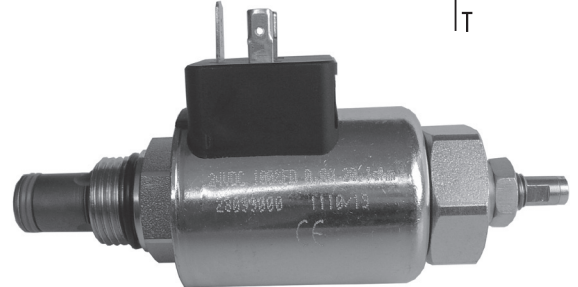
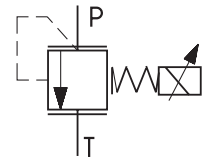

Functional Description

The valve is designed for continuous regulation of pressure in the circuit. The valve consists of the seat (1), poppet (3), return spring (2), main spring (4), spring supporting ring (5) and control proportional solenoid (6).

In the basic position (with the coil deenergized) the port P is fully open to port T. Proportional increase of DC current at solenoid (6) increase force to valve poppet (3) through preload spring (4).

This blocks flow in direction P – T until sufficient pressure is pre-sent to offset electrically induced solenoid force.

The minimum value of the cracking pressure can be adjusted using the screw (7), position of which is secured with the nut (8). The adjusting screw (7) can also be used as the emergency control. Screw (9)

is used to air bleed the solenoid control system. To ensure self-bleeding of the valve it is recommended to install it in a vertical position with the solenoid facing downwards. Bleeding process is necessary for the proper functioning of the valve.

The valve can be used alone or as a built-in, pilot operated pressure relief valve SR4P2-B2 (datasheet No. HC 5117), or as a control valve of a built-in indirectly controlled pilot operated pressure reducing valve SP4P2-B3 (datasheet No. HA 5123).

The valve body and the adjustment screw are zinc coated.

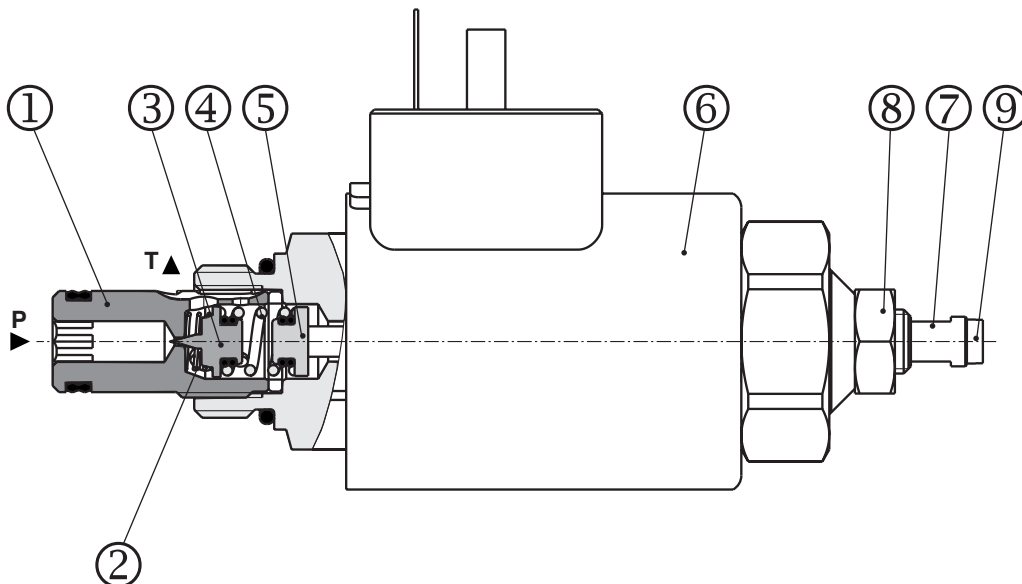

6

Ordering Code

SR1P2-A2 / -

Proportional Directly Operated
Pressure Relief Valve 3/4-16UNF

High performance

H

Pressure range

up to 120 bar (1740 PSI)
up to 210 bar (3046 PSI)
up to 350 bar (5076 PSI)

12
21
35

Nominal solenoid supply voltage

12 V DC
24 V DC

12
24

V

Seals

Viton (FPM)

Type of solenoid coil

E2

Connector EN 175301-803-A
with quenching diode

E4

Connector AMP Junior Timer with
quenching diode

E13

Connector Deutsch DT04-2P with
quenching diode

Other coils on demand see catalog HA8007.

Technical Data

Valve size		A2
Cartridge Cavity		3/4-16 UNF-2A
Maximum operating pressure at ports P	bar (PSI)	350 (5076)
Maximum operating pressure at ports T*	bar (PSI)	100 (1450)
Flow range	L/min (GPM)	1,5 (0.396)
Hydraulic fluid		Hydraulic oils of power classes (HL, HLP) to DIN 51524
Fluid temperature range (FPM)	°C (°F)	-20 ...120 (-4 ... 248)
Ambient temperature, range	°C (°F)	-20 ... 80 (-4 ...176)
Viscosity range	mm ² /s (SUS)	10 ... 500 (49 ... 2450)
Duty cycle	%	100
Enclosure type to EN 60 529		IP 67 (IP 65)
Maximum valve tightening torque	Nm (lbf.ft)	30+2 (22.12+1.47)
Optimum dither control	Hz	200
Maximum degree of fluid contamination		Class 21/18/15 according to ISO 4406
Minimum reachable pressure for Q=1,5 L/min (0.396 GPM)	bar (PSI)	~ 20 (290)
Valve hysteresis	%	< 5
Weight	kg (lb)	0,440 (0.97)
Mounting position		When possible, the valve should be mounted with solenoid faced down.
Valve body (data shee HA 0018)		SB-A2

*Pressure in T influences $p = f(l)$ a $p = f(Q)$ valve performance

Solenoid Technical Data

Type of coil	V	12 DC	24 DC
Limit current	A	1	0,6
Resistance at 20 °C (68 °F)	Ω	6,5	20,8
Quenching diode (E2, E4, E13)		BZW06-19B	BZW06-33B

p-I Characteristics

Measured at $v = 32 \text{ mm}^2/\text{s}$ (156 SUS)

$p = f(I), Q = 0,2 \text{ L/min}$ (0.053 GPM)

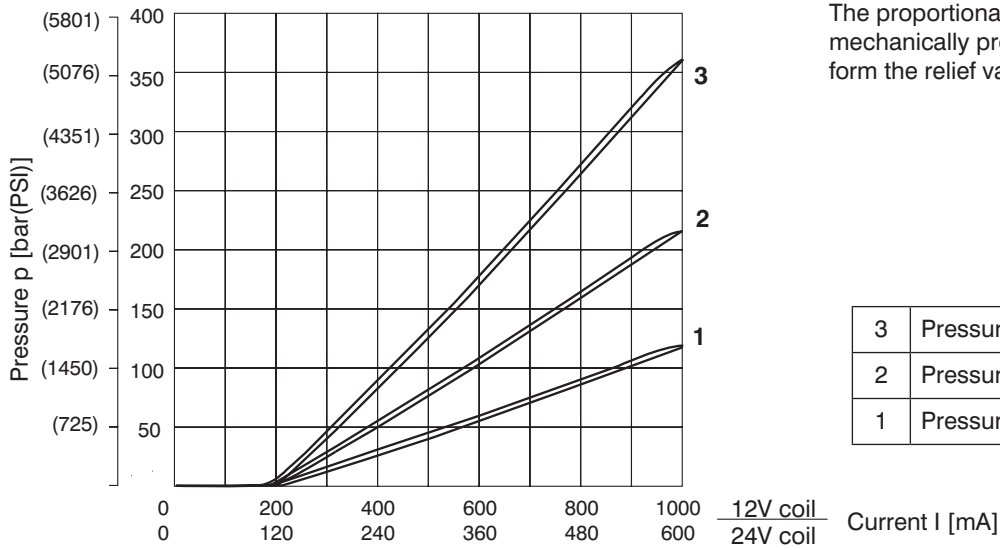

Attention:

The proportional pressure relief valve is not mechanically protected and it does not perform the relief valve function.

3	Pressure range 35
2	Pressure range 21
1	Pressure range 12

Type of the Solenoid Coil

Note:

Example of most frequent coil types.

For complete range valve coils with technical informatik about voltage, enclosure type, terminal box please refer to coil data sheet HA 8007.

Coil example	Solenoid	Connector	Type code
<p>Type E2</p>	12 VDC	Connector EN 175301-803-A with quenching diode	C19B-01200E2-6,5NA
	24 VDC	Connector EN 175301-803-A with quenching diode	C19B-02400E2-20,1NA
	12 VDC	Connector AMP Junior Timer with quenching diode	C19B-01200E4-6,5NA
	24 VDC	Connector AMP Junior Timer with quenching diode	C19B-02400E4-20,1NA
	12 VDC	Connector Deutsch DT04-2P with quenching diode	C19B-01200E13-6,5NA
	24 VDC	Connector Deutsch DT04-2P with quenching diode	C19B-02400E13-20,8NA

Valve Dimensions

Dimensions in millimeters and (inches)

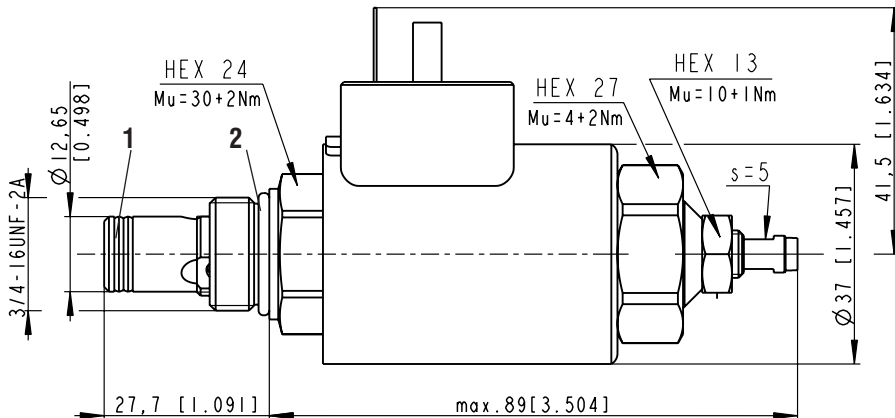

Seal kit

- see Spare Parts
- 1. Dualseal - PU
- 2. O-ring - Viton

HEX 24 $M_u = [30+2 \text{ Nm} (22+1.47 \text{ lb.ft})]$
 HEX 27 $M_u = [4+2 \text{ Nm} (2.95+1.47 \text{ lb.ft})]$
 HEX 13 $M_u = [10+1 \text{ Nm} (7.37+0.73 \text{ lb.ft})]$

Cavity

Dimensions in millimeters and (inches)

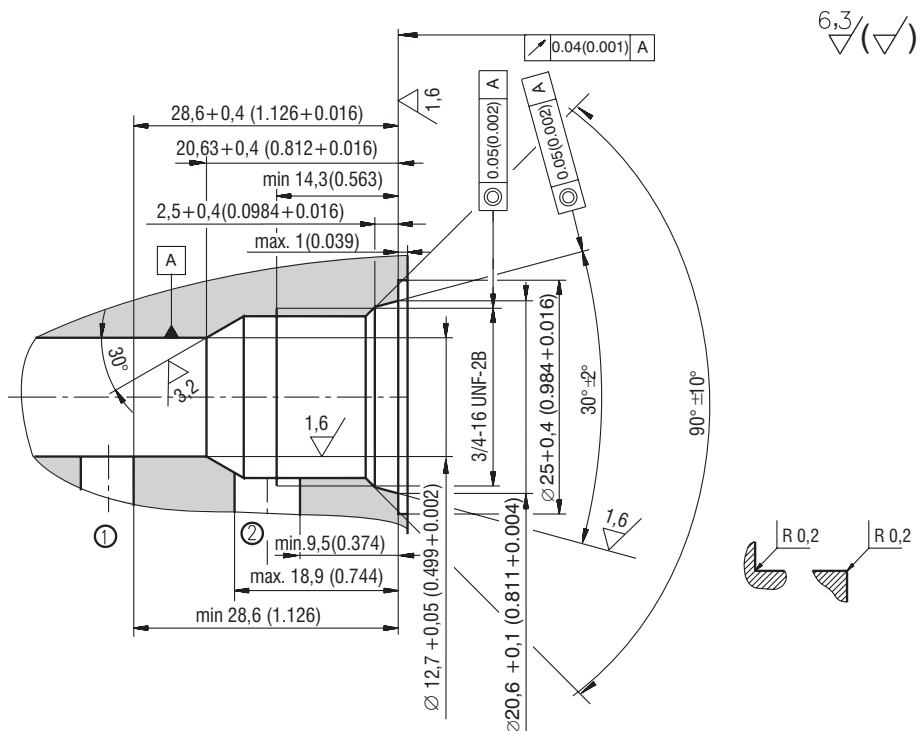

Spare Parts

Solenoid coil	Type of the coil		
	E2	E4	E13
Nominal voltage coil	Ordering number		
12 V DC	28145600	28145800	29867600
24 V DC	27824300	27824400	29868600
Seal kit	Dimensions, quantity		Ordering number
	Dualseal - PU	O-ring	
	10,3 x 12,7 x 3,1 (1pc)	17,17 x 1,78 (1pc)	17014300

Caution!

- The packing foil is recyclable.
- The technical information regarding the product presented in this catalogue is for descriptive purposes only. It should not be construed in any case as a guaranteed representation of the product properties in the sense of the law.

ARGO-HYTOS s.r.o. CZ - 543 15 Vrchlábí
 tel.: +420-499-403 111
 e-mail: info.cz@argo-hytos.com
 www.argo-hytos.com

- Screw-in cartridge design
- Pilot operated
- Three pressure ranges
- Pressure output proportional to DC current input

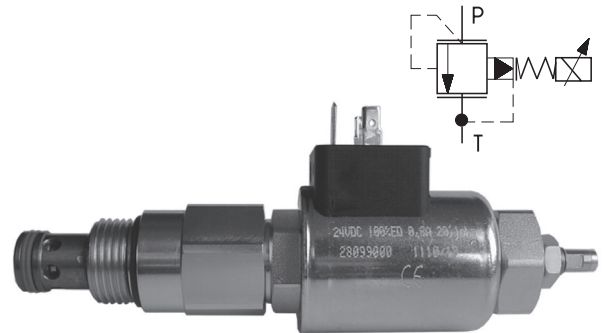

Functional Description

The valve is designed for continuous regulation of pressure in the circuit.

The valve is pilot operated using the pilot stage of SR1P2-A2 execution.

Due to two stage pilot design the valve is able to control high hydraulic power in circuit.

The complete valve consist of pilot stage valve SR1P2-A2 and main stage size 7/8-14 UNF.

In the basic position (with the coil de-energized) the port P is fully open to the tank.

Connection to the pilot stage is realized with nozzles (5) and (6) and the spring chamber (4) is unloaded to the tank port.

When the DC current is applied to solenoid (10) at spring (9) increases force to the seat (8) and it continuously closes.

Build up pressure acts on spool (3) in spring chamber (4) against the pressure line P thus closing the P line to the Tank port.

The valve opens when the increasing pressure on P line reaches value set by proportional solenoid (10).

In this situation the main spool (3) shift to open the Tank line against the spring (4).

Build up pressure P in system is proportional to the energizing current at solenoid (10).

The minimum value of cracking pressure can be adjusted using the screw (12), position of which is secured with nut (11). The adjusting screw (12) can be used as emergency control. Screw (13) is used to air bleed the solenoid control system. To ensure self bleeding of the valve it is recommended to install it in a vertical position with the solenoid facing downwards. Bleeding process is necessary for the proper function of the valve.

Pilot stage valve SR1P2-A2 (catalogue no. HA 5122) can be ordered separately as a built-in proportional directly operated pressure relief valve. The main stage of the valve can be also ordered separately – see spare parts.

The valve body and the adjustment screw are zinc coated.

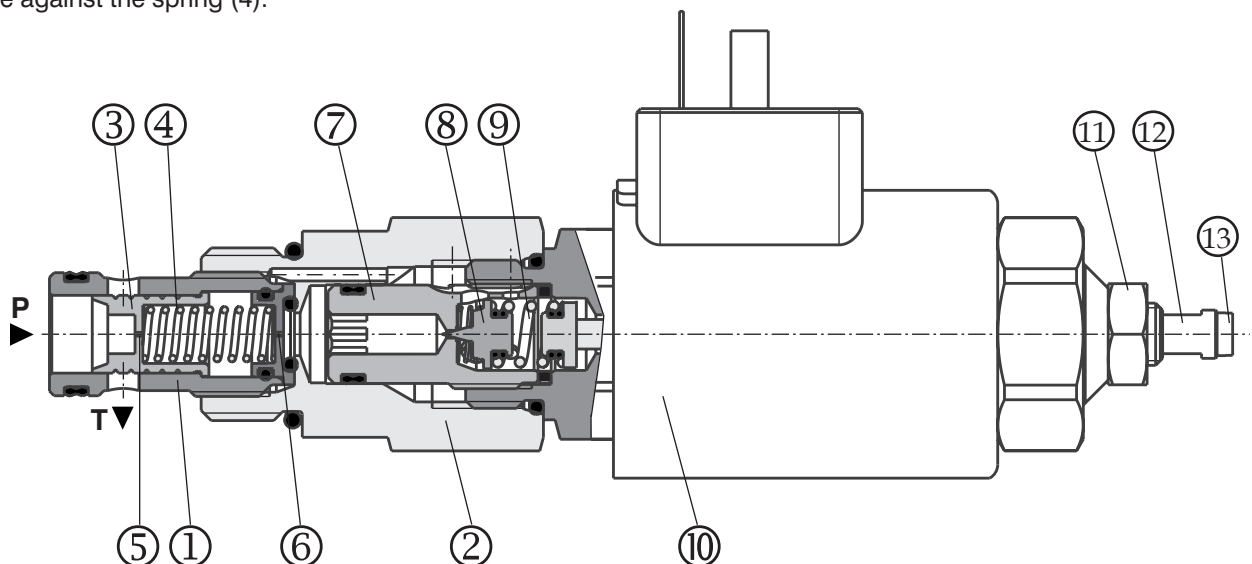

Ordering Code

SR4P2-B2 / -

Proportional Pilot Operated Pressure Relief Valves 7/8-14UNF

High performance

H

Pressure range

up to 120 bar (1740 PSI)
up to 210 bar (3046 PSI)
up to 350 bar (5076 PSI)

12
21
35

Nominal solenoid supply voltage

12 V DC
24 V DC

12
24

V

Seals

Viton (FPM)

Type of solenoid coil

E2

Connector EN 175301-803-A with quenching diode

E4

Connector AMP Junior Timer with quenching diode

E13

Connector Deutsch DT04-2P with quenching diode

Other coils on demand see catalog HA8007.

Technical Data

Valve size		B2
Cartridge Cavity		7/8-14UNF-2A
Maximum operating pressure at ports P	bar (PSI)	350 (5076)
Maximum operating pressure at ports T*	bar (PSI)	100 (1450)
Flow range	L/min (GPM)	0 ÷ 60 (0 ÷ 15.85)
Hydraulic fluid		Hydraulic oils of power classes (HL, HLP) to DIN 51524
Fluid temperature range (FPM)	°C (°F)	-20 ... 120 (-4 ... 248)
Ambient temperature range	°C (°F)	-20 ... 80 (-4 ... 176)
Viscosity range	mm ² /s (SUS)	10 ... 500 (49 ... 2450)
Duty cycle	%	100
Enclosure type to EN 60 529		IP67 (IP65)
Maximum valve tightening torque	Nm (lbf.ft)	50+5
Optimum dither control	Hz	250
Maximum degree of fluid contamination		Class 21/18/15 according to ISO 4406
Minimum reachable pressure for Q = 5 L/min (1.321 GPM)	bar (PSI)	~ 7 (101,5)
Valve hysteresis	%	< 5
Weight	kg (lb)	0,580 (1.278)
Mounting position		When possible, the valve should be mounted with solenoid faced down.
Valve body (data shee HA 0018)		SB-B2

*Pressure in T influences $p = f(I)$ a $p = f(Q)$ valve performance

Solenoid Technical Data

Type of coil	V	12 DC	24 DC
Limit current	A	1	0,6
Resistance at 20 °C (68 °F)	Ω	6,5	20,8
Quenching diode (E2, E4, E13)		BZW06-19B	BZW06-33B

Valve Dimensions

Dimensions in millimeters and (inches)

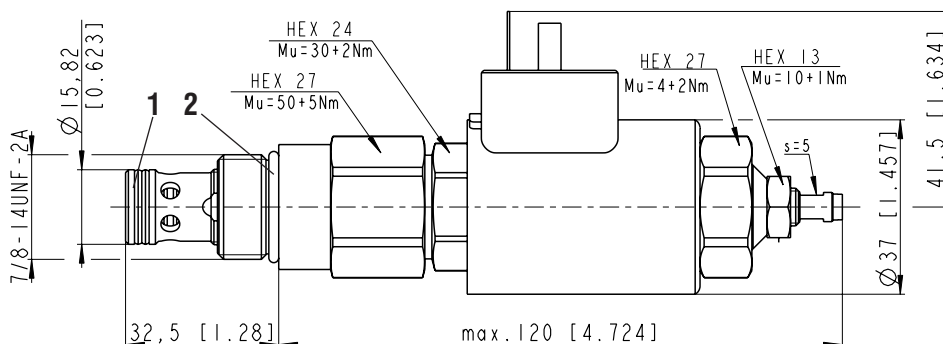

Seal kit (Main valve)

- see Spare Parts
- 1. Dualseal - PU
- 2. O-ring - Viton

$M_u = [50 + 5 Nm (37 + 3.38 lb.ft)]$
 $M_u = [30 + 2 Nm (22 + 1.47 lb.ft)]$
 $M_u = [4 + 2 Nm (2.95 + 1.47 lb.ft)]$
 $M_u = [10 + 1 Nm (7.37 + 0.73 lb.ft)]$

p-I Charakteristic

Measured at $v = 32 \text{ mm}^2/\text{s}$ (156 SUS)

$p = f(I), Q = 5 \text{ L/min}$ (1.321 GPM)

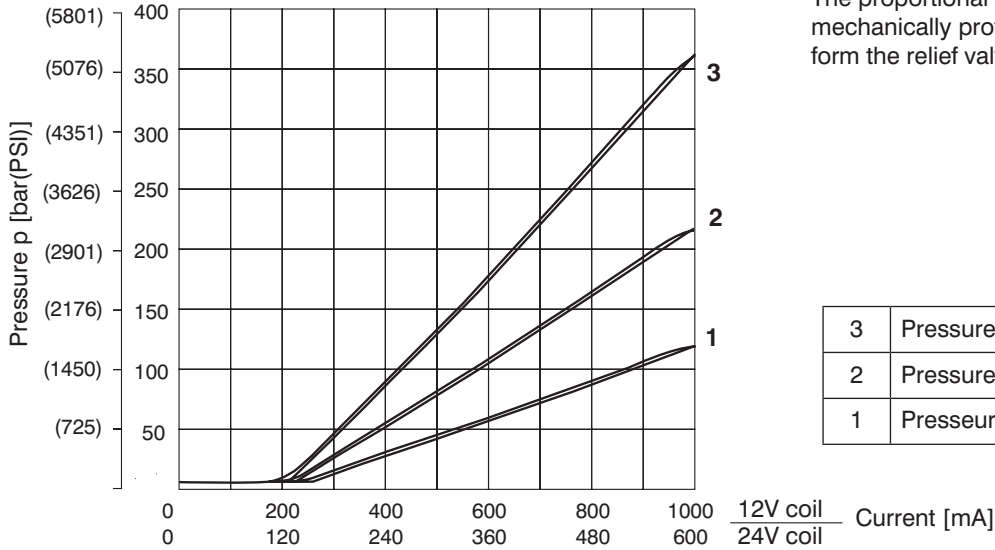

Attention:

The proportional pressure relief valve is not mechanically protected and it does not perform the relief valve function.

3	Pressure range 35
2	Pressure range 21
1	Pressure range 12

p-Q Charakteristic

Measured at $v = 32 \text{ mm}^2/\text{s}$ (156 SUS)

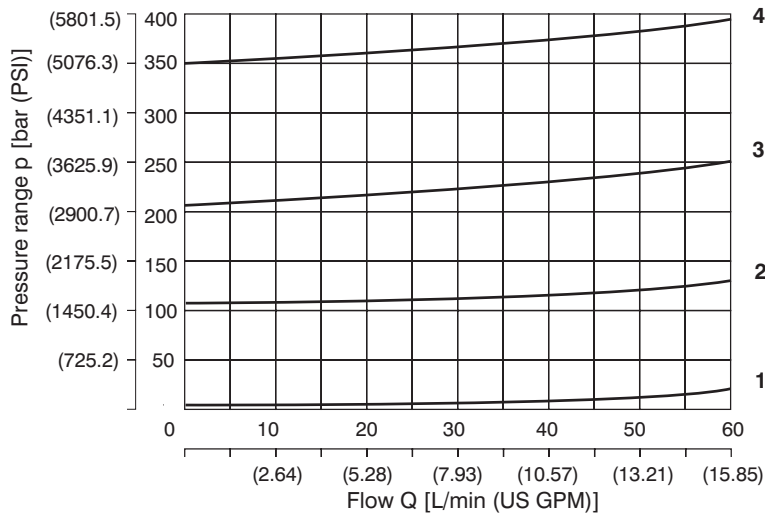

4	Pressure range 35
3	Pressure range 21
2	Pressure range 12
1	Min. pressure (range 35)

Type of the Solenoid Coil

Note:

Example of most frequent coil types.

For complete range valve coils with technical informatik about voltage, enclosure type, terminal box please refer to coil data sheet HA 8007.

Coil example	Solenoid	Connector	Type code
<p>Type E2</p>	12 VDC	Connector EN 175301-803-A with quenching diode	C19B-01200E2-6,5NA
	24 VDC	Connector EN 175301-803-A with quenching diode	C19B-02400E2-20,1NA
	12 VDC	Connector AMP Junior Timer with quenching diode	C19B-01200E4-6,5NA
	24 VDC	Connector AMP Junior Timer with quenching diode	C19B-02400E4-20,1NA
	12 VDC	Connector Deutsch DT04-2P with quenching diode	C19B-01200E13-6,5NA
	24 VDC	Connector Deutsch DT04-2P with quenching diode	C19B-02400E13-20,8NA

Cavity

Dimensions in millimeters and (inches)

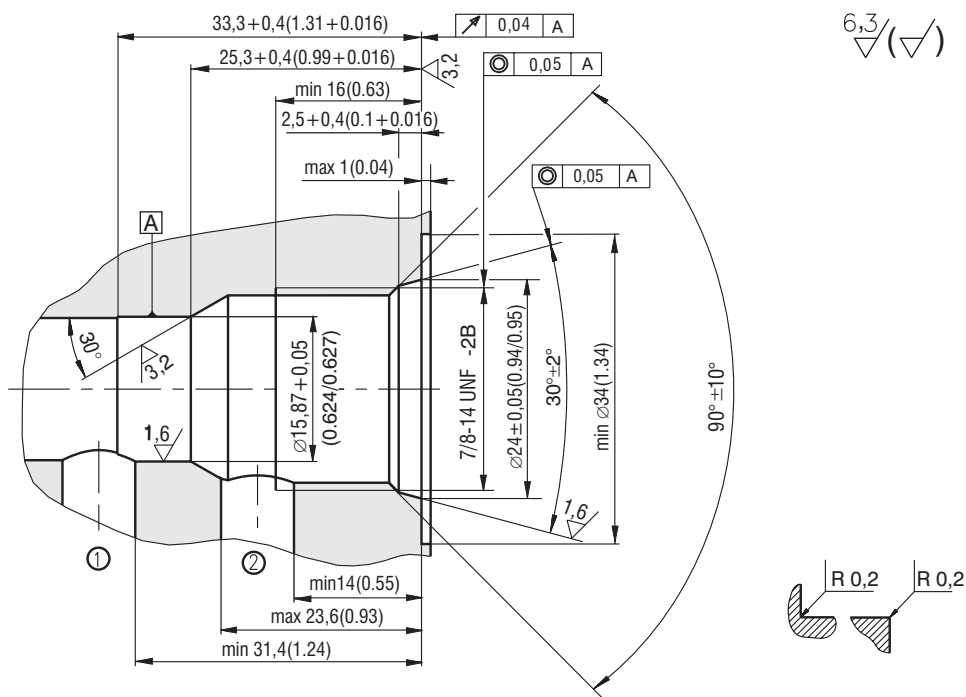

6

Spare Parts

Solenoid coil	Type of the coil		
	E2	E4	E13
Nominal voltage coil	Ordering number		
12 V DC	28145600	28145800	29867600
24 V DC	27824300	27824400	29868600
Main valve	Designation		Ordering number
	SR6H2-B2/HV		29248100
Seal kit (Main valve)	Dimensions, quantity		Ordering number
	Dualseal - PU	O-ring	
	13,47x15,87x3,1 (1pc)	19,4x2,1 (1pc)	18960500
Seal kit (Pilot valve)	Dimensions, quantity		Ordering number
	10,3 x 12,7 x 3,1 (1pc)	17,17 x 1,78 (1pc)	17014300

Caution!

- The packing foil is recyclable.
- The technical information regarding the product presented in this catalogue is for descriptive purposes only. It should not be construed in any case as a guaranteed representation of the product properties in the sense of the law.

ARGO-HYTOS s.r.o. CZ - 543 15 Vrchlábí
 tel.: +420-499-403 111
 e-mail: info.cz@argo-hytos.com
 www.argo-hytos.com

- Reducing valves suitable for mobile applications
- Compact design
- Economic Slip-In

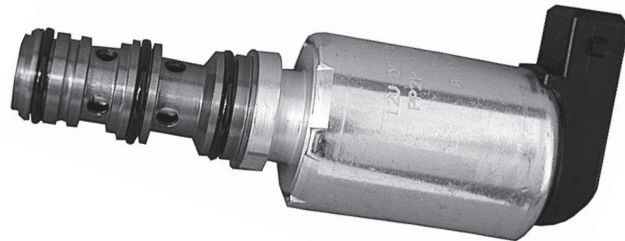
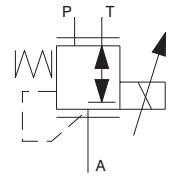

Functional Description

The valve PP2P is the directly controlled 3 way reducing valve controlled by a proportional solenoid. In basic position (zero coil current) the channel A is connected to tank via channel T, where as the channel P is closed. In this state the reduced pressure in channel A equals zero. With increasing the coil current the solenoid (1) force gradually increases and shifts, after overcoming the spring pretension (3), the spool (2) to position gradually decreasing the opened way A-T until the pressure in channel A increases due to opening the way P-A. The reduced pressure is led through the spool boring into the space behind the control spool, where it acts on the area of the small control piston. With increasing the reduced pressure in channel A, the created force acting in direction of the solenoid force increases and assist in overcoming the hydrodynamic

forces acting on spool. For every value of the coil exciting current, there is a state of equilibrium of forces between the solenoid force, spring force, force acting on the smaller spool area and hydrodynamic forces. The reduced pressure is exactly defined by coil current, as shown on the static pressure characteristic. Once the fixing screw is released, it is possible to turn the distributor around its axis by 360° and change thus the connector socket position (6).

The fixing screw (5) and fork (fastening member) (4) form also a part of the supply.

In basic variant a part of the valve is exhibited to influence of the environmental atmosphere and the coil zinc plated.

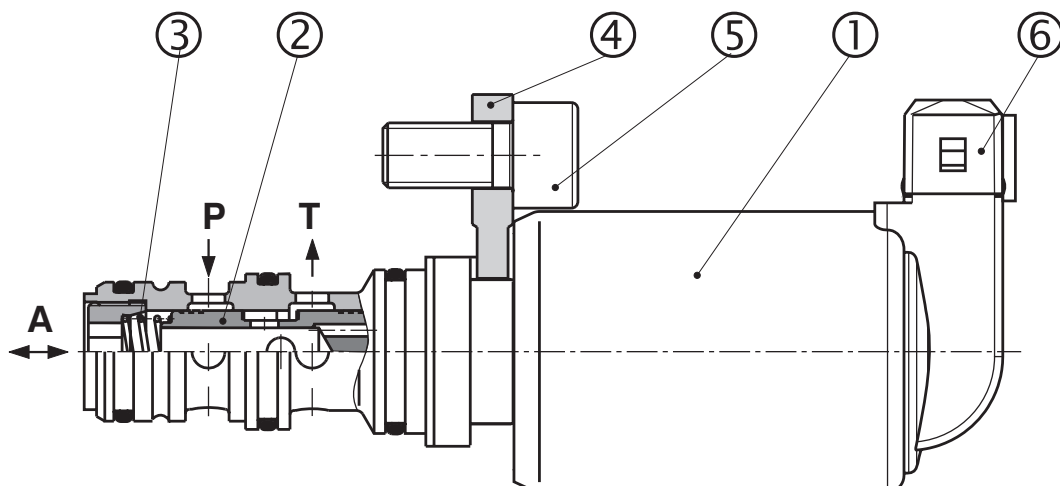

6

Ordering Code

PP2P - / -

Proportional Reducing

Type of construction 1

Valve Cavity
D20 (mm)

Number of operating positions 3

Maximum regulated pressure (bar)

for 12 V 20
for 24 V 32

no designation
V

Seals
NBR
FPM (Viton)

Electronics
E3 with AMP-Junior-Timer-connector
E4 with integrated quenching diode and terminal for AMP-Junior-Timer connector
E12A with DEUTSCH DT 04-2P
E13A with integrated quenching diode and terminal for DEUTSCH DT 04-2P

Nominal supply voltage

12 12 V DC / 1 A
24 24 V DC / 1 A

6

General Data

Design	spool valve	
Mounting mode	D20	
Mounting position	unrestricted	
Flow direction	see the symbol	
Maximum fixing bolt tightening torque	Nm (lbf.ft)	9+2 (6.64+1.48)
Ambient temperature, max.	°C (°F)	-30 ...90 (-22 ...194), +100 °C (212 °F for a short term)

Solenoid Technical Data

Supply voltage	V	12 DC	24 DC
Max. current	A	1	1
Rated resistance at 20 °C (68 °F)	Ω	7.2 ± 6,5%	11,2 ± 6,5%
Duty cycle	%	100	
Pressure tightness (Dynamic)	bar (PSI)	50	
Wire insulation class	200 from IEC 085		
Enclosure type to EN 60 529	IP 67		
Control	Hz	PWM-signal 100	PWM-signal 120
Quenching (E4, E13A)		BZW 06-28B	BZW06-33B

Valve Technical Data

Max. input pressure	bar (PSI)	50 (725)	
Max. regulated pressure	bar (PSI)	20 (290)	32 (464)
Max. flow rate P-A	L/min (GPM)	max. 20 (5.28)	max.16 (4.23)
Hydraulic fluid	Hydraulic oils of power classes (HL, HLP) to DIN 51 524		
Viscosity range	mm ² /s (SUS)	10 ... 800 (49 ...3920)	
Fluid temperature range	°C (°F)	-30 ...90 (-22 ...194), +100 °C (212 °F for a short term)	
Maximum degree of fluid contamination	Class 21/18/15 to ISO 4406		
Response time at 100 % signal	ms	< 50	

p-Q Characteristics

Measured at $v = 32 \text{ mm}^2/\text{s}$ (156 SUS)

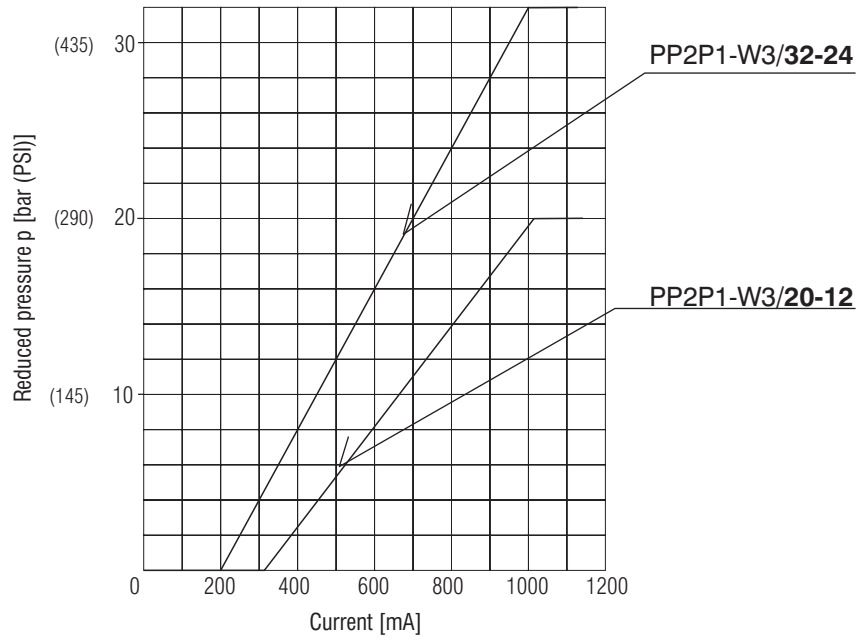

Δp -Q Characteristics

Measured at $v = 32 \text{ mm}^2/\text{s}$ (156 SUS)

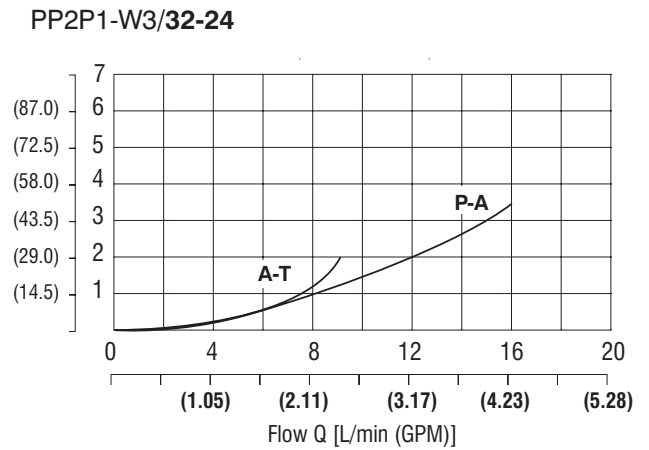
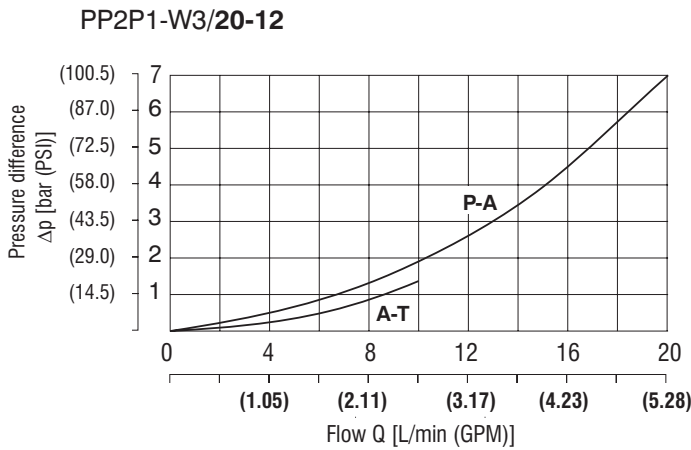

Valve Body

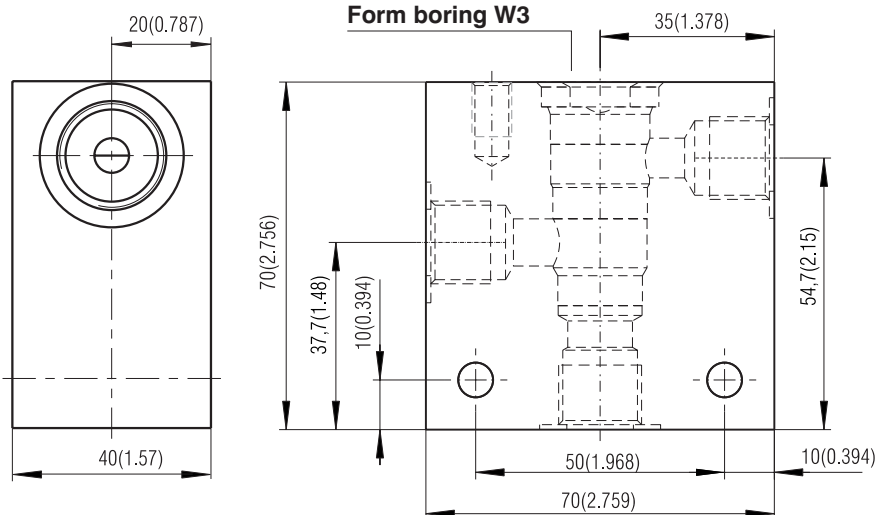

Form boring	Connecting size	Type code	Body material	Operating pressures
W	G3/8	SB-W3-0103AL	Aluminium	250 bar (3626 PSI)

Valve Dimensions

Dimensions in millimeters and (inches)

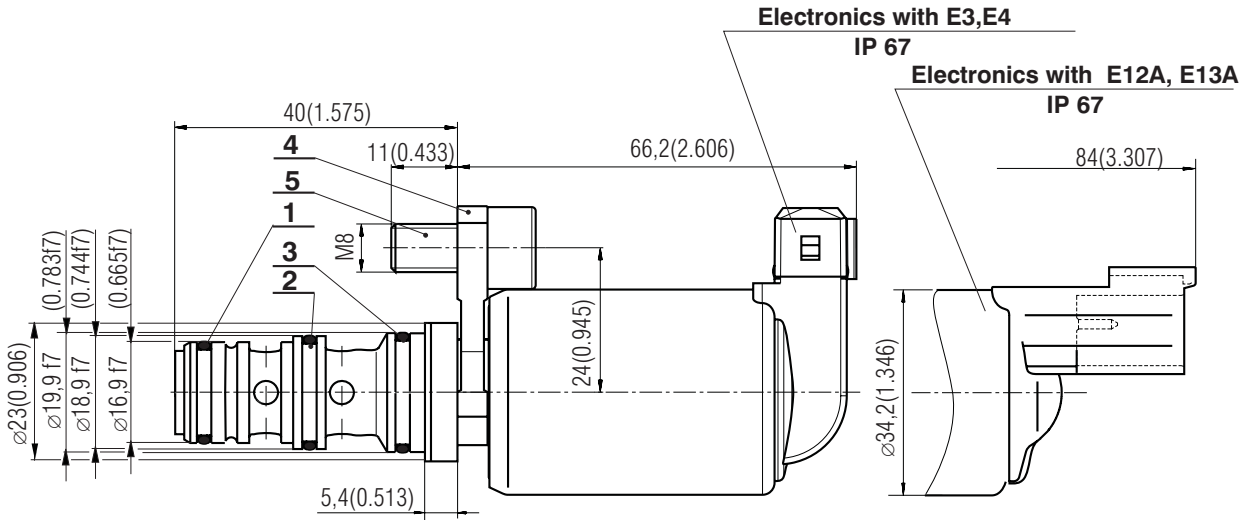

Mitgeliefert

- 1 O-Ring 14x1,78 NBR 70 (1pc.)
- 2 O-Ring 16x1,8 NBR 70 (1pc.)
- 3 O-Ring 17x1,8 NBR 70 (1pc.)
- 4 Fork Slip-In M8
- 5 Mounting hole M8x16

Cavity

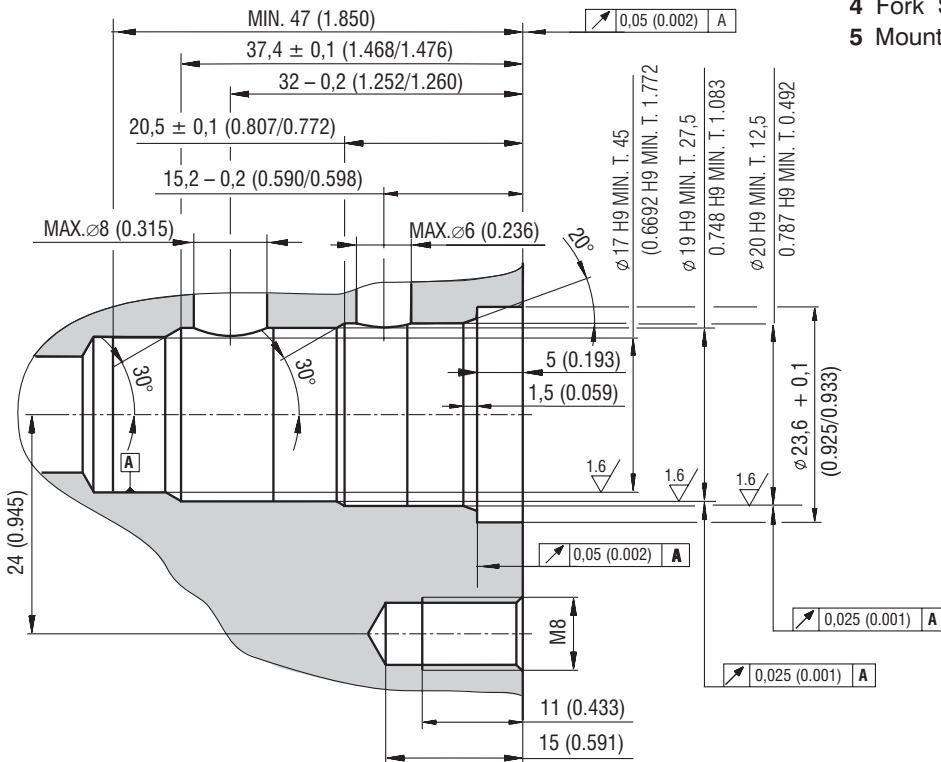

6

Spare Parts

Seak kit

Type	Dimensions, number			Ordering number Seal kit
Standard (NBR70)	14x1,78 (1pc.)	16x1,8 (1pc.)	17x1,8 (1pc.)	16961300
Fork+Bolt M8	Fork SLIP-IN M8 (1pc.)	Bolt M8x16 021143 Zn	PO-A (1pc.)	16961500

Caution!

- The technical information regarding the product presented in this catalogue is for descriptive purposes only. It should not be construed in any case as a guaranteed representation of the product properties in the sense of the law.

ARGO-HYTOS s.r.o. CZ - 543 15 Vrchlaví
 Tel.: +420-499-403111, Fax: +420-499-403421
 E-mail: sales.cz@argo-hytos.com
 www.argo-hytos.com

- Reducing valves suitable for mobile applications
- Compact design
- Installation dimensions to ISO 7789

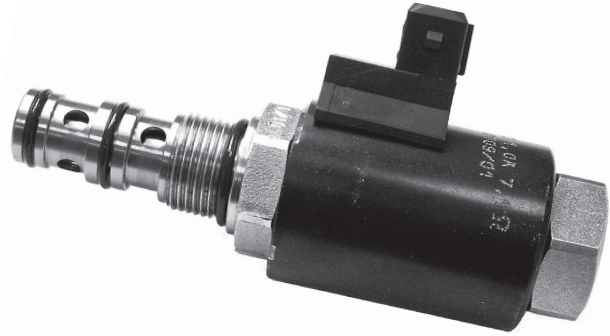
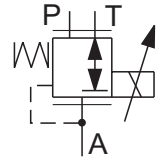

Functional Description

The reducing valve PVRM1 is a directly operated 3-way valve controlled by proportional solenoid (1). In the de-energized state, the spring (4) holds the control spool (3) in relation to the housing in such a position that the input pressure in port P is blocked, whereas the port A is connected with tank. The electric current through the solenoid shifts the spool and closes gradually the return port and opens the inlet to the output port A. The reduced pressure in port A brought to the solenoid room acts on the differential area of the spool, this being

created by adapter (5). The solenoid pushes on the spool with a force, which is proportional to the current. Acting against this force is the force created by the reduced pressure acting on the differential area. In a balanced state, both the forces are equal. This arrangement ensures the proportional relation between the reduced pressure in port A and the control current. The basic surface treatment of the solenoid is blackened, other parts are zinc coated.

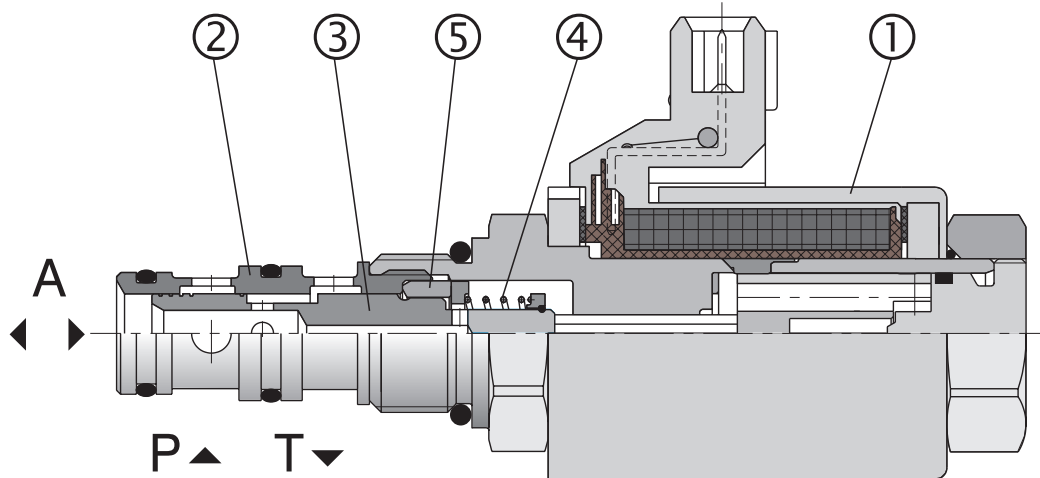

General Data

Design	spool valve	
Mounting mode	screw-in cartridge M20 x 1.5	
Mounting position	optional	
Flow direction	see the symbol	
Ambient temperature, max.	°C (°F)	-30 ...90 (-22 ...194), +100 °C (212 °F for a short term)

Solenoid Technical Data

Supply voltage	V	12
Rated current	A	1
Rated resistance at 20 °C (68 °F)	Ω	7,1 ± 6.5 %
Rated power	W	22
Duty cycle	%	100
Pressure tightness (dynamic)	bar (PSI)	50 (725.19)
Wire insulation class		200 from DIN IEC 60085
Electric connection		2- poles AMP Junior-Timer
Enclosure type to EN 60529		IP 65
Control		PWM-signal 100 Hz
Quenching		BZW 06 P28B

Valve Technical Data

Max. input pressure	bar (PSI)	50 (725.19)
Operating pressure	bar (PSI)	20 (289.86)
Max. flow rate	L/min (US GPM)	20 (5.29)
Hydraulic fluid		Hydraulic oils of power classes (HL, HLP) to DIN 51524
Viscosity range	mm ² /s (SUS)	10 ... 800 (49 ... 3920)
Fluid temperature range	°C (°F)	-30 ...90 (-22 ...194), +100 °C (212 °F for a short term)
Maximum degree of fluid contamination		Class 21/18/15 to ISO 4406
Response time at 100 % signal	ms	< 50

Valve Dimensions Dimensions in mm (inches)

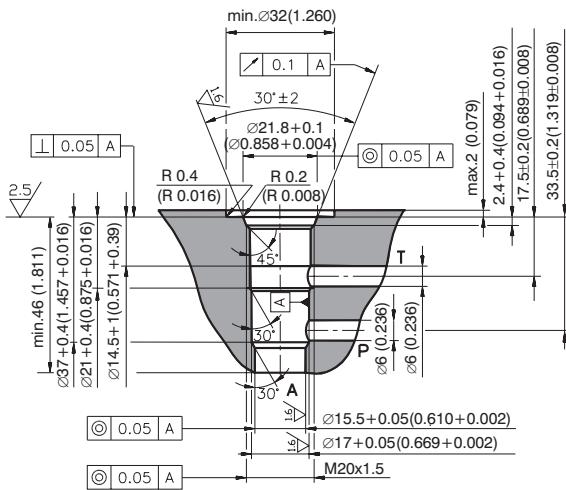
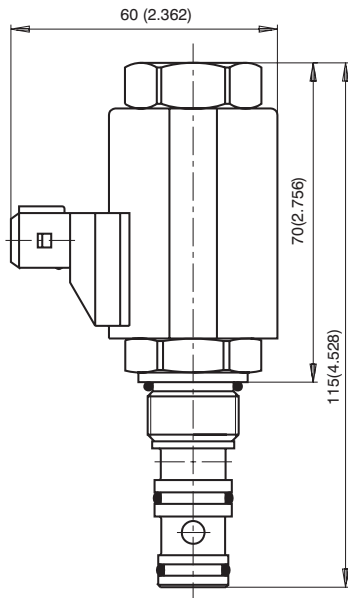

p-I Characteristics

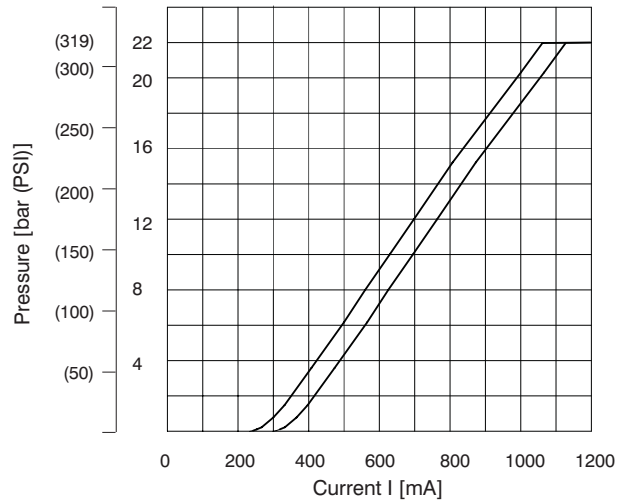

Δp-Q Characteristics

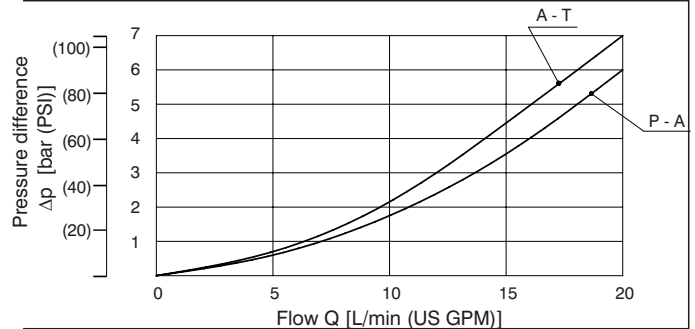

Caution!

- The technical information regarding the product presented in this catalogue is for descriptive purposes only. It should not be construed in any case as a guaranteed representation of the product properties in the sense of the law.

ARGO-HYTOS s.r.o. CZ - 543 15 Vrchlabí
 Tel.: +420-499-403111, Fax: +420-499-403421
 E-mail: sales.cz@argo-hytos.com
 www.argo-hytos.com

- Reducing valves suitable for mobile applications
- Compact design
- Installation dimensions to ISO 7789

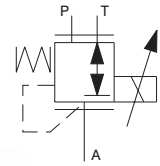

Functional Description

The valve PVRM3 is the directly controlled 3 way [2] reducing valve controlled by a proportional solenoid. In basic position (zero coil current) the channel A is connected to tank via channel T, whereas the channel P is closed. In this state the reduced pressure in channel A equals zero. With increasing the coil current the solenoid force gradually increases [1] and shifts, after overcoming the spring pretension [4], the spool [3] to position gradually decreasing the opened way A-T until the pressure in channel A increases due to opening the way P-A. The reduced pressure is led through the spool boring into the space of the actuating system, where it

acts on the smaller spool are. With increasing the reduced pressure in channel A, the created force acting in direction of the solenoid force increases and assist in overcoming the hydrodynamic forces acting on spool. For every value of the coil exciting current, there is a state of equilibrium of forces between the solenoid force, spring force, force acting on the smaller spool area and hydrodynamic forces. The reduced pressure is exactly defined by coil current, as shown on the static pressure characteristic. In basic variant a part of the valve is exhibited to influence of the environmental atmosphere and the coil zinc plated.

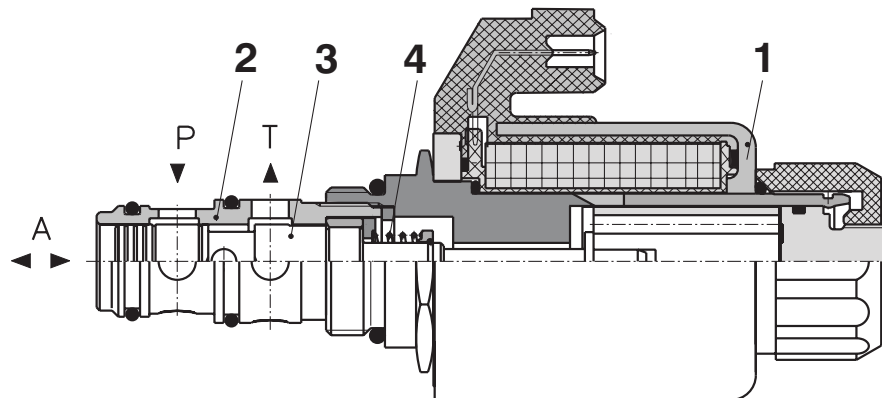

General Data

Design	spool valve	
Mounting mode	screw-in cartridge M24 x 1.5	
Mounting position	unrestricted	
Flow direction	see the symbol	
Ambient temperature, max.	°C (°F)	-20 ... 100 (-4 ... 212)

Solenoid Technical Data

Supply voltage	V	9 .. 15
Rated current	A	1,5
Rated resistance at 20 °C (68 °F)	Ω	5 ± 0,25
Duty cycle	%	100
Wire insulation class	200 from IEC 085	
Electric connection	2- poles AMP Junior-Timer AXIAL	
Enclosure type EN 60 529	IP 65	
Control	Hz	PWM-signal 150

Valve Technical Data

Max. input pressure	bar (PSI)	50 (725.19)
Operating pressure	bar (PSI)	18,5 (268.32)
Max. flow rate	L/min (GPM)	40 (10.57)
Hydraulic fluid		Hydraulic oils of power classes (HL, HLP) to DIN 51524
Viscosity range	mm ² /s (SUS)	10 ... 400 (61.45 ... 1840)
Fluid temperature range	°C (°F)	-20 ... 100 (-4 ... 212)
Maximum degree of fluid contamination		Class 21/18/15 to ISO 4406

Valve Dimensions Dimensions in mm (inches) p-I Characteristics

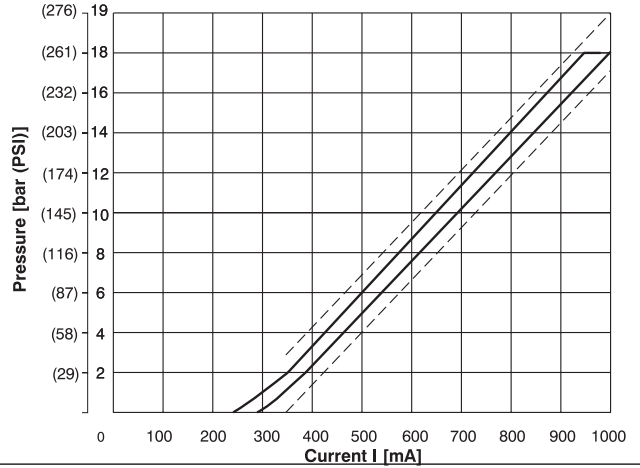
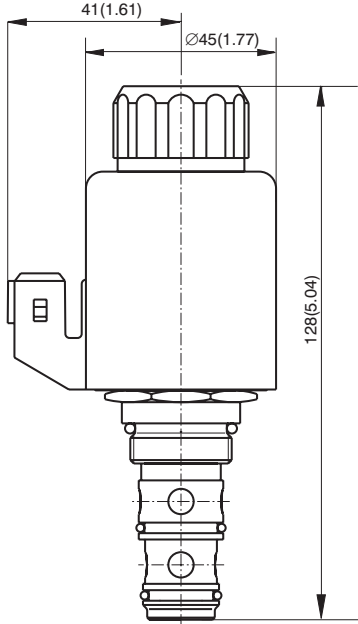

Δp-Q Characteristics

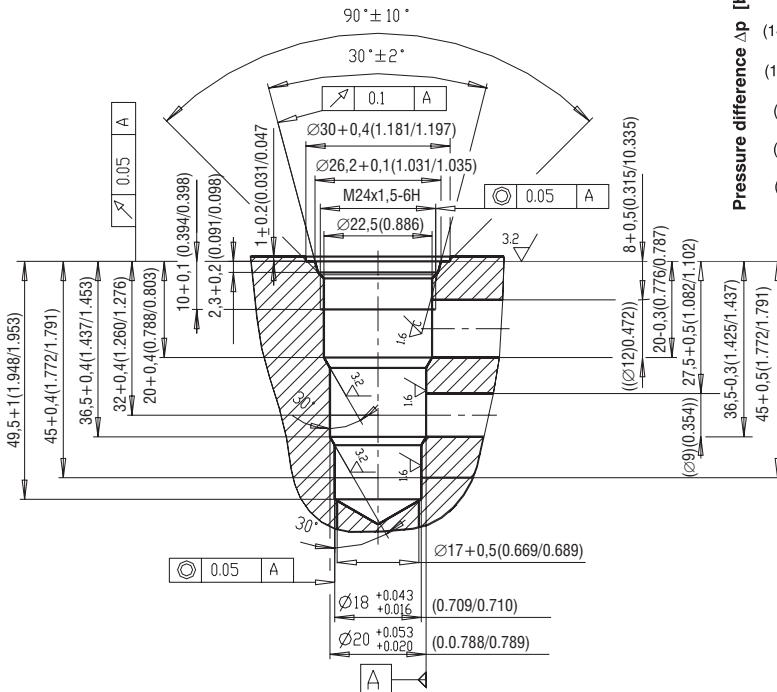
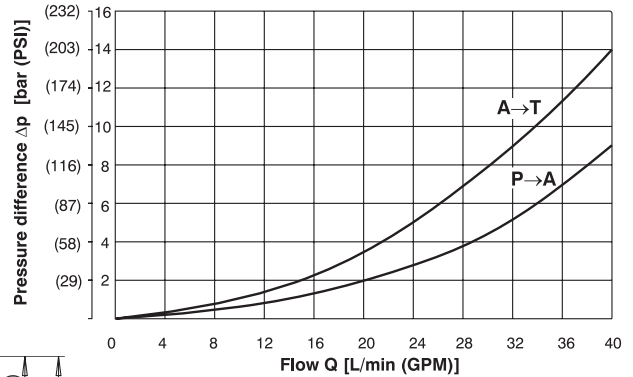

Caution!

- The packing foil is recyclable. The protective plate can be returned to manufacturer.
- The technical information regarding the product presented in this catalogue is for descriptive purposes only. It should not be construed in any case as a guaranteed representation of the product properties in the sense of the law.

ARGO-HYTOS s.r.o. CZ - 543 15 Vrchlabí
 Tel.: +420-499-403111, Fax: +420-499-403421
 E-mail: sales.cz@argo-hytos.com
 www.argo-hytos.com

- Screw-in cartridge design
- Pilot operated
- Three pressure ranges
- Pressure output proportional to DC current input

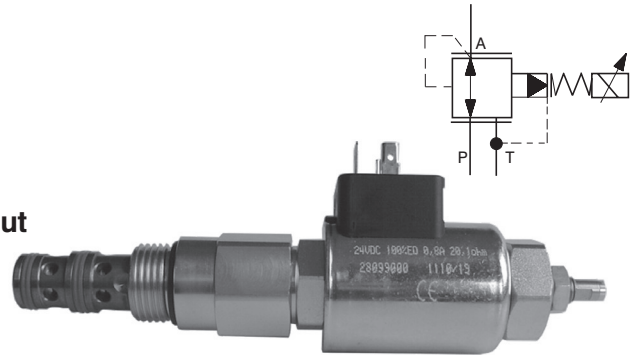

Functional Description

The pressure valves SP4P2-B3 are pilot operated screw-in cartridge proportional pressure reducing valves designed as 3 way valves, i.e. with pressure protection of the secondary circuit.

The complete reducing valve consists of a body (2) with thread 7/8-14 UNF, control spool (3), spring (4) and pilot stage of SR1P2-A2 valve.

In the basic position the flow from the primary circuit flows to consumer ports A. In this situation the spring chamber is vented to Tank line through nozzle (5) and (6).

When the DC current is applied to solenoid (10) at spring (9) increases force to the seat (8) and it continuously closes.

Build up pressure acts on spool (3) in spring chamber (4) through orifices (6). Then the reduced pressure at port A is continuously controlled and compared with the pressure preset from pilot stage. If any control error appears, the respective control action takes place and the reduced pressure returns to its pre-set value. If pressure behind the valve increases due to the effect of

external load acting on the user, the control spool (3) shifts further against the spring, the reducing metering edge closes and the second metering edge opens. The fluid passes through the „third way“ to port T. The control flow of the pilot stage valve (7) is also connected to port T.

Pilot stage valve SR1P2-A2 (catalogue no. HA 5122) can be ordered separately as a built-in proportional directly operated pressure relief valve. The main stage of the valve can be also ordered separately – see spare parts.

The valve body and the adjustment screw are zinc coated.

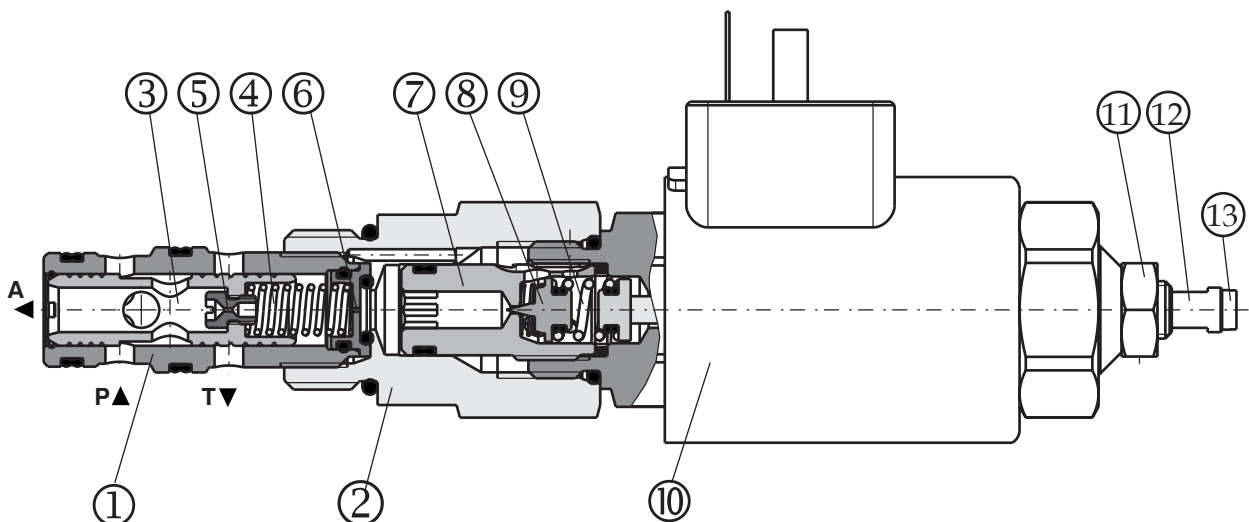

Ordering Code

SP4P2-B3 / -

Proportional Pilot Operated Pressure Reducing Valve 7/8-14UNF

High performance

H

Pressure range

up to 120 bar (1740 PSI)
up to 210 bar (3046 PSI)
up to 350 bar (5076 PSI)

12
21
35

Nominal solenoid supply voltage

12 V DC
24 V DC

12
24

V

Seals

Viton (FPM)

Type of solenoid coil

E2

Connector EN 175301-803-A
with quenching diode

E4

Connector AMP Junior Timer with
quenching diode

E13

Connector Deutsch DT04-2P with
quenching diode

Other coils on demand see catalog HA8007.

Technical Data

Valve size		B3
Cartridge cavity		7/8-14 UNF-2A
Maximum operating pressure at ports P	bar (PSI)	350 (5076)
Maximum operating pressure at ports T*	bar (PSI)	100 (1450)
Flow range	L/min (GPM)	0 ÷ 60 (0 ÷ 15.85)
Hydraulic fluid		Hydraulic oils of power classes (HL, HLP) to DIN 51524
Fluid temperature range (FPM)	°C (°F)	-20 ... 120 (-4 ... 248)
Ambient temperature range	°C (°F)	-20 ... 80 (-4 ... 176)
Viscosity range	mm ² /s (SUS)	10 ... 500 (49 ... 2450)
Duty cycle	%	100
Enclosure type to EN 60 529		IP 67 (IP 65)
Maximum valve tightening torque	Nm (lbf.ft)	50+5 (36.87+3.68)
Optimum dither control	Hz	250
Maximum degree of fluid contamination		Class 21/18/15 according to ISO 4406
Minimum reachable pressure for Q = 0 L/min (0 GPM)	bar (PSI)	~ 6 (87)
Hysteresis	%	< 5
Weight	kg (lb)	0,595 (0.312)
Mounting position		When possible, the valve should be mounted with solenoid faced down.
Valve body (data shee HA 0018)		SB-B3

*Pressure in T influences $p = f(l)$ a $p = f(Q)$ valve performance

Solenoid Technical Data

Type of coil	V	12 DC	24 DC
Limit current	A	1	0,6
Resistance at 20 °C (68 °F)	Ω	6,5	20,8
Quenching diode (E2, E4, E13)		BZW06-19B	BZW06-33B

Valve Dimensions

Dimensions in millimeters and (inches)

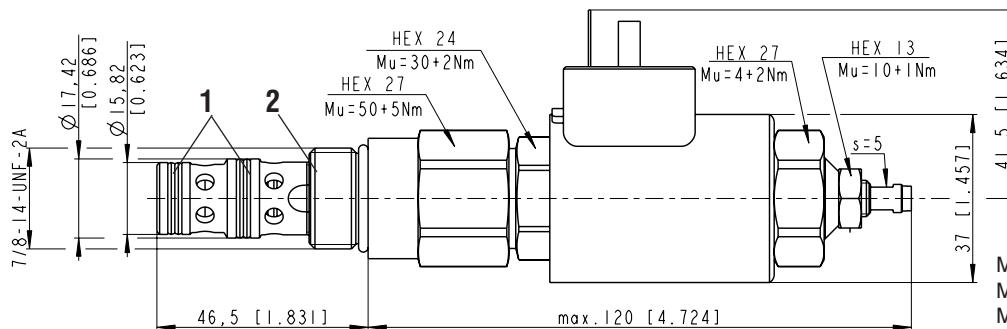

Seal kit (Main valve)

- see Spare Parts
- 1. Dualseal - PU
- 2. O-ring - Viton

Mu=[50+5 Nm (37+3.68 lb.ft)]
Mu=[30+2 Nm (22+1.47 lb.ft)]
Mu=[4+2 Nm (2.95+1.47 lb.ft)]
Mu=[10+1 Nm (7.37+0.73 lb.ft)]

p-I Characteristics

Measured at $v = 32 \text{ mm}^2/\text{s}$ (156 SUS)

$p = f(I), Q = 0 \text{ dm}^3 \cdot \text{min}^{-1}$ (Port A close)

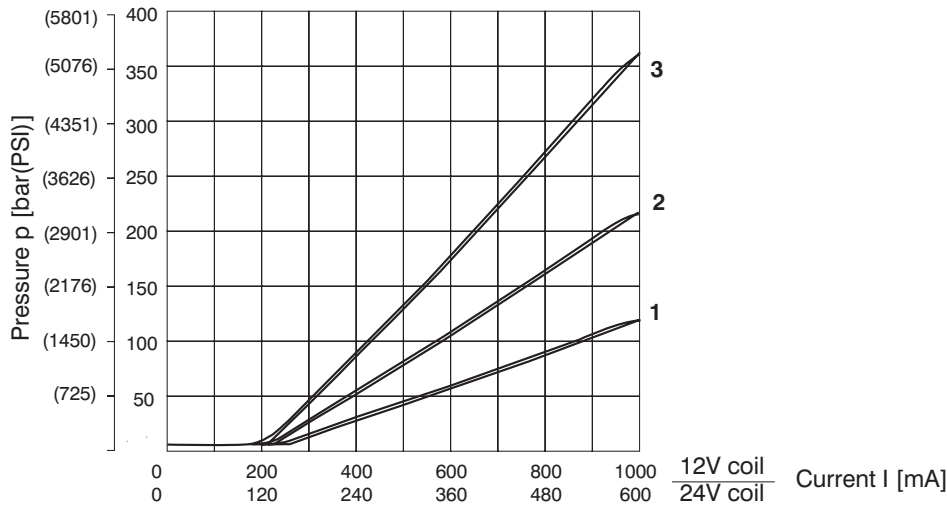

p-Q Characteristics

Measured at $v = 32 \text{ mm}^2/\text{s}$ (156 SUS)

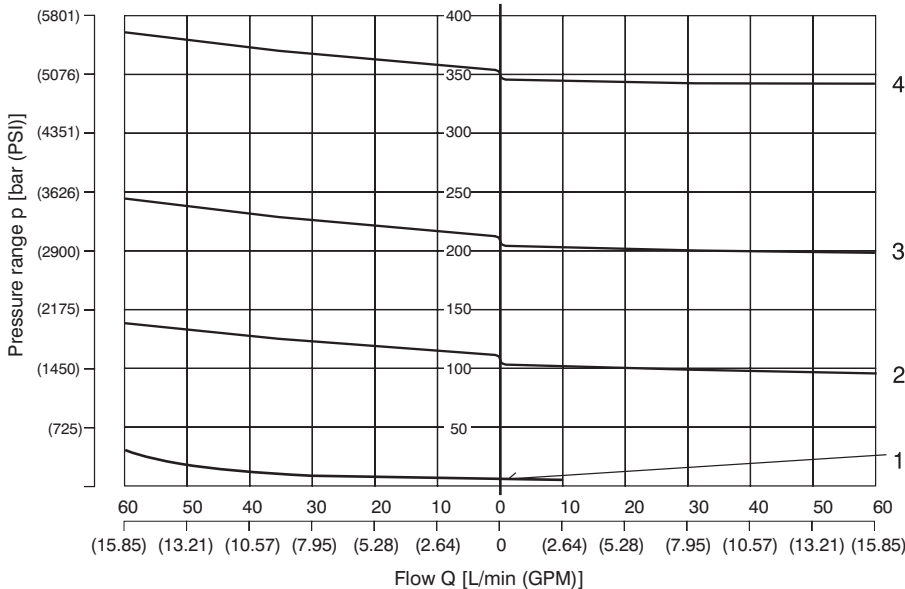

Type of the Solenoid Coil

Note:

Example of most frequent coil types.

For complete range valve coils with technical informatik about voltage, enclosure type, terminal box please refer to coil data sheet HA 8007.

Coil example	Solenoid	Connector	Type code
<p>Type E2</p>	12 VDC	Connector EN 175301-803-A with quenching diode	C19B-01200E2-6,5NA
	24 VDC	Connector EN 175301-803-A with quenching diode	C19B-02400E2-20,1NA
	12 VDC	Connector AMP Junior Timer with quenching diode	C19B-01200E4-6,5NA
	24 VDC	Connector AMP Junior Timer with quenching diode	C19B-02400E4-20,1NA
	12 VDC	Connector Deutsch with quenching diode	C19B-01200E13-6,5NA
	24 VDC	Connector Deutsch with quenching diode	C19B-02400E13-20,8NA

Cavity

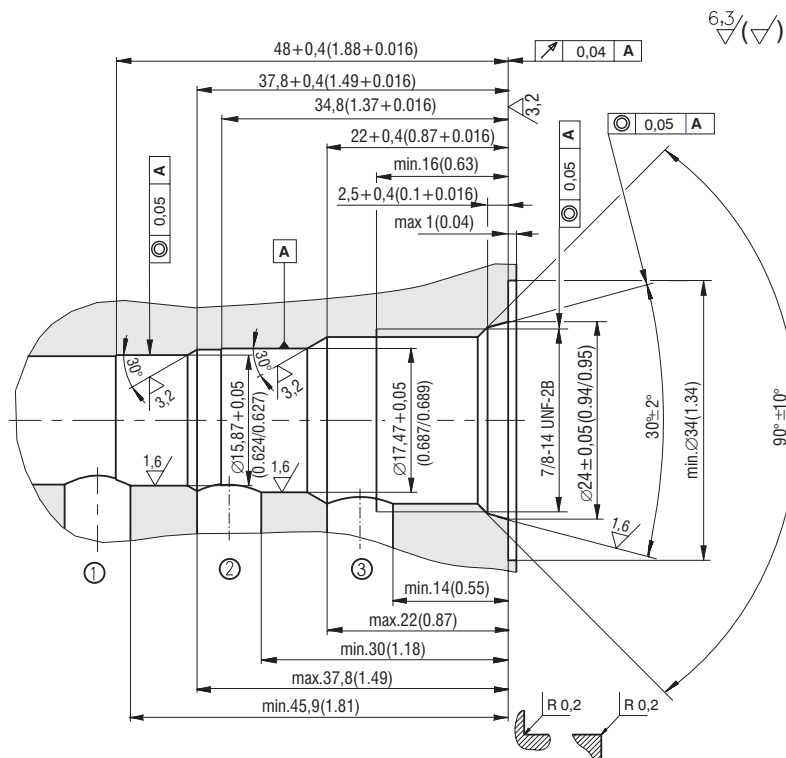

Spare Parts

Solenoid coil	Type of the coil		
	E2	E4	E13
Nominal voltage coil	Ordering number		
12 V DC	28145600	28145800	29867600
24 V DC	27824300	27824400	29868600
Main valve	Designation		Ordering number
	SP6H2-B3/HV		29248000
Seal kit (Main valve)	Dimensions, quantity		Ordering number
	Dualseal - PU		O-ring
	13,47x15,87x 3,1(1pc)	17,47x15,07x3,1 (1pc)	19,4x2,1 (1pc)
Seal kit (Pilot valve)	Dimensions, quantity		Ordering number
	Dualseal - PU		O-ring
	10,3 x 12,7 x 3,1 (1pc)		17,17 x 1,78 (1pc)

Caution!

- The packing foil is recyclable.
- The technical information regarding the product presented in this catalogue is for descriptive purposes only. It should not be construed in any case as a guaranteed representation of the product properties in the sense of the law.

ARGO-HYTOS s.r.o. CZ - 543 15 Vrchlábí
 tel.: +420-499-403 111
 e-mail: info.cz@argo-hytos.com
 www.argo-hytos.com

- Microcontroller design
- Independent adjustments (Incl. ramp up and ramp down)
- 3 digit extra bright seven segment LED display
- Large, easy-to-use adjustments and readout
- Display and adjust actual values (current & voltage)
- Wide range of supply voltage
- User selectable input type through menu setup (ex: 0 to 5V, 0 to 10 V, 4 to 20 mA)
- Wide ramp time range (0 to 99,5 sec)
- Simple control with analog input, locally supplied reference voltage
- Energy efficient PWM circuit, no heat sink required
- Electronic limiting circuit/ short circuit proof
- Reverse polarity, command input protection
- Load can be connected and disconnected live



6

Functional Description

The control electronics is intended for controlling of proportional valves with one control solenoid. Its great advantage is a miniature design in form of a socket for a standardized DIN connector base. On the electronic card's top surface, two revolving selectors, a terminal block for connecting of supply and control wires, and three-position LED display are attached. The selector marked as "SELECT" serves for selecting of parameters

for setting up. The second selector, marked as "ADJUST", serves for setting up of a desired value. In a basic mode, the display shows an input/output parameter value; conversely, in a setting mode, a selected parameter abbreviation and the value being set up are indicated. Setting up of an input control signal selected type .

Technical Data

Operating Voltage	V DC	9 - 36		
Maximum output current	A	3,00		
Input signal		0 - 5 [V]	0 - 10 [V]	4 - 20 [mA]
Maximum ramp time	s	99,5		
PWM / Dither frequency	Hz	40 - 450		
Linearity	%	1		
Operating Temperature	°C	- 40 ... 75		
Recommended cross-section of lead-in wires	mm ²	0,5 ... 0,75		
Protection Grade		IP 65		

Attention:

A cable with a circular cross-section and outside diameter of 4 to 6mm should be used for the electronics supply, only this way the declared degree of IP protection can be secured.

Schematics

1) EXTERNAL INPUT SIGNAL CONNECTION

("in" set to "10")

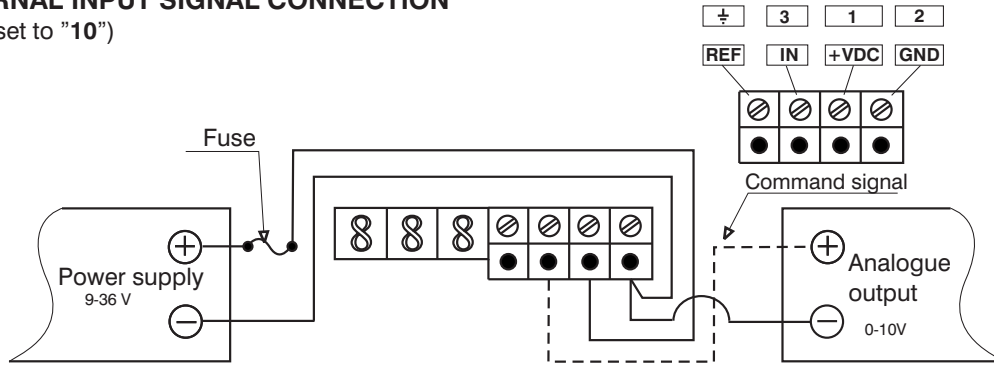

2) POTENTIOMETER CONNECTION

("in" set to "5")

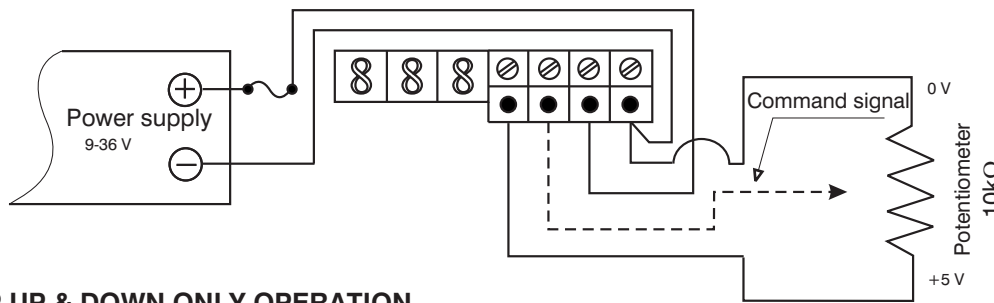

3) RAMP UP & DOWN ONLY OPERATION

("in" set to "5")

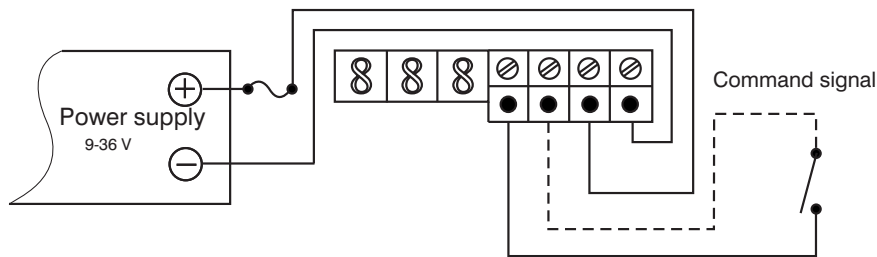

4) EXTERNAL INPUT SIGNAL CONNECTION 4-20 mA

("in" set to "420")

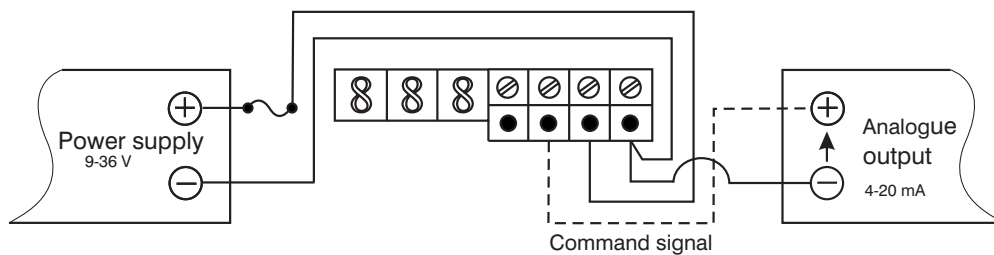

4) TWO WIRE TRANSMITTER INPUT CONNECTION 4-20 mA

("in" set to "420")

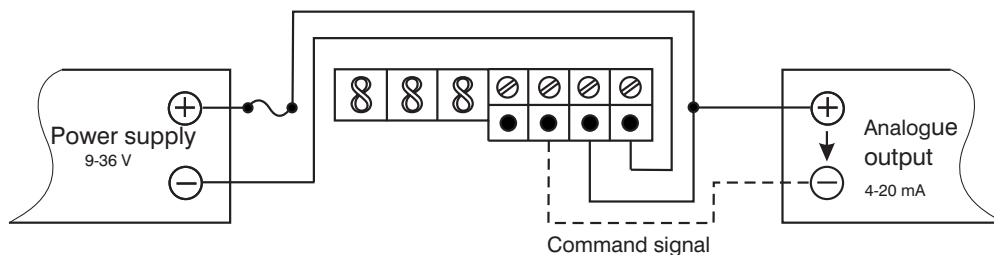

Set-up Procedure

Attention:

- Prior to setting up parameters, you must select proper Input Signal setting for your system.
Voltage signal from 0 to 10 V is standardly preset.
 - Applying improper Input Signal to wrong setting on the Driver may be damaging to Driver Unit and may cause driver to fault to „Error“ Status mode .
1. At power up, the display will show either the output current signal or the input signal (Default display setting shows the output signal). The decimal point will be flashing.
 2. Rotate „SELECT“ to enter the set-up mode. Parameter abbreviation is indicated on the display
 3. When you reach the setting you want to modify, rotate „ADJUST“ up or down to the desired value.
 4. To modify another setting, rotate „SELECT“ again and repeat..
 5. The Driver is fully functional during the set-up procedure with any adjustments effective immediately.
 6. In order to write the new settings in the memory and return to normal mode of operation, rotate „SELECT“ until the display shows „SR“ and then rotate „ADJUST“ from 0 to 1 or wait for 100 seconds.
 7. If you do not want to save the new settings you have just modified, you must disconnect the Driver from the power supply before the end of the 100 seconds to restore precious settings.
 8. After saving parameters to memory, the decimal point will be flashing and the Driver display will be back showing either the output current signal or input signal depending on your „di“ selection.
 9. To start over completely, you can restore the factory settings by rotating „SELECT“ to „rFP“ and then rotate „ADJUST“ up from 0 to 10 for the display to reset. (NOTE for Step 9: You may have to adjust your Input Signal Setting again if you reset to factory settings.)

Table settings

Parameter Abbreviation	Parameter	Adjustable Range
Hi	HIGH, Maximum Current Output	0,20 – 3,00 A
Lo	LOW, Minimum Current Output	0,00 – 2,99 A
rUP	RAMP UP, Time for Output to Increase from min to max	0,0 – 99,5 s
rdn	RAMP DOWN, Time for Output to decrease from max to min	0,0 – 99,5 s
Cdb	area of insensibility – an output current for a coil is zero, until a control signal will exceed a threshold of insensibility (the threshold is expressed in % of the control signal maximum value)	0 – 5 %
dFr	DITHER FREQUENCY, 40 (40Hz) to 450 (450Hz)	40 – 450 Hz
in 5 10 420	Input control signal type selection - Voltage signal - Voltage signal - Current signal	0 – 5 V 0 – 10 V 4 – 20 mA
di 0 1	Signal value indication for checking or problem solving purposes - Command signal [V] or[mA] - Output signal [A] Flashing decimal point is an indicator for present display mode*: - Fast Flashing decimal point, several flashes per second indicates – Command signal (di = 0) - Slow Flashing decimal point, 1 per second indicates) – Output signal (di = 1) - No Flashing decimal point or No decimal point indicates display in SETTING/ADJUST	
SR	SAVE SETTINGS	
rFP	RESET FACTORY PARAMETERS	
Err 0 1 2	ERROR DETECTION STATE, Short Circuit, Reverse polarity protection and detection - Error 0 - No Errors - Error 1 - Overcurrent in driver likely due to short circuit in Solenoid - Error 2 - Current exceeding 20 mA in „4 to 20mA“ input mode	
CLr	CLEAR ERROR, Clears Driver of Error State	

NOTE: When adjusting the HI and LO parameters, note the HI parameter value cannot be adjusted below the LO parameter value as well the LO parameter value cannot exceed the HI parameter value.

Range Adjustment

Adjustment of Maximum:

(High) / parameter „Hi“

Maximum Current output **0,20 až 3,00 A**

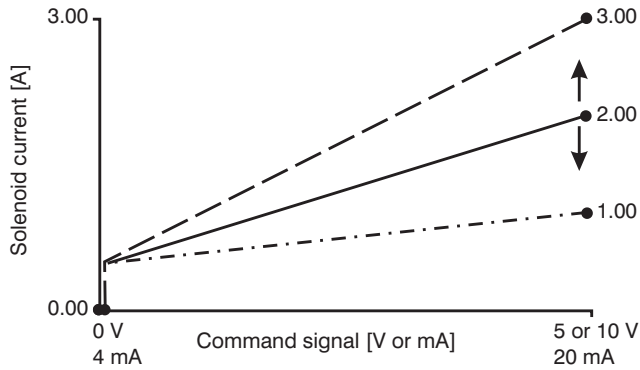

Adjustment of minimum

(Low) / parameter „Lo“

Maximum Current output **0,00 až 2,99 A**

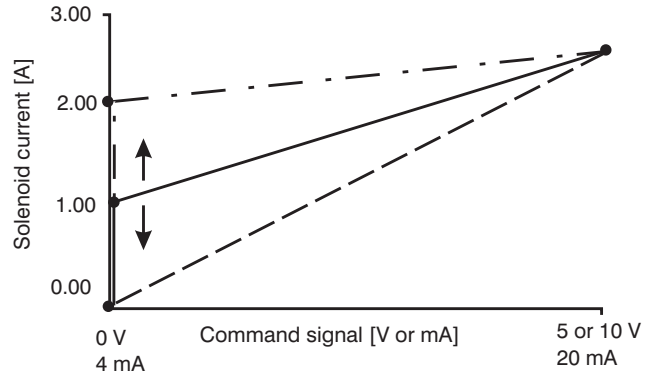

Adjustment Ramp

(Ramp up) / parameter „rUP“

Time for Output to Increase from min to max, **0 až 99,5 s**

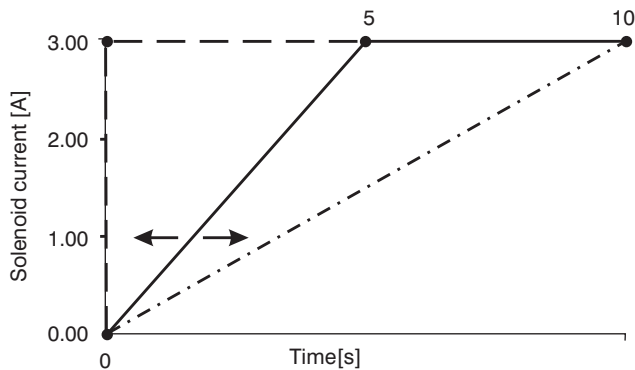

Adjustment Ramp

(Ramp down) / parameter „rdn“

Time for Output to Decrease from max to min **0 až 99,5 s**

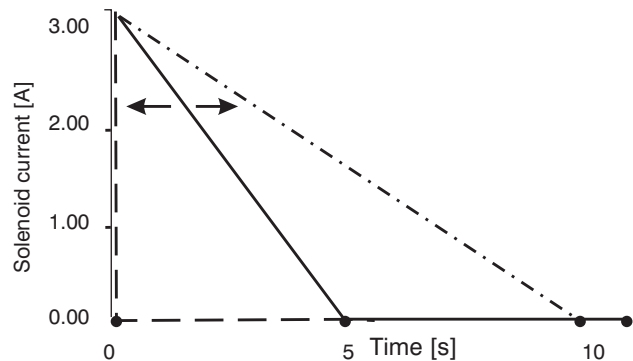

Adjustment (Command deadband) / parameter „Cdb“

Output disabled if command signal less than deadband **0 až 5 %** of the maximum Command signal

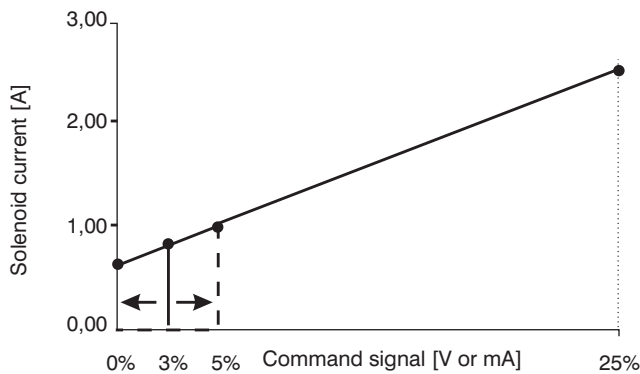

DITHER FREQUENCY / parameter „dFr“

Frequency settable in a range of **40 až 450 Hz**

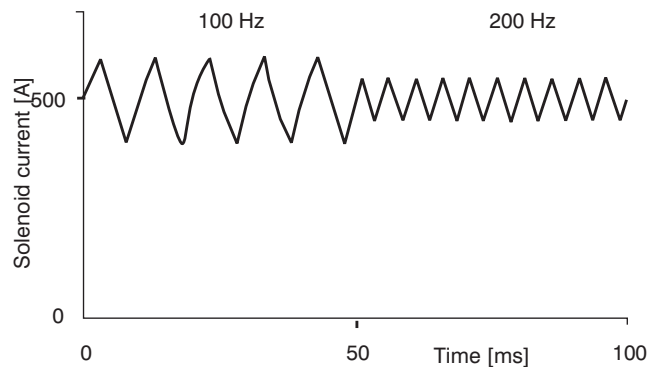

Dimensions

Dimensions in millimetres (inches)

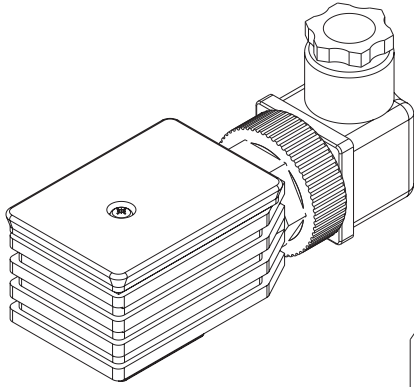

DETAIL A
M 2:1

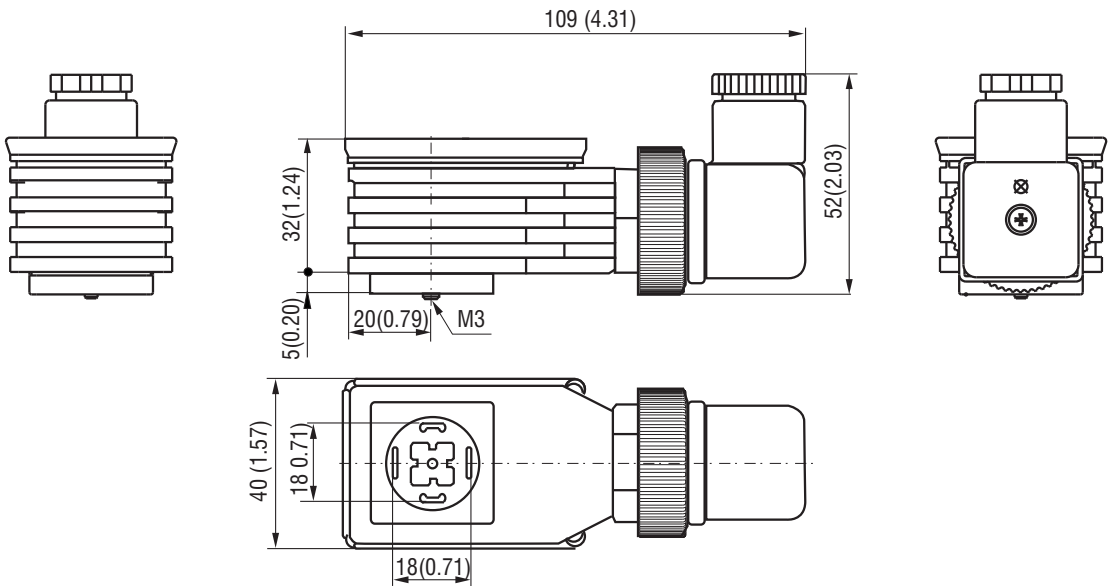
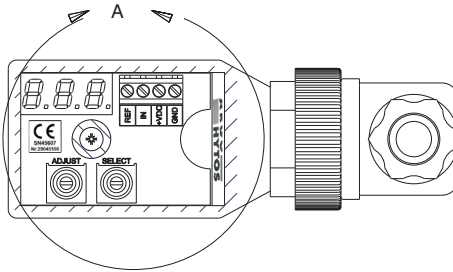
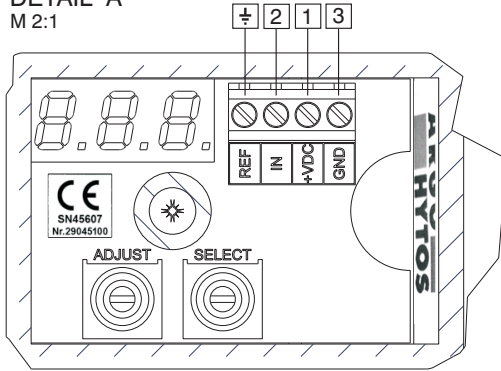

Caution!

- The packing foil is recyclable.
- The technical information regarding the product presented in this catalogue is for descriptive purposes only. It should not be construed in any case as a guaranteed representation of the product properties in the sense of the law.

ARGO-HYTOS s.r.o. CZ - 543 15 Vrchlabí
Tel.: +420-499-403 111
E-mail: info.cz@argo-hytos.com
www.argo-hytos.com

- Electronic control units developed to control proportional valves PRM2
- Nominal size 04, 06,10 of proportional valves
- Compact units mounted on a strip 35/7.5 to DIN 50 022
- Enclosure type - IP20



EL3E-24A

EL3E-24AB

Functional Description

The external model of the analogue electronics EL3E-12 and EL3E-24 have been developed for controlling the proportional directional valves of the series PRM2 with one solenoid (EL3E-xxA) or two solenoids (EL3E-xxAB). The electronics performs the function of an amplifier and former of the input control signals with the defined transfer characteristic. The main advantages of the external electronics model are the possibility of its mounting, together with the other electronic components, on a strip 35,7x7, 5mm to DIN 50 022 and situating into a determined space, the reduction of the

necessary mounting space thanks to the absence of the box with the integrated electronics and protection of the electronics against undesirable vibrations. The easy accessibility of the electronics setting elements (trims) enables a more operative changing of the adjustable parameters of the controlled proportional directional valves.

The electric design of the external electronics is identical with the design of the integrated electronics situated directly on the solenoid coil. The arrangement of the setting elements and the electric connection is adapted

Ordering Code

EL3E-	<input type="checkbox"/>	<input type="checkbox"/>	
External analogue electronics			
Rated supply voltage	12V	24V	
	12	24	
			Type
	A		External electronics for proportional directional valves with one solenoid
	AB		External electronics for proportional directional valves with two solenoid

Technical Parameters

Technical parameters EL3E-12	Specification
Nominal supply voltage	12 V DC
Range of the supply voltage	11,2...14,7 V DC
Maximum output current	2,4 A for $R < 4 \Omega$
Input power	max. 25 W
Stabilized voltage for potentiometer control	5 V DC / 100 mA
Control signal type	0...20 mA 4...20 mA +/- 5 V 0...+5 V $U_{CC}/2 \pm 5 V$
Setting range of ramp functions	0,05...3 s
Dither frequency	60 / 90 Hz
Dither amplitude	0...30 %
Enclosure type	IP 20
Operating ambient temperature	-20 °C...+50 °C
External dimensions	40 x 79 x 85,5 mm
Attachment	On a strip 35,7x7,5 mm to DIN 50 022
Weight	125 g
Technical parameters EL3E- 24	Specification
Nominal supply voltage	24 V DC
Range of the supply voltage	20...30 V DC
Maximum output current	1,5 A for $R < 10 \Omega$
Input power	max. 25 W
Stabilized voltage for potentiometer control	10 V DC / 100 mA
Control signal type	0...20 mA 4...20 mA +/-10 V 0...+10 V 0...+5 V $U_{CC}/2 \pm 10 V$
Setting range of ramp functions	0,05...3 s
Dither frequency	60 / 90 Hz
Dither amplitude	0...30 %
Enclosure type	IP 20
Operating ambient temperature	-20 °C...+50 °C
External dimensions	40 x 79 x 85,5 mm
Attachment	On a strip 35,7x7,5 mm to DIN 50 022
Weight	125 g

Design Models

Front panel of the one-solenoid version

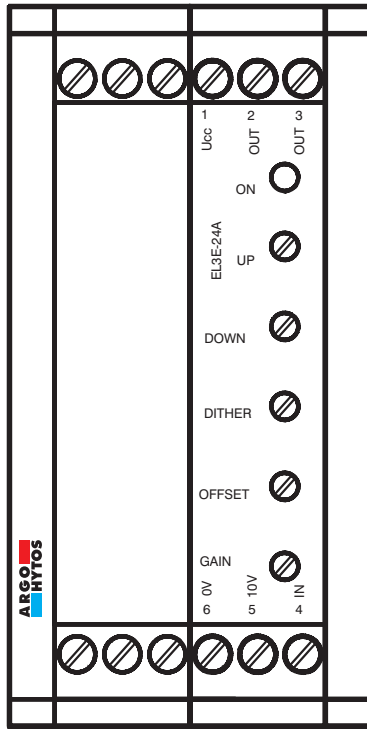

Front panel of the two-solenoid version

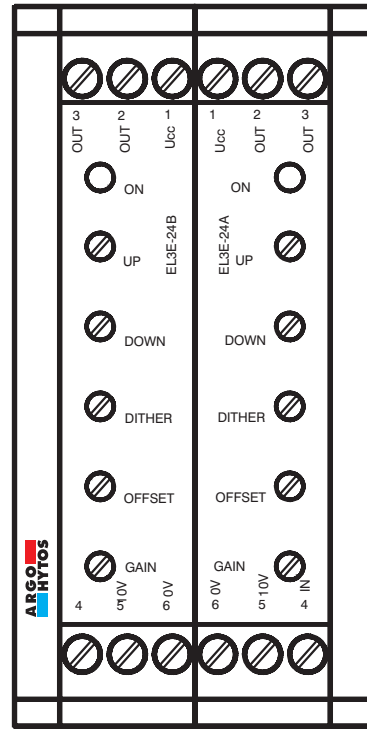

The external electronics EL3E is built into a standard plastic box of dimensions 85,5x79x40mm enabling the grouping on a strip 35,7x7,5 mm and providing the IP 20 electric enclosure. Situated on the front panel are the trims for setting the individual parameters of the electronics and a control LED signaling the presence of the power supply as well as the connection of the electronics output to the solenoid coil of the directional valve controlled.

Two models of the electronics with one or two solenoids are available. The models differ in the inner electric circuitry and in arrangement of the setting elements situated on the front panel as well as in wiring the terminal strips.

6

Electronics for Controlling the Directional Valves with Two Solenoids

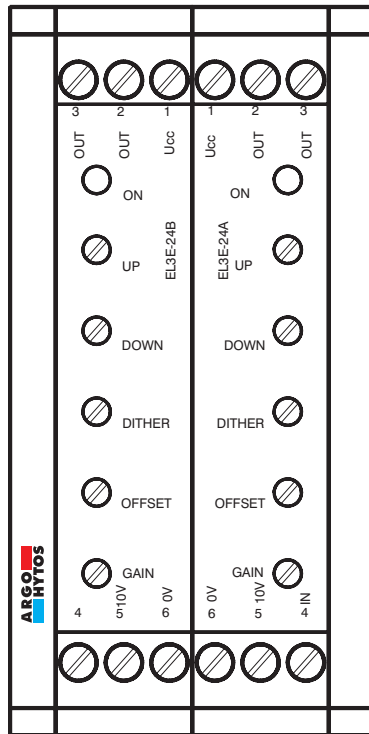

Wiring of connection clamps

Clamp	Description	
	Card MASTER EL3E-XXA	Card SLAVE EL3E-XXB
1	+U _{CC} 24 V (12 V)*	+U _{CC} 24 V (12 V)*
2	Output to the solenoid coil	Output to the solenoid coil
3		
4	Control signal input	-
5	Output of the stabilized voltage +10V/100mA	Output of the stabilized voltage +10V/100mA
	(+5V/100mA)*	(+5V/100mA)*
6	0 V	0 V

*Values in parenthesis are valid for the supply voltage 12 V

The electronics for directional valves with two solenoids consists of two identical electronic cards mutually interconnected. The card designated at its specification end with character A (EL3E-xxA) works as the so-called MASTER; the other card designated with character B (EL3E-xxB) works as the so-called SLAVE. The distinction of the cards is necessary because of the different setting of the changeover switches on both cards serving the configuration of the selected operational parameters, such as the type of the control signal and the dither frequency.

Electronic for Controlling the Proportional Valves with One Solenoid

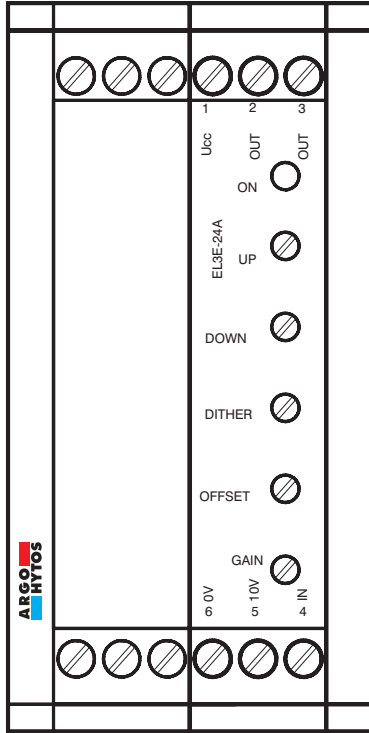

Wiring of connection clamps

Clamp	Description
	Card MASTER EL3E-XXA
1	+U _{CC} 24 V (12 V)*
2	Output to the solenoid coil
3	
4	Control signal input
5	Output of the stabilized voltage +10V/100mA (+5V/100mA)*
6	0 V

*Values in parenthesis are valid for the supply voltage 12 V

The electronics for controlling the proportional directional valves with one solenoid is built into a box with dimensions corresponding with the previous configuration, but only a part of the electronic is fitted with components. The electric wiring of the clamps is identical with the arrangement of the MASTER card in the previous two-magnet configuration.

6

Block Diagram

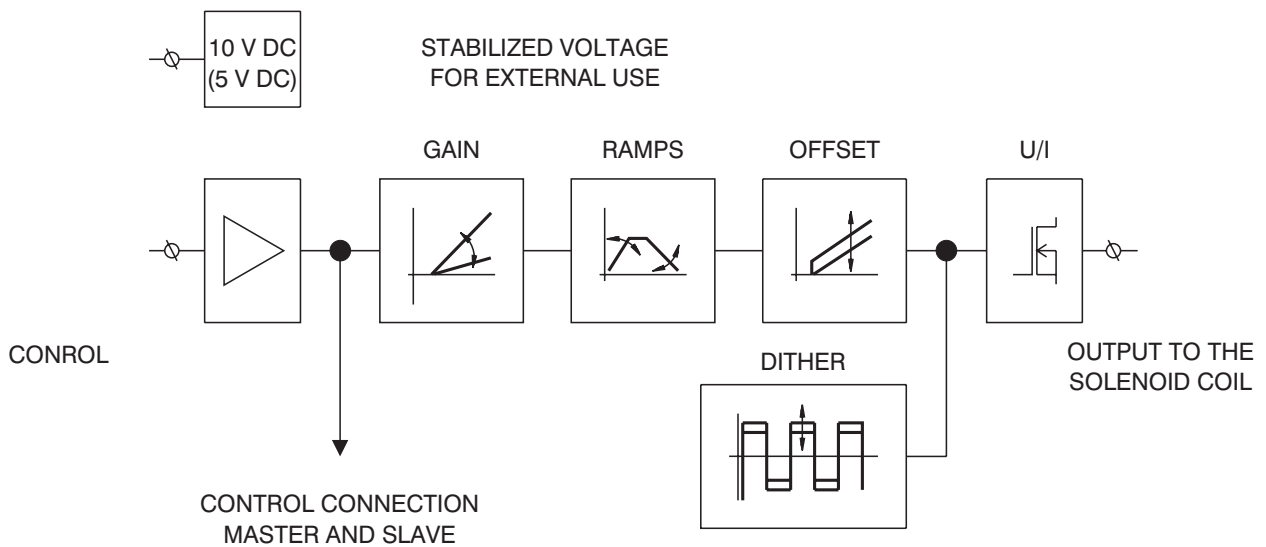

Adjustment of Offset, Gain Parameters

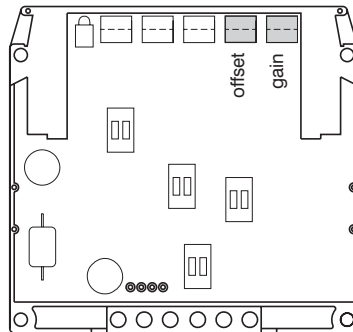
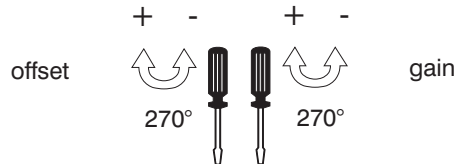
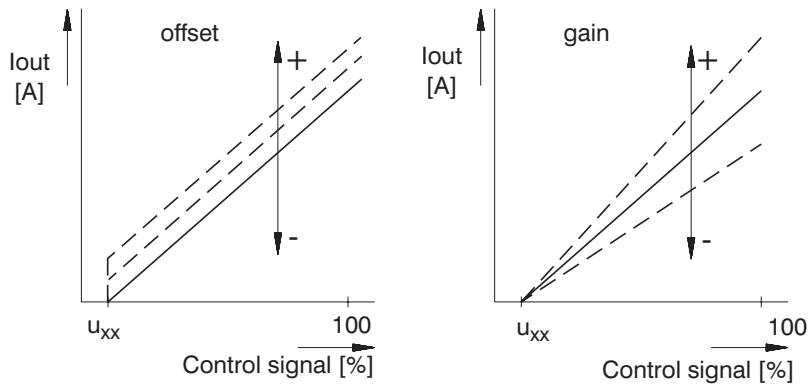

Nominal supply voltage of electronics [V]	Area insensible to control signal u_{xx} [%]
12	1 ... 3
24	0.5 ... 2

6

Ramp Adjustment (up,down)

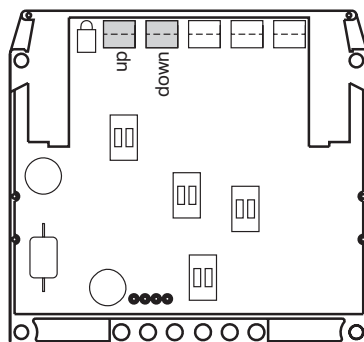
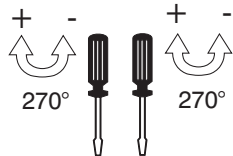
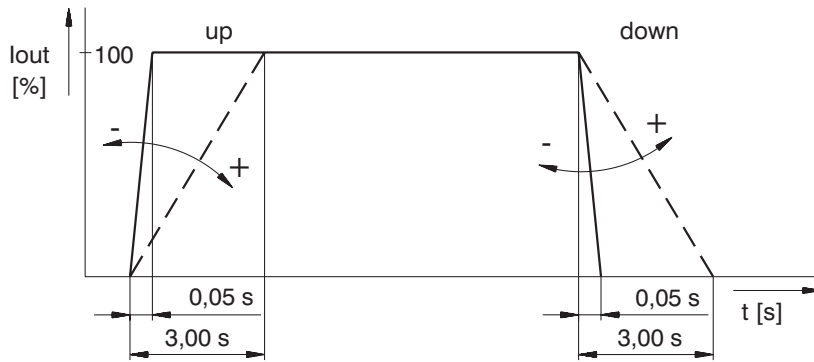

Dither Adjustment

Limit Coil Exciting Current of Proportional Directional Valves ARGO-HYTOS

Valve nominal size	Nominal supply voltage			
	12 V		24 V	
	Coil type	I_{lim} [A]*	Coil type	I_{lim} [A]*
NG04	16186100	1,7	16186200	0,8
NG06	16187500	1,6	16186800	1,0
NG10	16195800	1,9	16196200	1,1

*for load factor 100 %. Values must not exceed 5 %.

Table of the Switch Configuration for the Control Signal Choices

		PRM2-062				PRM2-063	
		0 ... 5 V	0 ... 10 V (0 ... 5 V)*	0 ... 20 mA	4 ... 20 mA	$U_{cc}/2$ ± 10 V (± 5 V)*	± 10 V (± 5 V)*
MASTER M	SW1						
	SW2						
	SW3						
	SW4	90 Hz			60 Hz		
SLAVE S	SW1						
	SW2						
	SW3						
	SW4	90 Hz			60 Hz		

Designation of the basic manufacture setting.

*Values in parenthesis are valid for the supply voltage 12 V

Configuration of Changeover Switches on the Electronics Card According to the Proportional Valve Model and the Control Signal Type Used

The null potential of the control signal must be the same as the null potential of the supply voltage

Proportional directional valve with one solenoid, control signal 0...10V (0...5V)* or controlling by an external potentiometer $R > 1k\Omega$

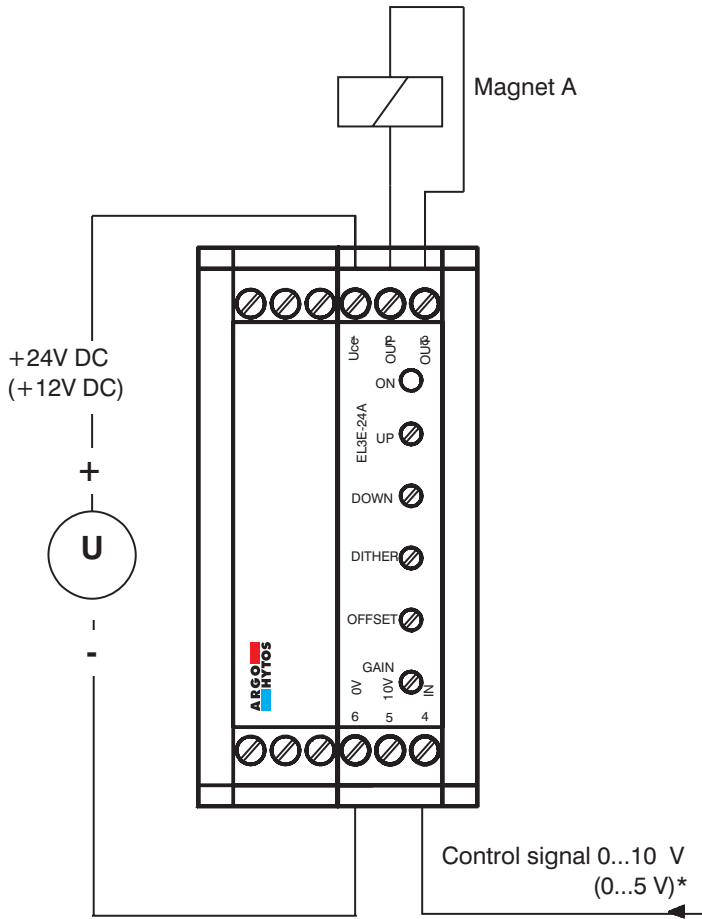

MASTER card for solenoid A

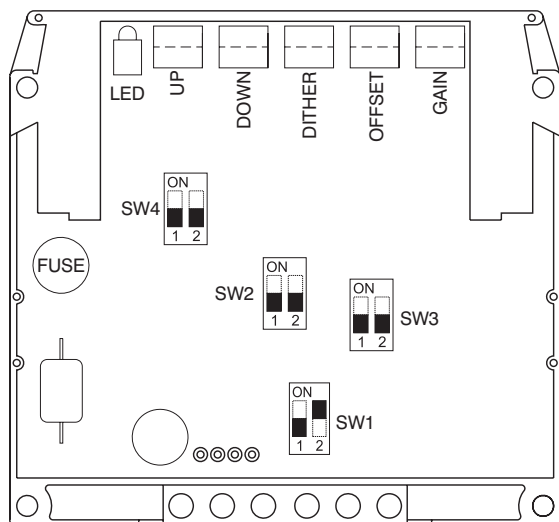
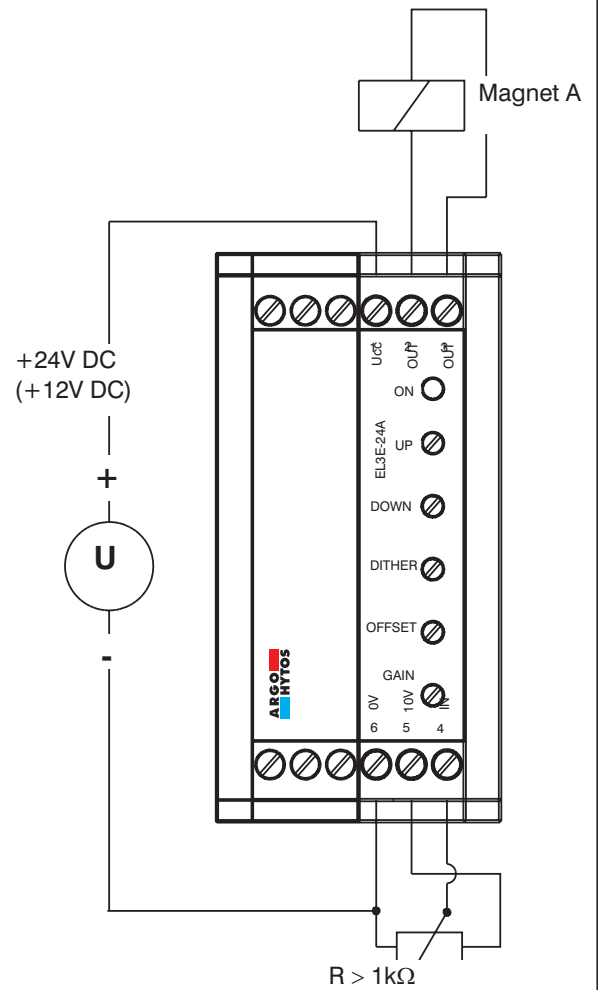

- SW1 - Control signal choice
- SW2 - Control signal choice
- SW3 - Control signal choice
- SW4 - Dither frequency

6

Proportional directional valve with one solenoid, control signal 0..5V (external)

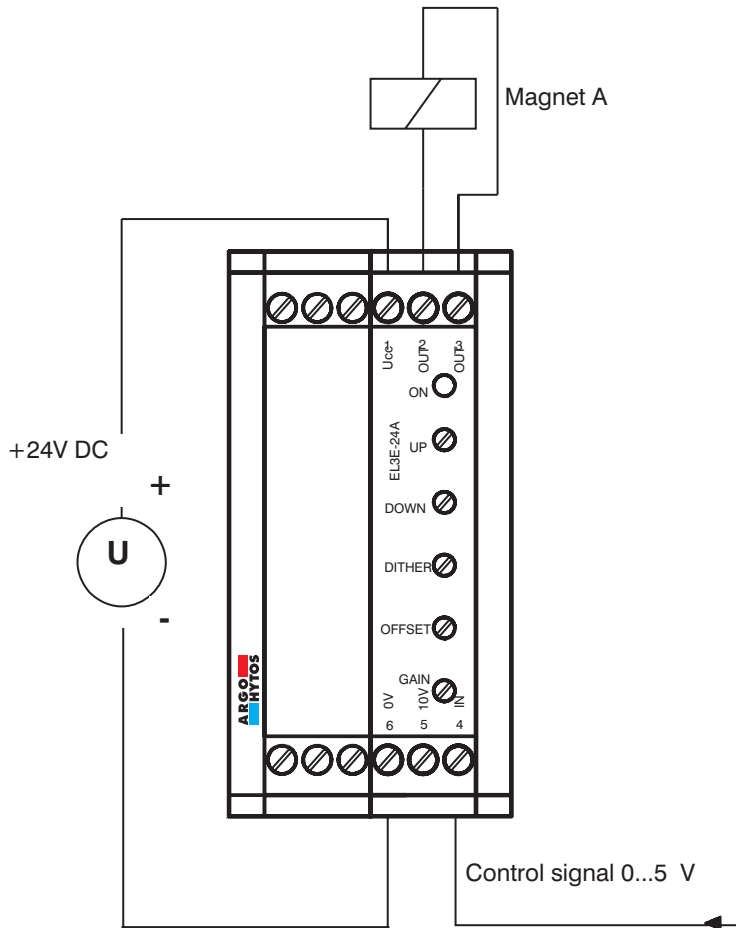

MASTER card for solenoid A

- SW1 - Control signal choice
- SW2 - Control signal choice
- SW3 - Control signal choice
- SW4 - Dither frequency

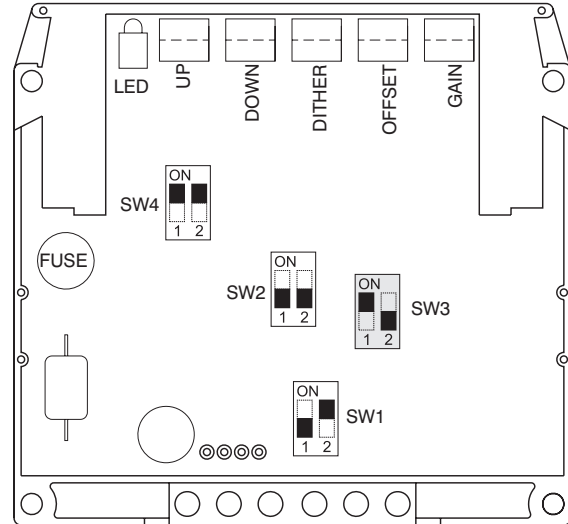

6

Proportional directional valve with one solenoid, control signal 0...20mA

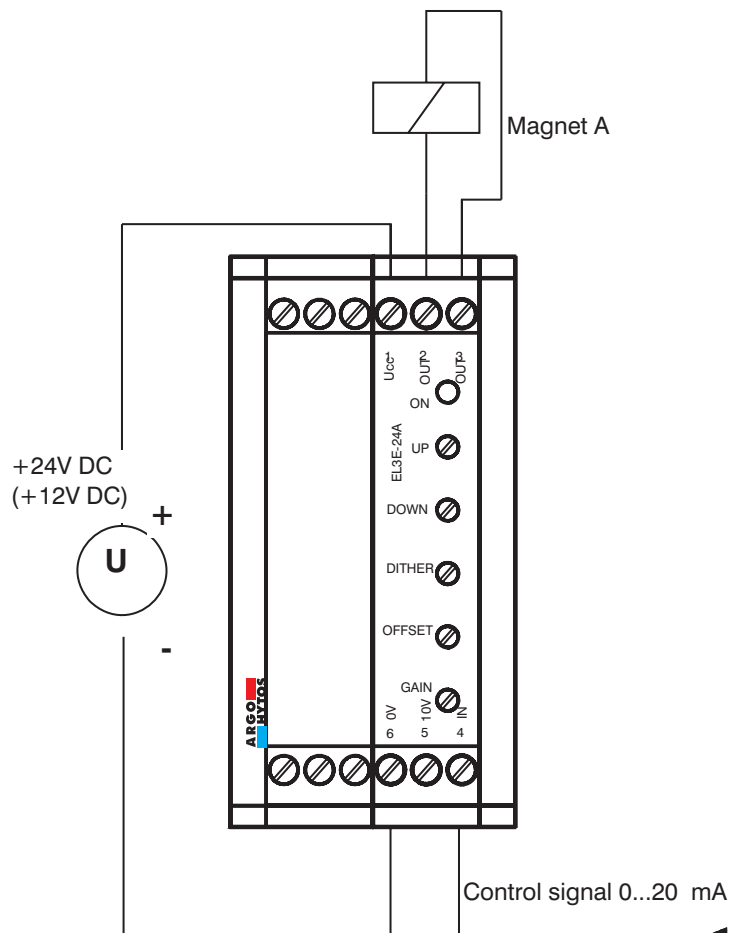

MASTER card for solenoid A

- SW1 - Control signal choice
- SW2 - Control signal choice
- SW3 - Control signal choice
- SW4 - Dither frequency

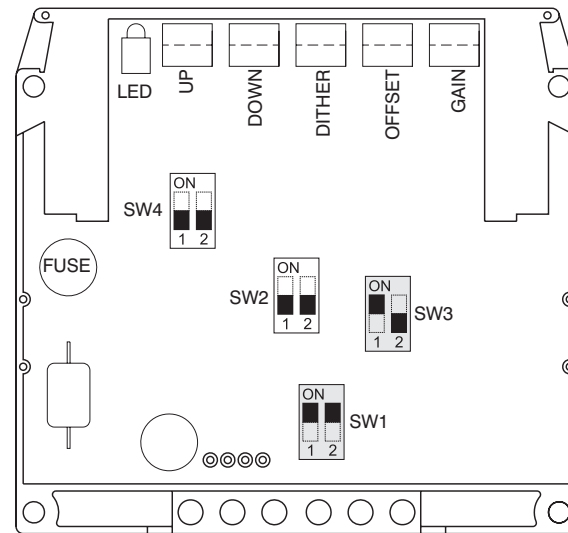

Proportional directional valve with one solenoid, control signal 4...20mA

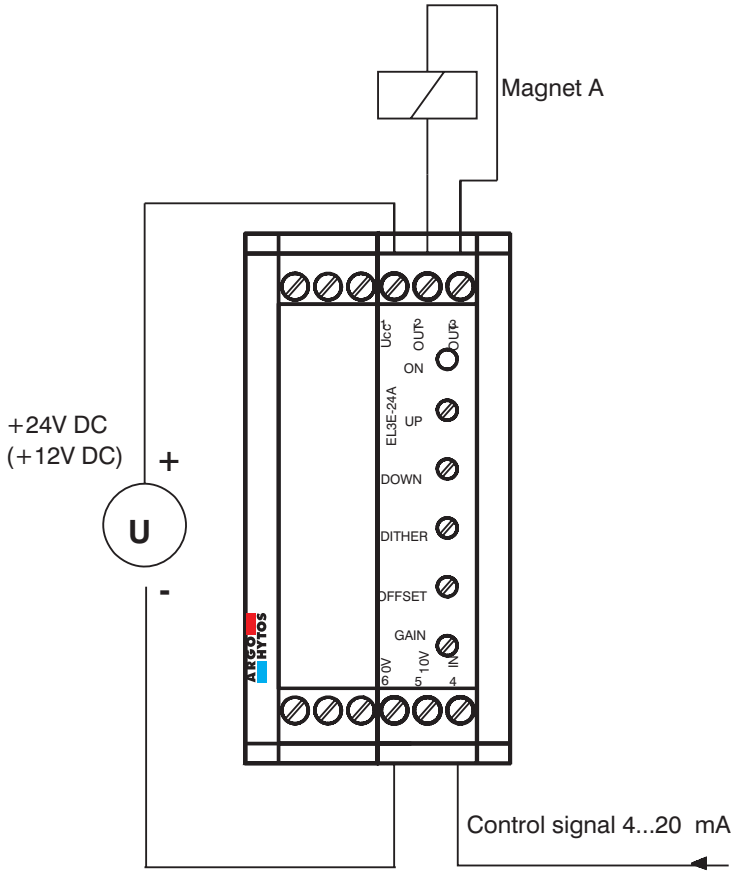

MASTER card for solenoid A

- SW1 - Control signal choice
- SW2 - Control signal choice
- SW3 - Control signal choice
- SW4 - Dither frequency

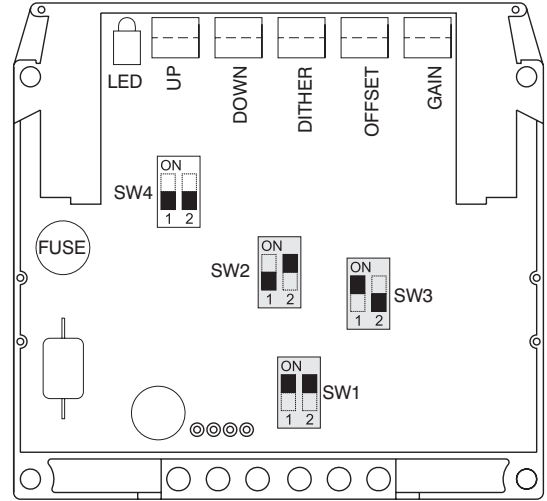

Proportional directional valve with two solenoids, control signal ±10V (±5V)*

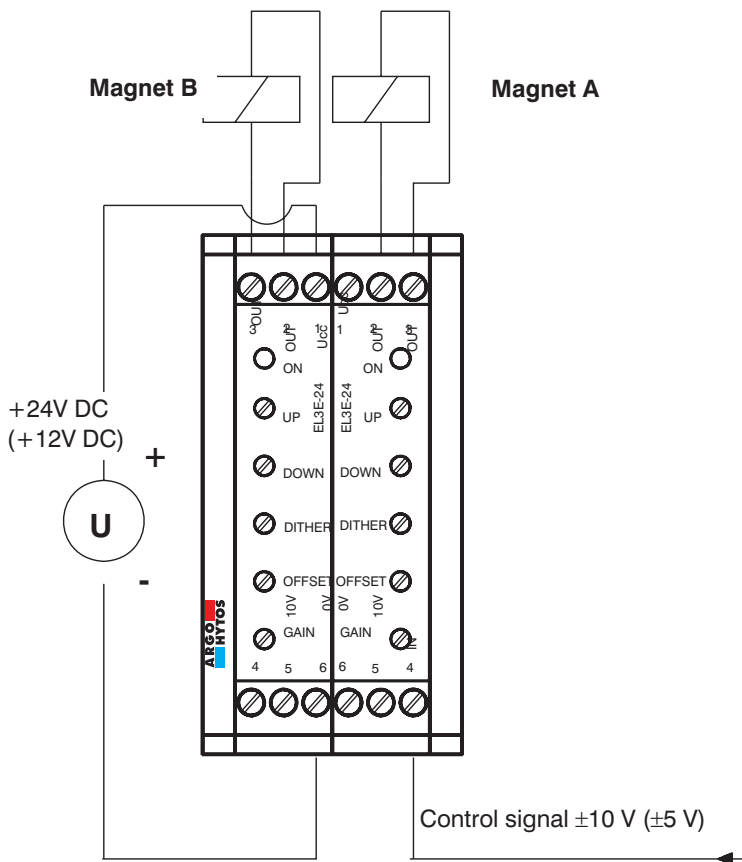

MASTER card for solenoid A

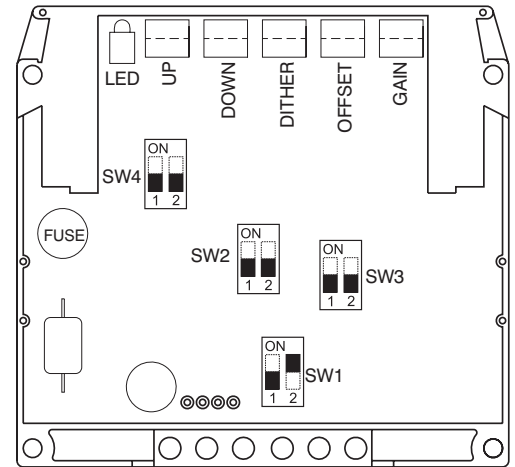

SLAVE card for solenoid B

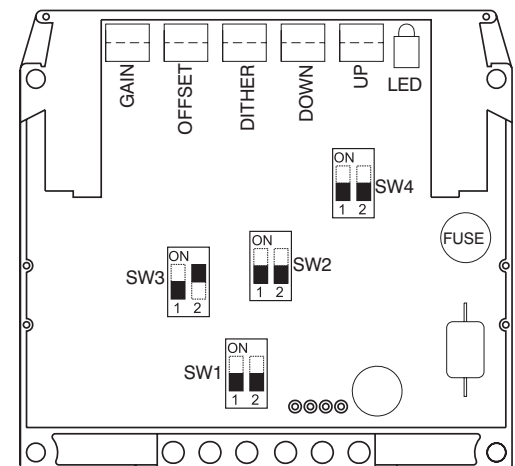

- SW1 - Control signal choice
- SW2 - Control signal choice
- SW3 - Control signal choice
- SW4 - Dither frequency

6

Proportional directional valve with two solenoids, control signal $U_{cc}/2 \pm 10V$ ($U_{cc}/2 \pm 5V$)* with an external potentiometer $R > 1k\Omega$

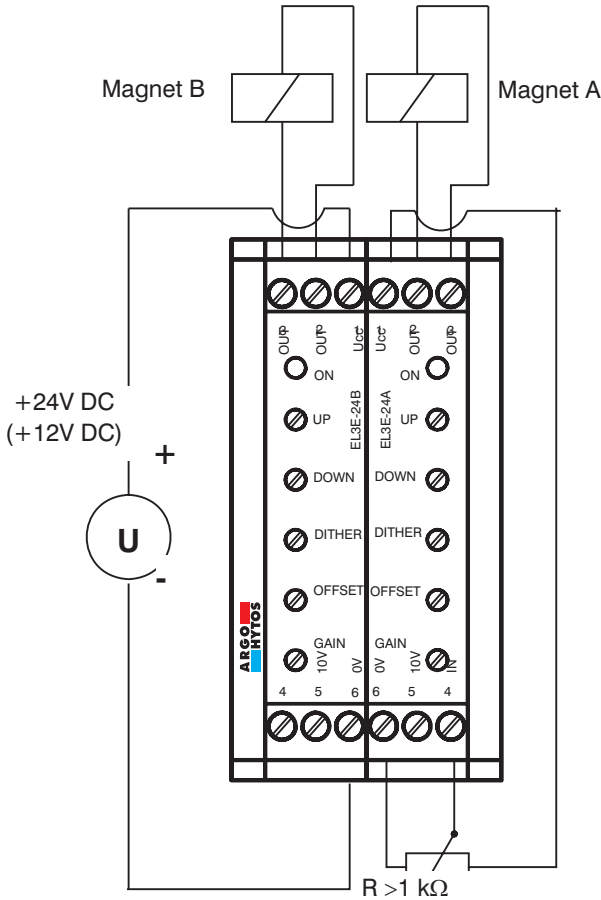

MASTER card for solenoid A

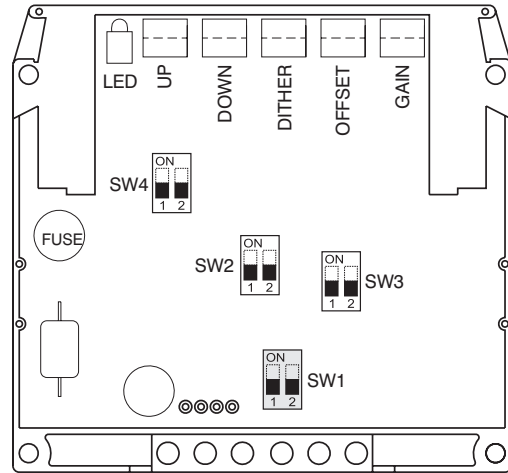

SLAVE card for solenoid B

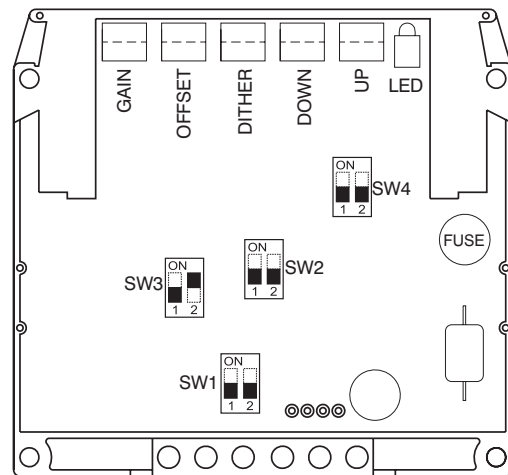

- SW1 - Control signal choice
- SW2 - Control signal choice
- SW3 - Control signal choice
- SW4 - Dither frequency

*Values in parenthesis are valid for the supply voltage 12 V

Caution!

- The packing foil is recyclable.
- The technical information regarding the product presented in this catalogue is for descriptive purposes only. It should not be construed in any case as a guaranteed representation of the product properties in the sense of the law.

ARGO-HYTOS s.r.o. CZ - 543 15 Vrchlaví
 Tel.: +420-499-403111, Fax: +420-499-403421
 E-mail: sales.cz@argo-hytos.com
 www.argo-hytos.com

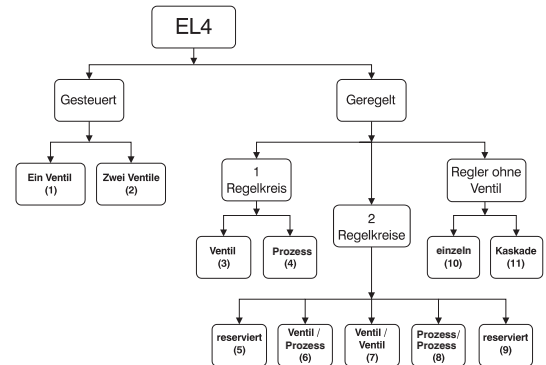
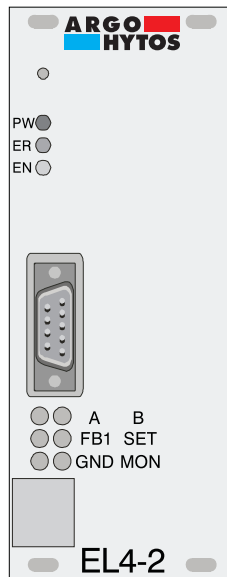

General Applications

The amplifier card EL4 is used for:

- With or without electrical feedback transducers:
 - proportional directional valves direct and pilot operated
 - proportional flow control valves
 - proportional pressure reducing valves
 - proportional pressure regulating valves
 - cartridge valves
 - servo valves with torque motors
- Controlling of hydraulic motors, installations and systems, e.g.:
 - position
 - speed
 - pressure
- revolutions per minute
- torque
- power etc.
- Volume flow control and pressure control of pumps (if the occasion arrives: limitation in weight, controlling valve spool position)
- Controlling of different process values:
 - P/Q controlling
 - pump controlling
 - controlling of pressures
 - controlling of pilot- and main stage
 - cascade controlling of components etc.

Features

- Fully digitized amplifier and controller with the advantage of:
 - no on-board potentiometer
 - no jumpers settings required
 - digital setting and display of all parameters
 - user safety when programming
 - no potentiometer adjustment for measurement of solenoid current
- Flexible and reliable system:
 - use of a modern 16 Bit μ C
 - high power reserve
 - hardware and software extensions available following client's needs (e.g. bus interface, special output stages like H-bridges for servo valves or direct current motors, optional RAM on request)
 - easy software update by use of a Flash-EPROM; adaptations and extensions can be made without change to EPROM (download from PC via RS232)
- high reliability and safety through the use of a hardware watch-dog and reset module
- variable settings for magnetic systems and sensor signals making high flexibility possible
- Functional use of the interface (partly still in development):
 - change of selected parameters "on-the-fly" without interference or interrupting the controller
 - analyzation of system performance through selection of display parameters with the PC
 - a monitoring program allows direct access to amplifier with the use of external system controllers (e.g. programmable logic controllers / PLC)
 - in development: accessing different amplifiers from a PC or a controller by addressing them (using option RS485) and sending data from amplifier to amplifier (copy parameter settings)

Ordering Code

EL4- - - - **S000**

Amplifier card

Board Version

no display **2**
with display **6**

Operation mode

one valve, open loop (2 solenoids) **01**
two valves, open loop (1 solenoid each) **02**
one valve (spool position feedback), (2 solenoids) **03**
one process control loop system (2 solenoids) **04**
reserved **05**
one valve with one spool and one process control loop system (2 solenoids) **06**
two valves with spool position feedback each (1 solenoid each) **07**
two valves with 1 process control loop each (2 solenoids) **08**
reserved **09**
single process controller without valve **10**
cascade controller without valve **11**

Specific options

Solenoid type

004 size 04
006 size 06
010 size 10

6

Technical Data

Parameters	Range, characteristics
Supply voltage	DC (12) 18 ... 30 V, residual ripple < 10 %, (12 V on request)
Solenoid systems selection	0.8 A / 1.1A / 1.3 A / 1.6 A / 2.4 A / 2.7 A / 3.5 A (others on request)
Power input	Max. 50 VA
Applicable fuse (quick)	3.15 A
Auxiliary voltage	± 10 V, max. load 10 mA.
Control voltage for external recallable set point	24 V ± 10 %, residual ripple ≤ 10 % current input ≤ 20 mA each
Ambient temperature	32 °F ... 122 °F (0 °C ... 50 °C) (other range on request)
Storage temperature	-4 °F ... 140 °F (- 20 °C ... 60 °C)
Plug connection	DIN 41 612, 48 pol. form F gold plated
EMC	
Protection	Burst on wires as per EN 61000-4-4 HF-Field as per EN 61000-4-3 ESD as per EN 61000-4-2
Emissions	Emissions depending on power as per EN 50011 Radiated emissions as per EN 55011
Dimensions	
Front panel/ PCB	1.988 x 5.055 in. (50.5 x 128.4 mm); 10 TE / 3 HE / 3.937 x 6.299 in. (100 x 160 mm) Euro format

Technical Data	
Parameters	Range, characteristics
Input signals	
Analogue set values	1 input, differential 14 Bit resolution, 0 ... ± 10 V 1 input, single ended 14 Bit resolution, 0 ... ± 10 V 1 input, single ended 14 Bit resolution, 0 or 4 ... 20 mA (R = 250 Ohm)
Analogue feedback (sensor input)	1 input, 14 Bit resolution, 0 ... ± 12 V, 0 ... 20 mA / 4 ... 20 mA, Offset: 3 ... 10 V, Gain: ca. 0 ... 14 (R=100 Ohm) 1 input, 14 Bit resolution, 0 ... ± 10 V
Digital inputs	8 inputs, voltage level 0 V / 24 V, 10 mA (Set point 1 ... 4, ENABLE, RAMP, SIGN +, SIGN -)
Output signals	
Solenoid current	2 output stages for up to 3.5 A; with over-energization and quick de-energization
Analog output	1 output, 12 Bit resolution, 0 ... ± 10 V; for controlling of subsequent electronic
Monitor output	1 output, 12 Bit resolution, 0 ... ± 10 V; for monitoring of internal values
Digital outputs	2 outputs, voltage level 0 V / 24 V, 10 mA (Error, Comparator)
Test jacks	Solenoid current, sensor 1, set value, Monitor and GND
Auxiliary voltage	± 10 V, max. load 10 mA
Optional I/O signals	
	3 in or outputs, output level 24 V, input level 5 V or 24 V (5 V level for incremental sensors on request)
Interface	
	RS232 or RS485 with 9-pol Sub-D connector at front panel; RS485 also at back connector available (RS485 functions in preparation)
Display and operation	
Only at EL4-6	4 digit display, 6 buttons (up, down, left, right, enter and Esc) Status-LED's: PW (Power), ER (Error), EN (Enable), SP1 ... SP4 (S1.01 ... S1.04), RP0 (Ramp = 0), IO1 ... IO3
Only at EL4-2	Status-LED's: PW (Power), ER (Error), EN (Enable)
Frequencies and cycle times	
PWM Frequency	18 kHz
Cycle times	Current controller ca. 0.22 msec, inner closed loop controller ca. 0.22 msec (for valve feedback), external closed loop controller 2 ca. 0.44 msec
Accessories	
Ordering number	Content
23144700	Connecting cable to PC and EL4 - 98.42 in (2.5 m)
23144800	Connecting cable to PC and EL4 - 196.85 in (5 m)
23144600	CD - ROM with software and manual (hd, ha version), connecting cable - 196.85 in (5 m)

Hardware-Block Diagram

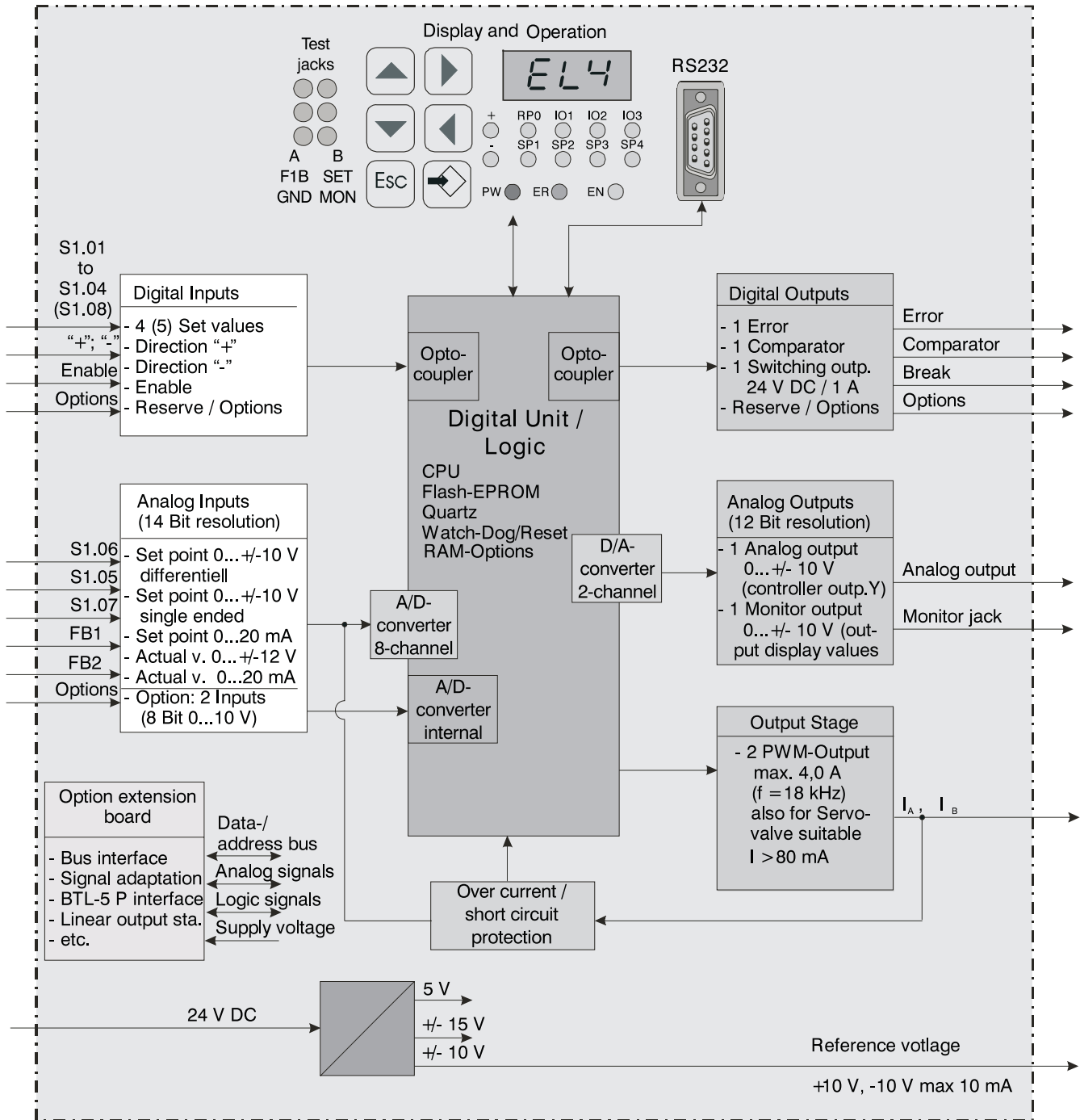

6

Display and Keypad

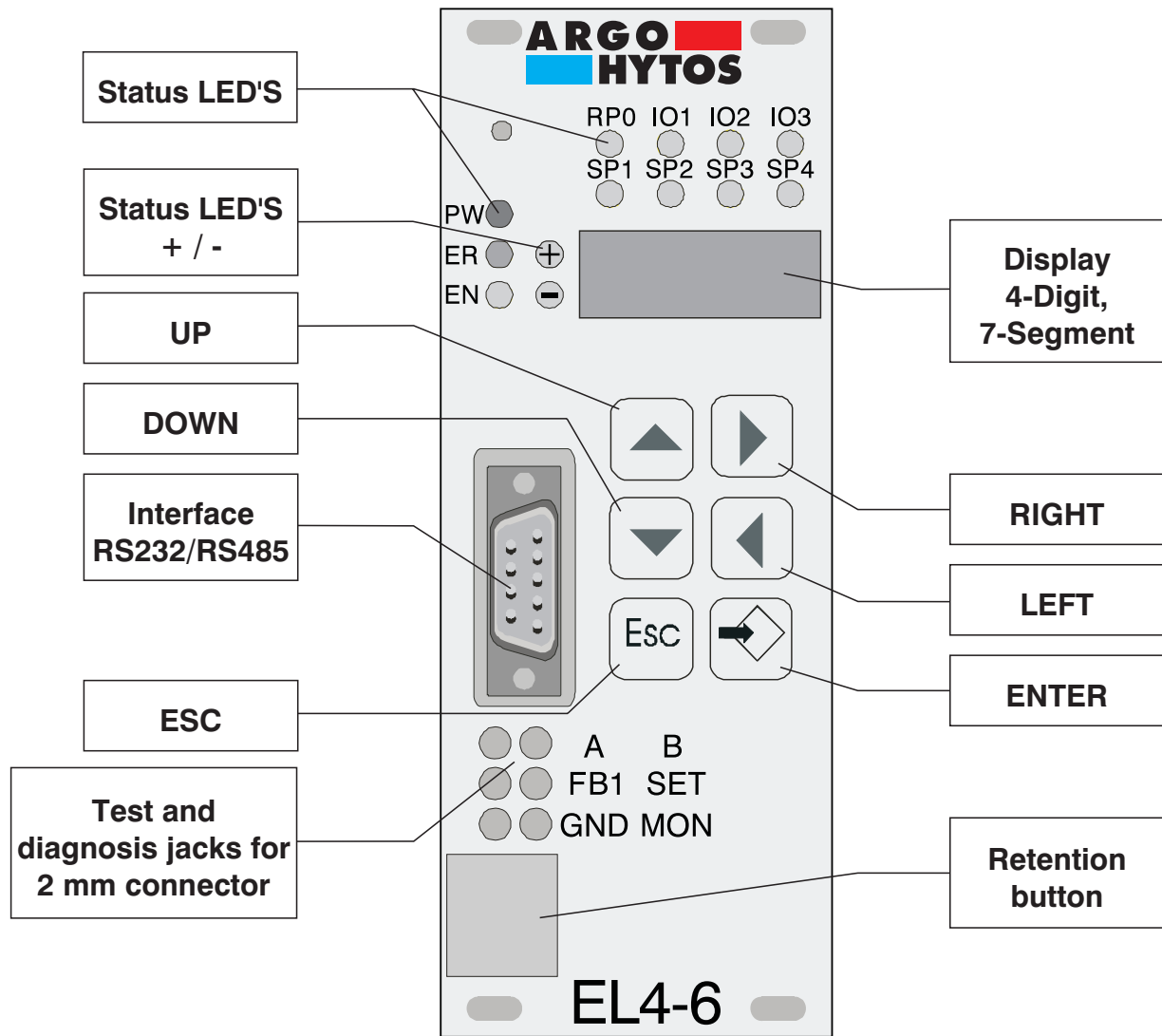

Element	Function
Status LED's	display of status and signals at the digital inputs and outputs
Status LED's + / -	display of set point direction through polarity signs for parameters and measured values
Display	4-digit display of parameters and measured values
Buttons UP, DOWN, LEFT, RIGHT, ESC and ENTER	all operating, programming and saving may be performed with the buttons UP, DOWN, LEFT, RIGHT, ESC and ENTER
Serial interface	RS232/RS485 (optional), trough which programming and accessing parameters via PC or communications to machine, or from amplifier to amplifier
Measuring and test jacks	direct measurement of set point, actual value, solenoid currents and internal values via the monitor output. Use 2 mm sockets (S1.06, FB1, A, B, d1.01 ... d2.13)

6

Diagram of Operation Modes

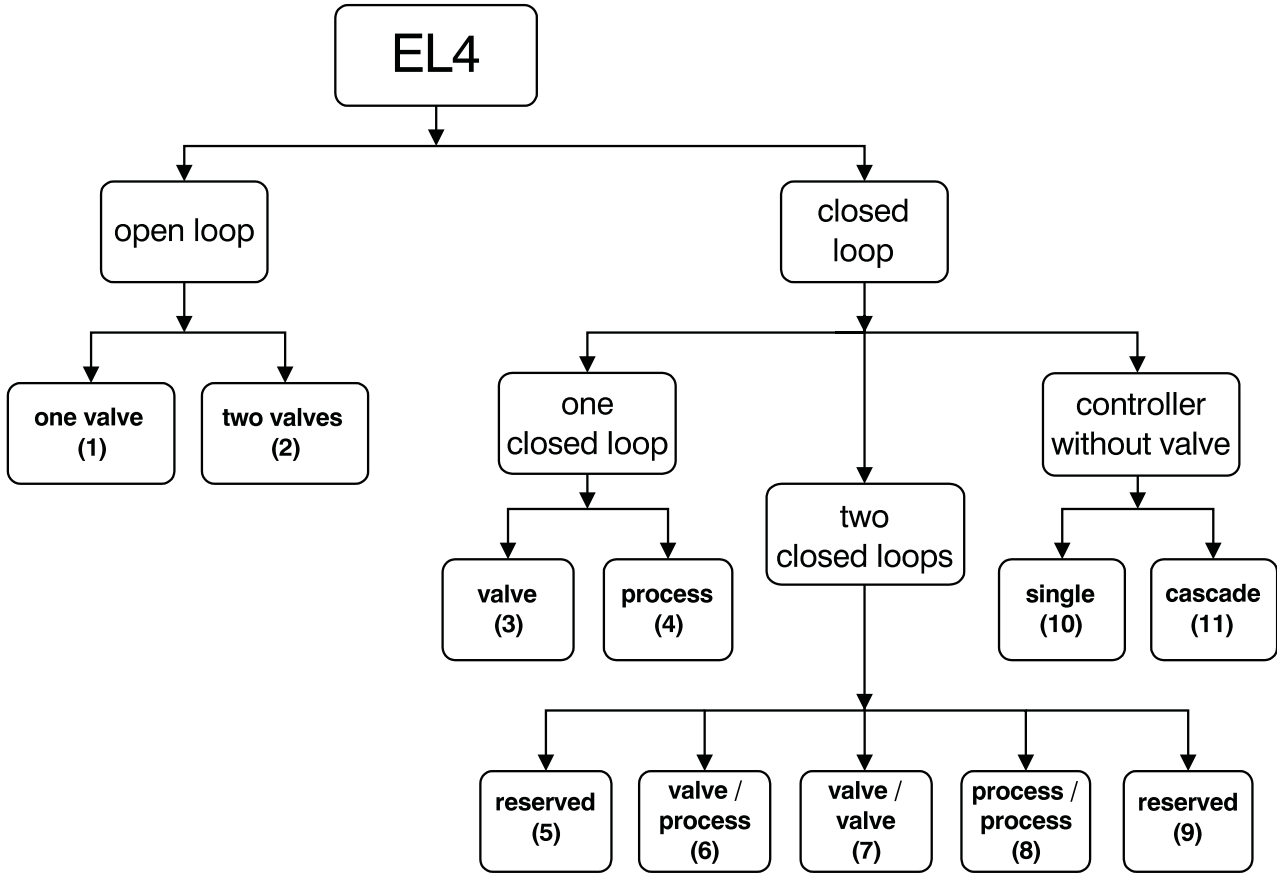

6

Mode	Description
1	Open loop, 1 proportional valve with 2 solenoids without feedback
2	Open loop, 2 proportional valves with 1 solenoid each without feedback
3	Closed loop valve, single, 1 proportional valve with 2 solenoids and feedback of spool position
4	Closed loop process, single, 1 proportional valve with 2 solenoids and feedback of process value (position, velocity, pressure, force, torque etc.)
5	Reserved
6	Closed loop valve and process, double, 1 proportional valve with 2 solenoids and feedback of spool position and additional feedback of process value (cascaded controller)
7	Closed loop valves, double, 2 independent proportional valve with 1 solenoid each and feedback of spool position of each valve
8	Closed loop processes, double, 2 independent proportional valve with 1 solenoid each and feedback of two independent process values (e.g. two pressure control systems)
9	Reserved
10	Controller function without valve, control of 1 process value; provide set value to follow up electronics (e.g. valve with integrated electronics, frequency converter for AC motor etc.)
11	Controller function without valve, control of 2 process values (cascaded controller, e.g. position and velocity controller); provide set value to follow up electronics (e.g. valve with integrated electronics, frequency converter for AC motor etc.)

Software Structure Diagrams

Parameter setting

d *.* : d isplay	A *.* : A uxiliary
S *.* : S et point	C *.* : C ontroller
r *.* : r amps	E ** : E xtended

Mode 1; Open Loop, One Valve

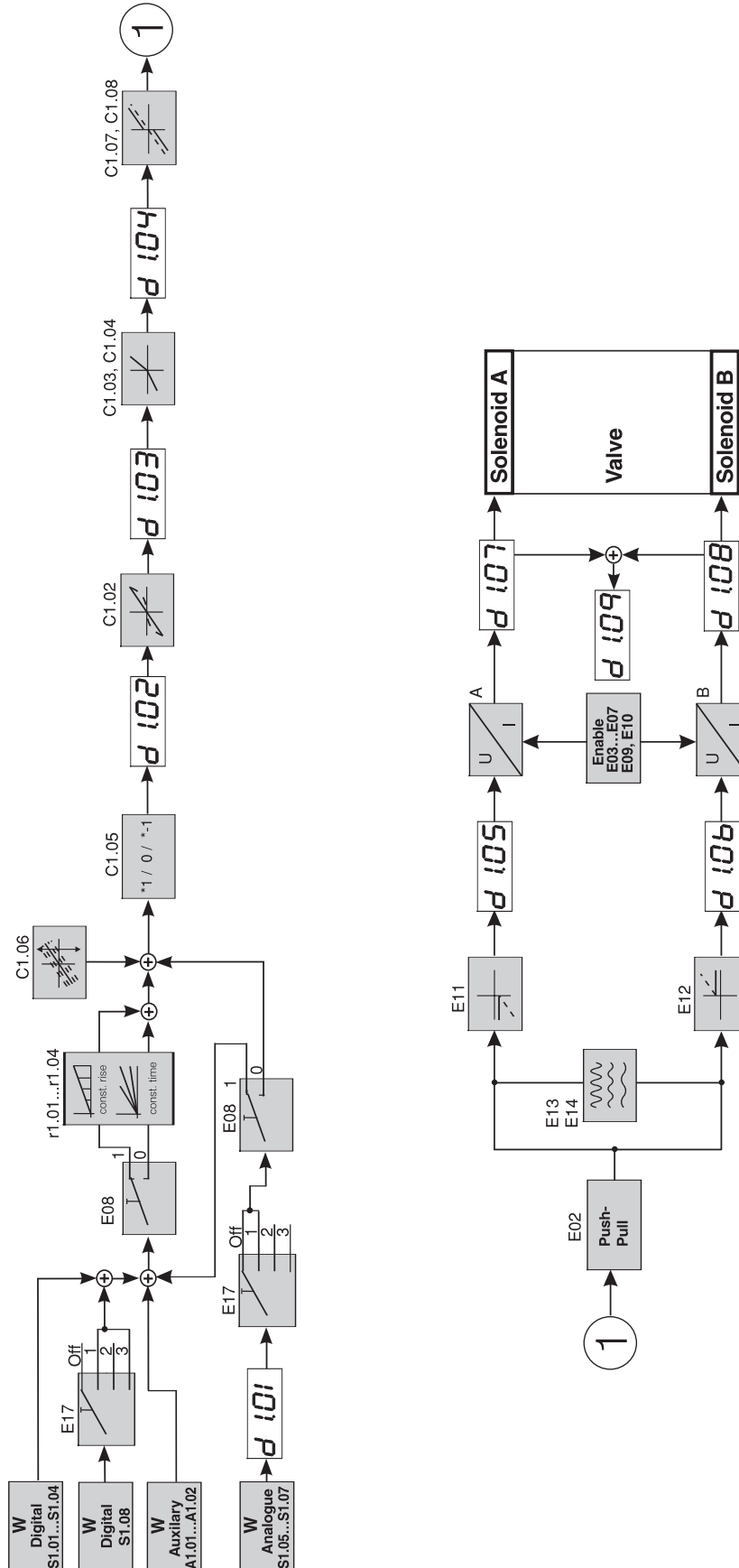

Mode 6, Double Closed Loop, One Spool and One Process Control Loop System

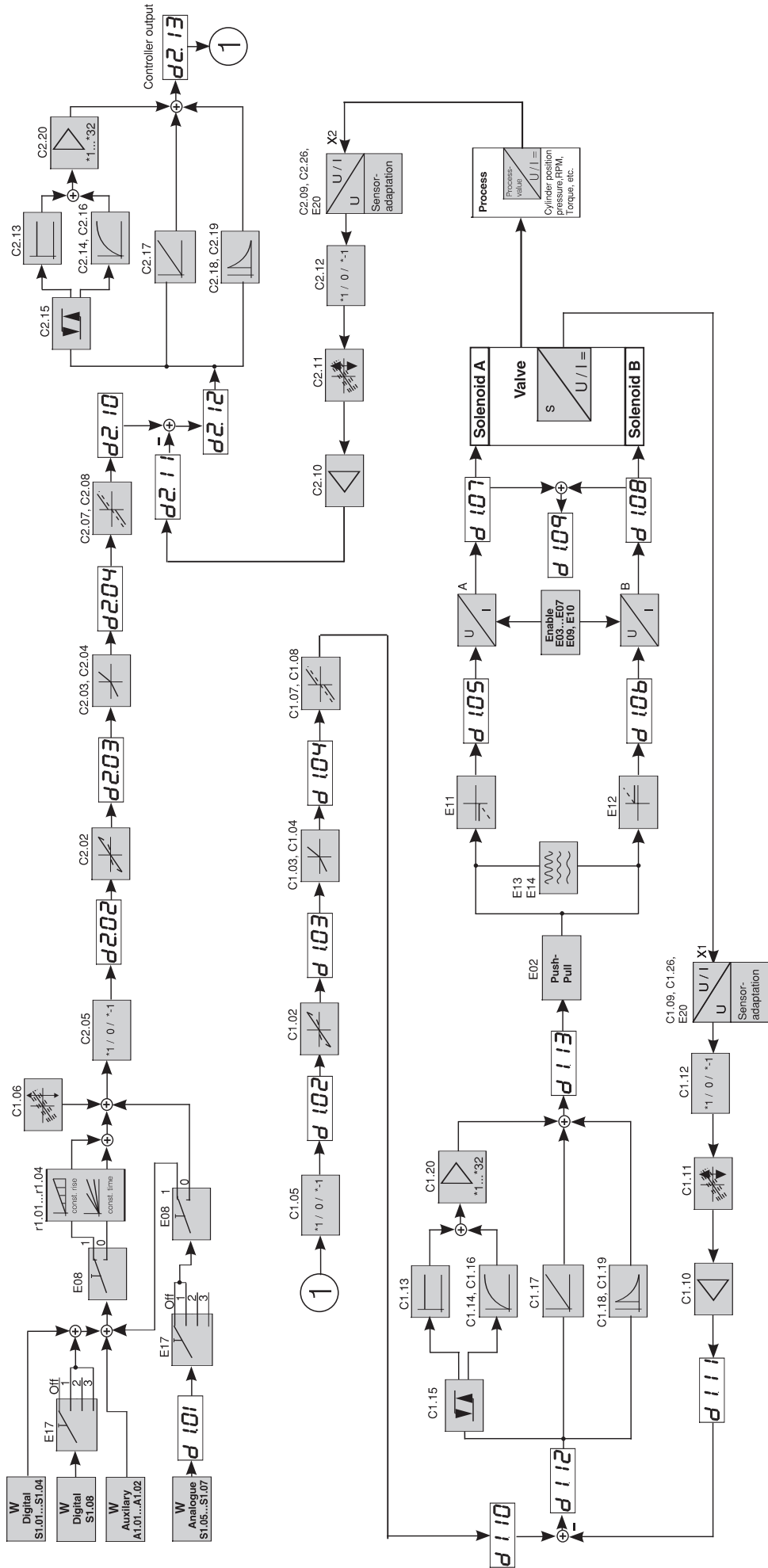

Caution!

- The packing foil is recyclable.
- The technical information regarding the product presented in this catalogue is for descriptive purposes only. It should not be construed in any case as a guaranteed representation of the product properties in the sense of the law.

ARGO-HYTOS s.r.o. CZ - 543 15 Vrchlabí
Tel.: +420-499-403111, Fax: +420-499-403421
E-mail: sales.cz@argo-hytos.com
www.argo-hytos.com

- Modular design for vertical stacking assemblies
- Build-in load sensing shuttle valve
- Installation dimensions to ISO 4401:1994

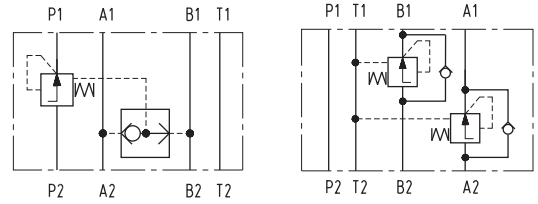

Functional Description

2 way pressure compensator for meter-in application

The 2 way pressure compensators in meter-in application will maintain a constant pressure difference across the metering edge of the proportional directional valve. In this case, the pressure variations due to loading changes, as well as pump pressure changes are compensated so any increase in pump pressure does not affect the flow. The meter-in compensators may only be used with positive load direction.

Valves TV2-042/M are directly operated 2 way pressure compensators in sandwich plate design. They are designated for load compensation in channel P.

The main parts of these valves are the housing (1), control spool (2), spring (3) and shuttle valve (4). The spring (3) holds the spool in the open position from P2 to P1, provided that the pressure difference between P1 and A (P1 - B) is less than 10 bar. When the pressure difference exceeds the value of 10 bar, the spool shifts against the spring until the desired pressure difference has been restored.

The pressure signal comes through passage (5) from channel P.

The valve body is phosphated, all other parts are zinc coated.

2 way pressure compensator for meter-out application

In systems with changing load directions, the use of meter-out pressure compensators is required. With respect to the application a valve with pressure compensator installed in one, or in both actuator ports are available.

The pressure compensator is always mounted between the actuator and the proportional directional valve. The valve will maintain the pressure difference between A and T or B and T constant. The flow rate and the flow direction are adjusted by the proportional directional valve. To enable the reverse flow, two by-pass check valves are incorporated into the valve body.

The valve consists of the valve body (1), one or two control spools (2) and poppets of the by-pass check valves (3). If the pump, for example, is connected to port A, the fluid passes to the actuator through a check valve and returns from the actuator through channel B to the proportional directional valve. The pressure difference across the metering edge of the directional valve is maintained at a constant level. This ensures a constant flow rate independent to the load. The pressure difference is controlled by the metering edge (4), its value being determined by spring force (5).

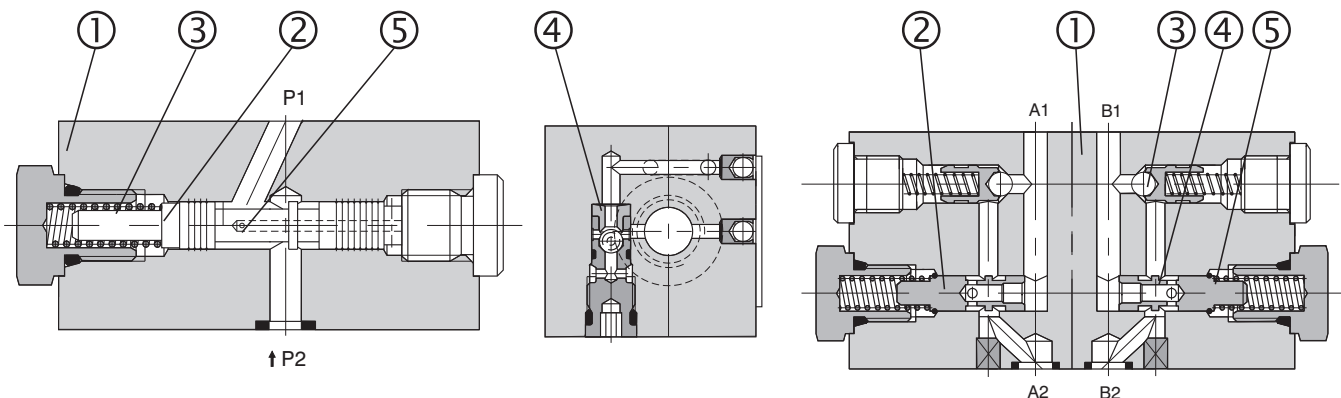

Ordering Code

TV2 - 042/M

Pressure Compensator

Nominal size

2 Way Pressure Compensator

Sandwich plate design

without designation
V

Seals
NBR
FPM (Viton)

A
B
C
D
E
F

Model
Meter-in compensator in channel A
Meter-in compensator in channel B
Meter-in compensator in channels A and B
Meter-out compensator in channels A and B
Meter-out compensator in channel A
Meter-out compensator in channel B

Technical Data

Nominal size	mm	04
Maximum flow	L/min	20
Max. operating pressure	bar	350
Pressure drop on valve Δp	bar	10
Hydraulic fluid	Hydraulic oils of power classes (HL, HLP) to DIN 51524	
Maximum degree of fluid contamination	Class 21/18/15 to ISO 4406	
Weight (Model A,B,C,D,E,F)	kg	0.6
Mounting position	unrestricted	

Functional Symbols

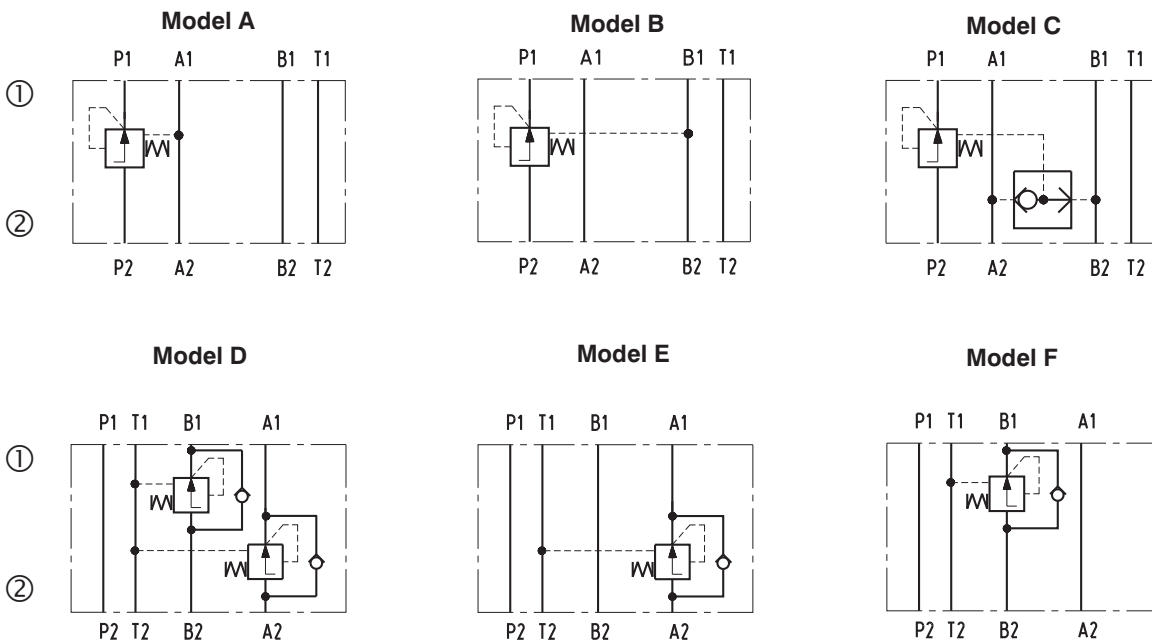

① valve side
② plate side

Typical Applications

TV2-042/MC Meter-in compensator

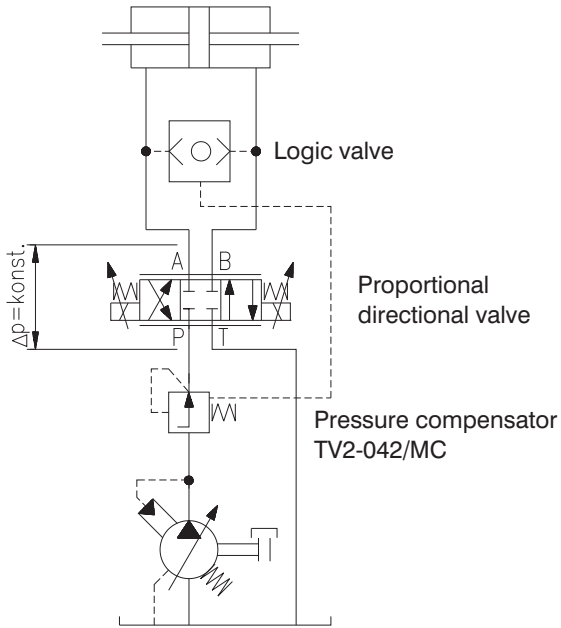

TV2-042/MD Meter-out compensator

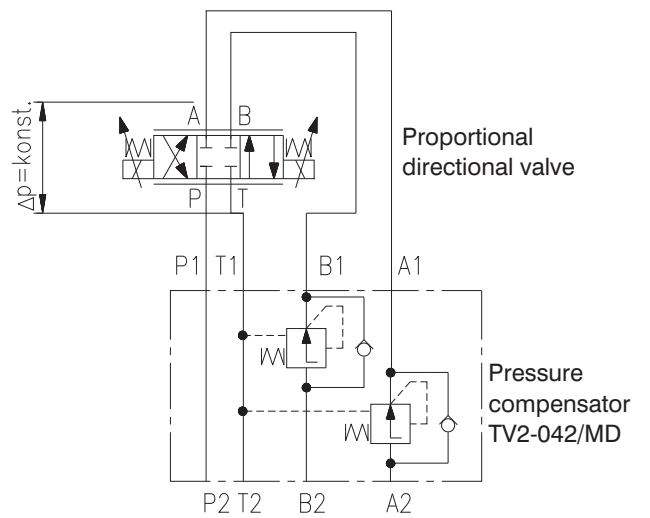

Characteristics

Measured at $v = 32 \text{ mm}^2/\text{s}$

The characteristic of the pressure compensator corresponds to the flow rate of a PRM2-043Z11/12 proportional directional valve. By increasing the flow resistance due to a flow rate increase, also the outside pressure difference has to be increased, in order to ensure the correct control function.

TV2-042/MC Meter-in compensator

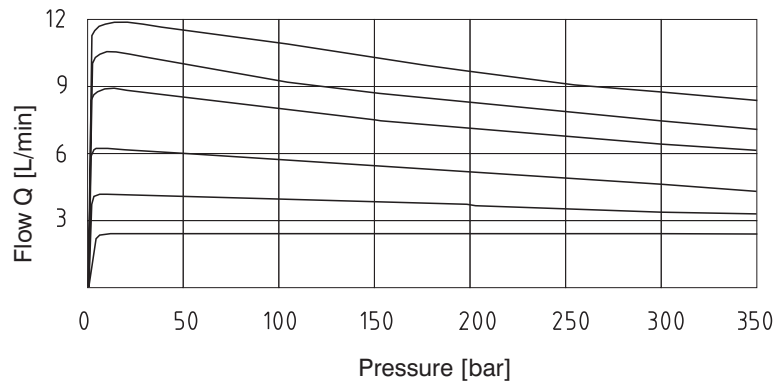

TV2-042/MD Meter-out compensator

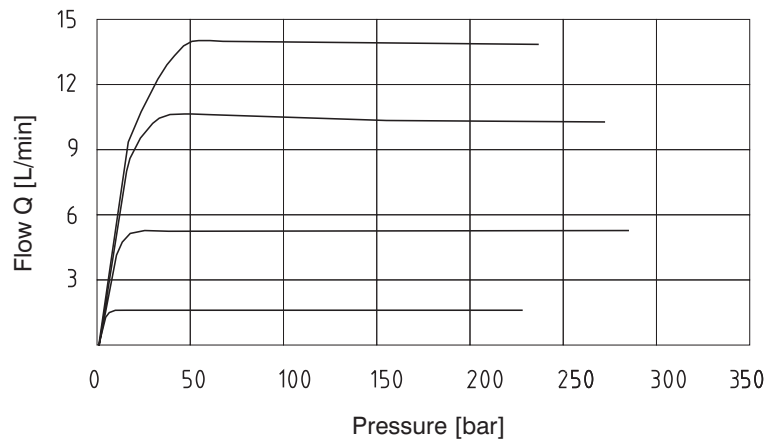

6

Valve Dimensions

Dimensions in millimetres

TV2-042/M Meter-in compensator

- 1 Name plate
- 2 Squarq ring 7.65 x 1.68 (4 pcs.)
- 3 4 mounting holes

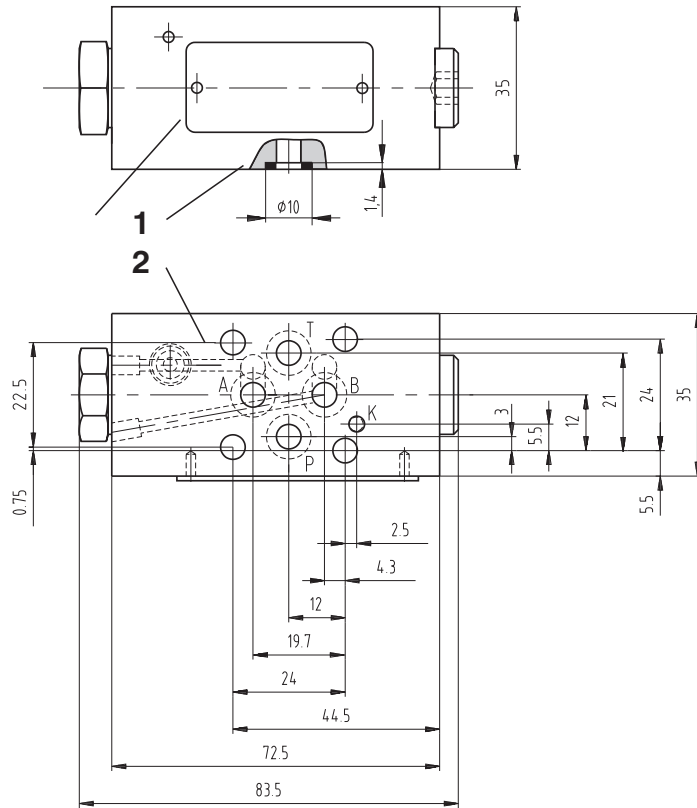

TV2-042/M Meter-out compensator

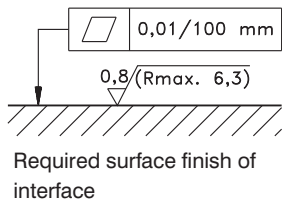
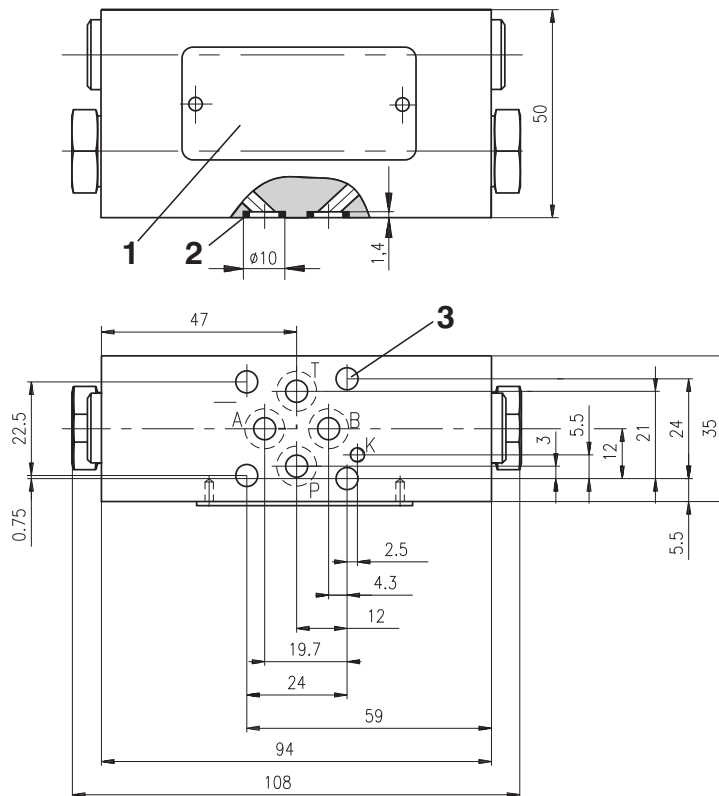

Caution!

- The packing foil is recyclable. The protective plate can be returned to manufacturer.
- The technical information regarding the product presented in this catalogue is for descriptive purposes only. It should not be construed in any case as a guaranteed representation of the product properties in the sense of the law.

ARGO-HYTOS s.r.o. CZ - 543 15 Vrchlaví
 Tel.: +420-499-403 111
 E-mail: info.cz@argo-hytos.com
 www.argo-hytos.com

- Modular design for vertical stacking assemblies
- Build-in load sensing shuttle valve
- Installation dimensions to ISO 4401:1994 and DIN 24 340-A6
- Possibility of LS-Signal through Adapter G1/4/G1/4-ED

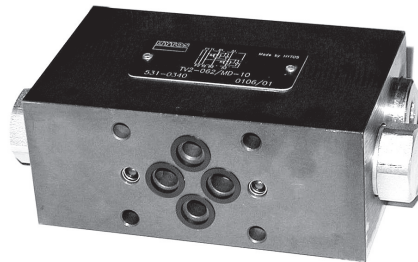
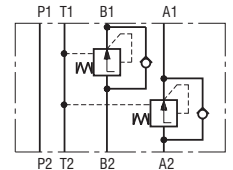
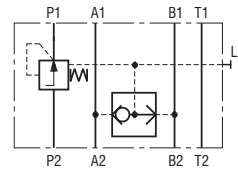

Functional Description

2-Way pressure compensator for meter-in application

The 2-way pressure compensators in meter-in application will maintain a constant pressure difference across the metering edge of the proportional directional valve. In this case, the pressure variations due to loading changes, as well as pump pressure changes are compensated so any increase in pump pressure does not affect the flow. The meter-in compensators may only be used with positive load direction.

Valves TV2-062/M are directly operated 2-way pressure compensators in sandwich plate design. They are designated for load compensation in channel P.

The main parts of these valves are the housing (1), control spool (2), spring (3) and shuttle valve (4). The spring (3) holds the spool in the open position from P2 to P1, provided that the pressure difference between P1 and A (P1 - B) is less than 10 bar (145 PSI). When the pressure difference exceeds the value of 10 bar (145 PSI), the spool shifts against the spring until the desired pressure difference has been restored.

The pressure signal comes through passage (5) from channel P.

The valve body is phosphated, all other parts are zinc coated. Replacement of the steel end plug on the spring side by an adapter with outlet thread G1/4" allows measuring of "LS" signal.

2-Way pressure compensator for meter-out application

In systems with changing load directions, the use of meter-out pressure compensators is required. With respect to the application a valve with pressure compensator installed in one, or in both actuator ports are available.

The pressure compensator is always mounted between the actuator and the proportional directional valve. The valve will maintain the pressure difference between A and T or B and T constant. The flow rate and the flow direction are adjusted by the proportional directional valve. To enable the reverse flow, two by-pass check valves are incorporated into the valve body.

The valve consists of the valve body (6), one or two control spools (7) and poppets of the by-pass check valves (8). If the pump, for example, is connected to port A, the fluid passes to the actuator through a check valve and returns from the actuator through channel B to the proportional directional valve. The pressure difference across the metering edge of the directional valve is maintained at a constant level. This ensures a constant flow rate independent to the load. The pressure difference is controlled by the metering edge (9), its value being determined by spring force (10). A similar valve function develops when the proportional valve ports P and B are connected.

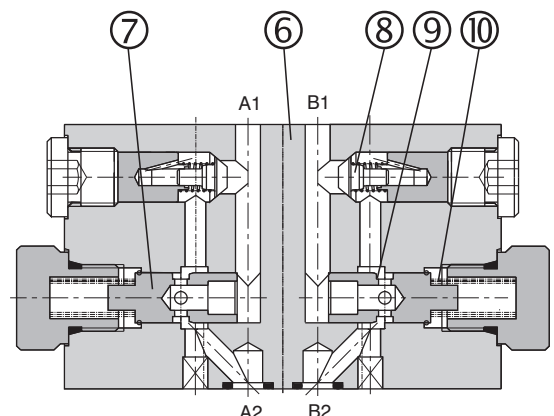
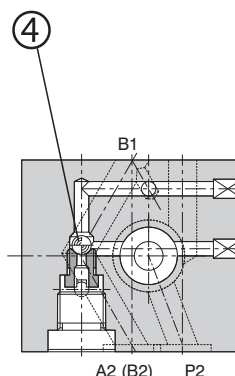
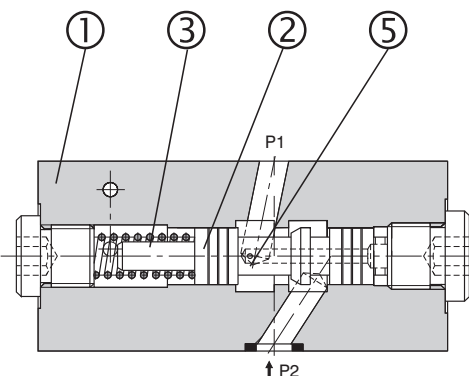

Ordering Code

TV2 - 062/M

Pressure Compensator

without designation
V

Seals
NBR
FPM (Viton)

Valve size

06 (D 03)

2-Way pressure compensator

A
B
C
D
E
F

Model
Meter-in compensator in channel A
Meter-in compensator in channel B
Meter-in compensator in channels A and B
Meter-out compensator in channels A and B
Meter-out compensator in channel A
Meter-out compensator in channel B

Sandwich plate design

Technical Data

Valve size	mm (US)	06 (D 03)
Maximum flow	L/min (GPM)	35 (9.2)
Max. operating pressure	bar (PSI)	350 (5076)
Pressure drop on valve Δp	bar (PSI)	10 (145)
Hydraulic fluid	Hydraulic oils of power classes (HL, HLP) to DIN 51524	
Maximum degree of fluid contamination	Class 21/18/15 to ISO 4406	
Weight (Model A,B,C,D,E,F)	kg (lb)	1.00 (2.2)
Mounting position	unrestricted	

Functional Symbols

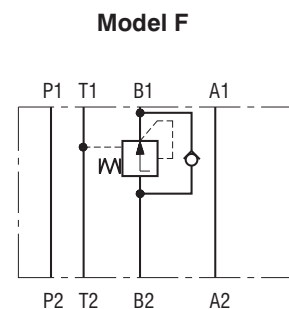
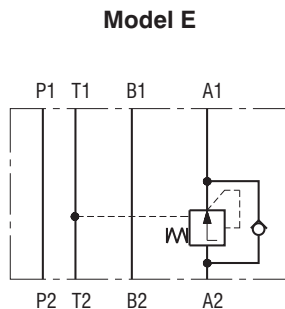
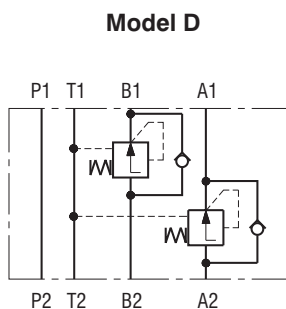
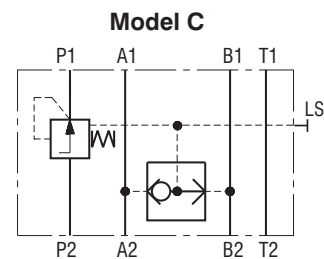
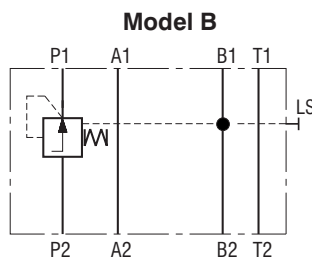
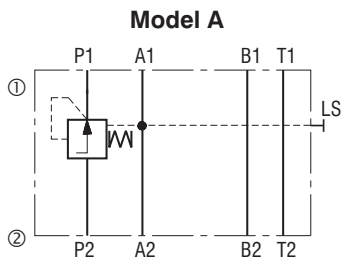

- ① valve side
- ② plate side

Typical Application

TV2-062/MC Meter-in compensator

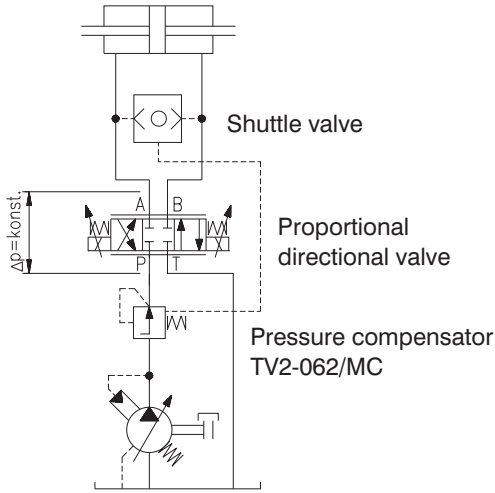

TV2-062/MD Meter-out compensator

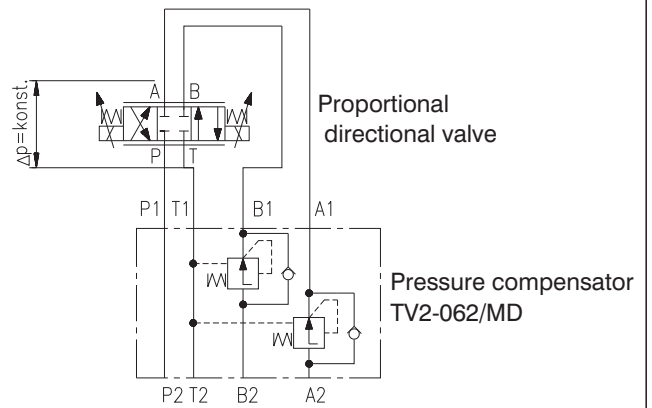

Δp-Q Characteristics

Measured at $v = 32 \text{ mm}^2/\text{s}$ (156 SUS)

The characteristic of the pressure compensator corresponds to the flow rate of a PRM2-063Z11/30 proportional directional valve. By increasing the flow resistance due to a flow rate increase, also the outside pressure difference has to be increased, in order to ensure the correct control function.

TV2-062/MC Meter-in compensator

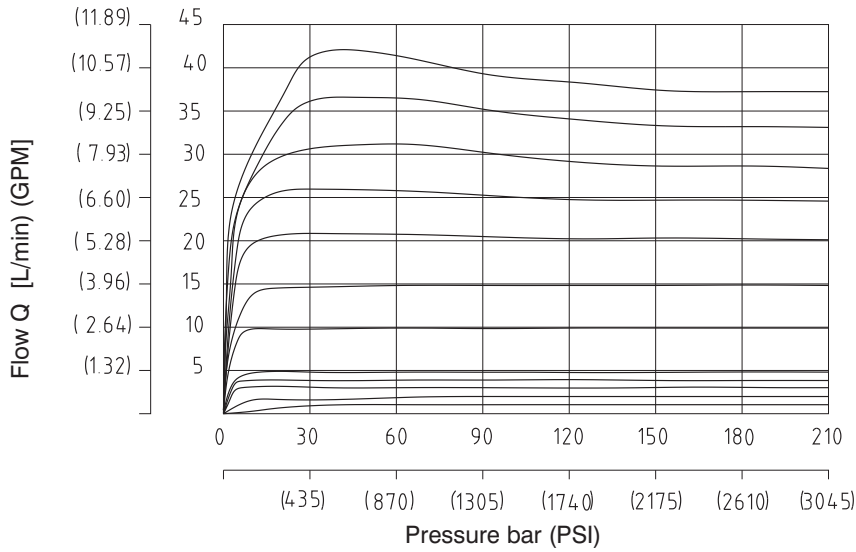

TV2-062/MD Meter-out compensator

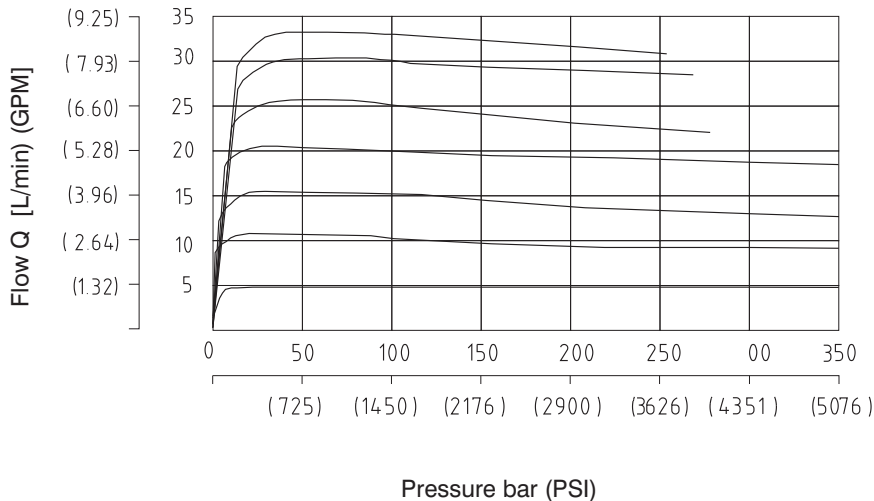

6

Valve Dimensions

Dimensions in millimeters (inches)

TV2-062/M Meter-in compensator

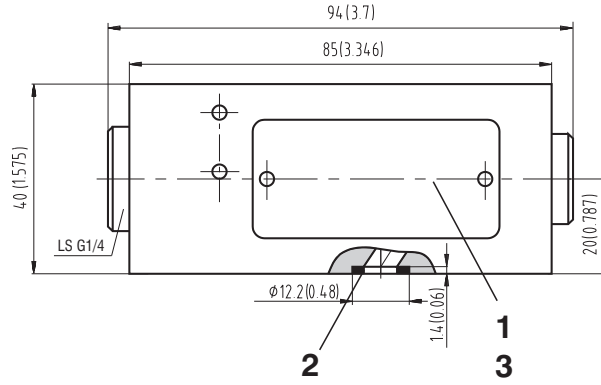
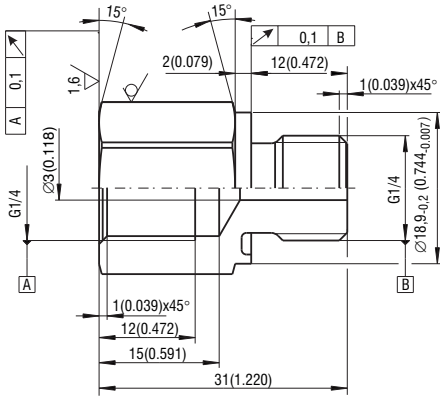

Adaptor G1/4/G1/4-ED

addition of equipment for LS connection
Ordering number: **28004900**

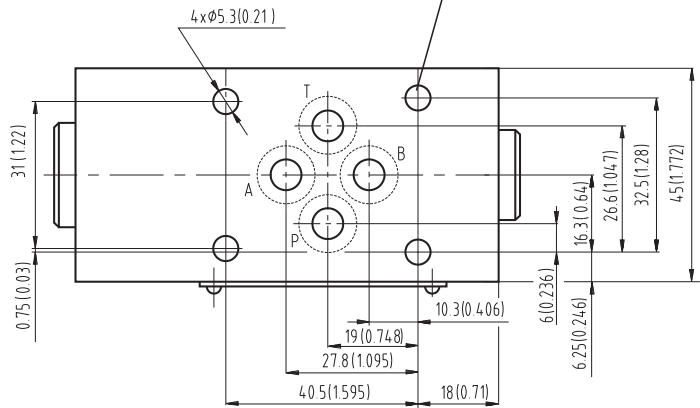

TV2-062/M Meter-out compensator

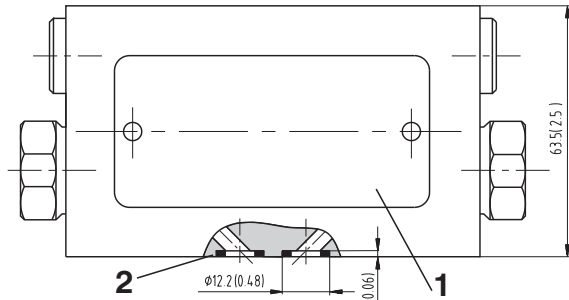

Dimensions in millimeters:

- 1 Name plate
- 2 Square ring 9.25 x 1.68 (4 pcs.)
- 3 4 mounting holes

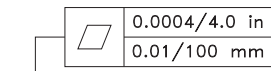

32 (Rmax. 4)
Required surface finish of interface

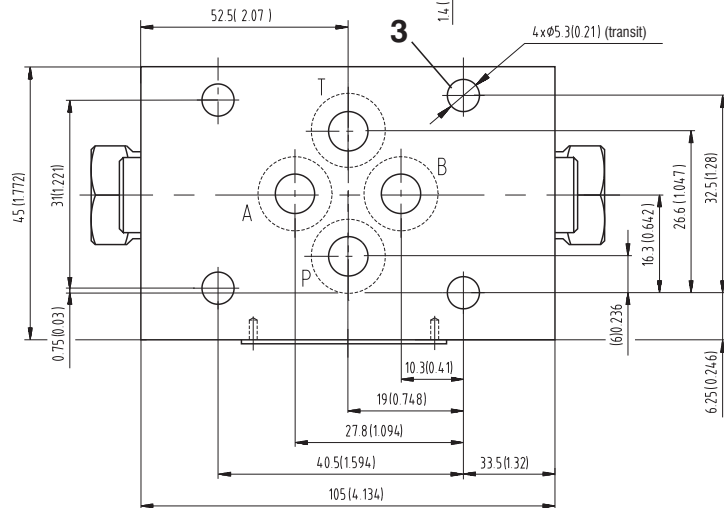

Caution!

- The packing foil is recyclable.
- The technical information regarding the product presented in this catalogue is for descriptive purposes only. It should not be construed in any case as a guaranteed representation of the product properties in the sense of the law.

ARGO-HYTOS s.r.o. CZ - 543 15 Vrchlaví
Tel.: +420-499-403 111
E-mail: info.cz@argo-hytos.com
www.argo-hytos.com

- Cartridge design
- Sandwich plate design for use in vertical stacking assemblies
- Build-in load sensing shuttle valve
- Installation dimensions to ISO 4401:1994 and DIN 24 340-A10
NFFA T3.5M R1 and ANSI B 93.7 D 05
- Possibility of LS-Signal through Adapter M10/G1/4-ED

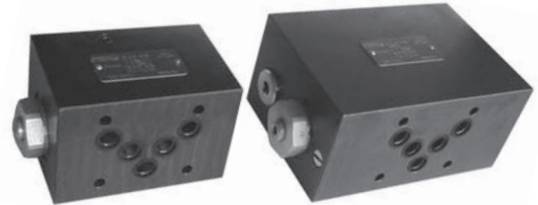
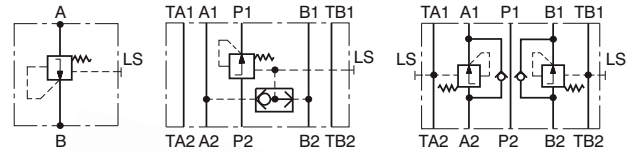

Functional Description

2 way pressure compensator for meter-in application

The 2 way pressure compensators in meter-in application will maintain a constant pressure difference across the metering edge of the proportional direction valve. In this case, the pressure variations due to load changes, as well as pump pressure changes are compensated so any increase in pump pressure does not affect the flow. The meter-in compensators may only be used with positive load direction.

Valves type TV2-102/MA,B,C are directly operated 2-way pressure compensators cartridge design in sandwich plate. They are designated for load compensation in channel P.

The main parts of these valves are the housing (1), control spool (2), spring (3) and shuttle valve (4). The spring (3) holds the spool in the open position from P2 to P1, provided that the pressure difference between P1 and A ($P1 - B$) is less than 10 bar. When the pressure difference exceeds the value of 10 bar, the spool shifts against the spring and throttled radial the housing openings until the desired pressure difference has been restored.

The pressure signal comes through passage (5) from channel A or B.

2 way pressure compensator for meter-out application

In systems with changing load directions, the use of meter-out pressure compensators is required. With

respect to the application a valve with pressure compensator installed in one, or in both actuator ports are available.

The pressure compensator is always mounted between the actuator and the proportional directional valve. The valve will maintain the pressure difference between A and T or B and T constant. The flow rate and the flow direction are adjusted by the proportional directional valve. To enable the reverse flow, two by-pass check valves are incorporated into the valve body.

The valve consists of the valve body (6), one or two control spools (7) and poppets of the by-pass check valves (8). If the pump, for example, is connected to port A, the fluid passes to the actuator through a check valve and returns from the actuator through channel B to the proportional directional valve. The pressure difference across the metering edge of the directional valve is maintained at a constant level. This ensures a constant flow rate independent to the load. The pressure difference is controlled by the metering edge (9), its value being determined by spring force (10). A similar valve function develops when the proportional valve ports P and B are connected.

Replacement of the steel end plug on the spring side by an adapter with outlet thread G1/4" allows measuring of "LS" signal.

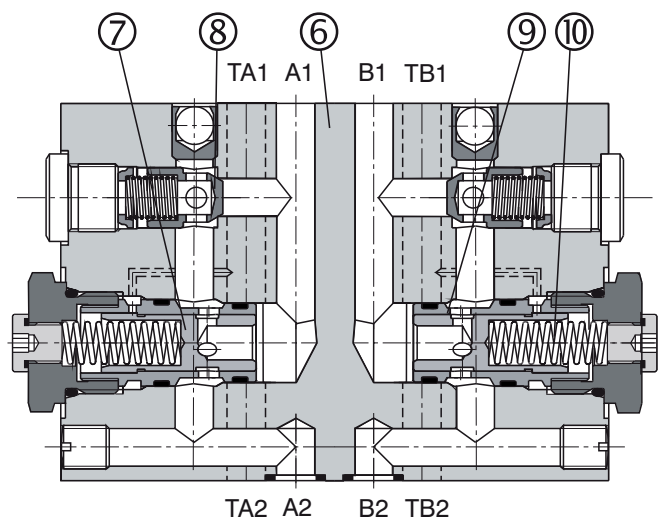
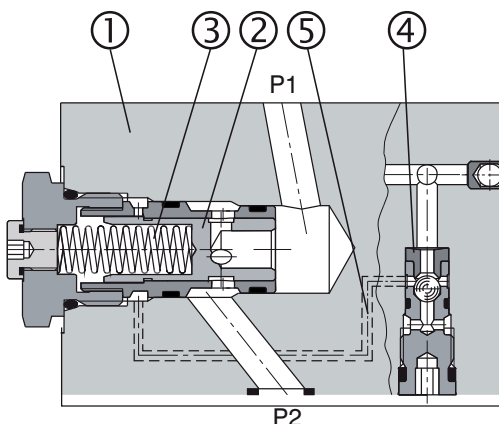

Ordering Code

TV2 - 102/

Pressure Compensator

Nominal size **10 (D 05)**

2 Way Pressure Compensator

Design

Cartridge
Sandwich plate

S
M

without designation
V

Seals
NBR
FPM (Viton)

Model

A Meter-in compensator - function in channel A
B Meter-in compensator - function in channel B
C Meter-in compensator - function in channels A and B
D Meter-out compensator - function in channels A and B
E Meter-out compensator - function in channel A
F Meter-out compensator - function in channel B

Technical Data

Nominal size (Valve size)	mm (US)	10 (D 05)
Maximum flow	L/min (GPM)	80 (21)
Max. operating pressure	bar (PSI)	350 (5076)
Pressure drop on valve Δp	bar (PSI)	10 (145)
Hydraulic fluid	Hydraulic oils of power classes (HL, HLP) to DIN 51524	
Maximum degree of fluid contamination	Class 21/18/15 to ISO 4406	
Weight TV2-102/S		0.15 (0.3)
TV2-102/MA (MB, MC)	kg (lbs)	3.70 (8.2)
TV2-102/MD (ME, MF)		6.65 (14.7)
Valve tightening torque for design S	Nm (lbf.ft)	70 (51.63)
Mounting position	unrestricted	

Functional Symbols

Model S

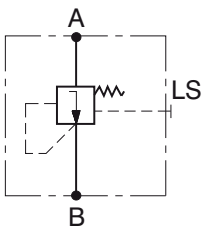

Model MA

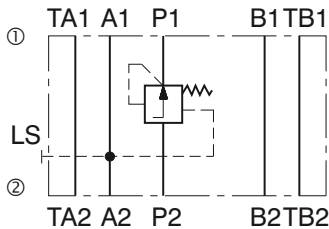

Model MB

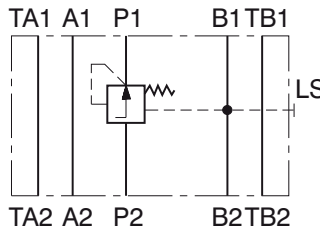

Model MC

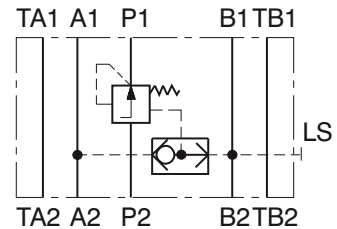

Model MD

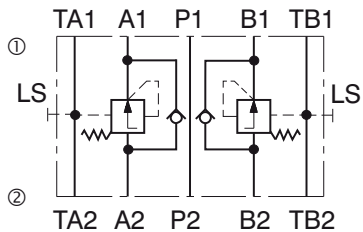

Model ME

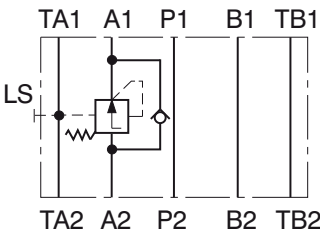

Model MF

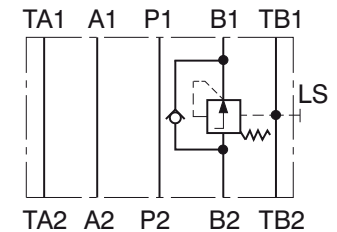

① valve side
② plate side

Typical Application

TV2-102/MC Meter-in compensator

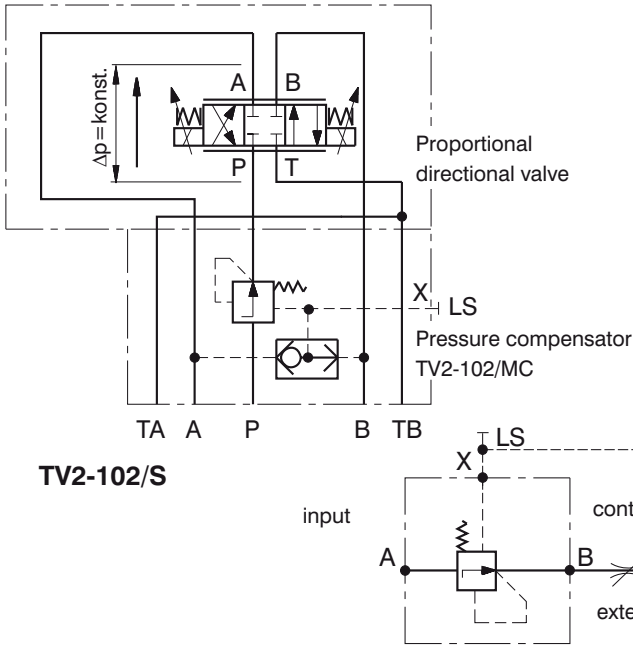

TV2-102/MD Meter-out compensator

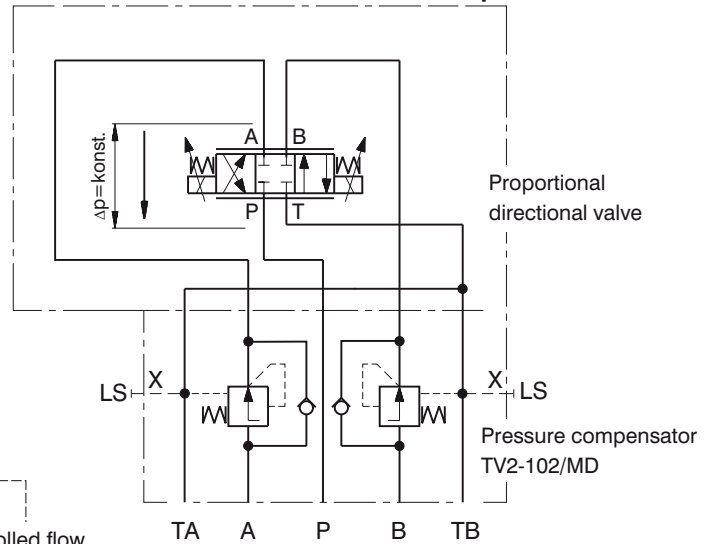

TV2-102/S

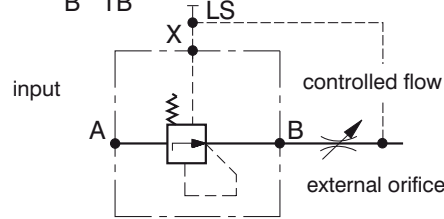

Characteristics

Measured at $v = 32 \text{ mm}^2/\text{s}$ (156,8 SUS)

The characteristic of the pressure compensator corresponds with the flow rate of a PRM2-103Z11/60 proportional directional valve.

TV2-102/MC Meter-in compensator

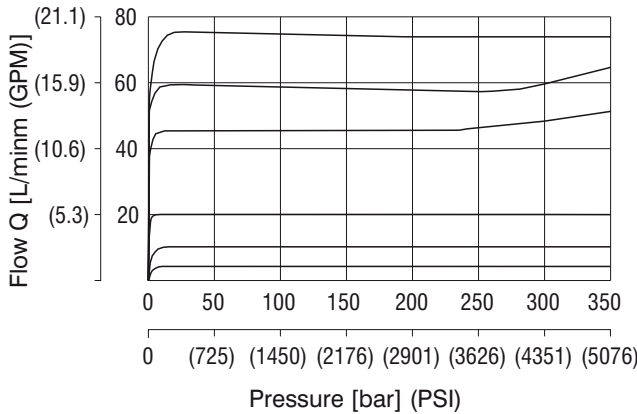

TV2-102/MD Meter-out compensator

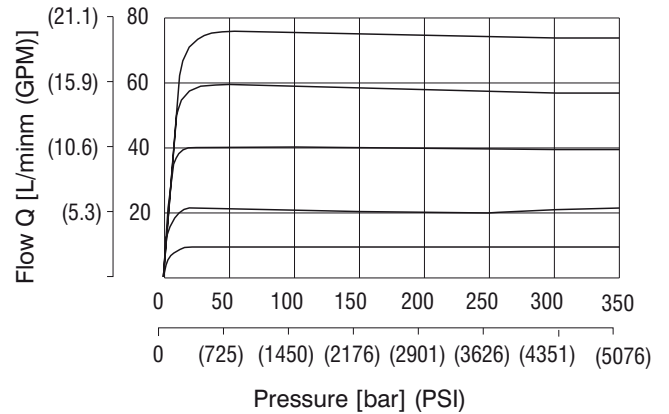

Valve Dimensions

Dimensions in millimeters (inches)

Adaptor M10/G1/4-ED
addition of equipment for LS connection
Ordering number: **19860700**

TV2-102/S

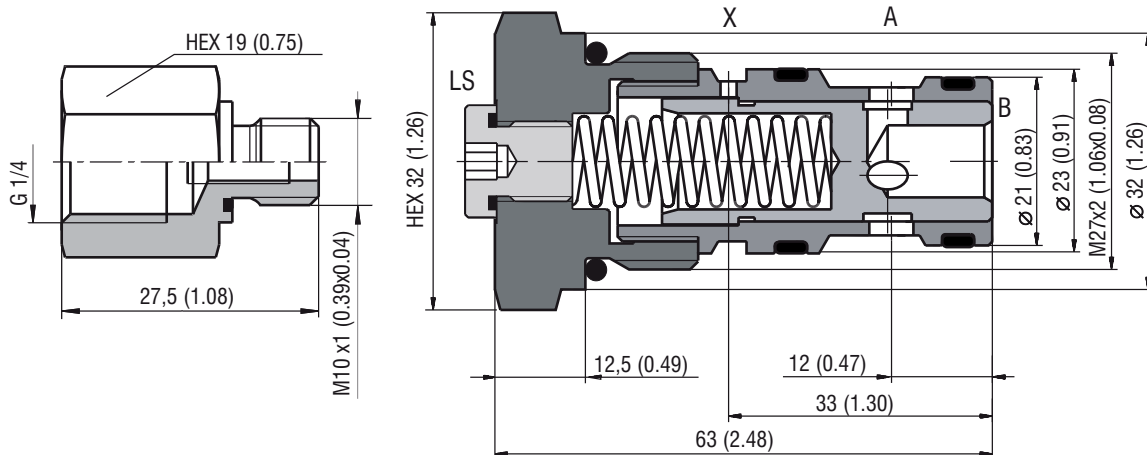

Installation cavity TV2-102

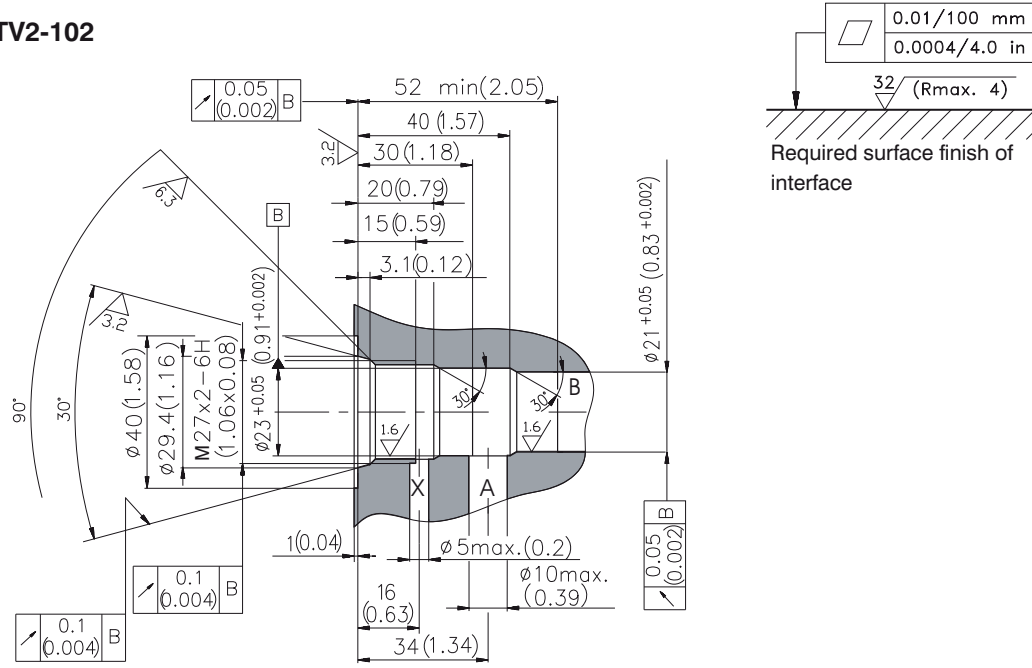

TV2-102/M Meter-in compensator

TV2-102/M Meter-out compensator

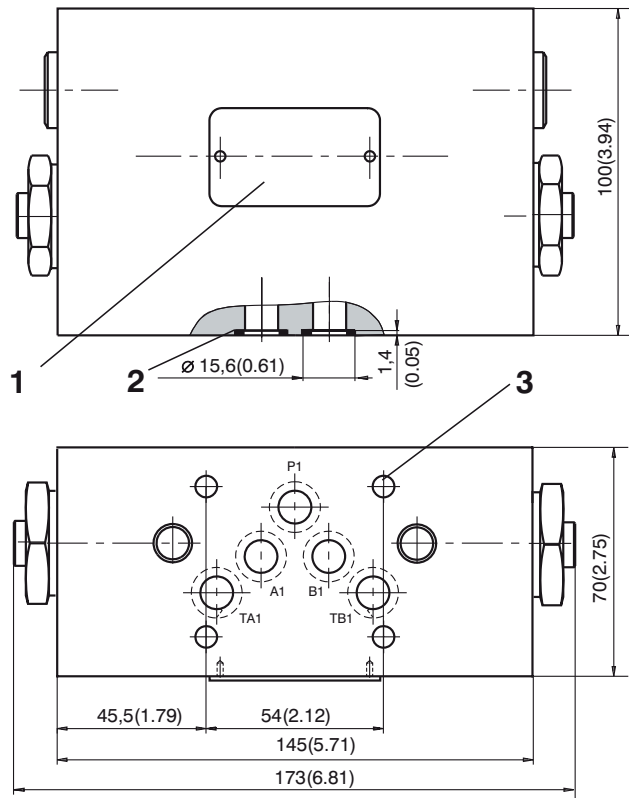
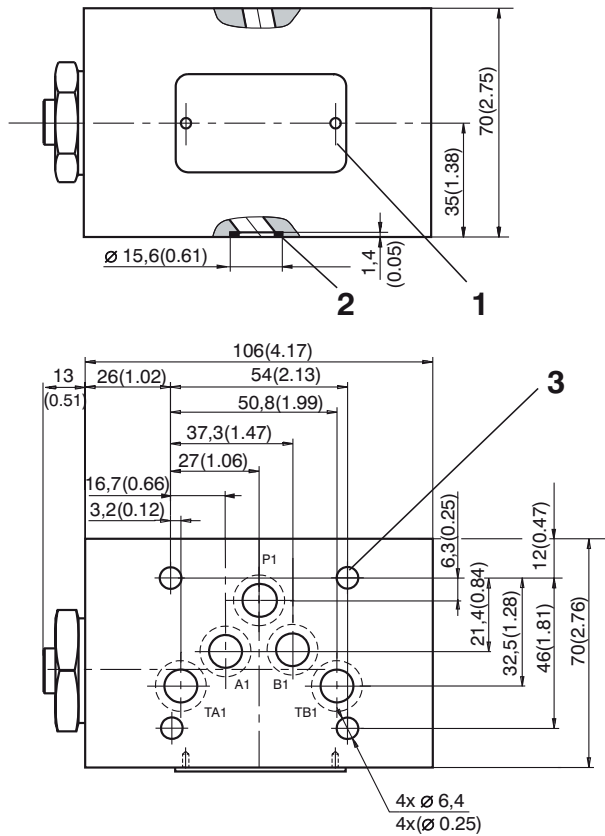

- 1 Name plate
- 2 Square Ring 014S - 12.42 x 1.68 (5 pcs.)
(supplied with valve)
- 3 4 mounting holes

Caution!

- The packing foil is recyclable. The protective plate can be returned to manufacturer.
- The technical information regarding the product presented in this catalogue is for descriptive purposes only. It should not be construed in any case as a guaranteed representation of the product properties in the sense of the law.

ARGO-HYTOS s.r.o. CZ - 543 15 Vrchlaví
 Tel.: +420-499-403 111
 E-mail: info.cz@argo-hytos.com
 www.argo-hytos.com

- Sandwich plate design for use in vertical stacking assemblies
- With integrated logic valve
- Pressure difference adjustable from 5 - 40 bar
- Installation dimensions to ISO 4401 CETOP-RP 121H, ISO 4401:1994 and DIN 24 340-A6

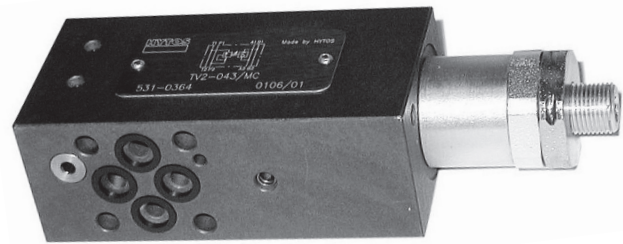
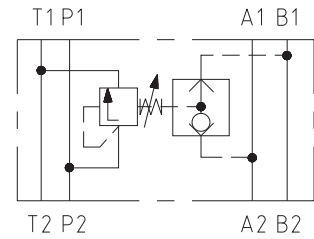

Functional Description

The valves TV2-043/M and TV2-063/M are designed as a sandwich plate of size 04 and 06. They consist of a body, a logic valve and a pressure compensator with control spool.

The ports A and B are always connected through the logic valve seat with the spring side of spool. The higher pressure pushes the ball onto the seat that is affected by lower pressure. This always causes the channel with the higher pressure to be connected with the control spool spring room.

The required pressure difference between port P and the spring room is adjusted. When the pressure difference

between P and the spring room exceeds the value set, the control spool shifts, causing the part of pressure fluid to pass from P to T until the desired pressure difference has been restored.

Usually, this pressure compensator is used in connection with a proportional directional valve. In this case, each value of the control signal a particular constant flow rate can be assigned, this being independent of load.

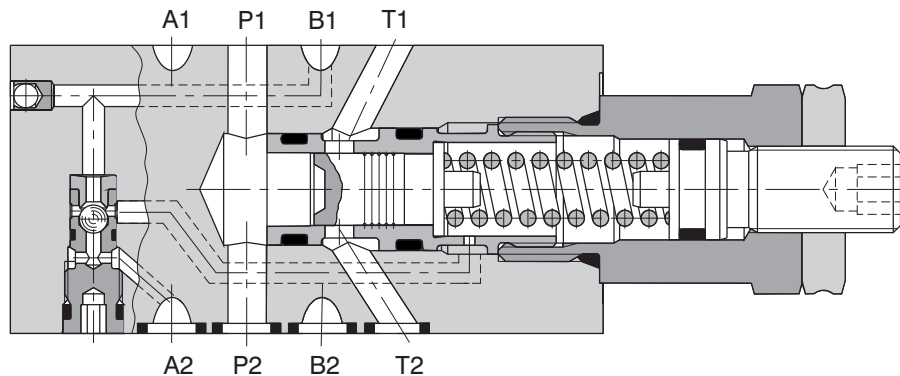

Ordering Code

TV2 - **3/M**

Pressure Compensator

without designation

Seals
NBR
FPM (Viton)

Nominal size

size 04
size 06

04
06

A
B
C

Model
in channel A
in channel B
in channels A and B

3 way Pressure Compensator

Sandwich plate design

Technical Data

Nominal size	mm	04	06
Maximum flow	L/min	20	40
Max. operating pressure	bar	350	
Pressure drop on valve Δp	bar	5 - 40	
Hydraulic fluid	Hydraulic oils of power classes (HL, HLP) to DIN 51524		
Maximum degree of fluid contamination	Class 21/18/15 to ISO 4406		
Weight (Model A,B,C)	kg	0.6	1.00
Mounting position	unrestricted		

Functional Symbols

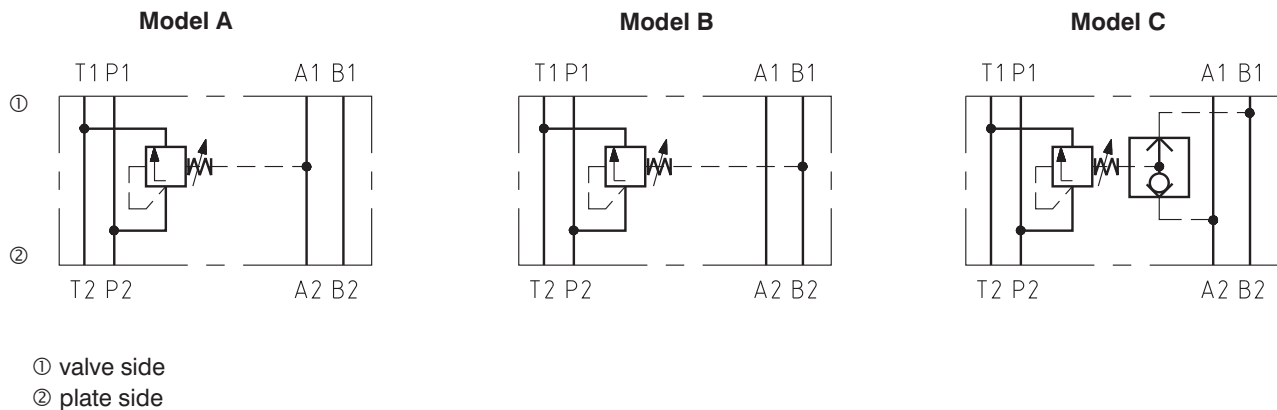

Typical Applications

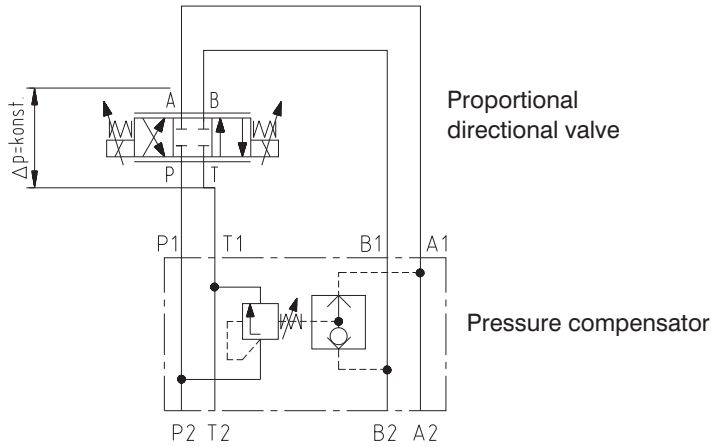

Characteristics

Measured at $v = 32\text{mm}^2/\text{s}$

The characteristic of the pressure compensator corresponds with the flow rate of a PRM2-043Z11/12 and PRM2-063Z11/30 proportional directional valve. By increasing the flow resistance due to a flow rate increase, also the outside pressure difference has to be increased, in order to ensure the correct control function.

Tv2-043/M

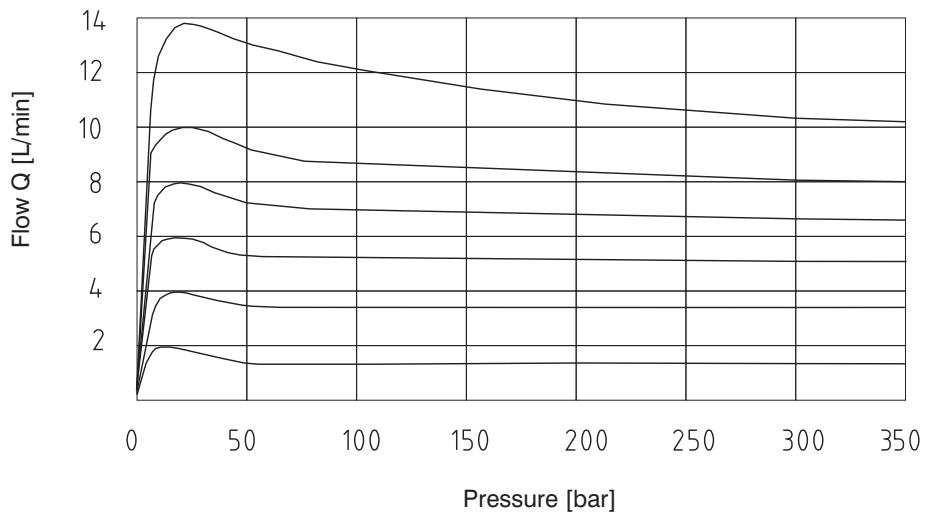

TV2-063/M

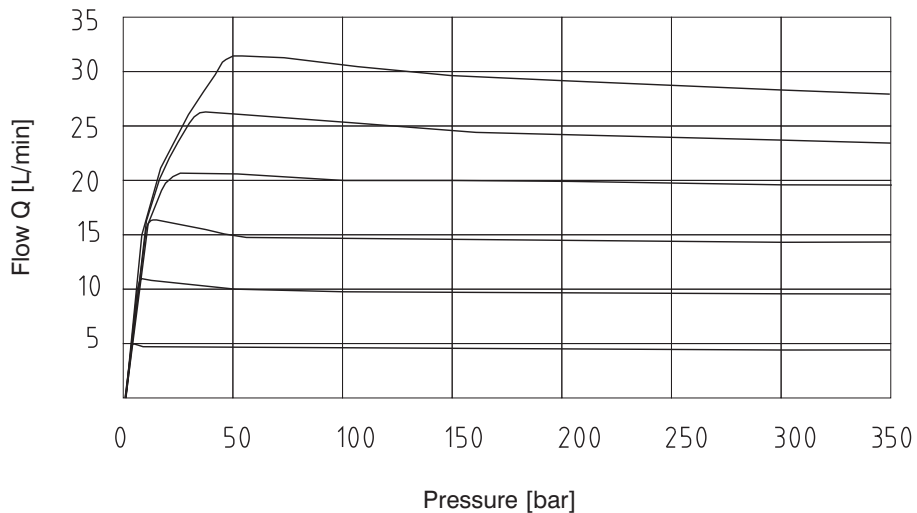

6

Valve Dimensions

Dimensions in millimetres

TV2-043/M

- 1 Name plate
- 2 Square ring 7.65 x 1.68 (4 pcs.)
- 3 4 mounting holes

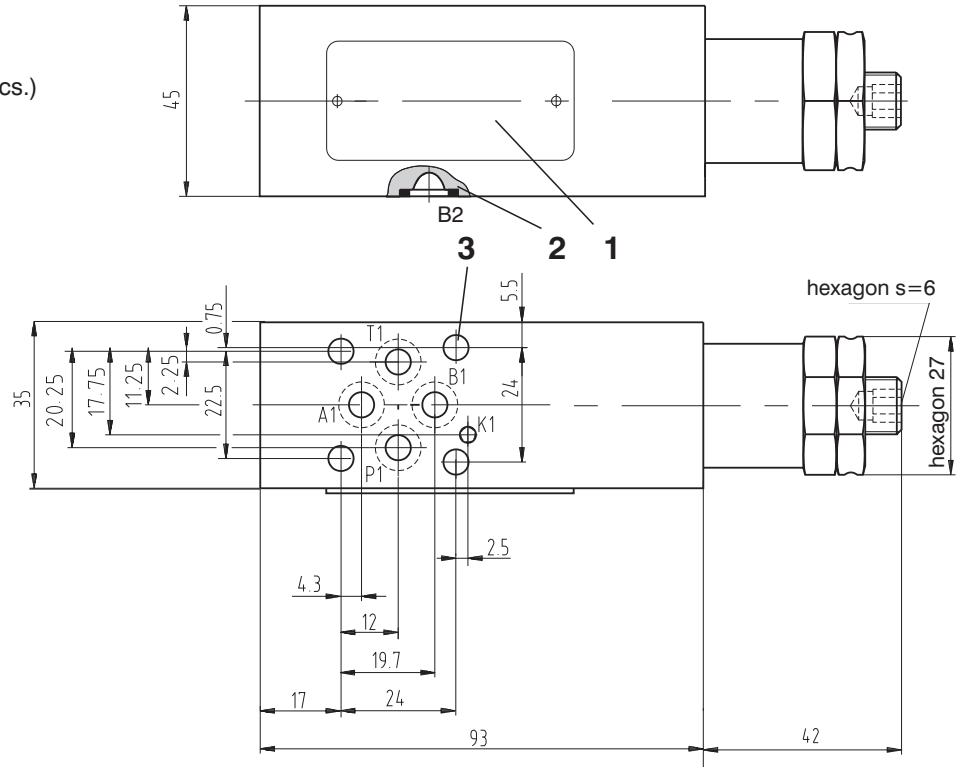

TV2-063/M

- 1 Name plate
- 2 Square ring 9.25 x 1.68 (4 pcs.)
- 3 4 mounting holes

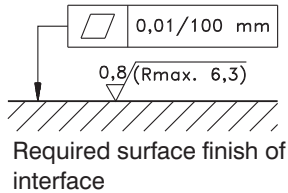
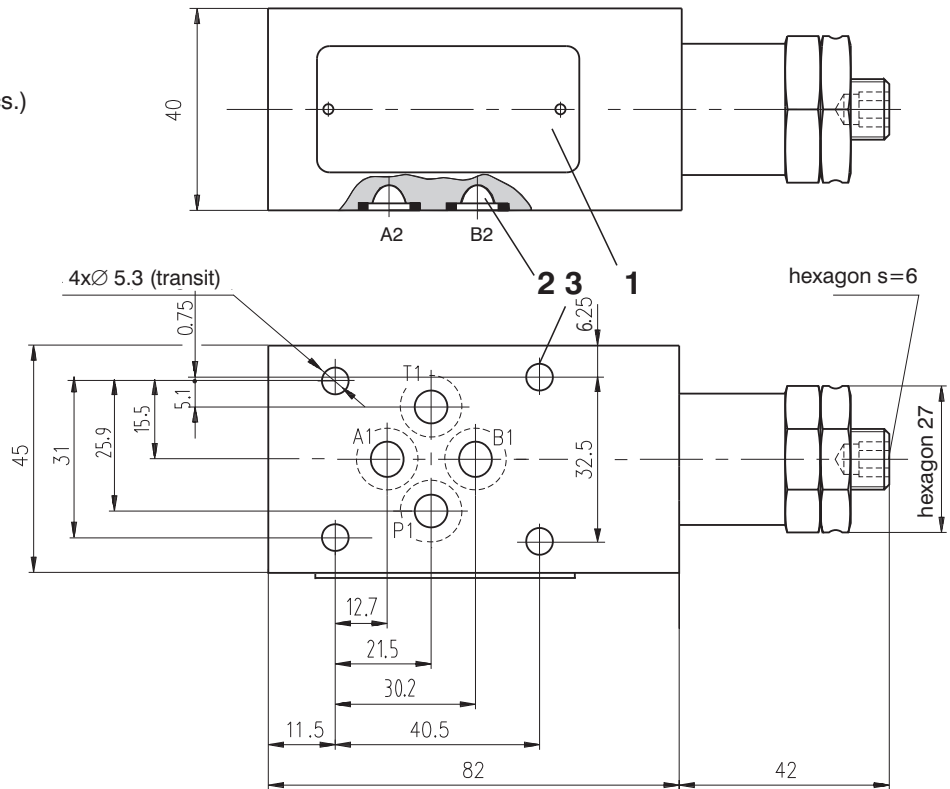

Caution!

- The packing foil is recyclable. The protective plate can be returned to manufacturer.
- The technical information regarding the product presented in this catalogue is for descriptive purposes only. It should not be construed in any case as a guaranteed representation of the product properties in the sense of the law.

ARGO-HYTOS s.r.o. CZ - 543 15 Vrchlaví
 Tel.: +420-499-403 111
 E-mail: info.cz@argo-hytos.com
 www.argo-hytos.com

- Cartridge design
- Sandwich plate design for use in vertical stacking assemblies
- With integrated logic valve
- Installation dimensions to ISO 4401 and DIN 24 340-A10; NFPA T3.5.1M R1 and ANSI B 93.7 D 05
- Possibility of LS-Signal through Adapter M10/G1/4-ED

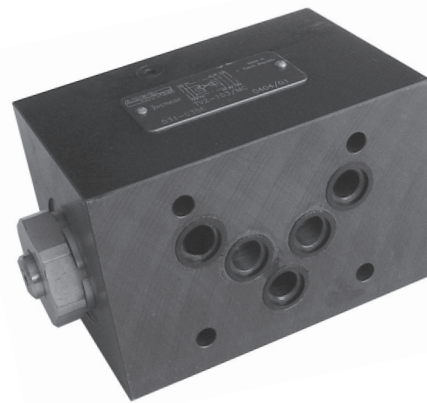
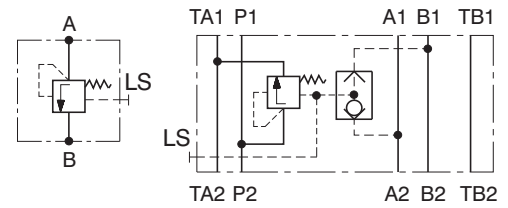

Functional Description

The valve TV2-103 is designed as a sandwich and cartridge plate. Sandwich design consist of a body (1), cartridge pressure compensator (2) with control spool (3) and logic valve in model "C" - where the ports A and B are always connected through the logic valve seat with the spring side of spool. The higher pressure pushes the ball onto the seat that is affected by lower pressure. This always causes the channel with the higher pressure to be connected with the control spool spring room (4). The required pressure difference between port P and the spring room is adjusted. When the pressure difference

between P and the spring room exceeds the value set, the control spool shifts, causing the part of pressure fluid to pass from P to T until the desired pressure difference has been restored.

Usually, this pressure compensator is used in connection with a proportional directional valve. In this case, each value of the control signal a particular constant flow rate can be assigned, this being independent of load. The valve body is phosphated, all other parts are zinc coated.

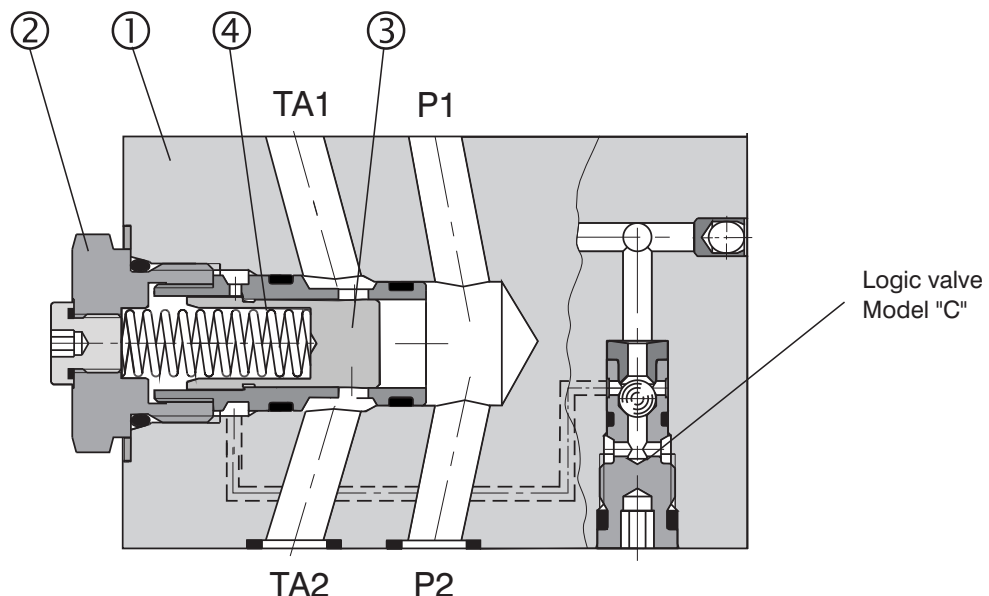

Ordering Code

TV2 - 10 3/

Pressure Compensator

Nominal size

10 (D05)

3 Way Pressure Compensator

Design

Cartridge
Sandwich plate

S
M

without designation
V

Seals

NBR
FPM (Viton)

Model

function in channel A
function in channel B
function in channels A and B

Technical Data

Nominal size	mm (US)	10 (D 05)
Maximum flow	L/min (GPM)	80 (21)
Max. operating pressure	bar (PSI)	350 (5076)
Pressure drop on valve Δp	bar (PSI)	10 (145)
Hydraulic fluid	Hydraulic oils of power classes (HL, HLP) to DIN 51524	
Maximum degree of fluid contamination	Class 21/18/15 to ISO 4406	
Weight TV2-103/MA (MB, MC) TV2-103/S	kg (lbs)	3.70 (8.2) 0.15 (0.3)
Valve tightening torque for design S	Nm (lbf.ft)	70 (51.63)
Mounting position	unrestricted	

Functional Symbols

Model S

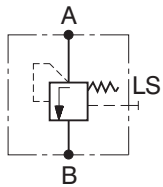

① valve side
② plate side

Model MA

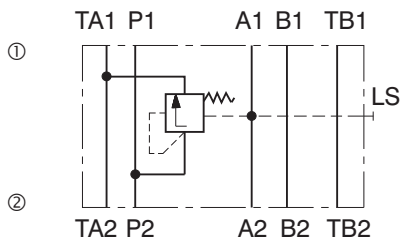

Model MB

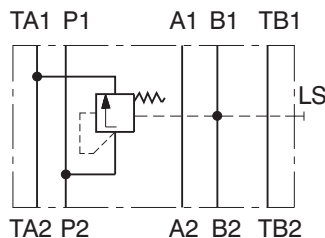

Model MC

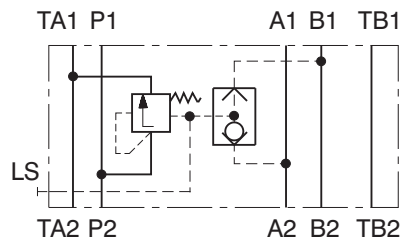

Typical Applications

TV2-103/MC

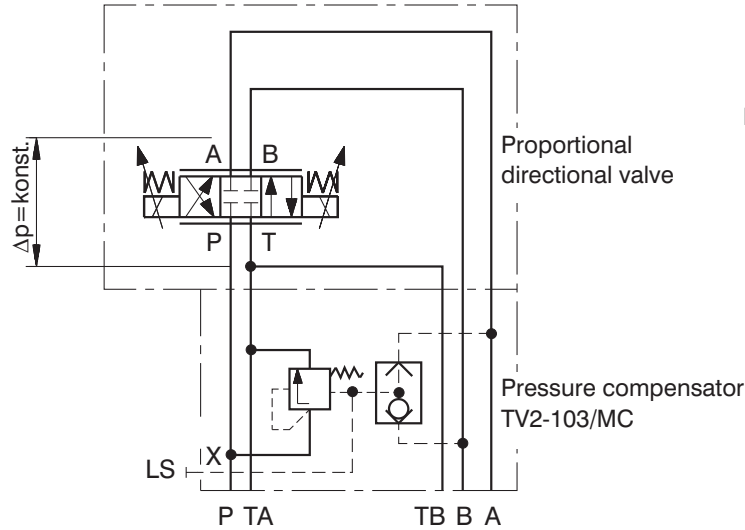

TV2-103/S

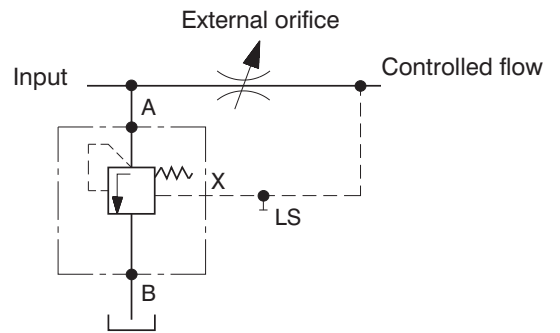

Characteristics

Measured at $v = 32 \text{ mm}^2/\text{s}$ (156 SUS)

The characteristic of the pressure compensator corresponds with the flow rate of a PRM2-103Z11/60 proportional directional valve.

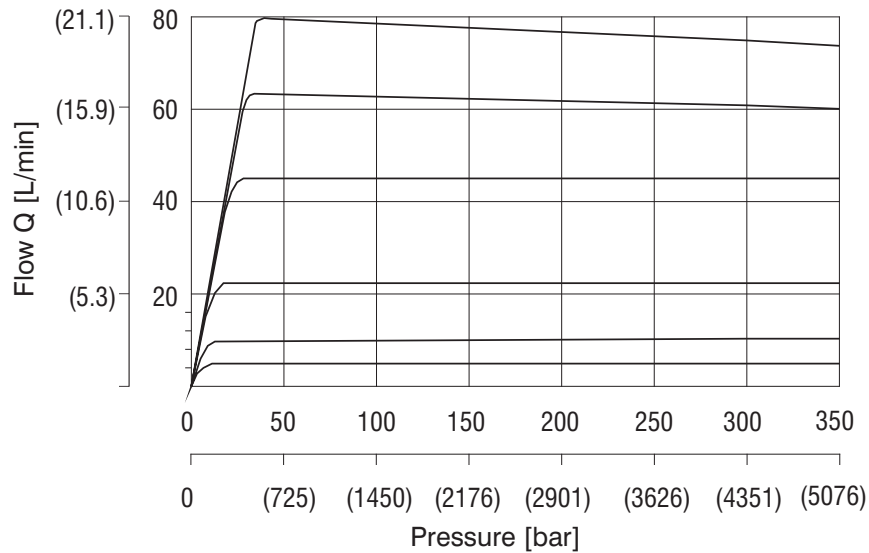

Valve Dimensions

Dimensions in millimeters (inches)

Adaptor M10/G1/4-ED

addition of equipment for LS connection
Ordering number: **19860700**

TV2-103/S

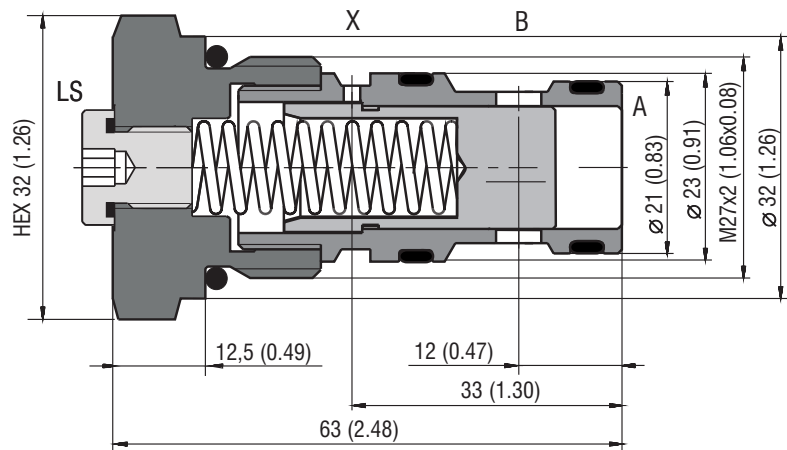
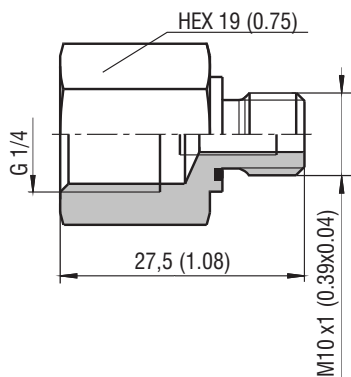

Installation cavity TV2-103

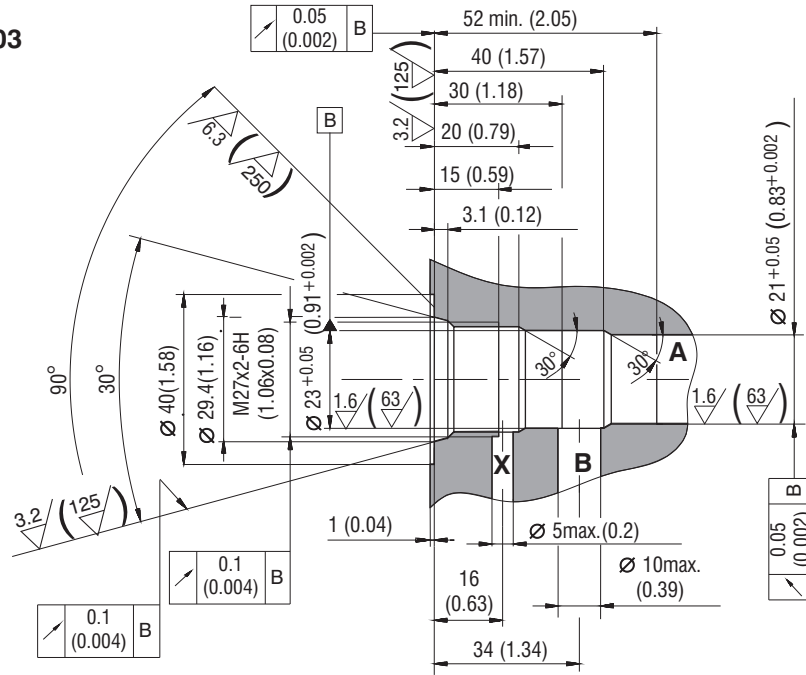

TV2-103/M

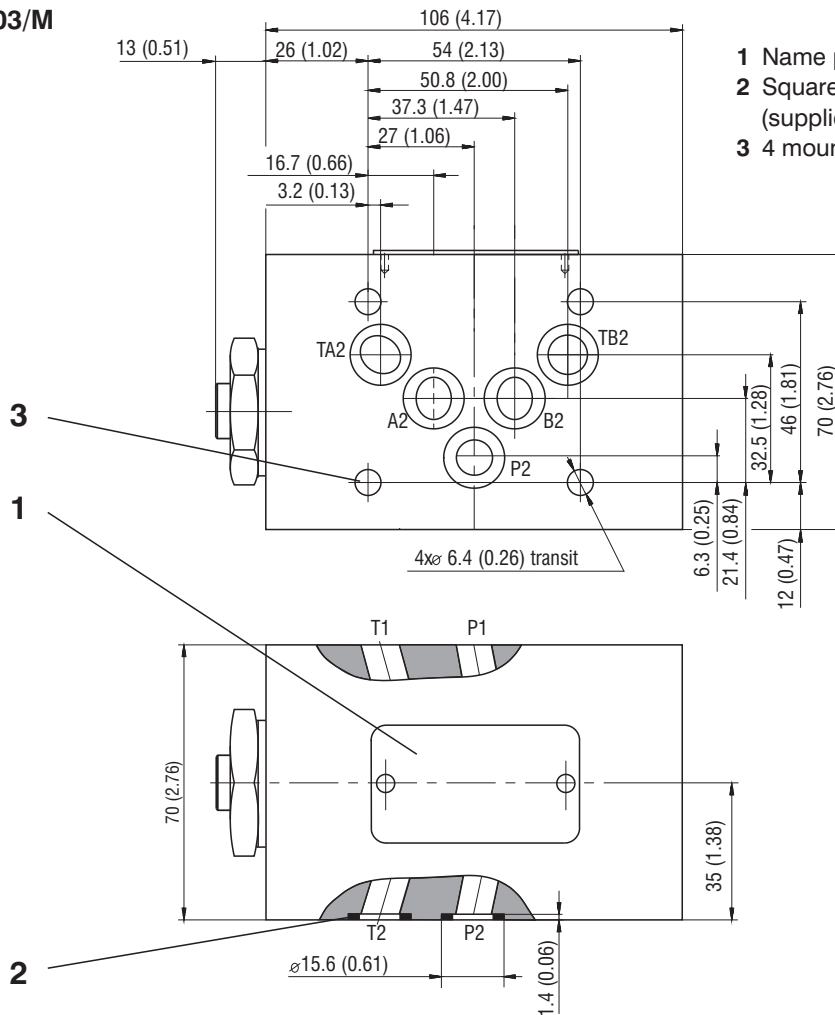

- 1 Name plate
- 2 Square ring 014S - 12,42 x 1,68 (5 pcs.) (supplied with valve)
- 3 4 mounting holes

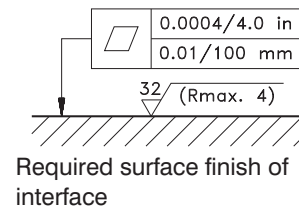

Caution!

- The packing foil is recyclable. The protective plate can be returned to manufacturer.
- The technical information regarding the product presented in this catalogue is for descriptive purposes only. It should not be construed in any case as a guaranteed representation of the product properties in the sense of the law.

ARGO-HYTOS s.r.o. CZ - 543 15 Vrchlaby
 Tel.: +420-499-403 111
 E-mail: info.cz@argo-hytos.com
 www.argo-hytos.com

- High parameters of controlled flow rates
- Continuous control of both flow rate directions
- High reliability
- Indirect control concept with a floating spool
- Installation dimensions to DIN 24 340 / ISO 4401 / CETOP RP121-H

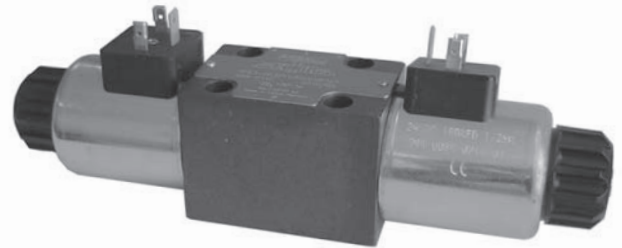
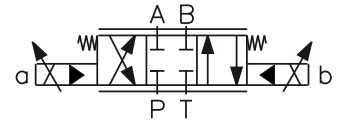

Functional Description

The proportional directional control valve consists of a cast-iron body (1), main spool (2), control spool (3), two auxiliary centring springs (4), two main return springs (5) and two proportional solenoids (6).

The pilot controlled main spool valve copies the control spool position, which is given the control current of the solenoid.

The central position of the main spool is defined by the auxiliary centring springs.

The solenoids are supplied from an external source, which should be provided with a current feedback.

In order to achieve optimum operating parameters the external electronics should be able to generate an additional dither - signal. The proportional valve can be used within the whole range of input pressure, where

within the required continuity of the flow-rate characteristics and minimum hysteresis is achieved.

The selected concept increases the achieved output parameters of the proportional valve in comparison to direct controlled proportional valve. Further on the valve shows a monotone increasing relation between pressure gradient and flow rate by constant control current.

Proper functions of the valve are guaranteed only, if the supply pressure in the "P" channel is present; this pressure must be always higher than the pressure in the "T" channel.

The basic surface treatment of the valve housing is phosphate coated and the operating solenoids are zinc coated.

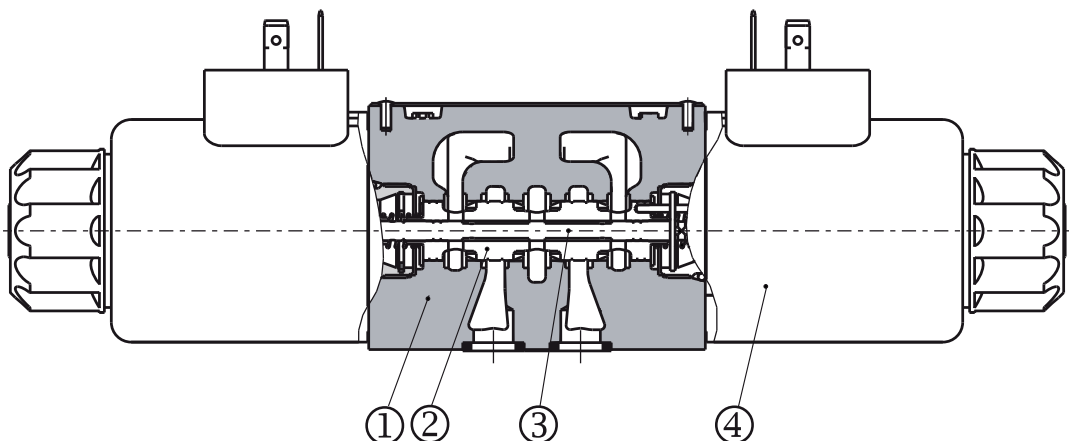

Ordering Code

PRM8-06 -

Proportional Directional Control Valve

Nominal size

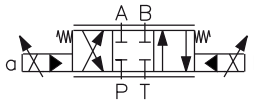

3Z11

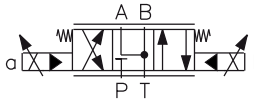

3Y11

Nominal supply voltage

12 V DC	12
24 V DC	24

no designation
V

Seals
NBR
FPM (Viton)

Type of solenoid coil and Electronics

- Type of solenoid coil

E1 Connector EN 175301-803-A
E2 Connector EN 175301-803-A with quenching diode
E3A Axial connector AMP Junior Timer (2 pins; male)
E4A Axial connector AMP Junior Timer with quenching diode
E12 Connector Deutsch DT04-2P (2 pins; male)
E13 Connector Deutsch DT04-2P with quenching diode

Other coils on demand see catalog HA 8007.

Electronics for controlling proportional valves is possible to order separately, see catalog HA 9150.

6

Technical Data

Nominal size	mm (US)	06
Maximum operating pressure at ports P, A, B	bar (PSI)	350 (5076)
Maximum flow at pressure 320 bar (4641PSI)	l/min (GPM)	140 (37)
Maximum operating pressure at port T	bar (PSI)	210 (3046)
Hydraulic fluid		Hydraulic oils of power classes (HL, HLP) to DIN 51524
Fluid temperature range (NBR / Viton)	°C (°F)	-30 ... +80 (-22 ... +176) / -20 ... +80 (-4 ... +176)
Ambient temperature, max.	°C (°F)	+50 (+122)
Viscosity range	mm ² /s (SUS)	20 ... 400 (98 ... 1840)
Maximum degree of fluid contamination		Class 21/18/15 according to ISO 4406
Nominal flow rate Q _n at Δp = 10 bar (145PSI) (v = 32 m ² m.s ⁻¹ (156 SUS))	l/min (GPM)	25 (6.60)
Hysteresis	%	≤ 6
Weight PRM8-063	kg (lbs)	2,4 (5.29)
Mounting position		unrestricted, preferably horizontal
Enclosure type EN 60 529		IP 65

Technical Data of the Proportional Solenoid

Type of coil	V	12 DC	24 DC
Limit current	A	2,5	1,6 (12 V electronic) 1,0
Resistance at 20 °C (68 °F)	Ω	2,3	5.2 (12 V electronic) 13,4

Technical Data of the Electronics

Nominal supply voltage U _{cc}	V	12 DC	24 DC
Supply voltage range	V	11,2 ... 14,7	20 ... 30 DC
Stabilized voltage for control	V	5 DC (R > 1 kΩ)	10 DC (R ≥ 1 kΩ)
Maximum output current	A	2.4 for R < 4 Ω	1,5 for R < 10 Ω
Ramp adjustment range	s	0,05...3	
Dither frequency	Hz	90 / 60	
Dither amplitude	%	0...30	

Valve Dimensions

Dimensions in millimeters (inches)

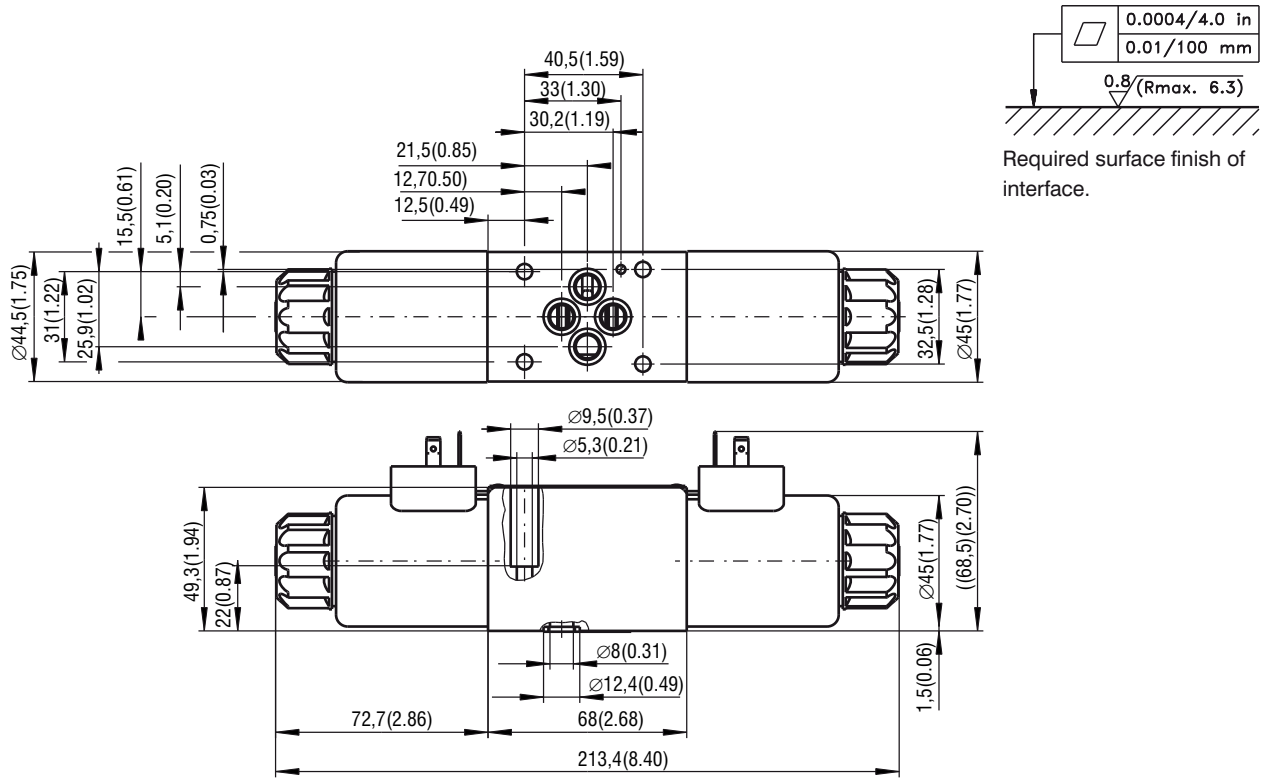

Limit power

Measured at $v = 32 \text{ mm}^2/\text{s}$ (156 SUS)

$P \rightarrow A / B \rightarrow T$ or $P \rightarrow B / A \rightarrow T$

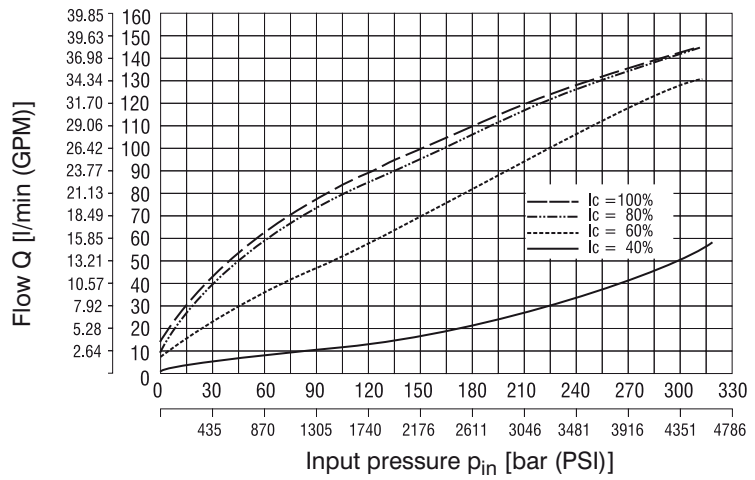

Flow Characteristic

Measured at $v = 32 \text{ mm}^2/\text{s}$ (156 SUS)

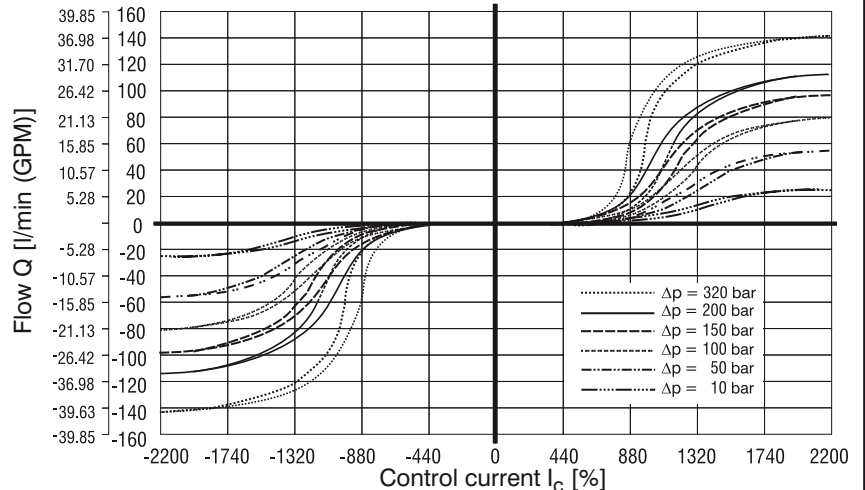

The coil current which initializes the flow through the proportional directional valve can differ due to the production tolerances in a range of $\pm 6\%$ of the limit current.

6

Spare Parts

- 1 Solenoid coil
- 2 Seal kit
- 3 Connector plug EN 175301-803-A
- 4 Bolt kit
- 5 Nut + seal ring

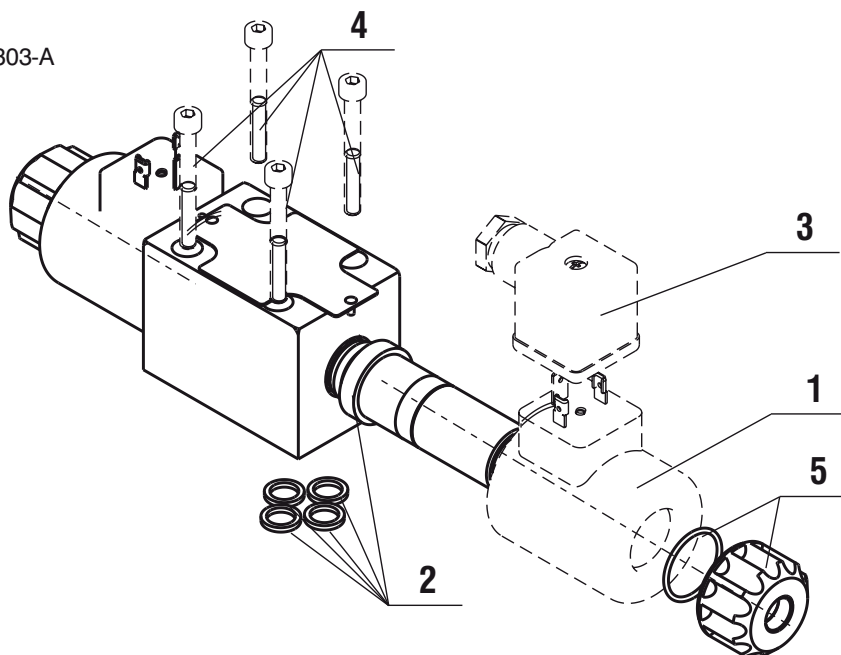

1. Solenoid coil		Ordering number			
		E1	E3A	E12	E13
Nominal supply voltage [V]		Ordering number			
12		18838500	19744700	19696100	19909300
24		18838300	19744300	19696200	28811200
2. Seal kit					
Type		Dimensions, number		Ordering number	
Viton		9,25 x 1,78 (4 pcs)	17,17 x 1,78 (2pcs)	15845400	
3. Connector plug EN 175301-803-A					
Type designation	Type	Model	Max. input voltage	Ordering number	
K1	Connector B (černá)	bez usměřovače - M16x1,5 (otvor průchodky Ø 6-8 mm)	230 V AC/DC	16202100	
	Connector A (šedá)			16202200	
4. Bolt kit					
Dimensions, number		Tightening torque		Ordering number	
M5 x 45 DIN 912-10.9 (4 pcs)		8,9 Nm (6.56 lbf.ft)		15845100	
5. Nut + seal ring					
Type of the nut		Seal ring		Ordering number	
Standard nut		22 x 2		15844600	

Caution !

- The packing foil is recyclable.
- The protective plate can be returned to manufacturer.
- Mounting bolts M5 x 45 DIN 912-10.9 or studs must be ordered separately.
Tightening torque of the bolts is 8,9 Nm (6.6 ft-lbs).
- The technical information regarding the product presented in this catalogue is for descriptive purposes only. It should not be construed in any case as a guaranteed representation of the product properties in the sense of law.

ARGO-HYTOS s.r.o. CZ - 543 15 Vrchlabí
tel.: +420-499-403111, fax: +420-499-403421
e-mail: sales.cz@argo-hytos.com
www.argo-hytos.com

Hydraulic Power Packs

7

Hydraulic Power Packs

Type Code	Motor output (kW)	Flow l/min (GPM)	Pressure bar (PSI)	Page	Data Sheet
SPA 01	3,0	17 (5)	250 (3600)	7.01	HA 7111
SMA05	3,0	17 (5)	250 (3600)	7.03	HA 7212
SA4	7,5	50 (13)	250 (3600)	7.02	HA 7100

- Small compact power packs used in lifting platforms, ramps and other applications
- 3 basic hydraulic circuits
- Low noise level
- High power ratio in relation to envelope dimensions
- Tank capacities from 7 to 30 L
- Possibility of building up an addition circuit in the form of horizontal stacking assembly of the size 04 or 06

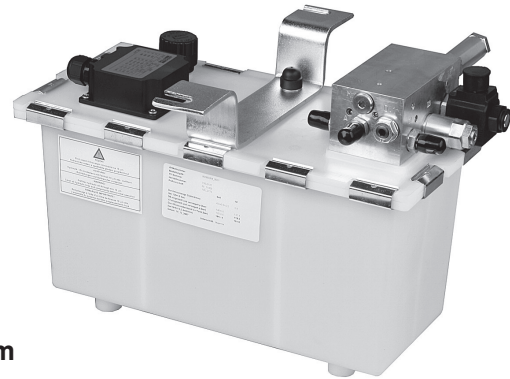

Functional Description

The under oil power packs are designed for applications which require low noise level as well as small envelope dimensions. They are supposed to work only occasionally, thus being suitable mainly for the use in lifting platforms, elevating tables and handling devices. The electric motor (1) and the pump (2) are connected through a cross coupling. The electric connection of the electric motor with the power pack terminal board is realized through a tight bushing (4) which is fixed to the tank cover. The whole drive (electric motor + pump) is flexibly suspended by means of holder on the lower side of the tank cover.

Mounted on a lug, which is situated on the upper side of the tank cover, is block (5). The fluid under pressure delivered by the pump is led to this block by hose (6). The filtration of the fluid is provided by suction filter (7). The air is filtered by an air filter which is integrated into the filling plug (10). The filling plug serves also as the scale for measuring the oil level. The block according to the hydraulic circuit S11 forms the base, on which the connecting plates of the horizontal stacking assembly (size 04 or 06) can be mounted.

PHASE - CONNECTIONS FOR CORRECT DIRECTION OF MOTOR ROTATION

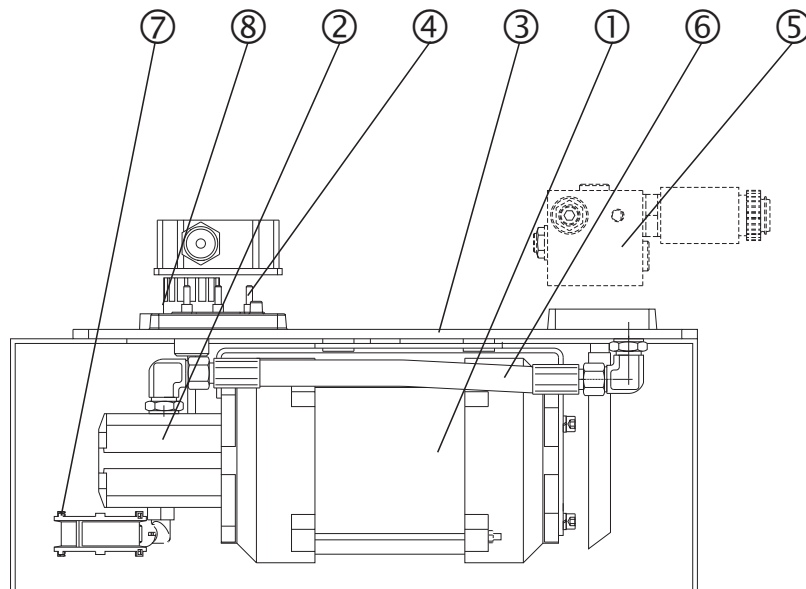
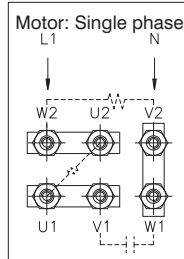
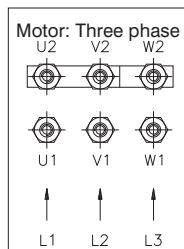

Ordering Code

SPA 01 - / . - - - /

Under Oil Power Pack

Displacement of the pump

0,8 cm ³ /Um.	08
1,2 cm ³ /Um.	02
1,6 cm ³ /Um.	16
2,1 cm ³ /Um.	21
2,5 cm ³ /Um.	25
3,3 cm ³ /Um.	33
3,6 cm ³ /Um.	36
4,4 cm ³ /Um.	44
4,8 cm ³ /Um.	48
5,8 cm ³ /Um.	58
6,2 cm ³ /Um.	62
7,9 cm ³ /Um.	79

Code of the electric motor - see Tab. 1

Start-up module

- without start-up module
- with start-up module

0
M

Type of the block - see page 3

Code of the tank

7	7 L
10	10 L
20	20 L
30	30 L

Solenoid voltage

01200	12V DC
01400	14V DC
02100	21V DC
02400	24V DC
04200	42V DC
04800	48V DC
06000	60V DC
10200	102V DC
20500	205V DC
02450	24V / 50 (60)Hz
11550	115V / 50 (60)Hz
23050	230V / 50 (60)Hz

Nominal size of stacking assembly elements

0	Without stacking assembly
3	Size 03
4	Size 04
6	Size 06

Number of add-on units

0	Without stacking assembly
1	1 Section
2	2 Sections
3	3 Sections
4	4 Sections
5	5 Sections

Technical Data

Flow rate	L/min	Tab. 1	
Working pressure	bar	Tab. 1	
Max. working/peak pressure	bar	Tab. 1	
Tank capacity	L	7, 10, 20, 30	
Type of the pump		external gear pump	
Power of the electric motor	kW	0,55 to 3	
Load factor of the electric motor	%	20	
Type of the electric motor		single phase	three phase
Voltage of the electric motor	V	230	400
Frequency	Hz	50	50
Enclosure type of the electric motor		IP 54	
Hydraulic fluid		Hydraulic oils of power classes (HL, HLP) to DIN 51524	
Viscosity range	mm ² /s	20 ... 100	
Maximum degree of fluid contamination		Class 21/18/15 to ISO 4406	
Fluid temperature range	°C	-30 ... +80	
Ambient temperature max.	°C	+50	
Thread of the connecting ports P, T, M, (A, B)		G 1/4	
Working position		horizontal	

7

Tab. 1

Code of the electric motor			Code of the pump					
			08 P2..	12 P2..	16 P2..	21 P2..	25 P2..	33 P2..
	$p_{max.}^{**}$ [bar]		250					
R.P.M.	400 V	kW	$Q / p_n * [L/min] / [bar]$					
1500	13	0.55		1.5/175	2.0/130	2.6/100	3.1/85	4.2/65
	14	0.75			1.9/190	2.5/145	3.0/120	3.9/90
	15	1.1			2.1/200	2.8/190	3.3/160	4.4/120
	16	1.5					3.2/200	4.2/170
	17	2.2						
	18	3.0						
3000	30	0.55	2.2/120	3.2/80	4.3/60	5.6/45	6.7/40	8.9/30
	31	0.75	2.2/160	3.2/110	4.3/80	5.6/65	6.7/55	8.9/40
	32	1.10	2.2/200	3.2/165	4.3/120	5.6/95	6.7/80	8.9/60
	33	1.50		3.2/200	4.3/165	5.6/130	6.7/110	8.9/80
	34	2.20			4.2/200	5.5/190	6.6/160	8.7/120
	35	3.00					6.4/200	8.5/170
Um./min	230 V	kW	$Q / p_n * [l/min] / [bar]$					
1500	5	0.55		1.6/165	2.1/125	2.7/100	3.2/80	4.3/60
	6	0.75		1.6/200	2.1/170	2.8/130	3.3/110	4.4/80
	7	1.10				2.8/190	3.3/160	4.4/120
	8	1.50					3.3/200	4.4/165
Code of the electric motor			36 P2..	44 P2..	48 P2..	58 P2..	62 P2..	79 P2..
	$p_{max.}^{**}$ [bar]		250			200		
R.P.M.	400 V	kW	$Q / p_n * [L/min] / [bar]$					
1500	13	0.55	4.5/60	5.5/50	6.0/45	7.3/35	7.8/35	9.9/25
	14	0.75	4.3/85	5.2/70	5.7/65	6.9/50	7.4/50	9.4/40
	15	1.10	4.8/110	5.8/90	6.3/85	7.7/70	8.2/65	10.4/50
	16	1.50	4.6/155	5.6/130	6.2/115	7.4/100	8.0/90	10.1/70
	17	2.20		5.0/200	5.5/190	6.6/160	7.1/150	9.0/120
	18	3.00			5.9/200	7.1/200	7.6/180	9.7/150
3000	30	0.55						
	31	0.75	9.7/35					
	32	1.10	9.7/55	11.8/45	12.9/40	15.6/35		
	33	1.50	9.7/75	11.8/60	12.9/55	15.6/45	16.7/40	
	34	2.20	9.5/110	11.6/90	12.7/85	15.3/70	16.4/65	20.9/50
	35	3.00	9.3/155	11.3/125	12.4/115	15.0/95	16.0/90	20.4/70
R.P.M.	230 V	kW	$Q / p_n * [L/min] / [bar]$					
1500	5	0.55	4.7/55	5.7/45	6.2/40	7.5/35	8.0/30	10.2/25
	6	0.75	4.8/75	5.9/60	6.4/55	7.7/45	8.3/45	10.5/35
	7	1.10	4.8/110	5.9/90	6.4/80	7.7/70	8.5/65	10.5/50
	8	1.50	4.8/150	5.9/120	6.4/110	7.7/95	8.5/85	10.5/70

* p_n - nominal pressure = the highest working pressure allowed without time restriction

** $p_{max.}$ - maximum pressure = maximum pressure allowed for a short time - max. 20s

Type of the Hydraulic Circuit

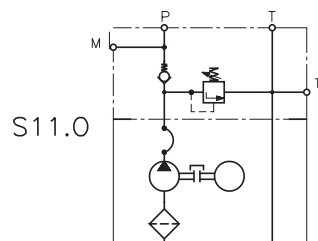

S11.0

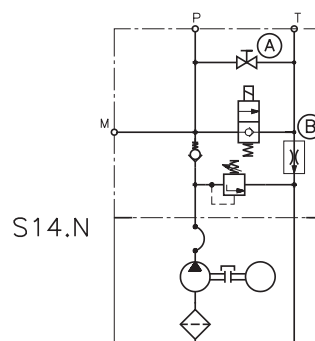

S14.N

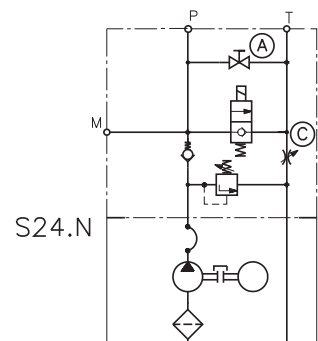

S24.N

The hydraulic circuit S11.0 enables the power pack to be used as a simple pressure supply for general applications with the possibility to build up additional hydraulic circuits in the form of horizontal stacking assemblies of the size 04 or 06. Should the power pack be run for longer time periods, it is necessary to take the load factor of the electric motor into account.

The hydraulic circuit S14.N and S24.N enable the power pack to be used as pressure supply for lifting platforms and other devices, in which the mass of the system provides returning into the basic position. The shuf-off valve (A) enables emergency lowering of the device, should a disconnection of the supply voltage occur.

The hydraulic circuit S14.N comprises a flow control valve VSK2 (B) which is adjustable only in a certain range (see catalogue VSK2 - HA 5121). The valve is accessible after removing the block from the tank cover. If not otherwise required, a valve VSK2 is mounted into the block. The stabilized flow rate of this valve corresponds with the respective flow rate of the power pack (see Tab. 1).

The hydraulic circuit S24.N comprises a throttle valve VSV1-06 (C) without pressure compensation. This valve is accessible from outside of the block.

Valve Dimensions

Dimensions in millimeters

Steel tank

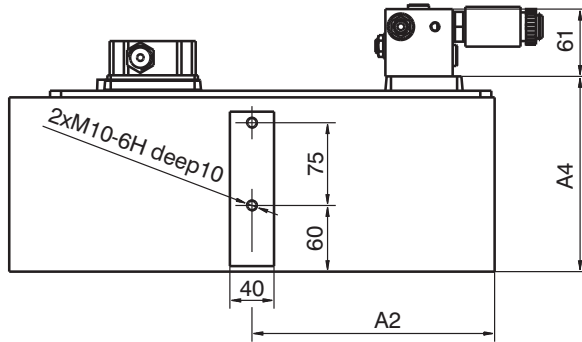

Throttle valve VSV1-06 (C)

Block S24.N

Block S14.N

Block S11

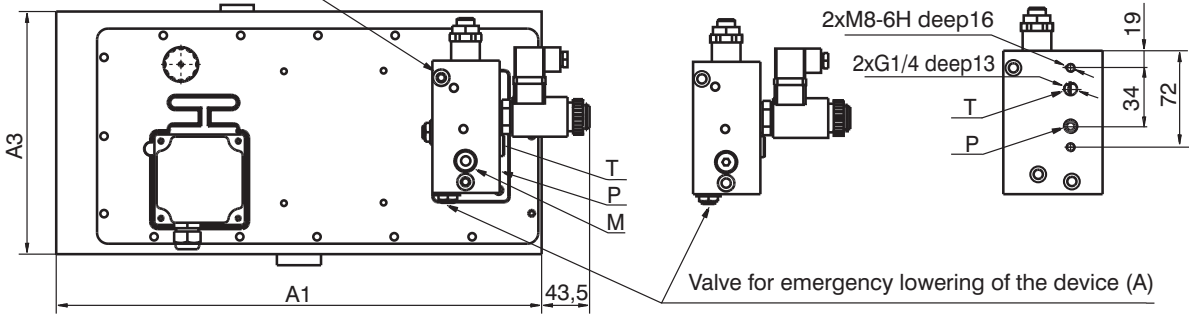

Example of horizontal stacking assembly

- possible only with hydraulic circuit S11.0

- E - according to the elements used, see datasheet 5021, 5023, 5051, 5093
- F - Size 04=40 mm
Size 06=50 mm
- G - Size 04=79 mm
Size 06=92 mm

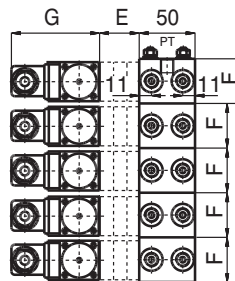

Code of the tank	Tank capacity in [L]	Working volume [L]	A1 [mm]	A2 [mm]	A3 [mm]	A4 [mm]
10 (steel)	10	6	440	220	220	175
20 (steel)	20	10	500	220	260	214
30 (steel)	30	20	500	220	260	294

7

Valve Dimensions

Dimensions in millimeters

Plastic tank

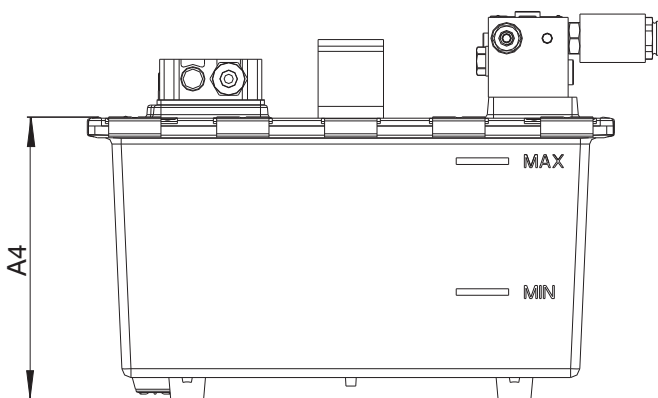

Throttle valve VSV1-06 (C)

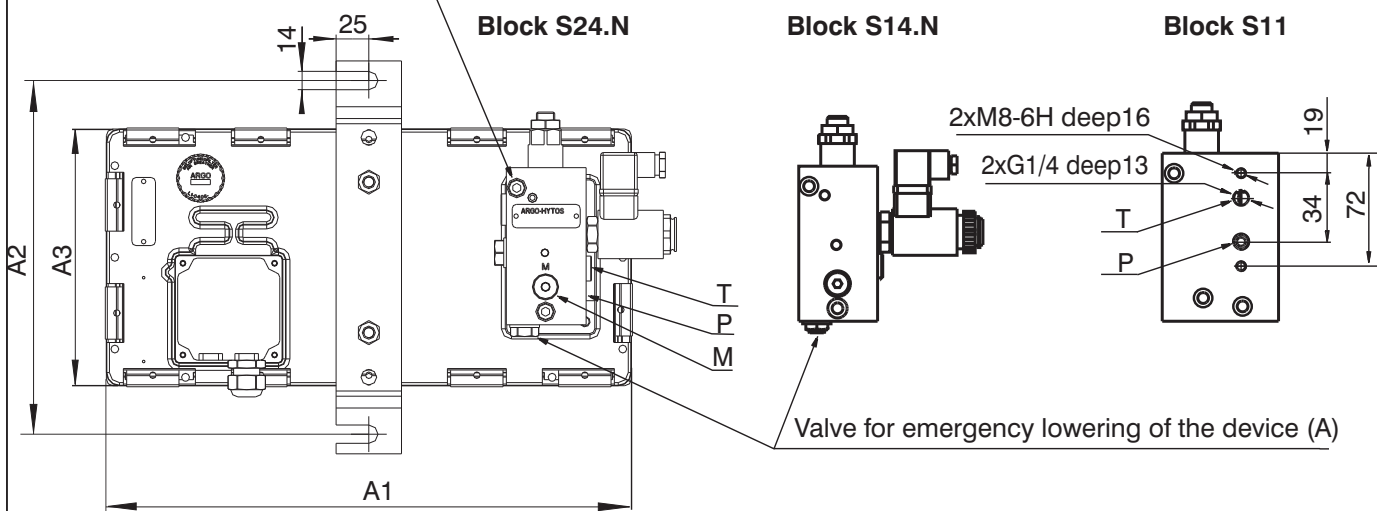

Code of the tank	Tank capacity in [L]	Working volume [L]	A1 [mm]	A2 [mm]	A3 [mm]	A4 [mm]
7 (plastic)	7	4	401	270	196	215

Caution!

- The packing foil is recyclable.
- The technical information regarding the product presented in this catalogue is for descriptive purposes only. It should not be construed in any case as a guaranteed representation of the product properties in the sense of the law.

ARGO-HYTOS s.r.o. CZ - 543 15 Vrchlabí
Tel.: +420-499-403111, Fax: +420-499-403421
E-mail: sales.cz@argo-hytos.com
www.argo-hytos.com

- Building of customized power packs using standardized sub assemblies
- Tank capacities from 10 to 250 L
- Systems with gear or piston pumps, wide range of flow rates with vertical layout and imersed pump
- Versatile pressure and flow control possibilities
- Enable building of hydraulic circuits as vertical or horizontal stacking assemblies
Connection of up to 8 horizontal sections possible
- Design and accessories according to customer specification

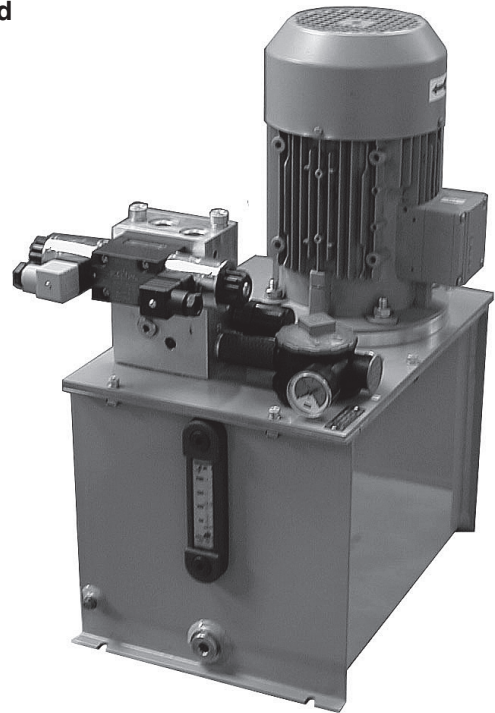

Functional Description

This technical information serves as a basic summary for building of hydraulic power packs designed of standezedized sub-assemblies. Table 1 enables selection of the required combination (tank capacity, type of pump, flow rate, pressure, size of the electric motor, type of pressure control etc.).If you cannot find the required solution using the components shown below, please consult us. We can offer special tanks, remote control of components, drives with double pumps, special connection of componets etc. On request, also the separate components can be delivered. A questionnaire, which is enclosed to this information, also the should help you to specify your requirements. Please enclose also the respective circuit diagram, the required installation dimensions, as well as the size and orientation of connecting ports.

So as we can offer you a power pack, which will comply completely with your requirements, we need exact information about your system.

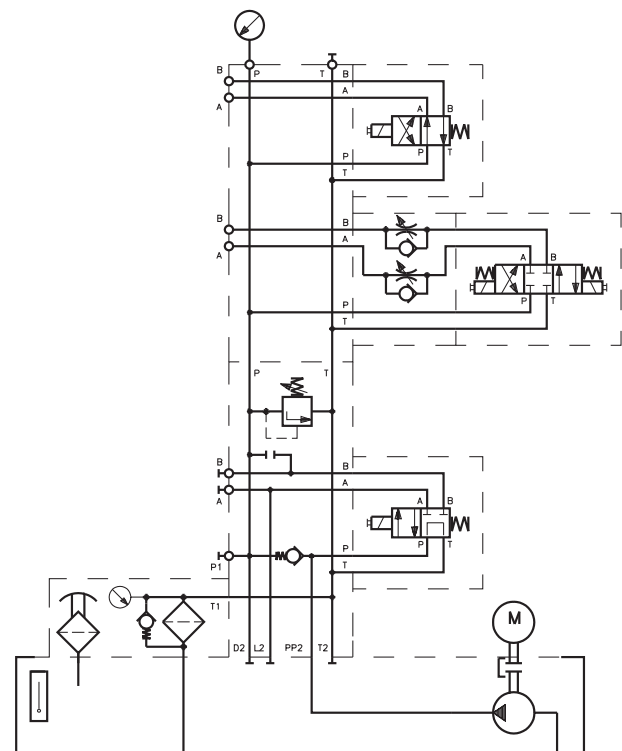

SA4

- 1 Tank
- 2 Drive/ Bell housing
- 3 Pump
- 4 Electric motor
- 5 Base block (safety block of the accumulator)
- 6 Horizontal stacking assembly
- 7 Vertical stacking assembly
- 8 Pressure gauge
- 9 Return filter with by-pass, integrated air breather/filler and clogging indicator
- 10 Continuous level gauge
- 11 Magnetic drain plug
- 12 Earthing point

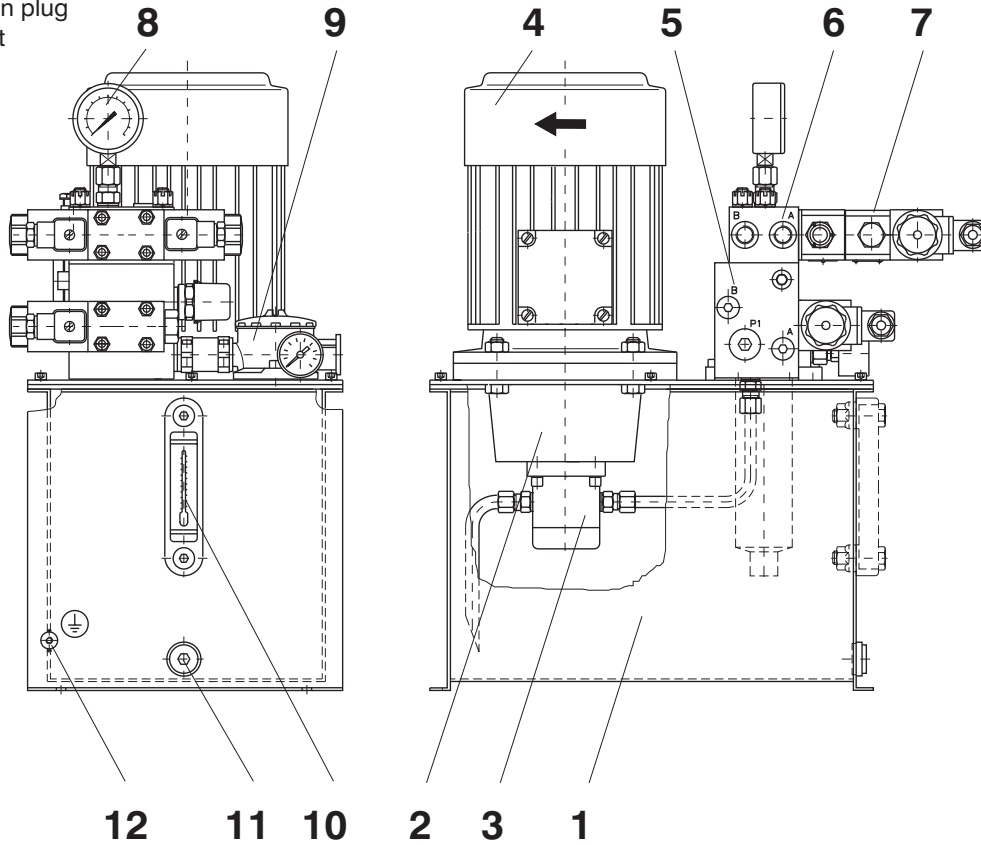
**Tab. 1**

Type of the power pack	Tank capacity [L]	Type of the pump	Flow rate [L/min]	Working pressure [bar]	Size of the electric motor	Q/p Table No.	Type of the control
SA4-10C	10	gear pump	0.5 - 10.5	250	80, 90	3	14
SA4-20C	20	gear pump	0.5 - 21.8	250	80, 90, 100, 112	3	14, 16
SA4-30C	30	gear pump	1.9 - 23.6	250	80, 90, 100, 112	2 - 3	14, 15, 16
SA4-40C	40	gear pump	1.9 - 23.6	250	80, 90, 100, 112	2 - 3	14, 15, 16
SA4-45U	45	gear pump	1.9 - 23.6	250	80, 90, 100, 112	2 - 3	14, 15, 16
SA4-60H	60	gear pump	6 - 36	250	80, 90, 100, 112, 132	2 - 4	14, 15, 16, 18
		variable piston pump	up to 29			5	17
SA4-60U	60	gear pump	6 - 36	250	80, 90, 100, 112, 132	2 - 4	14, 15, 16, 18
		variable piston pump	up to 29			5	17
SA4-100H	100	gear pump	6 - 42	250	90, 100, 112, 132	2 - 4	14, 15, 16, 18
		variable piston pump	up to 29			5	17
SA4-250H	250	gear pump	up to 50	250	80, 90, 100, 112, 132	2 - 4	14, 15, 16, 18
		variable piston pump	up to 50			5	17

Design of the Power Pack from the Standardized Sub-assemblies

1 Location

Clear description of the working environment of the power pack.

2 Working conditions

Stating of the power pack working cycle (service character).

3 Working pressure p [bar]

Pressure which is necessary to ensure the required forces and torques.

4 Flow rate Q [L/min]

Flow rate which is necessary to ensure the required velocities and revolutions.

5 Type of the pump

To be determined after evaluation of the points mentioned above.

The following pumps are available: - gear pumps
- variable piston pumps

6 Pump displacement

See point 7.

7 Electric motor

By the use of table 1 and 2 to 5 and according to the required flow rate and pressure, the respective displacement of the pump, as well as the power and revolutions of the electric motor are to be determined. These data are to be put down into the questionnaire, together with the information regarding the network voltage and frequency, type of enclosure, climatic endurance etc.

The tables also include the basic drive dimensions - diameter of the flange and the total height of the electric motor including the flange thickness or the thickness of the damping ring (Fig. 2 and 3). The damping rubber ring is normally delivered with the drives with the variable piston pump. On request, it can also be delivered with the gear pumps.

8 Lay out of the drive

Vertical - with all types of gear pumps and with axial piston pumps with pressure control (Fig. 2 and 3).

Horizontal - only for special applications and after consultation with us.

Fig. 2

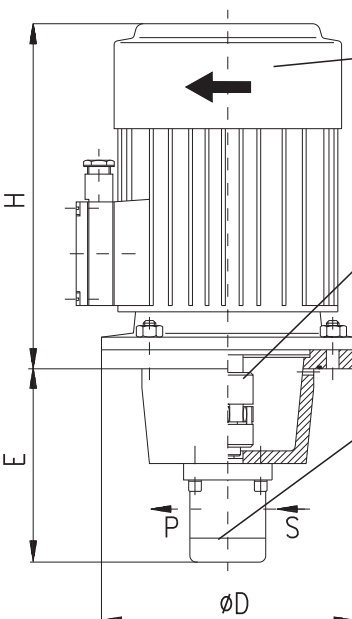
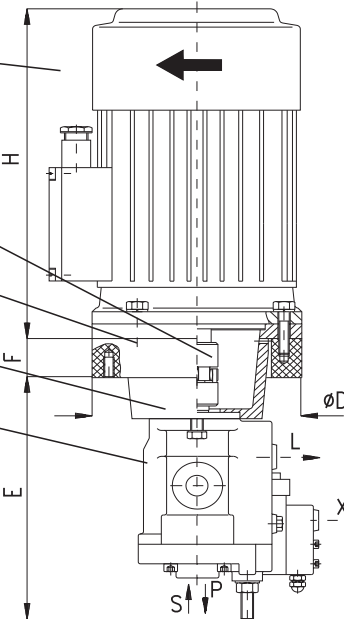
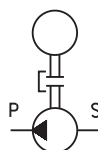

Fig. 3



- 1 Electric motor
- 2 Gear pump
- 3 Variable piston pump
- 4 Flange
- 5 Coupling
- 6 Damping rubber ring

- S - suction line
- P - pressure line
- L - leakage
- X - control



The screw for pump geometric volume setting.*

- L 25C 1,20 [cm³.ot⁻¹] screw
- K 38C 1,81 [cm³.ot⁻¹] screw

Tab. 2a Gear Pumps Size 1 - Series P23

Data of the electric motor			Displacement of the pump [cm ³]												Dimension of the drive		
			0,8		1,2		1,6		2,1		2,5		3,3				
Size	n [min ⁻¹]	p [kW]	Q/p [L/min]/[bar]												∅ D [mm]	H [mm]	E max. [mm]
80	1395	0.55	1.1	200	1.6	170	2.1	125	2.8	95	3.3	80	4.4	60	200	248	174
80	1395	0.75			1.6	200	2.1	170	2.8	130	3.3	110	4.4	80	200	248	174
90	1410	1.10					2.1	200	2.8	190	3.3	160	4.4	120	200	296	174
90	1410	1.50							2.8	200	3.3	200	4.4	165	200	296	174
100	1420	2.20											4.4	200	250	328	192
100	1420	3.00															
71	2790	0.55	2.1	125	3.1	85	4.2	60	5.6	45	6.6	40	8.7	30	160	225	157
80	2850	0.75	2.2	165	3.2	110	4.3	85	5.7	65	6.8	55	8.9	40	200	248	174
80	2835	1.10	2.2	200	3.2	160	4.3	125	5.7	95	6.7	80	8.9	60	200	248	174
90	2860	1.50			3.2	200	4.3	165	5.7	125	6.8	105	9.0	80	200	296	174
90	2850	2.20					4.3	200	5.7	185	6.8	155	8.9	120	200	296	174
100	2895	3.00											9.1	160	250	328	192

Tab. 2b Gear Pumps Size 1 - Series P23

Data of the electric motor			Displacement of the pump [cm ³]												Dimension of the drive		
			3,6		4,4		4,8		5,8		6,2		7,9				
Size	n [min ⁻¹]	p [kW]	Q/p [L/min]/[bar]												∅ D [mm]	H [mm]	E max. [mm]
80	1395	0.55	4.8	55	5.8	45	6.4	40	7.7	35	8.2	30	10.5	25	200	248	174
80	1395	0.75	4.8	75	5.8	60	6.4	55	7.7	45	8.2	45	10.5	35	200	248	174
90	1410	1.10	4.8	110	5.9	90	6.4	80	7.8	70	8.3	65	10.6	50	200	296	174
90	1410	1.50	4.8	150	5.9	120	6.4	110	7.8	95	8.3	85	10.6	70	200	296	174
100	1420	2.20	4.8	200	5.9	180	6.5	165	7.8	135	8.4	125	10.7	100	250	328	192
100	1420	3.00			5.9	200	6.5	200	7.8	160	8.4	160	10.7	135	250	328	192
71	2790	0.55	9.5	30	11.7	25	12.7	20	15.4	20	16.4	15	20.9	15	160	225	157
80	2850	0.75	9.7	35	11.9	30	13.0	30	15.7	25	16.8	20	21.4	15	200	248	174
80	2835	1.10	9.7	55	11.9	45	12.9	40	15.6	35	16.7	30	21.3	25	200	248	174
90	2860	1.50	9.7	75	11.9	60	13.0	55	15.8	45	16.8	45	21.5	35	200	296	174
90	2850	2.20	9.7	110	11.9	90	13.0	80	15.7	65	16.8	65	21.4	50	200	296	174
100	2895	3.00	9.9	145	12.0	120	13.2	110	16.0	90	17.1	85	21.7	65	250	328	192

Tab. 3a Gear Pumps Size 2 - Series T2

Data of the electric motor			Displacement of the pump [cm ³]												Dimension of the drive		
			4		5		6,3		8		10						
Size	n [min ⁻¹]	p [kW]	Q/p [L/min]/[bar]												∅ D [mm]	H [mm]	E max. [mm]
90	1410	1.1	5.4	100	6.7	80	8.5	65	10.8	50	13.5	40	200	296	222		
90	1410	1.5	5.4	135	6.7	110	8.5	85	10.8	65	13.5	55	200	296	222		
100	1420	2.2	5.4	195	6.7	155	8.5	125	10.8	100	13.5	80	250	328	228		
100	1420	3.0	5.4	270	6.7	215	8.5	170	10.8	135	13.5	105	250	328	228		
112	1440	4.0			6.8	270	8.6	225	11.0	175	13.8	140	250	348	228		
132	1455	5.5							11.0	240	13.8	190	300	389	248		
132	1455	7.5									13.8	250	300	389	248		

Tab. 3b Gear Pumps Size 2 - Series T2

Data of the electric motor			Displacement of the pump [cm ³]												Dimension of the drive		
			12,5		16		20		25								
Size	n [min ⁻¹]	p [kW]	Q/p [L/min]/[bar]												∅ D [mm]	H [mm]	E max. [mm]
90	1410	1.1	16.9	30	21.6	25	27.0	20	33.7	15	200	296	222				
90	1410	1.5	16.9	45	21.6	35	27.0	25	33.7	20	200	296	222				
100	1420	2.2	16.9	65	21.6	50	27.0	40	33.7	30	250	328	228				
100	1420	3.0	16.9	85	21.6	65	27.5	55	33.7	45	250	328	228				
112	1440	4.0	17.3	110	22.1	90	27.5	70	34.6	55	250	348	228				
132	1455	5.5	17.3	155	22.1	120	27.5	95	34.6	75	300	389	248				
132	1455	7.5	17.3	210	22.1	165	27.5	130	34.6	105	300	389	248				

Tab. 4 Gear Pumps Size 3 - Series Q

Data of the electric motor			Displacement of the pump [cm ³]								Dimension of the drive		
			10		17		27		34				
Size	n [min ⁻¹]	p [kW]	Q/p [L/min]/[bar]								∅ D [mm]	H [mm]	E max. [mm]
100	1420	3.0	13.5	105	22.9	65	36.9	40	45.9	30	250	328	255
112	1440	4.0	13.8	140	23.3	85	36.9	50	46.5	40	250	348	255
132	1455	5.5	13.8	190	23.5	110	37.3	70	47.0	55	300	389	275
132	1455	7.5			23.5	155	37.3	95	47.0	75	300	389	275

Tab. 5 Variable Pistons Pumps

Data of the electric motor			Maximum geometric volume of pump [cm ³]				Dimension of the drive			L25C	K38C
			L25C		K38C						
			*25		*38						
Size	n [min ⁻¹]	p [kW]	max. Q/p [L/min]/[bar]				∅ D [mm]	H [mm]	F [mm]	E max. [mm]	E max. [mm]
100	1420	2.2	33.7	35			250	328	45	296	
100	1420	3.0	33.7	50			250	328	45	296	
112	1440	4.0	34.1	65			250	348	45	296	
132	1455	5.5	34.1	90	52.5	55	300	389	50	296	313
132	1455	7.5	34.1	120	52.5	75	300	389	50	296	313

* Maximum geometric volume of pump is adjusted with setting screw (see.Pic No.3)
 L 25C 1,20 [cm³. ot⁻¹](screw), K 38C 1,81 [cm³. ot⁻¹](screw)

9 Tank capacity

The following are our recommendation as to determination of the capacity:

- hydraulic circuits with fixed pumps - from 3 up to 6 multiple of the pump flow rate [L/min].
- hydraulic circuits with variable pumps - from 2 up to 4 multiple of the pump flow rate [L/min]

Tanks normally delivered:

Fig. 4
Tank models 10C, 20C, 30C, 40C

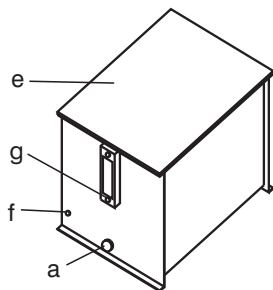

Fig. 5
Tank models 45U, 60U

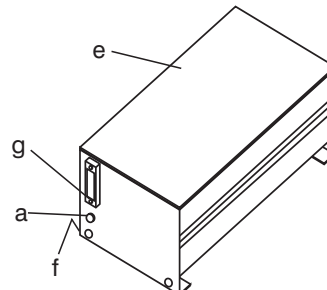
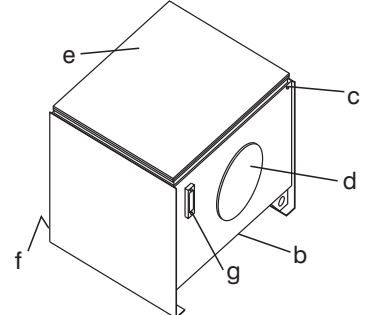

Fig. 6
Tank models 60H, 100H, 250H



Parts delivered with a tank (Fig.4, 5, 6):

- a) Drain plug on the front side of the tank - with capacities 10H, 20H, 30H, 40H, 45U, 60U
- b) Drain plug on the bottom of the tank - with capacities 60H, 100H, 250H
- c) Leakage drain plug on the through collector at the upper side of the tank - with capacities 60H, 100H, 250H
- d) Cleaning cover on the side of the tank - with capacities 60H, 100H, 250H
- e) Bolt mounted cover sealad against dust penetration
- f) Earthing bolt
- g) Continuous level gauge

Fig. 7

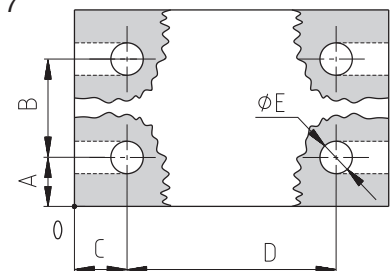

Tank designation	Tank capacity [L]	Tank dimension Length x width x height [mm]	Dimensions of fix slots [mm] (Fig. 7)				
			A	B	C	D	∅ E
10C	10	400 x 280 x 186	30	220	6	388	9 (slot)
20C	20	400 x 280 x 274	30	220	6	388	9 (slot)
30C	30	500 x 320 x 285	30	260	10,5	479	11 (slot)
40C	40	500 x 320 x 364	30	260	10,5	479	11 (slot)
45U	45	700 x 370 x 329	35	300	25	650	11
60U	60	700 x 370 x 394	35	300	25	650	11
60H	60	600 x 470 x 485	35	400	30	540	14
100H	100	700 x 550 x 565	25	500	30	640	14
250H	250	1006 x 610 x 680	20	570	47	912	14

10 Painting

The following are the standard paintings of the outside surface of the tank:

- top coat - RAL 7030 KOMAXIT (stone gray)
 - aluminum parts - without surface treatment
 - hydraulic components - manufacturer's standard painting
- Other paints or special surface treatment on request.

Component assembly on the tank cover

In addition to drive unit, also the base block and filtering unit are usually situated on the tank cover. The base block is connected to the pump output. It comprises a check valve and pressure valve (or some other components) according to the pressure control system used (see the circuit diagrams in Fig. 14 to 18). It also enables other components of the hydraulic circuit to be connected, e.g.:

- oil filter
- subplates or connecting plates with the respective components
- accumulator

11 Pressure control

- **Pressure relief valve VT** (Fig. 14) - used with all types of gear pumps.
- **Unloading valve VO** (Fig. 15) - used in combination of a gear pump, an accumulator and a check valve. When the pressure set at the unloading valve is reached, the valve loads the pump. The accumulator provides for holding the pressure in the circuit behind the check valve. Pressure valve VP works as the safety valve of the accumulator.
- **Switching** (Fig. 16) - used in combination of a gear pump, an accumulator, a check valve and pressure switch **TS**. When the pressure in the system reaches the pressure set at the pressure switch, the respective circuit switches off the electric motor. The accumulator provides for holding the pressure in the circuit behind the check valve. Pressure valve VP works as the safety valve of the accumulator.
- **Remote control with the pressure relief valve VT** (Fig. 17) - used only with piston pumps with pressure control. Pressure valve VP protects the circuits against pressure peaks.
- Pressure valve on the pump - used with piston pumps with pressure control. Pressure is adjusted by means of the screw which is fixed to the pump. Pressure valve VP protects the circuit against pressure peaks.

12 Oil filtration

Preferably the return filters with visual (Fig. 8) or electric (Fig. 9) clogging indication are used. These filters can also be used (after removing the cover) as the filling filters. They usually also comprise an integrated air breather.

Fig. 8

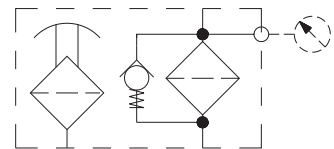
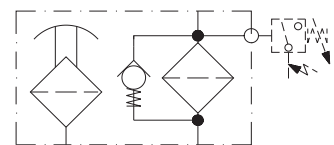

Fig. 9



Type of the filter	Type of the insert	Flow rate [L/min]	By-pass Δp [bar]	Absolute filtration [μm]
FR 043 - 166	V3 . 0510 - 56	25	2.5	10
FR 072 - 166	V3 . 0520 - 56	50	2.5	10
E 103 - 676	V3 . 0620 - 56	75	2.5	10

13 Size of the components

The hydraulic components are assembled into a hydraulic circuit by means of connecting or modular plates PD06 (catalogue HA 0006). These plates enable building of hydraulic systems as horizontal or vertical stacking assemblies representing compact system without connecting pipes or hoses. Up to 8 section can be connected in a horizontal stacking assembly. The installation dimension of the components size 06 correspond with ISO 4401- Ab-03-4 and DIN 24340-A6.

The working ports are provided with pipe threads as follows:

- a) base block type ZB 06 x - xx
 - A, B - G3/8"
 - P, P1, T - G1/2"
- b) in-line modular plates PD 06 xx - AL
 - A, B, P - G3/8"
 - T - G1/2"

14 Control voltage

of the electro-hydraulic components used must be determined with regard to the safety and protection of health. On request, the components with the following Dc control voltages can be delivered: 12, 14, 21, 24, 42, 48, 60, 102 and 205 V. The available Ac voltages are 24, 115 and 230V / 50 (60)Hz.

15 Accumulators

The gas bar or membrane accumulators are being used (Fig. 10). The required capacity in L is to be determined. Preferably the accumulators from those suppliers are being used, who can ensure the international certification (**at least the certification from the German Testing Laboratory TÜV**).

When filling in the wrong again, please give the country in which your machine with our power pack is going to be used. The accumulator is a pressure tank which must comply with the regulations regarding the safety of work. These regulations differ in the particular countries. The accumulator must be provided with the certificate of the respective country it is going to be used in!

Smaller accumulators (up to 4 L) are mounted directly onto the cover of the tank or onto a short block (max. with 2 sections of control components above the base block). Larger larger accumulators are mounted only onto the tank cover. Together with an accumulator also the filling and checking equipment can be delivered (including the pressure gauge for filling the accumulator with nitrogen).

We recommend the use of the accumulator to be discussed with our technicians.

Fig. 10

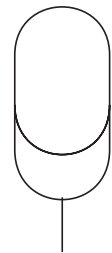

16 Accumulator block

The function of the safety block is provided by the base block (see Fig. 15 and 16). The use of another block is to be consulted with us.

17, 18 Thermometer, thermostat, oil level transducer

These instruments can be mounted onto the tank cover. The **thermometer** (Fig. 11) and the **thermostat** (Fig. 12) provide for checking the oil temperature. The **oil level transducer** (Fig. 13).

Fig. 11

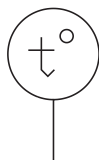

Fig. 12

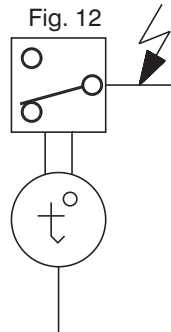
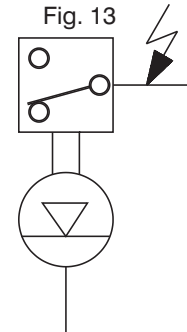

Fig. 13



19 Electric equipment

Power packs delivered without electric equipment are standard. The electric circuit diagram of the electric motor is on the lower side of the cover of the motor terminal box. On request, the electric boxes (including terminals, circuits breakers etc.) can be delivered.

20 Hydraulic fluid

The hydraulic power packs are designed to operate with mineral oils of the power classes HM and HV according to the European specification CETOP RP 91 H and with the bio-degradable hydraulic fluids of the groups HTG and HE according to DIN-proposal.

21 Special equipment

Special requirements regarding the power pack equipment, such as oil cooling and heating, power pack covering etc., are to be consulted with our technicians.

Fig. 14

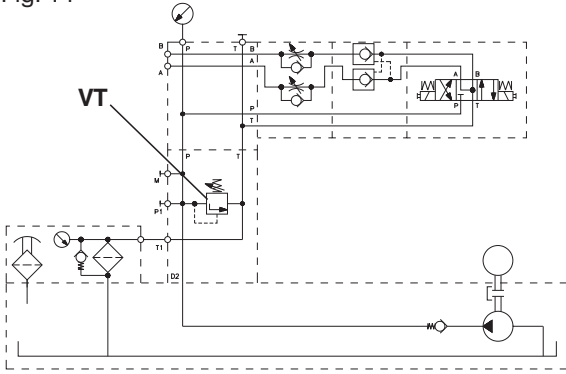

Power pack with gear pump - pressure in hydraulic system is controlled by pressure relief valve VT. (usable with tank capacities)

Fig. 15

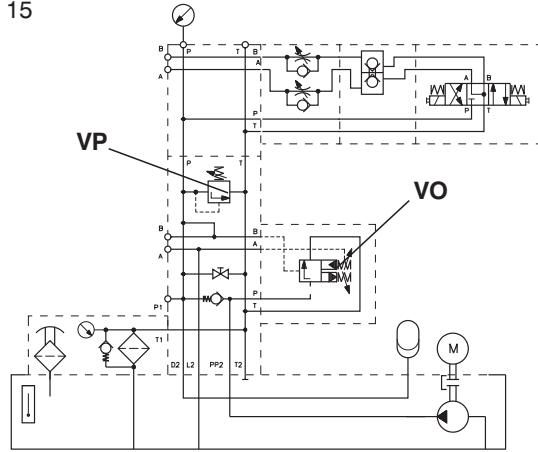

Power pack with gear pump - pressure in the system held by accumulator and check valve, pump pressure unloaded through unloading valve VO. Pressure relief valve VP works as the safety valve of the accumulator (for tank capacities from 40 up to 250 L and accumulators capacities from 2.5 up to 10 L).

Fig. 16

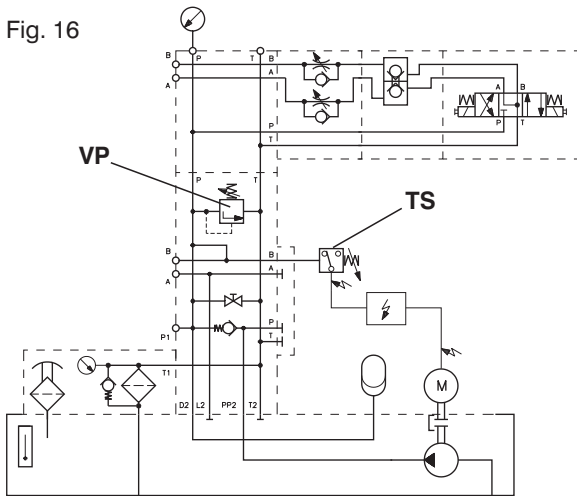

Power pack with gear pump and pressure switch TS controlling the switching-off of the electric motor. Pressure relief valve VP works as the safety valve of the accumulator (for tank capacities from 20 up to 60 L and accumulators capacities from 2.5 up to 10 L).

Fig. 17

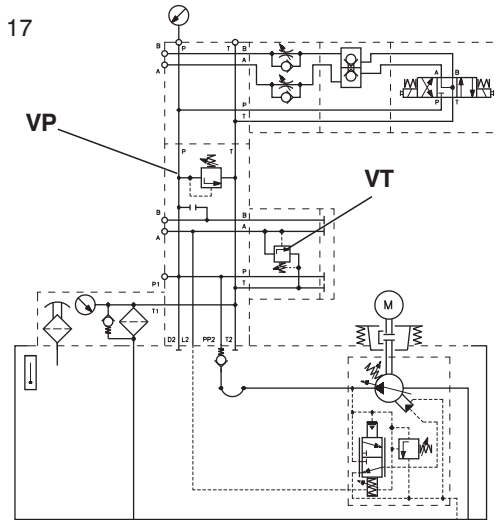

Power pack with piston pump with pressure control - remote pressure control through pressure relief valve VT. Pressure relief valve VP protects the system against pressure peaks (for tank capacities from 60 up to 250 L).

Fig. 10

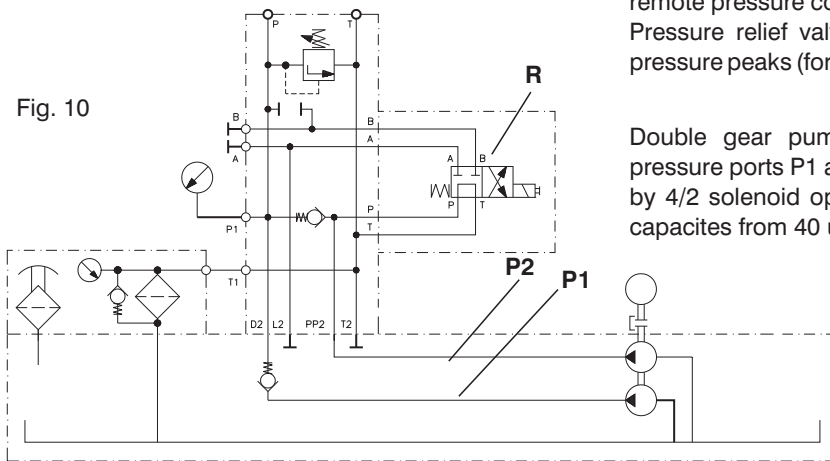

Double gear pump hydraulic power unit with two pressure ports P1 and P2. P2 pressure port is unloaded by 4/2 solenoid operated directional valve R (for tank capacities from 40 up to 250 L).

Caution!

- The packing foil is recyclable.
- The technical information regarding the product presented in this catalogue is for descriptive purposes only. It should not be construed in any case as a guaranteed representation of the product properties in the sense of the law.

ARGO-HYTOS s.r.o. CZ - 543 15 Vrchlaví
 Tel.: +420-499-403111, Fax: +420-499-403421
 E-mail: sales.cz@argo-hytos.com
 www.argo-hytos.com

- Compact power packs for the use in lifting platforms, elevating tables, ramps, presses, machine tools, mobile applications and others
- 5 basic hydraulic circuits in the manifold
- Possibility of building up an additional circuit in the form of vertical or horizontal stacking assembly
- Tank capacities from 1.5 to 40L
- Low noise level

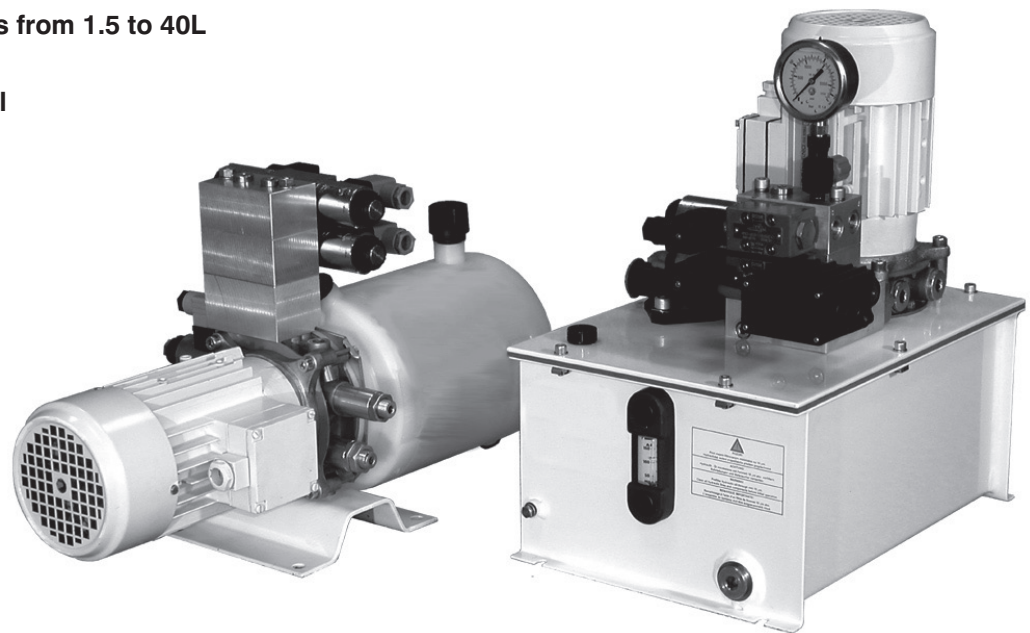

Functional Description

Compact hydraulic power packs are designed to fit into small envelope dimensions and can be used in lifting platforms, elevating tables, manipulators, small presses, machine tools and mobile applications.

Each power pack consists of an electric motor, a pump, a manifold and a tank. The aluminum body forms the base of the power pack, on which all the main components, including the hydraulic elements, are mounted. The function of the power packs is apparent from the respective hydraulic circuit diagrams. The desired combination of particular components and hydraulic elements can be defined by reference to the ordering code and the respective tables.

The hydraulic circuits can be accomplished in sizes 03, 04 and 06. The size 03 is in a form of sectional directional valves, and does not enable any extension by valves for

controlling the flow rate and the pressure.

The mounting position of the power pack is horizontal or vertical - see the Power Pack Dimensions on pages 11 to 17. All ports have G 1/4 internal threads (the thread G3/8 is to be agreed with manufacturer).

With the standard model the connecting ports A, B of the components of the vertical stacking assembly are oriented onto one side. Orientation of ports A, B each onto another side is to be agreed with the manufacturer.

The basic combinations of electric motors and pumps, as well as their code designations, are shown in tables 1, 2 and 3.

Information regarding the basic power pack surface treatment is on page 3.

Ordering Code

SMA 05-□ / □ . □ - □ - □ □ . □ - □ □ □ / □

Compact Power Pack

Pump displacement in cm³

Series X	Series P
0.32 03	0.8 08
0.40 04	1.2 12
0.50 05	1.6 16
0.63 06	2.1 21
	2.5 25
	3.3 33
	3.6 36
	4.4 44
	4.8 48
	5.8 58
	6.2 62
	7.9 79

Code of the electric motor (see tables 1, 2 and 3)

DC electric motor with switch **R**

Single-phase electric motor without starting module **O**
with starting module **M**

Three-phase electric motor **O**

Type of hydraulic circuit see table on pages 7 and 8

Tank code see pages 11 - 16

Solenoid voltage

01200	12V DC
02400	24V DC
20500	205V DC
23050	230V / 50 (60)Hz

Nominal size of stacking assembly elements

0	Without stacking assembly
3	Size 03
4	Size 04
6	Size 06

(see page 12)

Number of add-on units

0	Without stacking assembly
1	1 Section
2	2 Sections
3	3 Sections
4	4 Sections
5	5 Sections

(see page 12)

Type of stacking assembly

0	Without stacking assembly
A	Configuration A
B	Configuration B
C	Configuration C
D	Configuration D
E	Configuration E
F	Configuration F

(see page 12)

Foot bracket

O	without foot bracket
F	low foot bracket
K	high holder (for tank codes 40 - 45 only)

Type of filter used

O	without filter
S	suction filter
R*	return line filter without indication
E*	return line filter with el. indication
M*	return line filter with manometer

* for tank codes 56 - 60 only

7

Technical Data

Flow rate	L/min	to tables 1, 2 and 3		
Working pressure	bar	to tables 1, 2 and 3		
Tank capacity	L	1.5 - 40		
Type of pump		external gear pump, left-hand rotation		
Nominal pressure / max. pressure	bar	to tables 1, 2		
Power of electric motor		to tables 1, 2 and 3		
Type of electric motor		single phase	three phase	DC
Voltage of the electric motor	V	230	230/400	12/24
Frequency	Hz	50	50	-
Electric motor enclosure type / insulation class		IP 55/F	IP 55/F	IP 43/F
Voltage of directional valves	V	12DC, 24DC, 205DC, 230AC		
Hydraulic fluid		Hydraulic oils of power classes (HL, HLP) to DIN 51 524		
Oil Conductivity	pS/m	≥ 500 on 20° C		
Viscosity range	mm ² /s	20 ... 100		
Max. degree of fluid contamination		Class 21/18/15 to ISO 4406 (1999).		
Filtration (suction/return/)	µm	60/12		
Fluid temperature range	°C	0 ... +70		
Fluid temperature range for a short term 10 minute max.	°C	-20 minimum +80 maximum		
Ambient temperature range	°C	-25 ... +50		
Thread of the connectiong ports P, T, A, B, M		G1/4 (A, B G3/8 - per request)		
Working position		horizontal, vertical		

Standard Surface Treatment

Model	Material used	Surface treatment
Cylindrical sheet tank	Sheet steel	Komaxit RAL 7030
Square sheet tank/cover	Sheet steel	Komaxit RAL 7030
Cylindrical plastic tank	BOREALIS ME 8131 (transparent)	Without surface treatment
Square plastic tank	MOSTEN (transparent)	Without surface treatment
DC electric motor		Zinc coated
AC electric motor		RAL 7030
Other components to manufacturer standard		

Other surface treatment - is to agreed with manufacturer.

Tab. 2a

Code of the single-phase motors			Code of the pump																												
			03 X-...				04 X-...				05 X-...				06 X-...				08 P2-...				12 P2-...				16 P2-...				21 P2-...
p _{max.} ** [bar]			240												250																
230V	n[1/min]	p[kW]	Q/p _{n.} * [L/min] / [bar]																												
1	1300	0,12	0,3	160	0,4	125	0,6	100	0,7	80	0,9	65	1,3	40	1,8	30															
2	1350	0,18	0,4	200	0,4	185	0,6	150	0,7	115	0,9	90	1,4	60	1,9	45	2,5	35													
3	1390	0,25			0,5	250	0,6	200	0,8	160	0,9	125	1,4	80	1,9	60	2,6	45													
4	1410	0,37							0,8	200	0,9	180	1,4	120	1,9	90	2,6	70													
5	1370	0,55									0,9	200	1,4	180	1,9	135	2,6	105													
6	1410	0,75											1,5	200	2,0	180	2,6	140													
7	1410	1,10															2,6	200													
8	1410	1,50																													
19	2840	0,18	0,7	110	0,9	90	1,2	70	1,5	55	1,9	45	2,9	30																	
20	2840	0,25	0,7	155	0,9	125	1,2	100	1,5	80	1,9	60	2,9	40	3,9	30															
21	2780	0,37	0,7	200	0,9	185	1,2	150	1,5	120	1,9	90	2,9	60	3,9	45	5,2	35													
22	2820	0,55					1,2	200	1,5	175	1,9	135	2,9	90	3,9	65	5,3	50													
23	2820	0,75							1,5	200	1,9	185	2,9	120	3,9	90	5,3	70													
24	2845	1,10									1,9	200	2,9	175	4,0	130	5,3	100													
25	2855	1,50											2,9	200	4,0	175	5,3	135													
26	2810	2,20															5,3	200													

Tab. 2b

Code of the single-phase motors			Code of the pump																												
			25 P2-...				33 P2-...				36 P2-...				44 P2-...				48 P2-...				58 P2-...				62 P2-...				79 P2-...
p _{max.} ** [bar]			250												200								160								
230V	n[1/min]	p[kW]	Q/p _{n.} * [L/min] / [bar]																												
1	1300	0,12																													
2	1350	0,18	3,1	30																											
3	1390	0,25	3,1	40	4,2	30	4,6	30																							
4	1410	0,37	3,1	55	4,2	45	4,6	40	5,6	30	6,1	30	7,4	25																	
5	1370	0,55	3,1	85	4,2	65	4,6	60	5,6	50	6,1	45	7,4	35	7,8	35	10,0	30													
6	1410	0,75	3,2	115	4,3	85	4,7	80	5,7	65	6,2	60	7,5	50	8,0	45	10,2	35													
7	1410	1,10	3,2	165	4,3	130	4,7	115	5,7	95	6,2	90	7,5	75	8,0	70	10,2	55													
8	1410	1,50	3,2	200	4,3	175	4,7	160	5,7	130	6,2	120	7,5	100	8,0	95	10,2	75													
19	2840	0,18																													
20	2840	0,25																													
21	2780	0,37	6,3	30																											
22	2820	0,55	6,4	40	8,6	30	9,3	30																							
23	2820	0,75	6,4	55	8,6	45	9,3	40	11,4	35	12,5	30	15,0	25																	
24	2845	1,10	6,5	85	8,6	65	9,4	60	11,5	50	12,5	45	15,1	35	16,2	35															
25	2855	1,50	6,5	110	8,6	85	9,4	80	11,5	65	12,5	60	15,1	50	16,2	45															
26	2810	2,20	6,5	165	8,6	130	9,4	120	11,5	95	12,5	90	15,1	75	16,1	70															

Attention! Pay special attention to the start-up torque of single-phase motors. Use the start-up module during start-up under pressure.

* p_{n.} - nominal pressure = the highest working pressure allowed without time restriction

** p_{max.} - maximum pressure = maximum pressure allowed for a short time - max. 20s

Tab. 3

12V	24V	kW	Code of the pump 40 - 63
Code of the electric motor			Q [L/min] / p [bar]
40	/	0,35	See characteristics on page 6
45	/	0,8	
/	46	1,2	
51	/	1,5	
/	52	2,0	
/	63	3,0	

Attention! The DC motors must be loaded, so as to reduce the revolutions! Do not run the motors without pressure loading!

Characteristics

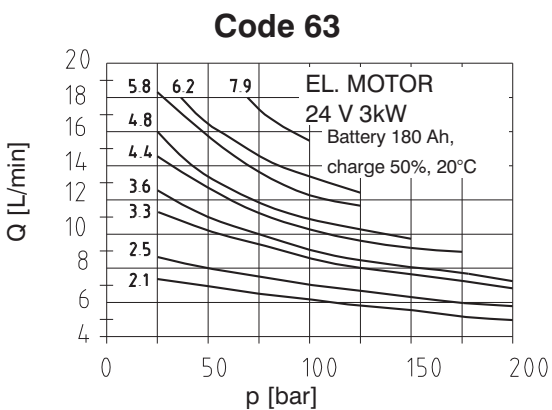
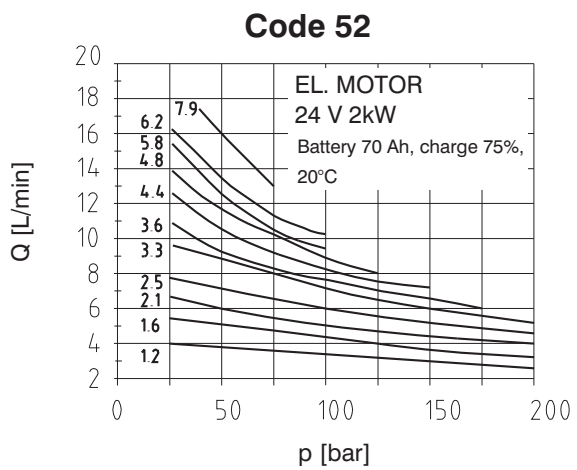
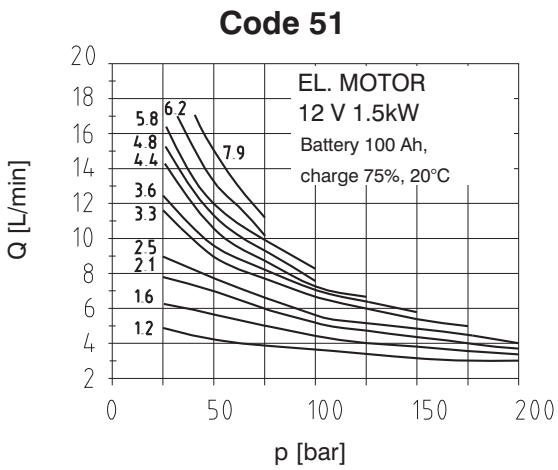
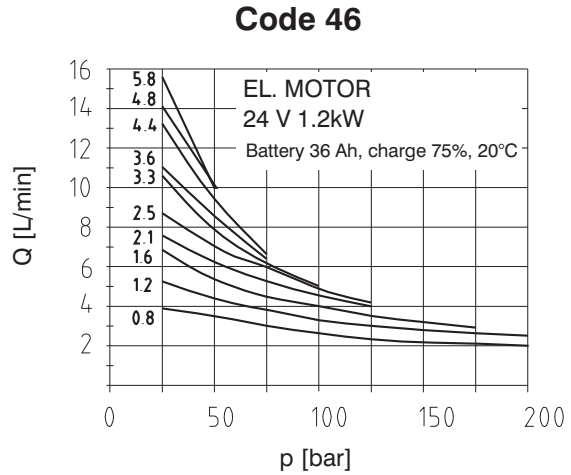
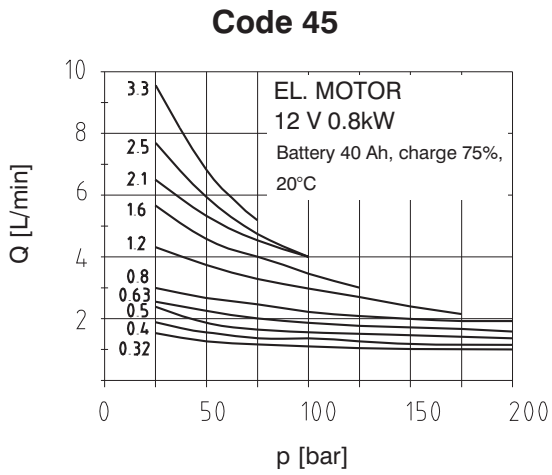
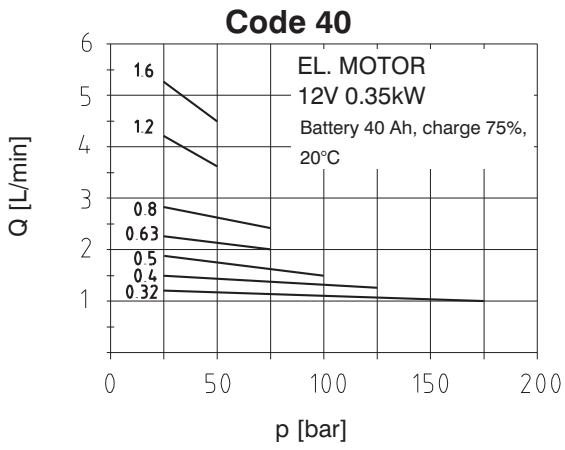

7

Basic Hydraulic Circuit Diagrams

A

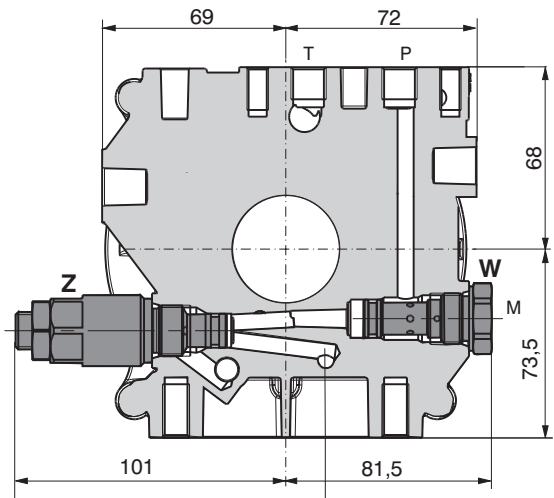
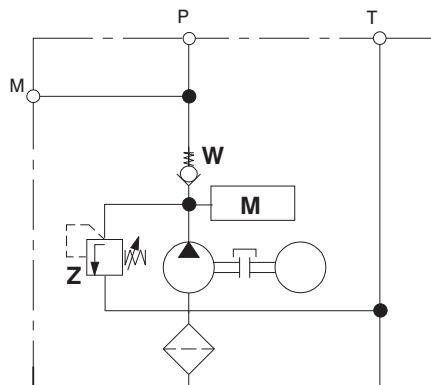

Mounted on the side of the pump via thread G1/4

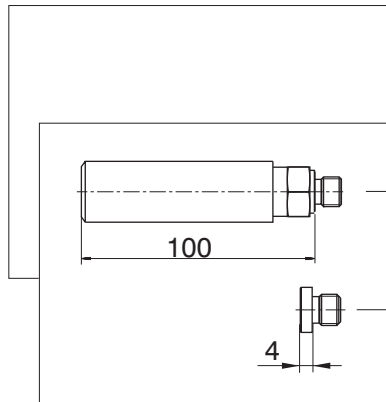

Type	Ordering number	Symbols
M Starting module	736-2801	
O Plug VSTI G1/4	336 350 000 014	

Exact position of the starting module or plug ... ref. page 18.

B

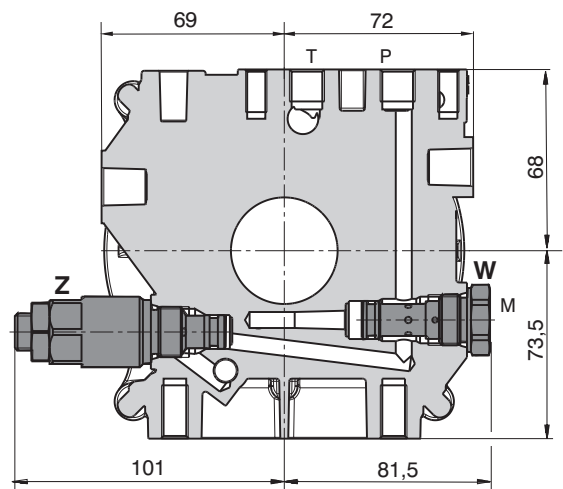
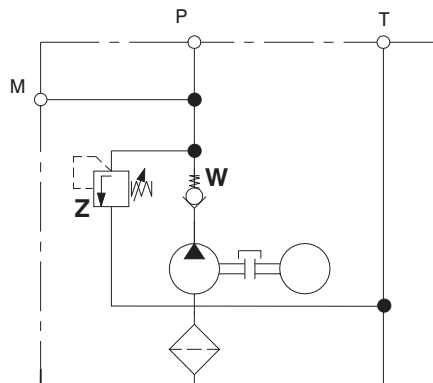

7

Basic Hydraulic Circuit Diagrams

C_{XY}

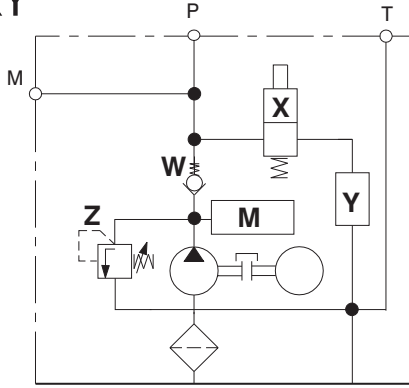

Mounted on the side of the pump via thread G1/4

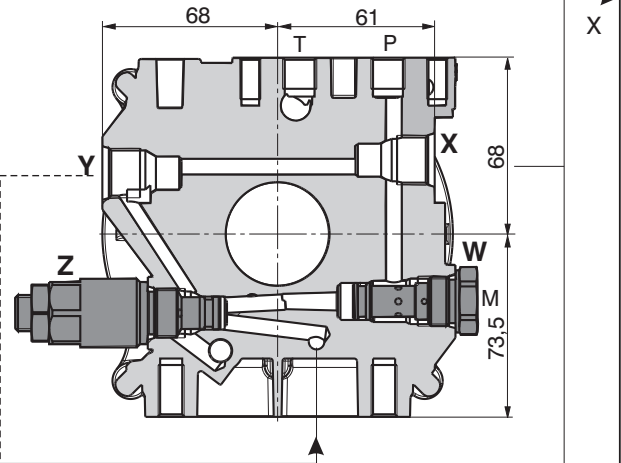

D_{XY}

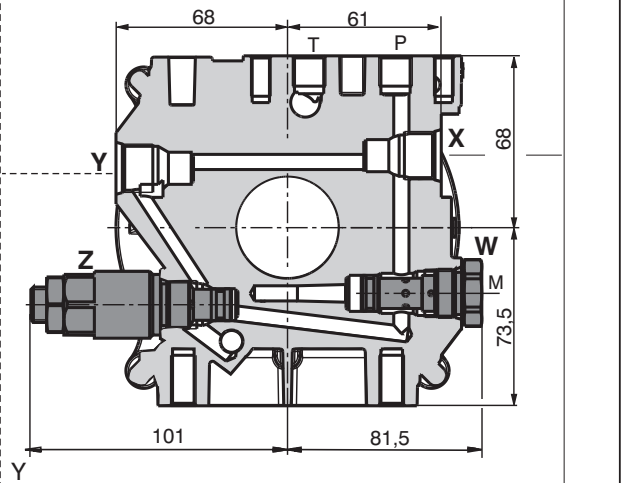
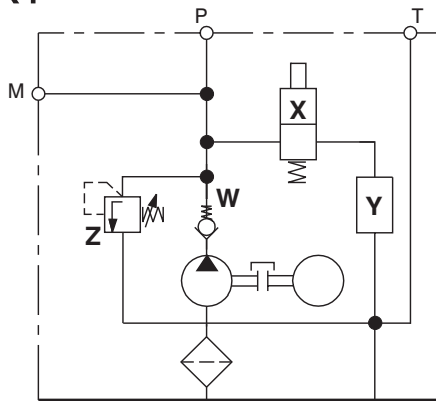

E_{XY}

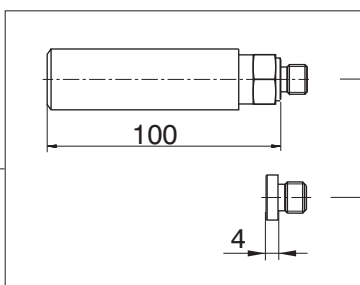
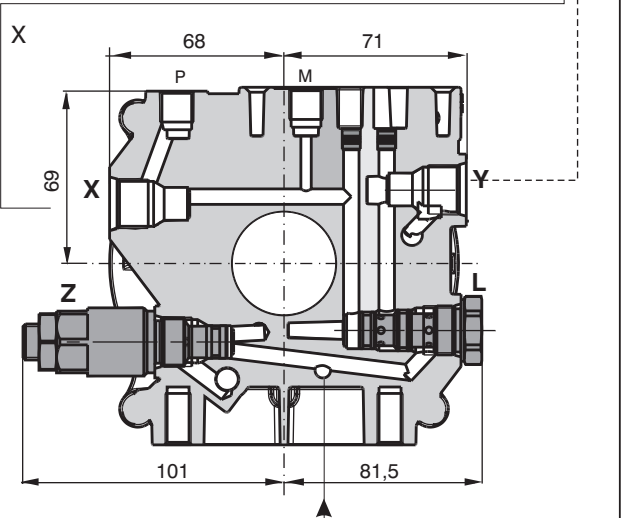
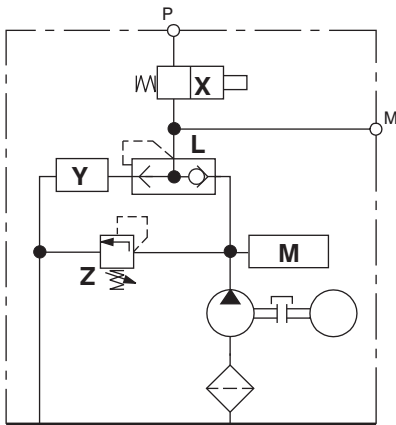

Type	Ordering number	Symbols
M Starting module	736-2801	
0 Plug VSTI G1/4	336 350 000 014	

Exact position of the starting module or plug ... ref. page 18.

X

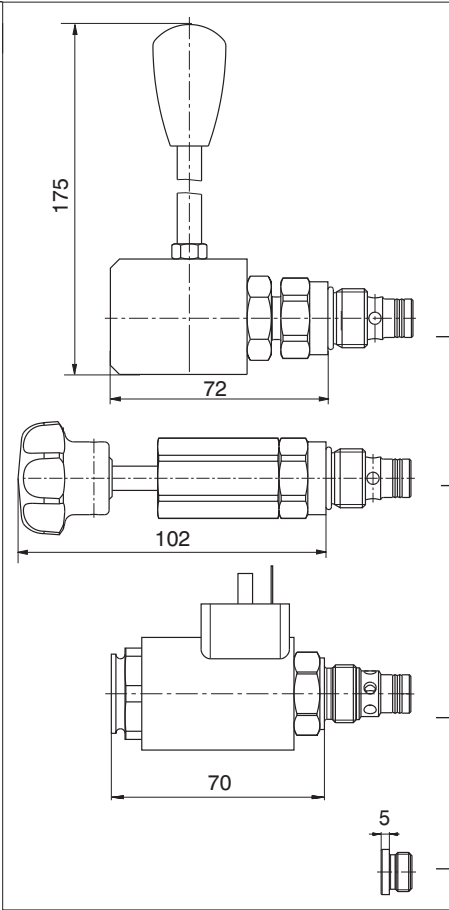

X	Type of the seat valve	Functional symbol
5	SD1M1-A2/SL3 + lever with micro switch	
4	SD1M1-A2/SL2 + lever without micro switch	
3	SD1M-A2/SL1	
2	SD3E-A2/H2O2	
1	SD3E-A2/H2L2	
0	336312341602	

Y

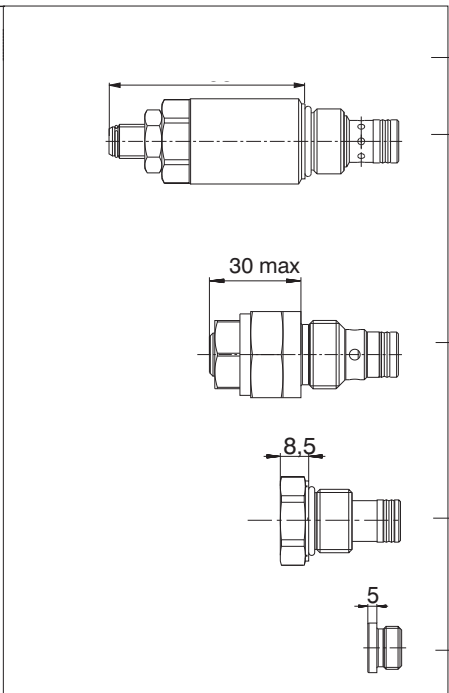

Y	Type of the throttle valve	Functional symbol
	Manually controlled pump – upon request	
2	SF22A-A2/H*	
* The size of the throttle valve corresponds regularly with the flow rate Q of the pump used. Other throttle valve size on request of the customer.		
1	VSV1-UNF	
0	531-0602 pro X = 0	
0	336 312 341 602 pro X ≠ 0	

Z	Directly Operated Pressure Relief Valves	SR1A-A2/S - Pressure range refer to data sheet HA 5063	
W	Check Valves	SC1F-A3/C	
L	Logical Valves	SSH1H-A3/C	

7

Table of Dimensions

Single-phase and three-phase motors

Code of EM	Power [kW]	Voltage [V]	Current [A]**	Speed [1/min]**	B max [mm]	C max [mm]	∅D [mm]
1	0,12	230	1,30	1300	248	139	120
2	0,18	230	1,70	1350	248	139	120
3	0,25	230	2,13	1390	261	151	141
4	0,37	230	2,82	1410	261	151	141
5	0,55	230	5,00	1370	305	157	159
6	0,75	230	6,00	1410	305	157	159
7	1,10	230	8,20	1410	314	165	174
8	1,50	230	10,00	1410	339	165	174
9	0,12	400	0,65	1320	248	101	120
10	0,18	400	0,78	1320	248	101	120
11	0,25	400	0,83	1395	261	105	140
12	0,37	400	1,14	1400	261	105	140
13	0,55	400	1,51	1390	305	127	159
14	0,75	400	1,98	1400	305	127	159
15	1,10	400	2,78	1410	314	139	174
16	1,50	400	3,61	1410	339	139	174
17	2,20	400	5,07	1425	390	148	196
18	3,00	400	6,66	1425	390	148	196
19	0,18	230	1,52	2840	248	139	120
20	0,25	230	1,90	2840	248	139	120
21	0,37	230	2,90	2780	261	151	141
22	0,55	230	4,10	2820	261	151	141
23	0,75	230	5,45	2820	305	157	159
24	1,10	230	8,00	2845	305	157	159
25	1,50	230	11,50	2855	314	165	174
26	2,20	230	14,80	2810	339	165	174
27	0,18	400	0,56	2745	248	101	120
28	0,25	400	0,73	2740	248	105	120
29	0,37	400	1,00	2790	261	105	140
30	0,55	400	1,40	2820	261	105	140
31	0,75	400	1,80	2850	305	127	159
32	1,10	400	2,54	2850	305	127	159
33	1,50	400	3,50	2855	314	139	174
34	2,20	400	4,95	2855	339	139	174
35	3,00	400	6,35	2860	390	148	196

DC electric motor

Code of EM	Power [kW]	Voltage [V]	Current [A]**	Speed [1/min]**	Load factor **		B [mm]	C [mm]	D [mm]
40	0,35	12	40	3200	S2 - 10 min	S3 - 35% ED	143	96	76
45	0,80	12	135	2700	S2 - 1 min	S3 - 4% ED	165	95	80
46	1,20	24	90	3200	S2 - 1min	S3 - 3% ED	165	95	80
51	1,50	12	220	2400	S2 - 2 min	S3 - 7% ED	179	100	117
52	2,00	24	140	2100	S2 - 3 min	S3 - 8% ED	179	100	117
63	3,00	24	200	2200	S2 - 4.5 min	S3 - 10% ED	336	121	162

Load factor

** Valid for rated power values.

Duty S1 (min) – Intended for use under continuous duty cycle conditions (load factor S1) for various press-related applications and those which involve dynamic strokes, with recommendation to consult the conditions of use with manufacturer.

Duty S2 (min) - short-time operation

The motor operates with constant load for a definite time, in order to reach the maximum permissible temperature Tmax., later on an idle period long enough to reach the equality between motor temperature and ambient temperature.

Duty S3 (%ED) - periodic operation

The operation of the motor is a continuous sequence of identical cycle, each compound from a load period and an idle period. During the load period the motor can be reach the maximum permissible temperature. S3 value shows, in percentage, the length of the load period respect to the total cycle-load period more idle period. The S3 curve quoted in the performance specifications is referred to a length's cycle of 10 minutes.

Valve Dimensions

Dimensions in millimeters

Power pack with cylindrical sheet tank, single-phase and three-phase motors

- mounting position horizontal

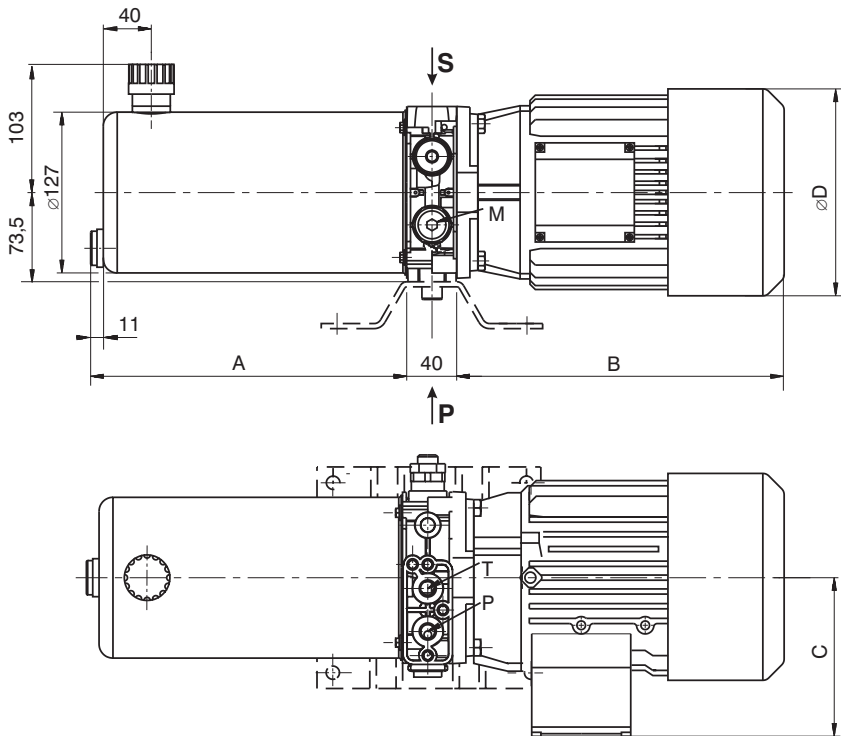

Connecting Block

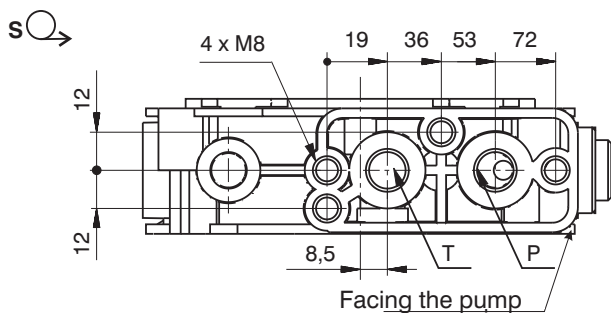

Connection holder

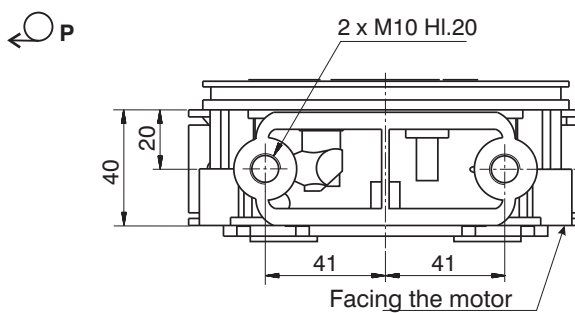

Dimensions B, C, ØD see Table of Dimensions page 10

Code of the tank	Capacity in [L]	Working volume [L]	A
10 (sheet)	1.5	0.8	151
11 (sheet)	2	1.1	251
12 (sheet)	3	1.6	331
13 (sheet)	4	2	411

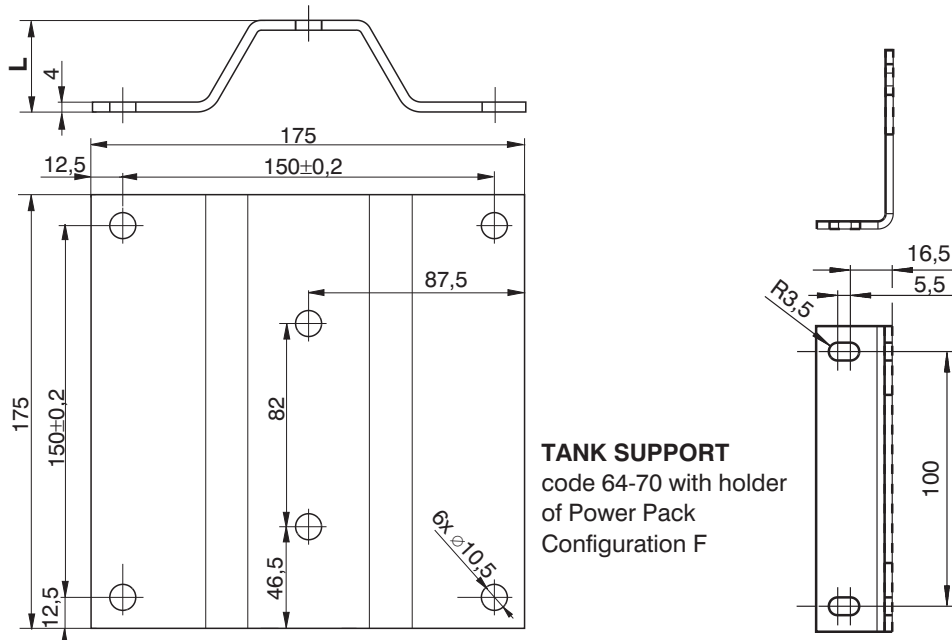

Power pack foot bracket

Typ	Dimensions L [mm]
F	37
K	62

TANK SUPPORT
code 64-70 with holder
of Power Pack
Configuration F

Valve Dimensions

Dimensions in millimeters

Power pack with cylindrical sheet tank - mounting position horizontal

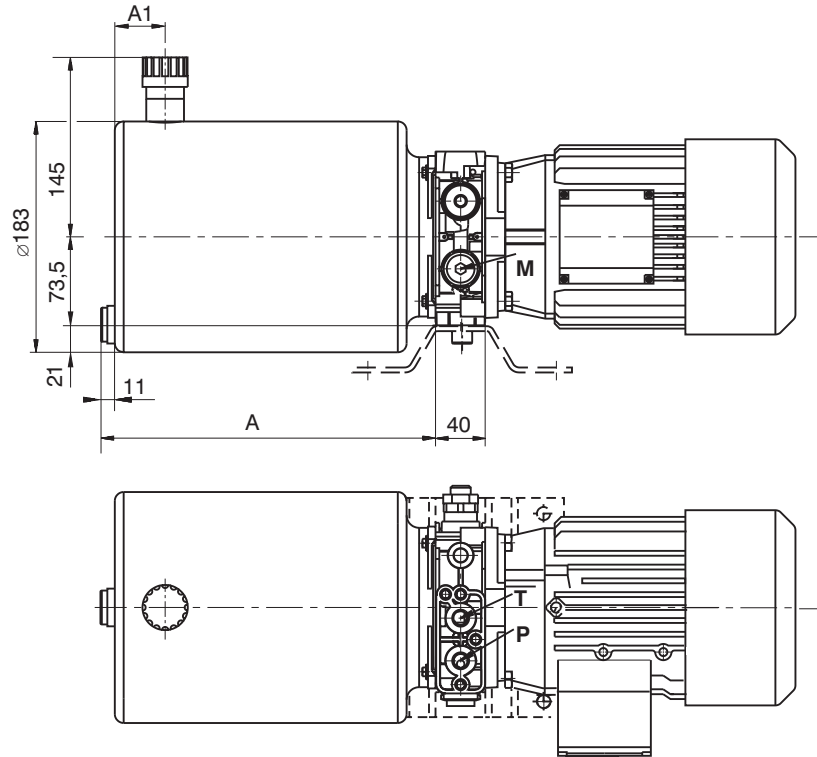

Code of the tank	Code of the tank	Working volume [L]	A	A1
20 (sheet)	6	3,7	269	40
22 (sheet)	8	4,9	349	155
24 (sheet)	10	6,1	429	195

Power pack with cylindrical sheet tank - mounting position vertical

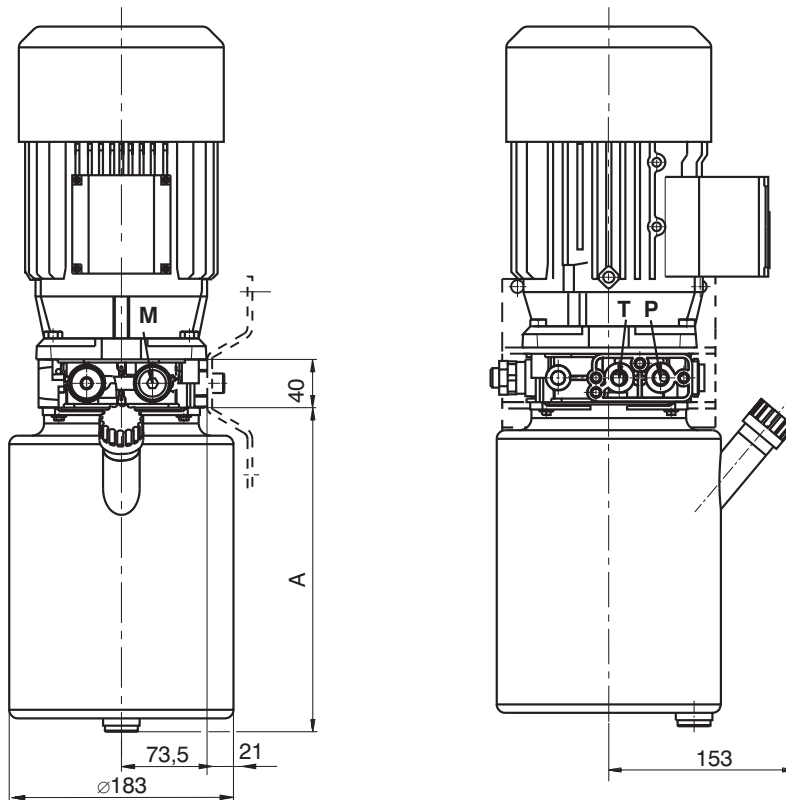

Code of the tank	Code of the tank	Working volume [L]	A
51 (sheet)	6	3,4	269
53 (sheet)	8	5,4	349
55 (sheet)	10	7,4	429

7

Valve Dimensions

Dimensions in millimeters

Power pack with cylindrical plastic tank - mounting position horizontal

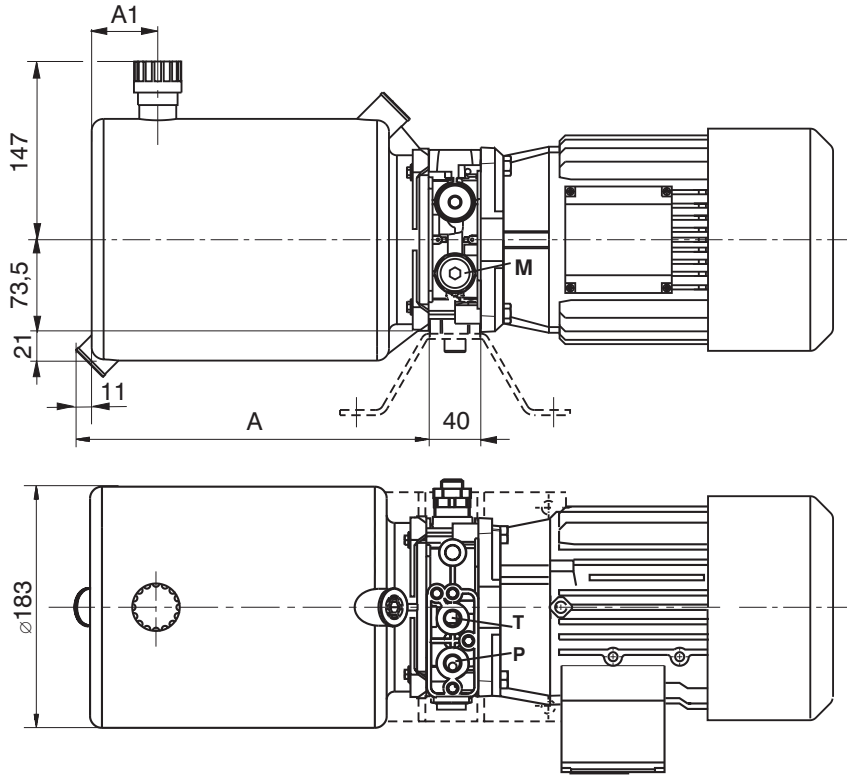

Code of the tank	Capacity in [L]	Working volume [L]	A	A1
40 (plastic)	6	3,7	280	61
42 (plastic)	8	4,9	360	121
44 (plastic)	10	6,1	440	201

Power pack with cylindrical plastic tank - mounting position vertical

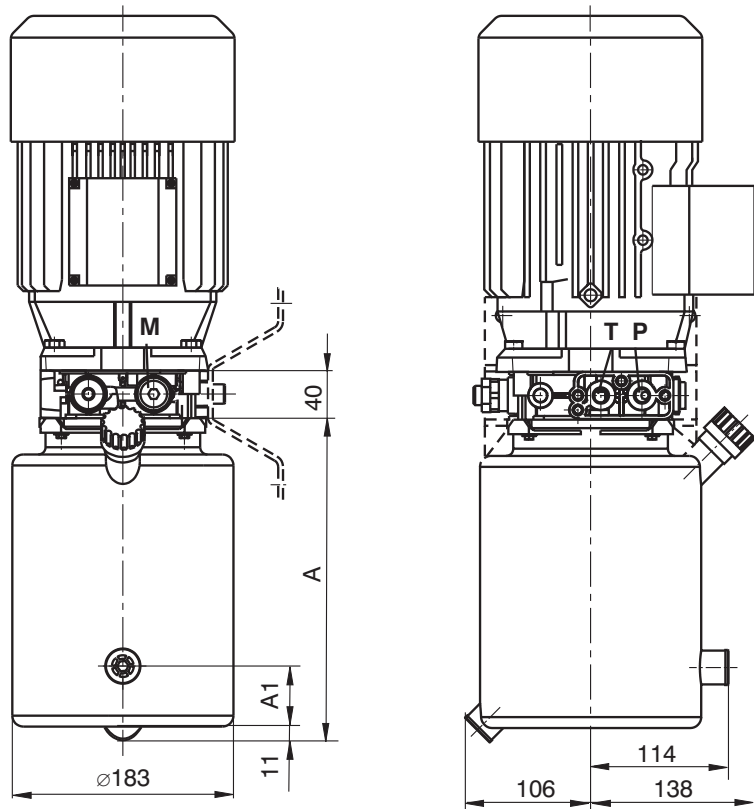

Code of the tank	Capacity in [L]	Working volume [L]	A	A1
41 (plastic)	6	3,7	280	61
43 (plastic)	8	4,9	360	121
45 (plastic)	10	6,1	440	201

7

Valve Dimensions

Dimensions in millimetres

Power pack with square plastic tank - mounting position horizontal

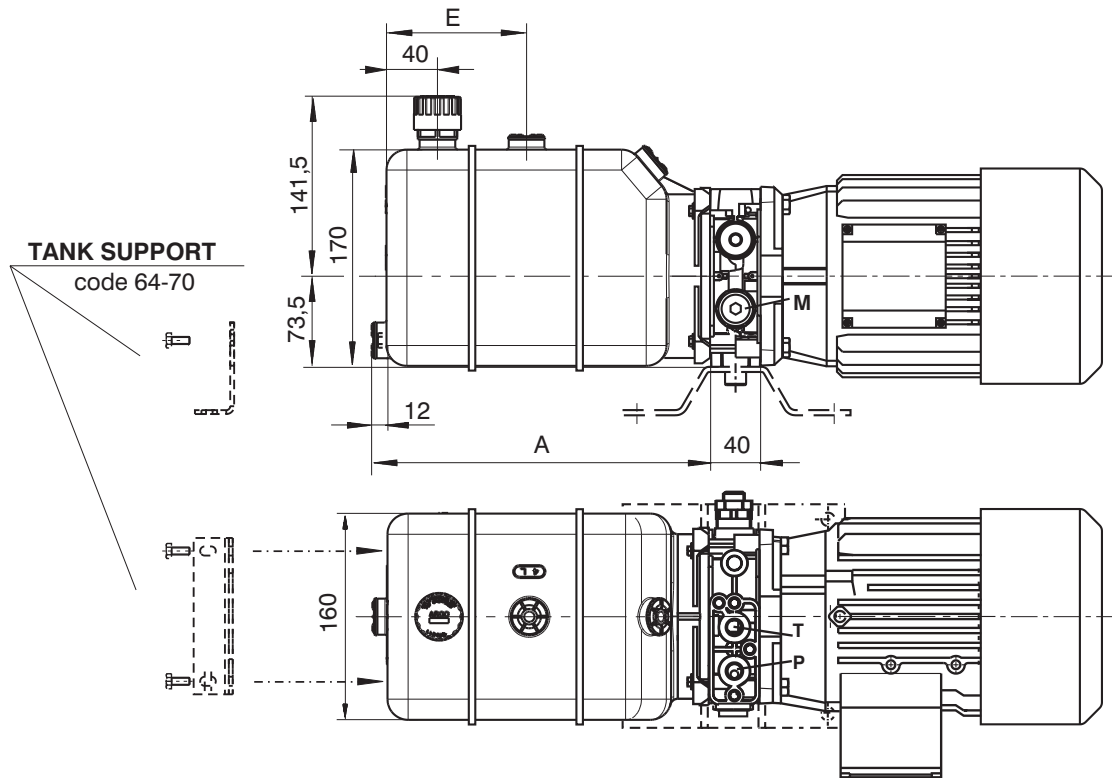

Code of the tank	Capacity in [L]	Working volume [L]	A	E
62 (Plastic)	2	1.7	178	-
64 (Plastic)	4	3.0	270	120
66 (Plastic)	6	4.5	359	165
68 (Plastic)	8	6.0	449	208
70 (Plastic)	10	7.5	543	208

Power pack with square plastic tank - mounting position vertical

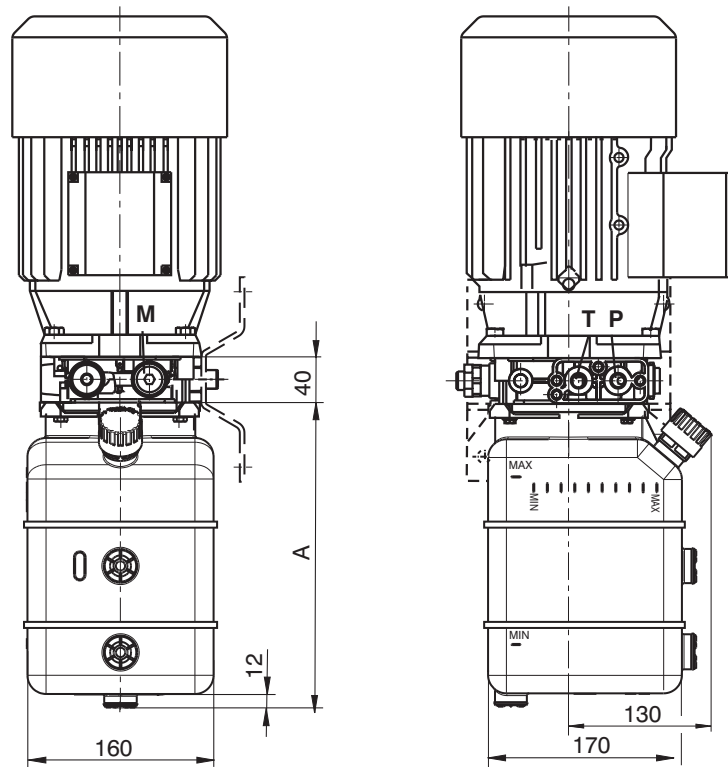

Code of the tank	Capacity in [L]	Working volume [L]	A
61 (Plastic)	2	1.3	178
63 (Plastic)	4	3.5	270
65 (Plastic)	6	5.5	359
67 (Plastic)	8	7.5	449
69 (Plastic)	10	9.5	543

7

Valve Dimensions

Dimensions in millimetres

Power pack with square sheet tank - single-phase and three-phase motors with return line filter

Configuration B, E

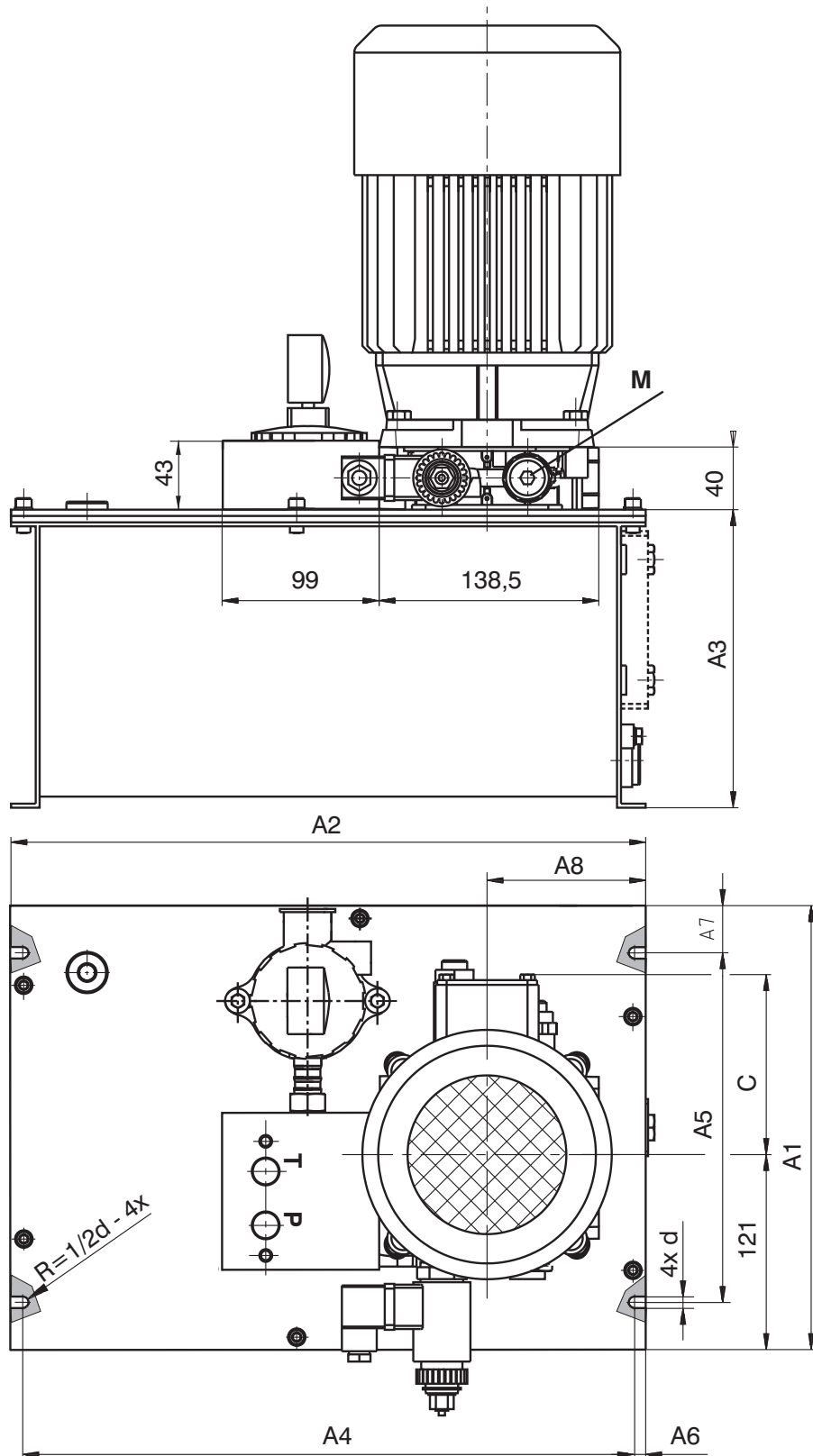

Dimensions C seehe page 10 - Table of Dimensions

Code of the tank	Capacity in [L]	Working volume [L]	A1	A2	A3	A4	A5	A6	A7	A8	d
56 (sheet)	8	4,5	280	340	165	319	220	10,5	30	100	9
57 (sheet)	10	8	280	400	188	388	220	6	30	100	9
58 (sheet)	20	16	280	400	276	388	220	6	30	100	9
59 (sheet)	30	24	320	500	287	479	260	9,5	30	132	11
60 (sheet)	40	34	320	500	366	479	260	9,5	30	132	11

7

Valve Dimensions

Dimensions in millimeters

Power pack with cylindrical sheet tank - with DC electric motor out return line filter

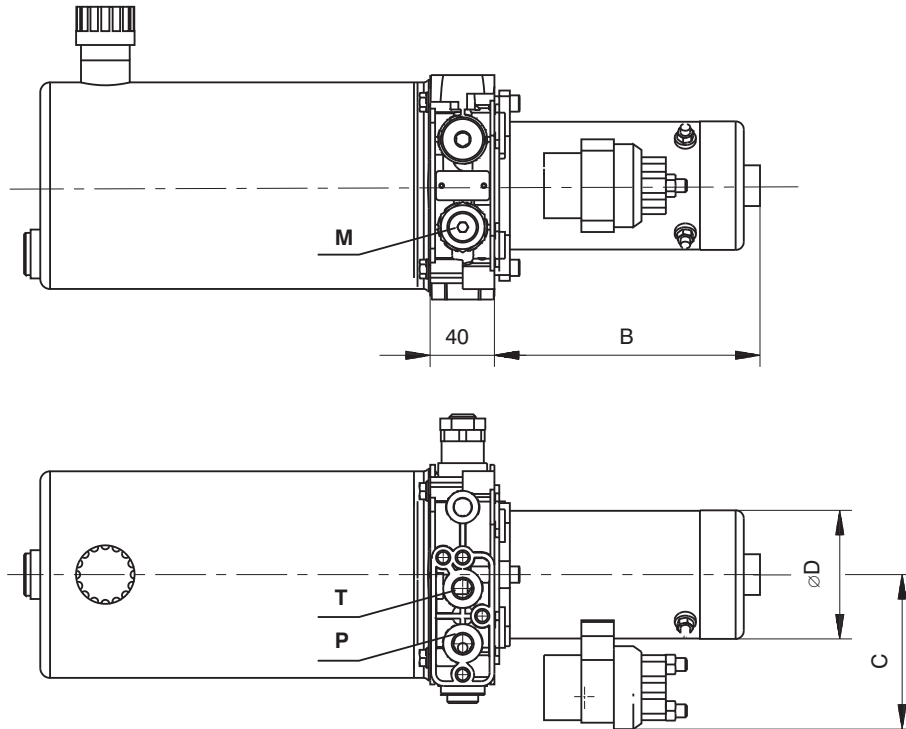

Power pack with square sheet tank - with DC electric motor out return line filter

Optional stacking assembly, versions B, E ref. page 12.

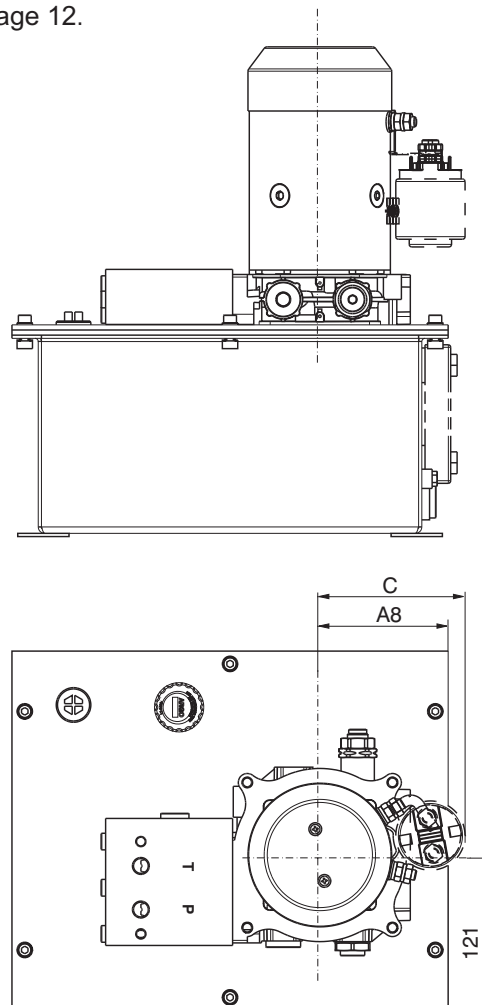

Dimensions B, C, ØD see page 10 - Table of Dimensions
 Dimensions A8 see page 15

SMA 05 - Illustration Figure

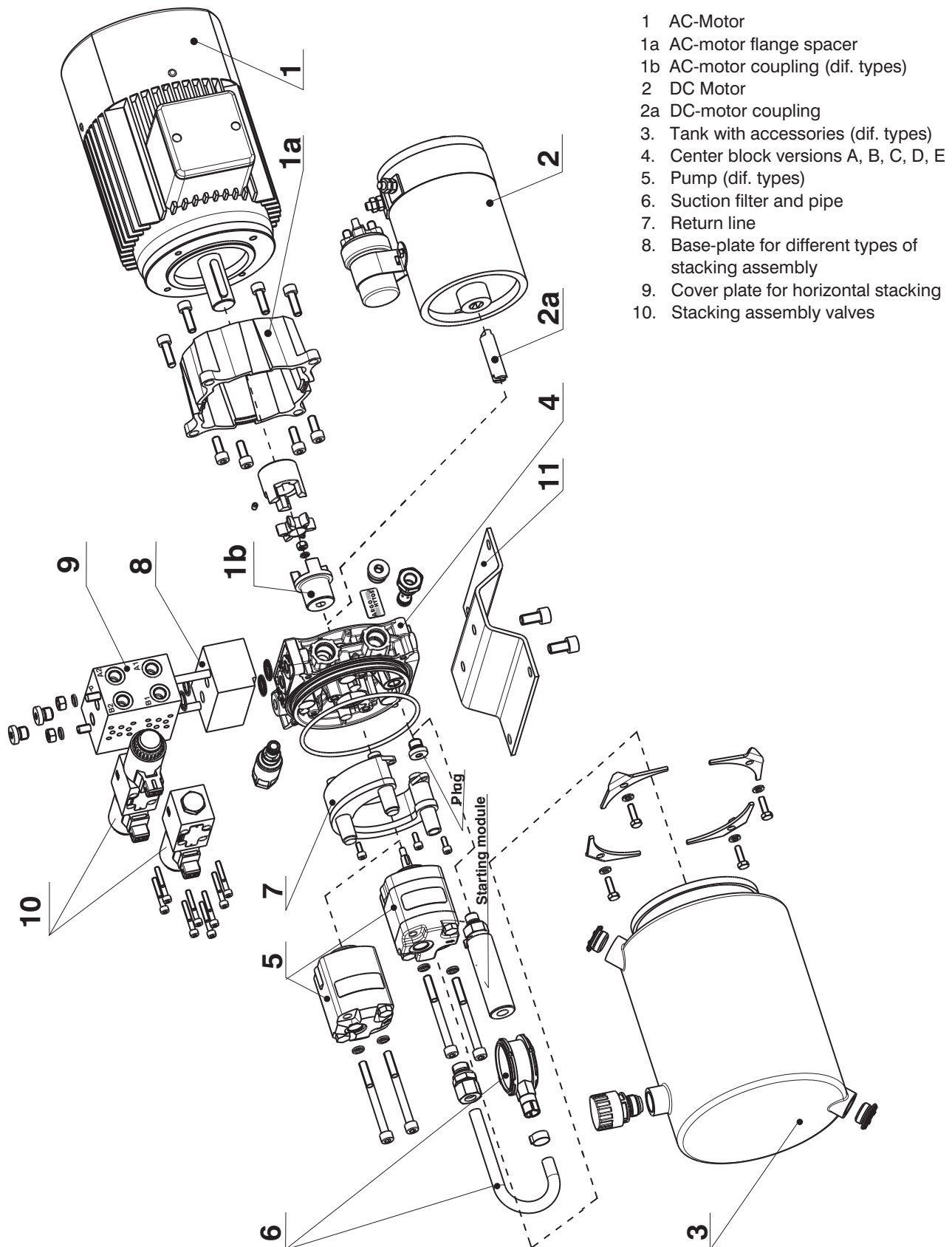
**Caution!**

- The packing foil is recyclable.
- The technical information regarding the product presented in this catalogue is for descriptive purposes only. It should not be construed in any case as a guaranteed representation of the product properties in the sense of the law.

ARGO-HYTOS s.r.o. CZ - 543 15 Vrchlaví
 Tel.: +420-499-403111, Fax: +420-499-403421
 E-mail: sales.cz@argo-hytos.com
 www.argo-hytos.com

Accessories, Connecting Plates

8

Accessories, Connecting Plates

Type Code		Page	Data Sheet
C14,C19,C22,C31	Coils for Solenoid Operated Valves	8.01	HA 8007
TS4, MTS	Pressure Switch Sandwich Plate	8.02	HA 9204
TSE	Electrical Pressure Switch	8.03	HA 9203
RC	Manually-Operated Single-Acting Piston Pump	8.04	HA 2020
DP6	Basic Manifold with Pressure Relieve Valves	8.05	HA 0012
DR1-04	In-line-Manifolds	8.06	HA 0017
DR2-06	In-line-Manifolds	8.07	HA 0026
PD10	In-line Manifolds	8.08	HA 0008
SB-04 (06)	Sandwich Plates for Valves	8.09	HA 0028
SB	Bodies for Screw in Cartridge Valves	8.10	HA 0018
Dn 04, 06, 10	Subplates for Valves	8.11	HA 0002
Dn 04, 06, 10	Blanking Plates	8.12	HA 0003
Dn 04	Studs and Nuts for Vertical Stacking Assemblies	8.13	HA 0020
Dn 06	Studs and Nuts for Vertical Stacking Assemblies	8.14	HA 0030
Dn 10	Studs and Nuts for Vertical Stacking Assemblies	8.15	HA 0040
"3/4-16UNF, 7/8-14UNF, M20x1,5, M22x1,5 ,M27x2, G1/8"	Standard Cavity Plugs	8.16	HA 0050
SMT	Screw in Cartridge Manufacturing Tools	8.17	HA 0019

- Various designs regarding sizes and types
- Large selection of AC / DC voltages

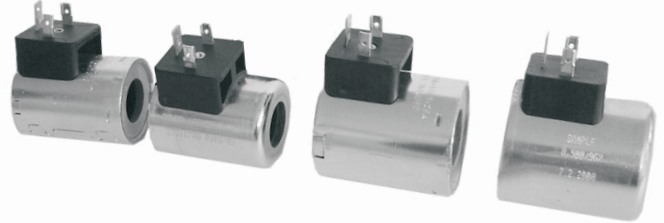

Ordering Code

C			-				-				/	M
Electromagnet coil												
Coil design (Size - according to the inner diameter)												
Ø 13,4 mm	14											
Ø 19,0 mm	19											
Ø 19,0 mm	20											
Ø 22,0 mm	22											
Ø 31,0 mm	31											
Coil housing design version												
Scrolled housing	A											
Drawn housing	B											
Long drawn housing	C											
Pressed part	D											
Rated voltage of solenoid (at the coil terminals)												
12 V DC	01200											
14 V DC	01400											
24 V DC	02400											
27 V DC	02700											
48 V DC	04800											
106 V DC	10600											
205 V DC	20500											
115 V 50 Hz	11050											
Type of solenoid coil see the page 18												
											E..	
Conductor design												
Non-braided												N
Braided												B
* For loose conductors only												
Special design												
Insulation design												
No designation											H	
Standard												
Version CSA												
Surface treatment												
A											A	
B											B	
											ZnCr ₃	
											Zn/Ni	
Detent type*												
N											N	
F											F	
											Without detent	
											With detent	
*C31 coils only												
Resistance												
...											...	
											Coil resistance (Ω)	
See the table of preferred coils												
Length of conductors												
300											300	
...											...	
											Standard (300 mm)	
											according to customer's requirements	
* For loose conductors only												

Coils C14

Valve type	Voltage		Current		Type of solenoid coil			
	[V]	[A]	E1	E2	E3A	E4A		
RPEK1	01200	1,83	16210300	24101600	28822500	28822600		
			C14B-01200E1-6,55NA	C14B-01200E2-6,55NA	C14B-01200E3A-6,55NA	C14B-01200E4A-6,55NA		
	02400	0,92	16210400 C14B-02400E1-26,2NA	24101800 C14B-02400E2-26,2NA	28886400 C14B-02400E3A-6,55NA	28822400 C14B-02400E4A-6,55NA		
	20500**	0,08	16210500 C14B-20500E1-2476NA					

Notes: Only specified combinations are available in the table of preferred types. Other designs available at request.

* Coil versions 106 are suitable for the rectified voltage of 120V / 60Hz.

** Coil version 205 are suitable for the rectified voltage of 230V /50Hz.

Coils C19		Type of solenoid coil									
Valve type	Voltage	Current	E1	E2	E3	E4	E3A	E4A			
	[V]	[A]									
RPE3-04 ROE3-04 ROE3-06	01200	2,41	27316600 C19B-01200E1-4,98NA	27631400 C19B-01200E2-4,98NA	27330200 C19B-01200E3-4,98NA	27631600 C19B-01200E4-4,98NA	27449800 C19B-01200E3A-4,98NA	27631900 C19B-01200E4A-4,98NA			
	01400	1,66	27634100 C19B-01400E1-8,23NA	27634200 C19B-01400E2-8,23NA	27634300 C19B-01400E3-8,23NA	27634400 C19B-01400E4-8,23NA	27634500 C19B-01400E3A-8,23NA	27634600 C19B-01400E4A-8,23NA			
	02400	1,15	27316700 C19B-02400E1-20,8NA	27632400 C19B-02400E2-20,8NA	27330300 C19B-02400E3-20,8NA	27633200 C19B-02400E4-20,8NA	27449700 C19B-02400E3A-20,8NA	27633400 C19B-02400E4A-20,8NA			
	02700	0,89	27636100 C19B-02700E1-30,4NA	27639400 C19B-02700E2-30,4NA	27641600 C19B-02700E3-30,4NA	27641700 C19B-02700E4-30,4NA	27641800 C19B-02700E3A-30,4NA	27642100 C19B-02700E4A-30,4NA			
	04800	0,56	27823500 C19B-04800E1-86,9NA	----	----	----	----	----			
	10600*	0,22	27642600 C19B-10600E1-494NA	----	----	----	----	----			
	20500**	0,12	27382401 C19B-20500E1-1653NA	----	----	----	----	----			
	12060	0,22	----	----	----	----	----	----			
	23050	0,12	----	----	----	----	----	----			
	01200 CSA	2,41	24140700 C19A-01200E1-4,98NAH	----	----	----	----	----			
	02400 CSA	1,15	24140800 C19A-02400E1-21NAH	----	----	----	----	----			
	115500 CSA 23000 CSA	0,24 0,14	----	----	----	----	----	----			
SD2E-A2/H SD2E-A3/H SD2E-A4/H SD3E-A2/H	01200	1,7	27666300 C19B-01200E1-7,1NA	27666700 C19B-01200E2-7,1NA	27667000 C19B-01200E3-7,1NA	27667100 C19B-01200E4-7,1NA	----	----			
	01400	1,46	27823600 C19B-01400E1-9,6NA	----	----	----	----				
	02400	0,83	27667700 C19B-02400E1-28,8NA	27667800 C19B-02400E2-28,8NA	27667900 C19B-02400E3-28,8NA	27668000 C19B-02400E4-28,8NA	----	----			
	10600*	0,2	27668400 C19B-10600E1-527NA	----	----	----	----				
	20500**	0,1	27668700 C19B-20500E1-2065NA	----	----	----	----				
	12060	0,21	----	----	----	----	----				
	23050	0,11	----	----	----	----	----				



Coils C19

Valve type	Type of solenoid coil						
	Voltage [V]	Current [A]	E5	E8	E9	E12	E13
RPE3-04 ROE3-04 ROE3-06	01200	2,41	---	27632200 C19B-01200E8N300-4,98NA	27632100 C19B-01200E9N300-4,98NA	27351400 C19B-01200E12-4,98NA	27632000 C19B-01200E13-4,98NA
	01400	1,66	---	27634800 C19B-01400E8N300-8,23NA	27634900 C19B-01400E9N300-8,23NA	27635000 C19B-01400E12-8,23NA	27635100 C19B-01400E13-8,23NA
	02400	1,15	---	27633700 C19B-02400E8N300-20,8NA	27633600 C19B-02400E9N300-20,8NA	27330500 C19B-02400E12-20,8NA	27633500 C19B-02400E13-20,8NA
	04800	0,56	---	---	---	---	---
	10600*	0,22	---	---	---	---	---
	20500**	0,12	---	---	---	---	---
	12060	0,22	27642700 C19B-12060E5-494NA	---	---	---	---
	23050	0,12	27449900 C19B-23050E5-1653NA	---	---	---	---
	01200 CSA	2,41	---	---	---	---	---
	02400 CSA	1,15	---	---	---	---	---
SD2E-A2/H SD2E-A3/H SD2E-A4/H SD3E-A2/H	11550 CSA	0,24	24140900 C19A-11550E5-433NAH	---	---	---	---
	23050 CSA	0,12	24141000 C19A-23050E5-1653NAH	---	---	---	---
	01200	1,7	---	27667300 C19B-01200E8N300-7,1NA	27667400 C19B-01200E9N300-7,1NA	27351200 C19B-01200E12-7,1NA	27667500 C19B-01200E13-7,1NA
	01400	0,89	---	---	27866600 C19B-01400E9N300-9,6NA	---	---
	02400	0,83	---	27668200 C19B-02400E8N300-28,8NA	27668300 C19B-02400E9N300-28,8NA	27442600 C19B-02400E12-28,8NA	27667600 C19B-02400E13-28,8NA
	02700	0,74	---	---	27866400 C19B-012700E9N300-36,5NA	---	---
	10600*	0,2	---	---	---	---	---
	20500**	0,1	---	---	---	---	---
	12060	0,21	27668500 C19B-12060E5-527NA	---	---	---	---
	23050	0,11	27668600 C19B-23050E5-2065NA	---	---	---	---

Coils C19										
Valve type	Voltage [V]	Current [A]	Type of solenoid coil							
			E1	E2	E3	E4	E5	E8	E9	
SD2E-B2/S SD2E-B3/S SD2E-B4/S SD3E-B2/S SD1E-A2	01200	2	27669700 C19B-01200E1-6NA	27669900 C19B-01200E2-6NA	27670000 C19B-01200E3-6NA	27670100 C19B-01200E4-6NA	---	27670300 C19B-01200E8N300-6NA	27670400 C19B-01200E9N300-6NA	
	01400	1,66	27634100 C19B-01400E1-8,23NA	27634200 C19B-01400E2-8,23NA	27634300 C19B-01400E3-8,23NA	27634400 C19B-01400E4-8,23NA	---	27634800 C19B-01400E8-8,23NA	27634900 C19B-01400E9-8,23NA	
	02400	0,93	27670600 C19B-02400E1-25,75NA	27670700 C19B-02400E2-25,75NA	27670800 C19B-02400E3-25,75NA	27670900 C19B-02400E4-25,75NA	---	27671000 C19B-02400E8N300-25,75NA	27671100 C19B-02400E9N300-25,75NA	
	02700	0,89	27639100 C19B-02700E1-30,4NA	27639400 C19B-02700E2-30,4NA	27641600 C19B-02700E3-30,4NA	27641700 C19B-02700E4-30,4NA	---	27642200 C19B-02700E8N300-30,4NA	27642300 C19B-02700E9N300-30,4NA	
	10600*	0,22	27642800 C19B-10600E1-494NA	---	---	---	---	---	---	
	20500**	0,12	27382401 C19B-20500E1-1653NA	---	---	---	---	---	---	
	12060	0,24	---	---	---	---	27642700 C19B-12060E5-494NA	---	---	
	23050	0,13	---	---	---	---	27449900 C19B-23050E5-1653NA	---	---	
	PRM2-04 with electronic	01200	max.1,7	16186100 C19A-01200E1-4,98NA/M	---	---	---	---	---	---
				27821900 C19B-01200E1-4,68NA/M	---	---	---	---	---	---
16186200 C19A-02400E1-21NA/M				---	---	---	---	---	---	
27824200 C19B-02400E1-20,8NA/M				---	---	---	---	---	---	
PRM7-04 with electronic	02400	max.0,8	---	---	---	---	---	---		
			---	---	---	---	---	---		
PVRM1-063/S	01200	max.1	---	---	---	---	---	---		
			23881200 C19B-01200E4-7,1NA/M	---	---	---	---	---	---	
Coils C20										
Valve type	Voltage [V]	Current [A]	Type of solenoid coil							
			E2	E4	E13					
SR1P2-A2 SR4P2-B2 SP4P2-B3	01200	1	28145600 C19B-01200E2-6,5NA	28145800 C19B-01200E4-6,5NA	---	---	---	29867600 C19B-01200E13-6,5NA		
	02400	0,75	28145100 C19B-02400E2-20,1NA	28145300 C19B-02400E4-20,1NA	---	---	---	29868600 C19B-02400E13-20,8NA		
RPEW4-06	12060	0,27	C20D-12060EW5-27,6N/M							
			Type of solenoid coil							

Notes: Only specified combinations are available in the table of preferred types. Other designs available at request.
 * Coil versions 106 are suitable for the rectified voltage of 120V / 60Hz.
 ** Coil version 205 are suitable for the rectified voltage of 230V / 50Hz.



Coils C22

Valve type	Type of solenoid coil						
	Voltage [V]	Current [A]	E1	E2	E3A	E4A	E5
RPE3-06	01200	2,72	16211400 C22B-01200E1-4,41NA	24156100 C22B-01200E2-4,41NA	24159600 C22B-01200E3A-4,41NA	24159700 C22B-01200E4A-4,41NA	---
	01400	2,14	24158200 C22B-01400E1-6,55NA	24930900 C22B-01400E2-6,55NA	27662100 C22B-01400E3A-6,55NA	27662200 C22B-01400E4A-6,55NA	---
	02400	1,29	16211600 C22B-02400E1-18,6NA	24157400 C22B-02400E2-18,6NA	24159800 C22B-02400E3A-18,6NA	24159900 C22B-02400E4A-18,6NA	---
	02700	1,07	16211700 C22B-02700E1-25,3NA	24157600 C22B-02700E2-25,3NA	19744600 C22B-02700E3A-25,3NA	19744500 C22B-02700E4A-25,3NA	---
	10600*	0,26	24157800 C22B-10600E1-400NA	---	---	---	---
	20500**	0,15	16211500 C22B-20500E1-1400NA	---	---	---	---
	11550	0,3	---	---	---	---	27510100 C22B-11550E5-344NA
	12060	0,26	---	---	---	---	---
	23050	0,15	---	---	---	---	18849000 C22B-23050E5-1400NA
	01200 CSA	2,72	24154300 C22A-01200E1-4,41NAH	---	---	---	---
SD2E-B2/H SD2E-B3/H SD2E-B4/H SD3E-B2/H	02400 CSA	1,29	24154400 C22A-02400E1-18,6NAH	---	---	---	---
	23050 CSA	0,15	---	---	---	---	24154600 C22A-23050E5-1393NAH
	01200	1,83	27222400 C22B-01200E1-6,55NA	27222500 C22B-01200E2-6,55NA	27222600 C22B-01200E3A-6,55NA	27222700 C22B-01200E4A-6,55NA	---
	02400	0,95	27222800 C22B-02400E1-25,3NA	27222900 C22B-02400E2-25,3NA	27223000 C22B-02400E3A-25,3NA	27223100 C22B-02400E4A-25,3NA	---
	10600*	0,19	27223200 C22B-10600E1-545NA	---	---	---	---
	20500**	0,09	24160100 C22B-20500E1-2353NA	---	---	---	---
	12060	0,19	---	---	---	---	20004100 C22B-12060E5-545NA
	23050	0,09	---	---	---	---	20004200 C22B-23050E5-2353NA

Notes: Only specified combinations are available in the table of preferred types. Other designs available at request.

* Coil versions 106 are suitable for the rectified voltage of 120V / 60Hz.

** Coil version 205 are suitable for the rectified voltage of 230V / 50Hz.

Coils C22

Valve type	Voltage [V]	Current [A]	Type of solenoid coil					
			E8	E9	E12	E13		
RPE3-06	01200	2,72	19961300 C22B-01200E8N300-4,41NA	19961400 C22B-01200E9N300-4,41NA	24930801 C22B-01200E12-4,41NA	19695100 C22B-01200E13-4,41NA		
	01400	2,14	27662500 C22B-01400E8N300-6,55NA	27662900 C22B-01400E9N300-6,55NA	27663000 C22B-01400E12-6,55NA	27663100 C22B-01400E13-6,55NA		
	02400	1,29	19961000 C22B-02400E8N300-18,6NA	19961700 C22B-02400E9N300-18,6NA	19695900 C22B-02400E12-18,6NA	19696000 C22B-02400E13-18,6NA		
	02700	1,07	27662700 C22B-02700E8N300-25,3NA	27662800 C22B-02700E9N300-25,3NA	27663200 C22B-02700E12-25,3NA	27663300 C22B-02700E13-25,3NA		
	SD2E-B2/H	01200	1,83	19963200 C22B-01200E8N300-6,55NA	19963400 C22B-01200E9N300-6,55NA	18815601 C22B-01200E12-6,55NA	19909000 C22B-01200E13-6,55NA	
	SD2E-B3/H	02400	0,95	19963500 C22B-02400E8N300-25,3NA	18069900 C22B-02400E9N300-25,3NA	19909101 C22B-02400E12-25,3NA	19909200 C22B-02400E13-25,3NA	

Notes: Only specified combinations are available in the table of preferred types. Other designs available at request.

* Coil versions 106 are suitable for the rectified voltage of 120V / 60Hz.

** Coil version 205 are suitable for the rectified voltage of 230V / 50Hz.

Coils C22

Valve type	Voltage [V]	Current [A]	Type of solenoid coil			
			E1	E3A	EW1	EW2
RPEA3-06	02400	0,33	---	---	24014000 C22C-02400EW1-72NAH/M	---
	01200	2,72	---	---	16205100 C22C-01200EW1-4,54NAH/M	16205400 C22C-01200EW2-4,54NAH/M
RPEW4-06	02400	1,26	---	---	16205000 C22C-02400EW1-18,2NAH/M	16205500 C22C-02400EW2-18,2NAH/M
	10600	0,27	---	---	24154700	---
	01200 CSA	2,64	---	---	24154900 C22C-02400EW1-18,2NAH/M	---
PRM2-06	01200	max 2,5	16186400 C22A-01200E1-2,33NA	---	---	---
	01200	max 1,6	16187500*** C22A-01200E1-5,15NA	---	---	---
	02400	max 1	16186800 C22A-02400E1-13,4NA	---	---	---
PRM7-06	01200	max 2,5	16186400 C22A-01200E1-2,33NA	---	---	---
	02400	max 1	16186800 C22A-02400E1-13,4NA	---	---	---
PVRM3-10	01200	max 1,5	---	24157900 C22B-01200E3A-5NA	---	---

Notes: Only specified combinations are available in the table of preferred types. Other designs available at request.

* Coil versions 106 are suitable for the rectified voltage of 120V / 60Hz.

** Coil version 205 are suitable for the rectified voltage of 230V / 50Hz.

*** Input signal level for 12V-electronics.

Coils C31										
Valve type	Voltage [V]	Current [A]	Type of solenoid coil							
			E1	E2	E3	E4	E5	E8	E9	EW1
RPE4-10	01200	3,17	16195700 C31A-01200E1-3,78FA	27660800 C31A-01200E2-3,78FA	16197000 C31A-01200E3-3,78FA	16196900 C31A-01200E4-3,78FA	---	16198800 C31A-01200E8N300-3,78FA	23910200 C31A-01200E9N300-3,78FA	---
	01400	2,98	16195900 C31A-01400E1-4,73FA	27660900 C31A-01400E2-4,73FA	27661100 C31A-01400E3-4,73FA	27661200 C31A-01400E4-4,73FA	---	27661500 C31A-01400E8N300-4,73FA	27661600 C31A-01400E9N300-4,73FA	---
	02400	1,73	16196100 C31A-02400E1-13,9FA	23896000 C31A-02400E2-13,9FA	16197200 C31A-02400E3-13,9FA	16197100 C31A-02400E4-13,9FA	---	23904500 C31A-02400E8N300-13,9FA	23910300 C31A-02400E9N300-13,9FA	---
	02700	1,52	16196300 C31A-02700E1-17,8FA	27661000 C31A-02700E2-17,8FA	27661300 C31A-02700E3-17,8FA	27661400 C31A-02700E4-17,8FA	---	27661700 C31A-02700E8N300-17,8FA	27662000 C31A-02700E9N300-17,8FA	---
	10600*	0,38	23898000 C31A-10600E1-276FA	---	---	---	---	---	---	---
	20500**	0,2	16196700 C31A-20500E1-1027FA	---	---	---	---	---	---	---
	12060	0,38	---	---	---	---	17366300 C31A-12060E5-276FA	---	---	---
	23050	0,2	---	---	---	---	16195100 C31A-23050E5-1027FA	---	---	---
	01200	3,17	---	---	---	---	---	---	---	24172000 C31A-01200EW1-3,78FA/M
	02400	1,73	---	---	---	---	---	---	---	24172200 C31A-02400EW1-13,9FA/M
16000	0,38	---	---	---	---	---	---	---	24172400 C31A-10600EW1-276FA/M	
01200	max.1,9	16195600 C31A-01200E1-4,73FA	---	---	---	---	---	---	---	
02400	max.1,1	16196200 C31A-02400E1-13,9FA/M	---	---	---	---	---	---	---	

Notes: Only specified combinations are available in the table of preferred types. Other designs available at request.
 * Coil versions 106 are suitable for the rectified voltage of 120V / 60Hz.
 ** Coil version 205 are suitable for the rectified voltage of 230V / 50Hz.



Rectifier Connection in the Coil with "E5" Connector

In-built bridge rectifier for the maximum output voltage $253 V_{eff}$
 Voltage frequency 50 – 60 Hz. Varistor for $275 V_{eff}$

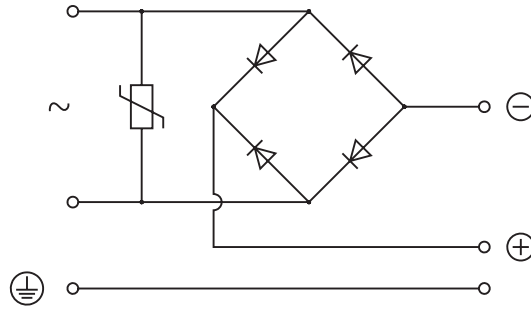

Dimensions of Coils C14

Dimensions in millimeters (inches)

Design version - B

Connector design

E1 (Connector EN 175301-803-A)

Protection degree IP65

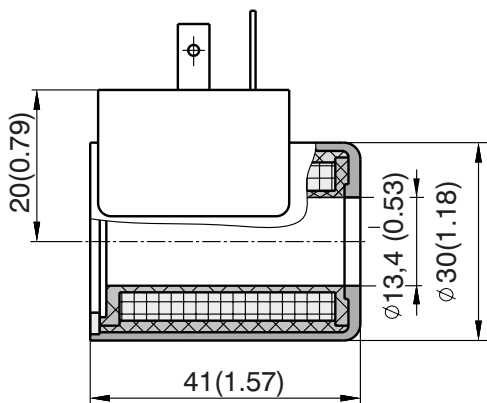

Connector design

E3A (Connector AMP-Junior-Timer - (2-pins; male)

E4A (E3A with quenching diode)

Protection degree IP67

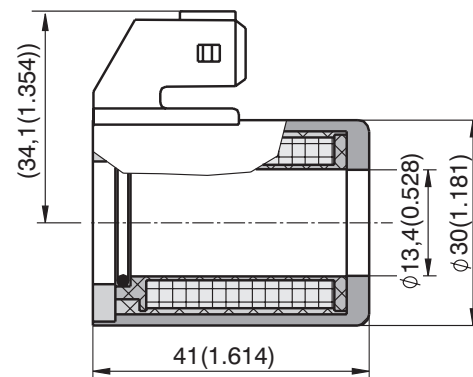

Dimensions of Coils C19

Dimensions in millimeters (inches)

Design version - A

Connector design

E1 (Connector EN 175301-803-A)

E2 (E1 with quenching diode)

Protection degree IP65

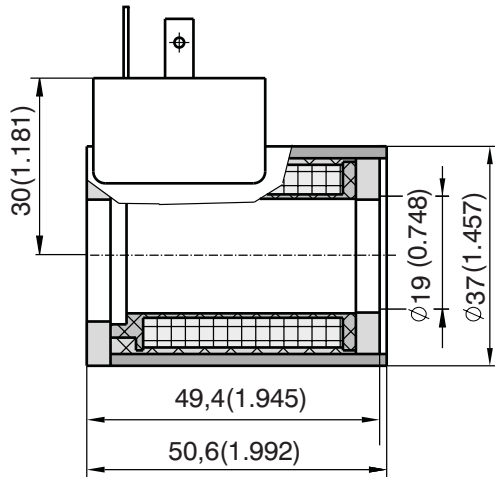

Design version - B

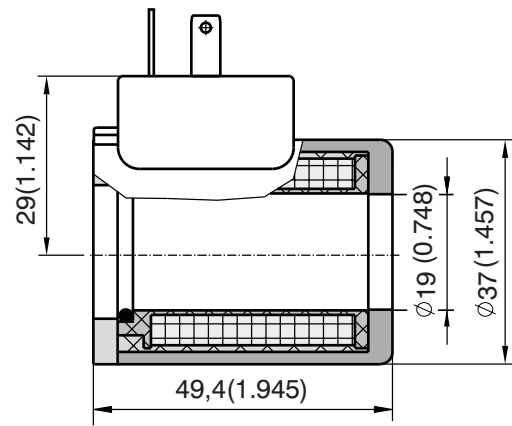

Design version - B

Connector design

E3 (Connector AMP-Junior-Timer - (2-pins; male)

E4 (E3 with quenching diode)

Protection degree IP67

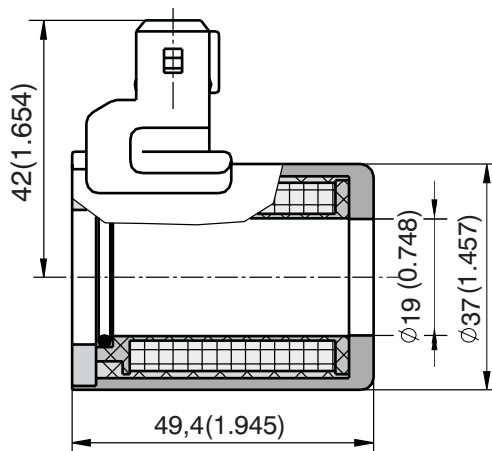

Design version - B

Connector design

E3A (Connector AMP-Junior-Timer - (2-pins; male)

E4A (E3A with quenching diode)

Protection degree IP67

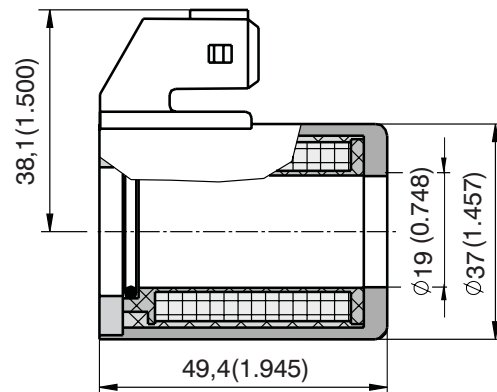

Dimensions of Coils C19

Dimensions in millimeters (inches)

Design version - A

Connector design

E5 (Connector EN 175301-803-A with integrated rectifier)

Protection degree IP67

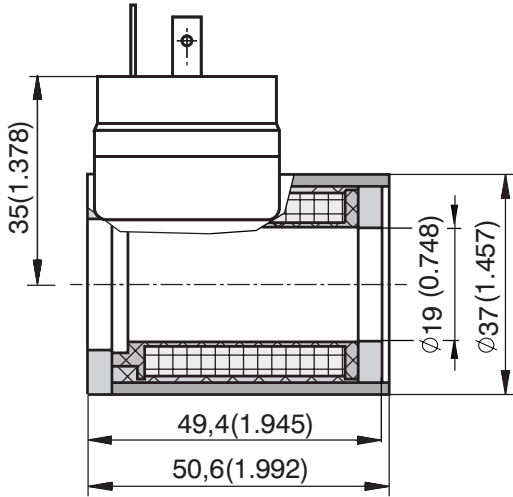

Design version - B

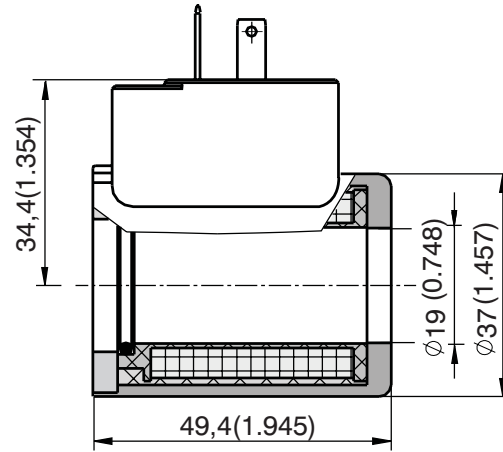

Design version - B

Connector design

E8 (Loose conductors (two insulated cables))

E9 (E8 with quenching diode)

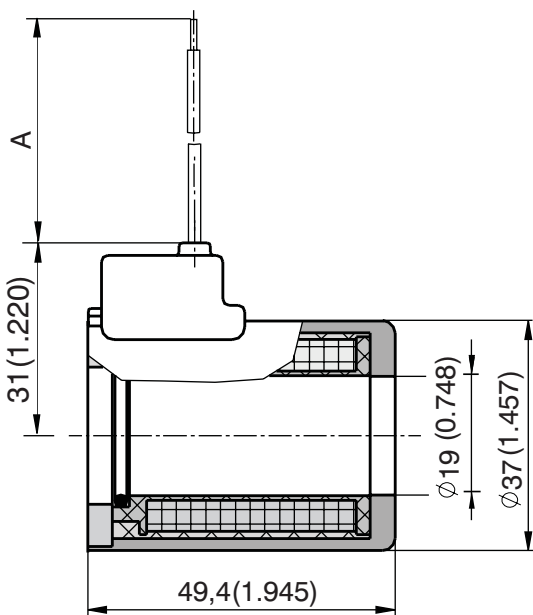

Design version - B

Connector design

E12 (Deutsch DT04-2P)

E13 (E12 with quenching diode)

Protection degree IP67

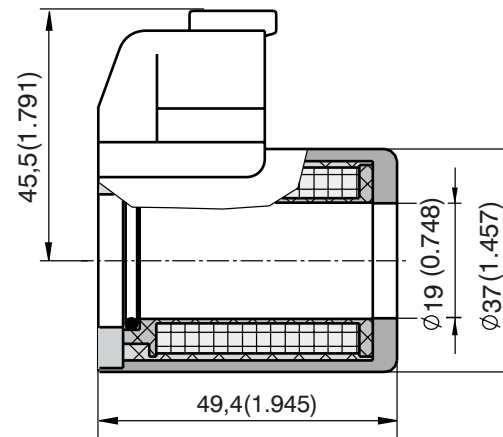

Note:

A = Standard 300 mm, other sizes on demand

Dimensions of Coils C20

Dimensions in millimeters (inches)

Design version - D

Connector design

EW5 - (Wirebox)

Protection degree IP65

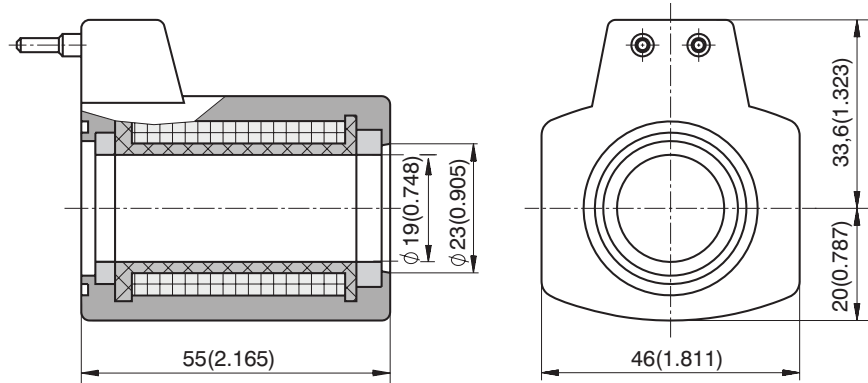

Dimensions of Coils C22

Dimensions in millimeters (inches)

Design version - A

Design version - B

Connector design

E1 (E1 = Connector EN 175301-803-A)

E2 (E2 = E1 with quenching diode)

Protection degree IP65

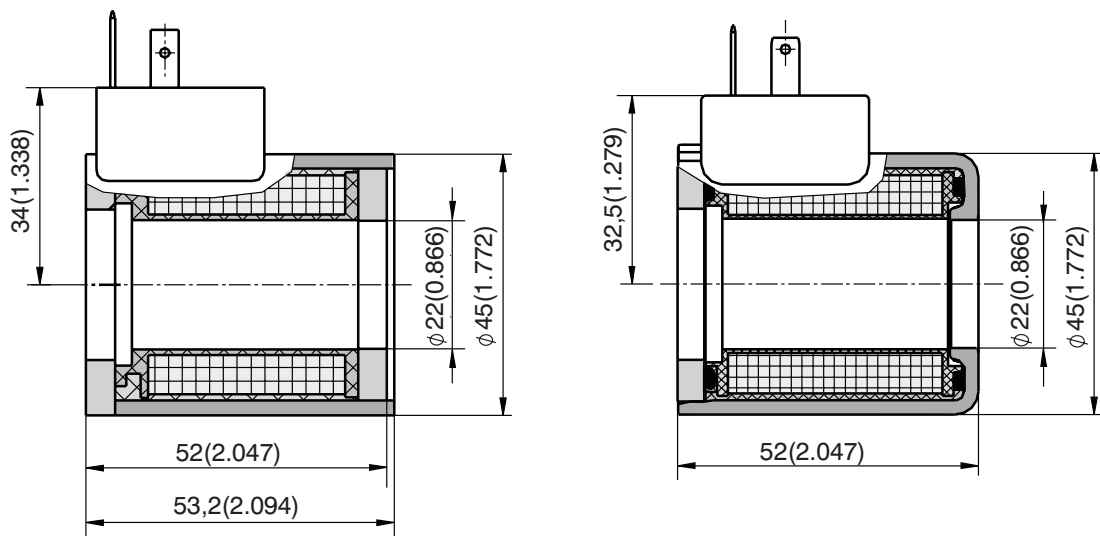

Design version - B

Connector design

E3A (Axial connector AMP Junior Timer (2 pins; male))

E4A (E3A with quenching diode)

Protection degree IP67

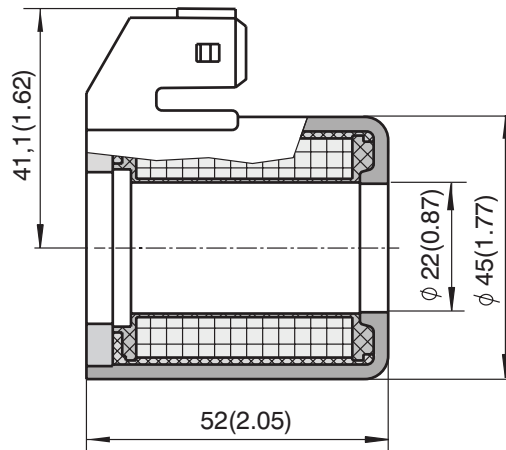

Design version - A

Connector design

E5 (Connector EN 175301-803-A with integrated rectifier)

Protection degree IP65

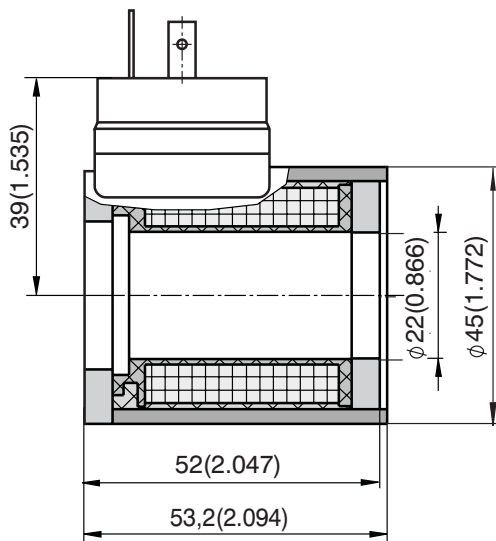

Design version - B

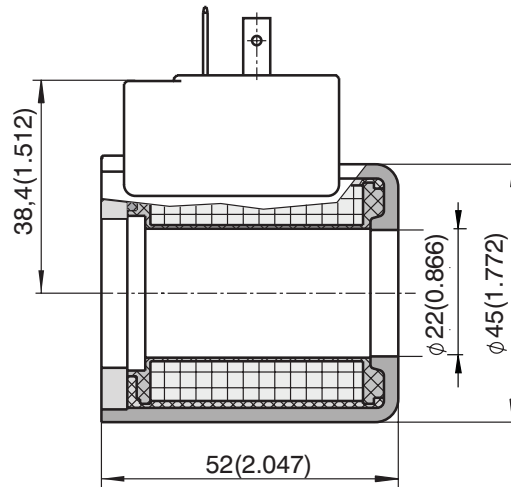

Dimensions of Coils C22

Dimensions in millimeters (inches)

Design version - B

Connector design

E8 (Loose conductors (two insulated cables))

E9 (E8 with quenching diode)

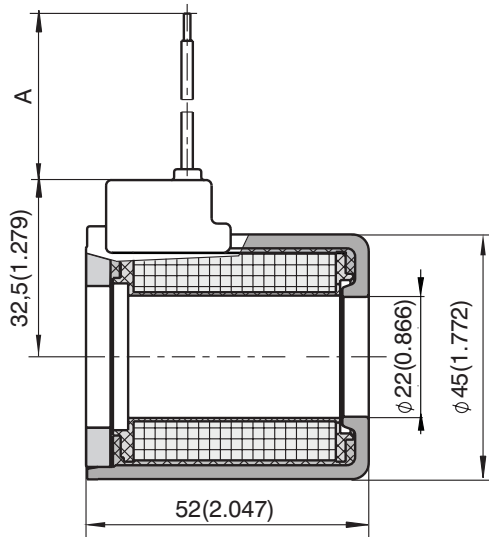

Design version - B

Connector design

E12 (Deutsch DT04-2P)

E13 (E12 with quenching diode)

Protection degree IP67

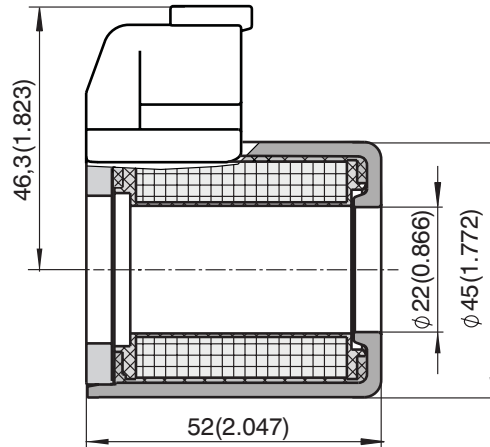

Note:

A = Standard 300 mm, other sizes on demand

Design version - C

Connector design

EW1 - (wirebox)

EW2 - (E3 with quenching diode)

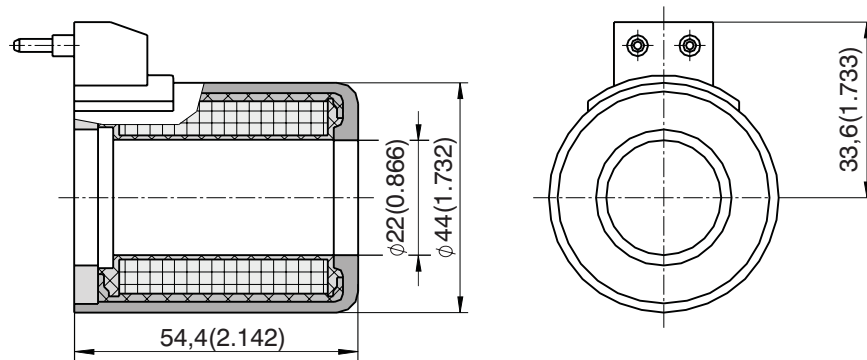

Design version - A

Connector design

- E1 (Connector EN 175301-803-A)
- E2 (E1 with quenching diode)

Protection degree IP65

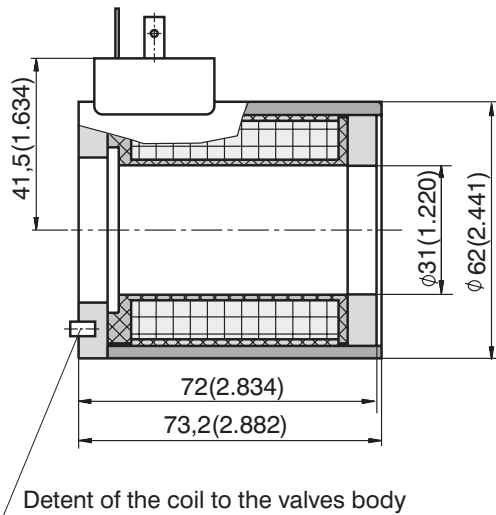

Design version - A

Connector design

- E3 (Connector AMP-Junior-Timer - (2-pins; male)
- E4 (E3 with quenching diode)

Protection degree IP67

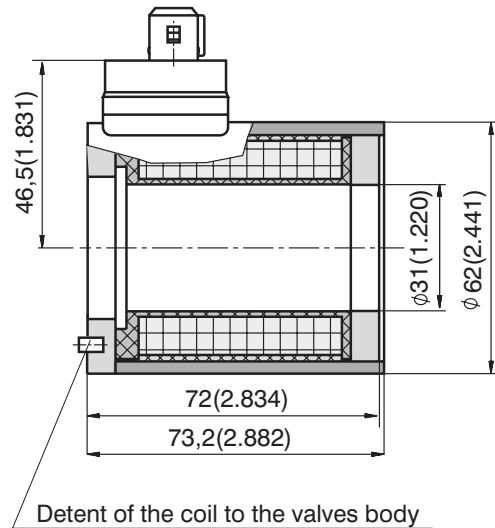

Design version - A

Connector design

- E5 (Connector EN 175301-803-A with integrated rectifier)

Protection degree IP65

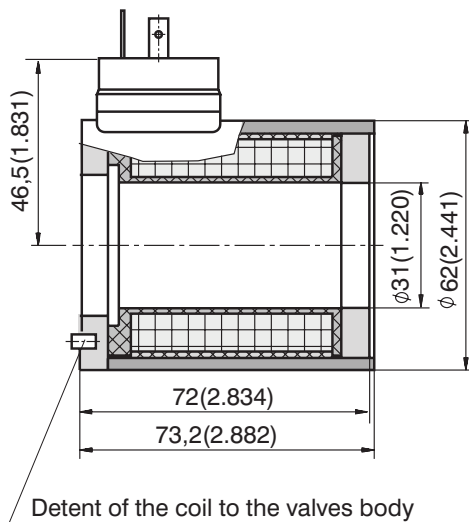

Design version - A

Connector design

- E8 (Loose conductors (two insulated cables))
- E9 (E8 with quenching diode)

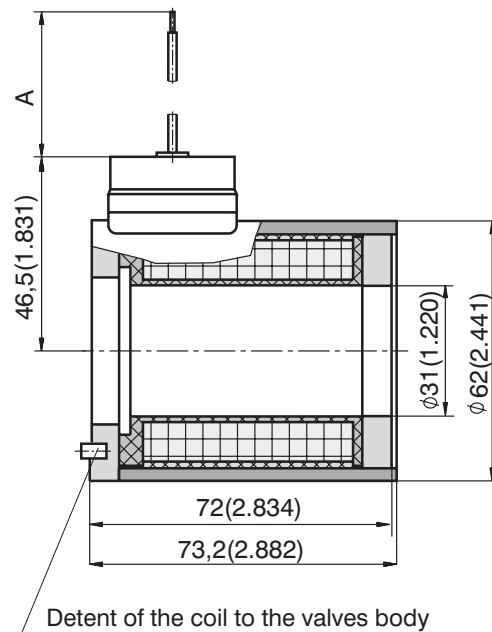

Note:

A = Standard 300 mm, other sizes on demand

Dimension of Coils C31

Dimensions in millimeters (inches)

Design version - A

Connector design

EW1 - (Wirebox)

Protection degree IP65

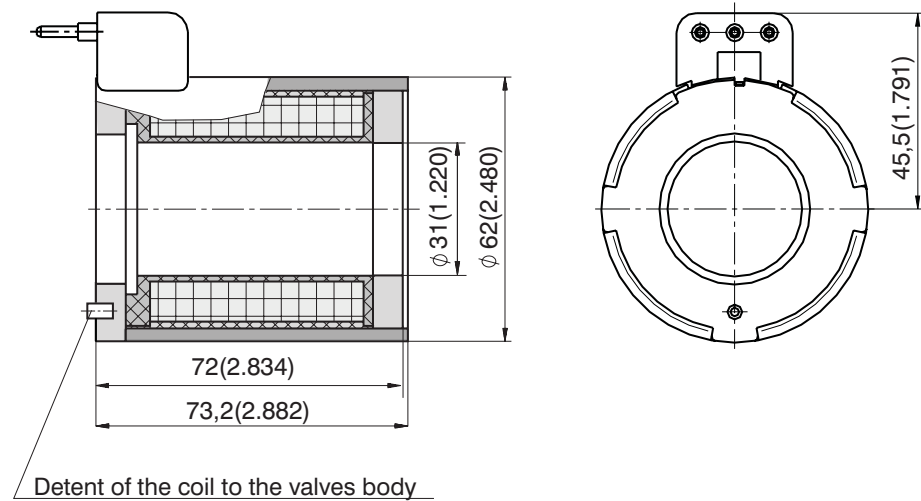

Identification and Survey of the Offered Connectors

Connector	Connector description
E1	Connector EN 175301-803-A
E2	Connector E1 with quenching diode
E3	Connector AMP Junior Timer (2 pins; male)
E4	Connector E3 with quenching diode
E3A	Axial connector AMP Junior Timer (2 pins; male)
E4A	Connector E3A with quenching diode
E5	Connector EN 175301-803-A with integrated rectifier
E51	Connector EN 175301-803-A with integrated recrifier and fast deconnection
E6	Connector Kostal
E7	Connector E6 with quenching diode
E8	Loose conductors (two insulated cables)
E9	E8 with quenching diode
E10	Loose conductors and Deutsch connector DT04-2P (2 pins; male)
E11	E10 witch quenching diode
E12	Connector Deutsch DT04-2P (2 pins; male)
E13	Connector E12 with quenching diode
E14	Connector Spade
E15	Connector E14 with quenching diode
E16	Loose conductors and Metri-Pack connector Series 150 (2 pins; male)
E17	Connector E16 with quenching diode
E18	Loose conductors and Weather-Pack onnector (2 pins; male)
E19	Connector E18 with quenching diode
E20	Loose conductors and Weather-Pack connector (2 pins; male)
E21	Connector E20 with quenching diode
E22	Loose conductors and Econoseal connector (2 pins; male)
E23	Connector E22 with quenching diode
E24	Loose conductors and AMP Junior Timer (2 pins; male)
E25	Connector E24 with quenching diode
EW1	Konektor for Wirebox
EW2	Connector EW1 with quenching diode
EW5	Connector for Wirebox (AC coil)

Survey of Available Connectors and Coils

Connector								
	C14B	C19A	C19B	C20D	C22A	C22B	C22C	C31A
E1	X	X	X		X	X		X
E2	X	X	X		X	X		X
E3			X					X
E3A			X			X		
E4			X					X
E4A			X			X		
E5			X			X		X
E51			X			X		X
E6								
E7								
E8			X			X		X
E9			X			X		X
E10			X			X		X
E11			X			X		X
E12			X			X		
E13			X			X		
E14								
E15								
E16			X			X		X
E17			X			X		X
E18			X			X		X
E19			X			X		X
E20			X			X		X
E21			X			X		X
E22			X			X		X
E23			X			X		X
E24			X			X		X
E25			X			X		X
EW1							X	X
EW2							X	X
EW5				X				

All versions are available with loose conductors (E8 a E9) eventually with loose conductors + connector.
 (E10; E11; E16; E17; E18; E19; E20; E21; E23; E24 a E25) conductors can be protected with braiding (B).

Caution!

- The packaging foil can be recycled.
- All stated data serve for the product description only and in no case should be understood as features guaranteed in terms of law.

ARGO-HYTOS s.r.o. CZ - 543 15 Vrchlabí
 tel.: +420-499-403111, fax: +420-499-403421
 e-mail: sales.cz@argo-hytos.com
 www.argo-hytos.com

- Longer service life thanks to its piston design
- Flanged and screw connection construction
- Easy and lockable setting
- AC and DC power supply option
- Vertical grouping possibility with optionally ordered plate

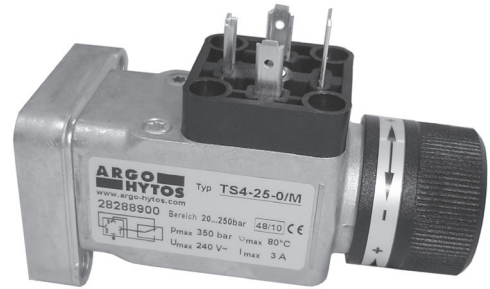
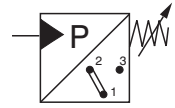

Functional Description

Pressure switches are used for switching hydraulic equipment's signalling or auxiliary circuits. The TS4 switch contacts are controlled by a piston on which front face acts the pressure of the working fluid. Using this design solution guarantees longer service life when compared to membrane switches as the result of possible loss of function due to the membrane's fatigue failure. Changeover contacts can be used for closing and opening the electric circuit. The required pressure is achieved by the hand control, secured in the selected

position by turning the internal hex on the front face of the controller. (Key included.)

The switches are supplied with a flange (DIN ISO 16873) and three M5 screws, or with a versatile screwed connection. Ordering the MTS vertical grouping plate of Size 06 or Size 10 gauge allows flanged lateral surface mounting of the pressure switch to pick-up pressure in one of the channels (A, B, P). The switch can be rotated at 90° steps during its mounting to the lateral wall of the plate.

The connector is not include in the scope of supply and must be ordered as a separate item

Ordering Code

TS4 - <input type="checkbox"/> - <input type="checkbox"/>		
Pressure Switch		
Pressure range		Type
up to 10 160 bar (145 ... 2321 PSI)	16	0 1
up to 20 250 bar (290 ... 3626 PSI)	25	
up to 30 320 bar (435 ... 4641 PSI)	32	
		with flange DIN ISO 16873 with internal thread G1/4

Other pressure stages and connection threads available on request.

Technical Data

Pressure value setting range after closing	bar (PSI)	10 ...160 (145 ... 2321)	20 ... 250 (290 ... 3626)	30 ... 320 (435 ... 4641)
Working fluid maximum pressure	bar (PSI)	350 (5076)		
Connecting dimensions		see Ordering Code		
Hydraulic fluid		Hydraulic oils of power classes (HL, HLP) to DIN 51524		
Maximum degree of fluid contamination		Class 21/18/15 according to ISO 4406		
Fluid temperature range	°C (°F)	+80 (176)		
Ambient temperature	°C (°F)	-10 ...+ 80 (14 ...176)		
Working fluid viscosity range	mm ² / s	20 to 100 (allowable range 12 to 500)		
Frequency of switching maximum	min ⁻¹	100		
Repeatability values at closing	%	± 0,2 % of the measurement range		
Hysteresis after contacts' opening		see Characteristics		
Body material		Die-cast alloy Zn		
Sealing material		PTFE dynamic / NBR static		
Vibration resistance		10 g (10 ... 2000 Hz)		
Shock resistance		30 g (0.066 lbs)		
Electrical connection		Connector EN 175301-803-A (not included in supply)		
Power supply:	category	AC 12 VDE 0660	4 A / 250 VAC	
	category	AC 14 VDE 0660	1 A / 250 VAC	
	category	DC 12 VDE 0660	3 A / 28 VDC	
	category	DC 14 VDE 0660	4 A / 28 VDC	
Enclosure type to EN 60 529		IP 65		
Service life		> 6 mil. switchings		
Mounting position		unrestricted		
Weight	kg (lb)	0,325 (0.716)		

Electrical connection

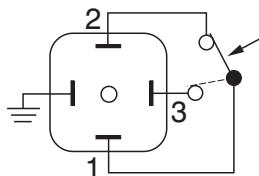

Switching functions:

with the growing pressure the changeover switch opens the circuit of 1 – 2 terminals and closes the circuit of 1 – 3 terminals

Hysteresis after contacts' opening

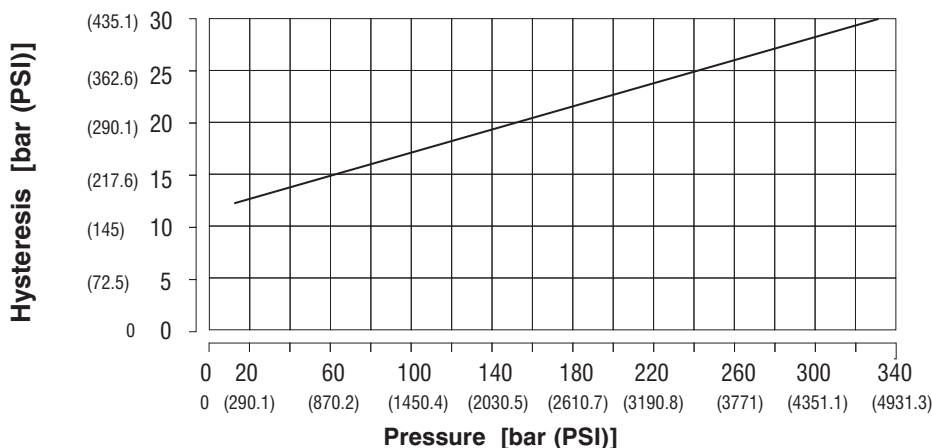

Pressure Switch Dimensions

Dimensions millimetres (inches)

Type TS4-xx-0 (with flange DIN ISO 16 873)

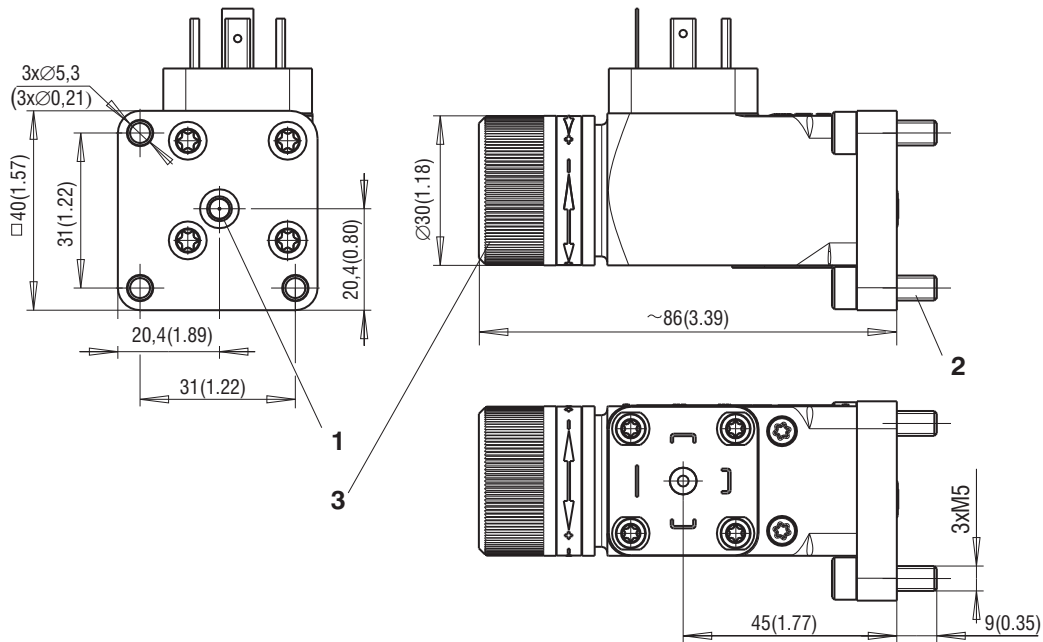

Type TS4-xx-1

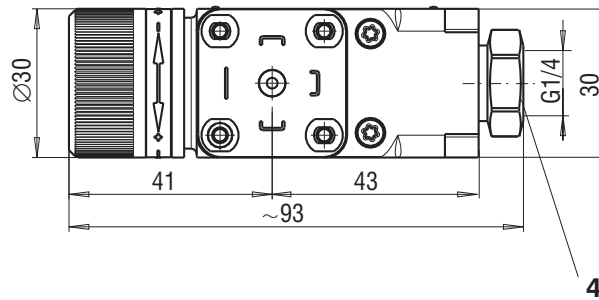

- 1 O-ring 5 x 1,5 - supplied with each switch
- 2 3 pcs. mounting bolts M5x18 (tightening torque 5 Nm(1.124lbf))
- 3 Adjustment element - hand knob
- 4 Internal thread connection - G1/4

Ordering Code of Sandwich Plates

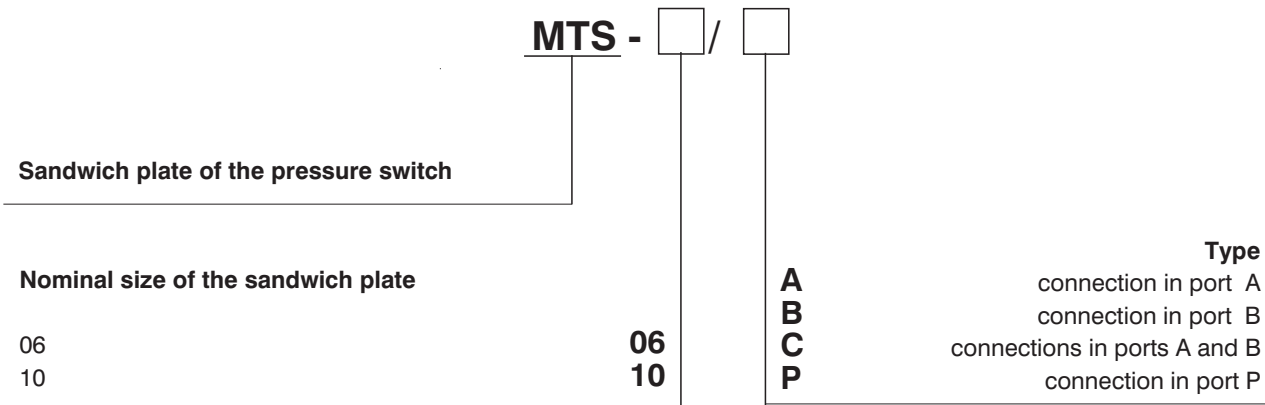

Types of sandwich plates size 06

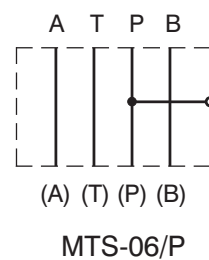
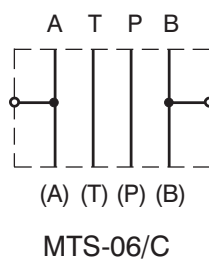
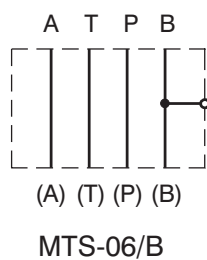
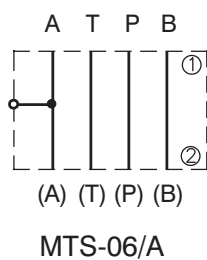

Types of sandwich plates size 10

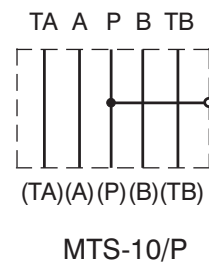
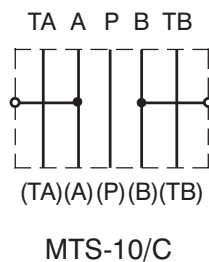
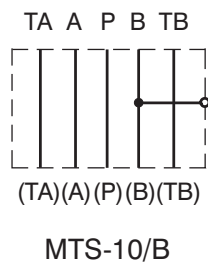
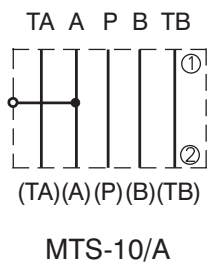

- ① valve side
- ② subplate side

Sandwich Plate Dimensions

Dimensions in millimetres (inches)

MTS - 06/C

- 1 Sandwich plate
- 2 Name plate
- 3 Square ring 9,25 x 1,68 (4 purchase) supplied with each plate
- 4 4 mounting holes
- 5 Mounting surface for TS

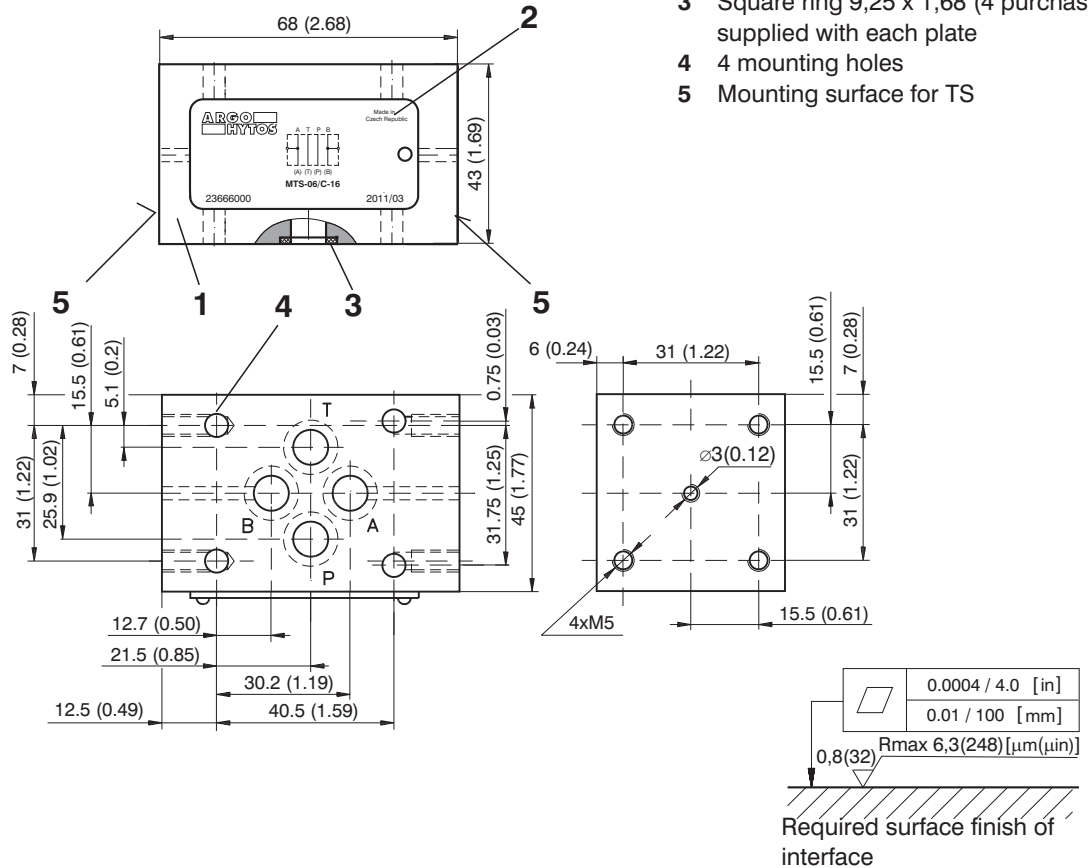

MTS - 10/C

- 1 Sandwich plate
- 2 Name plate
- 3 Square ring 12,42 x 1,68 (5 purchase) supplied with each plate
- 4 4 mounting holes
- 5 Mounting surface for TS

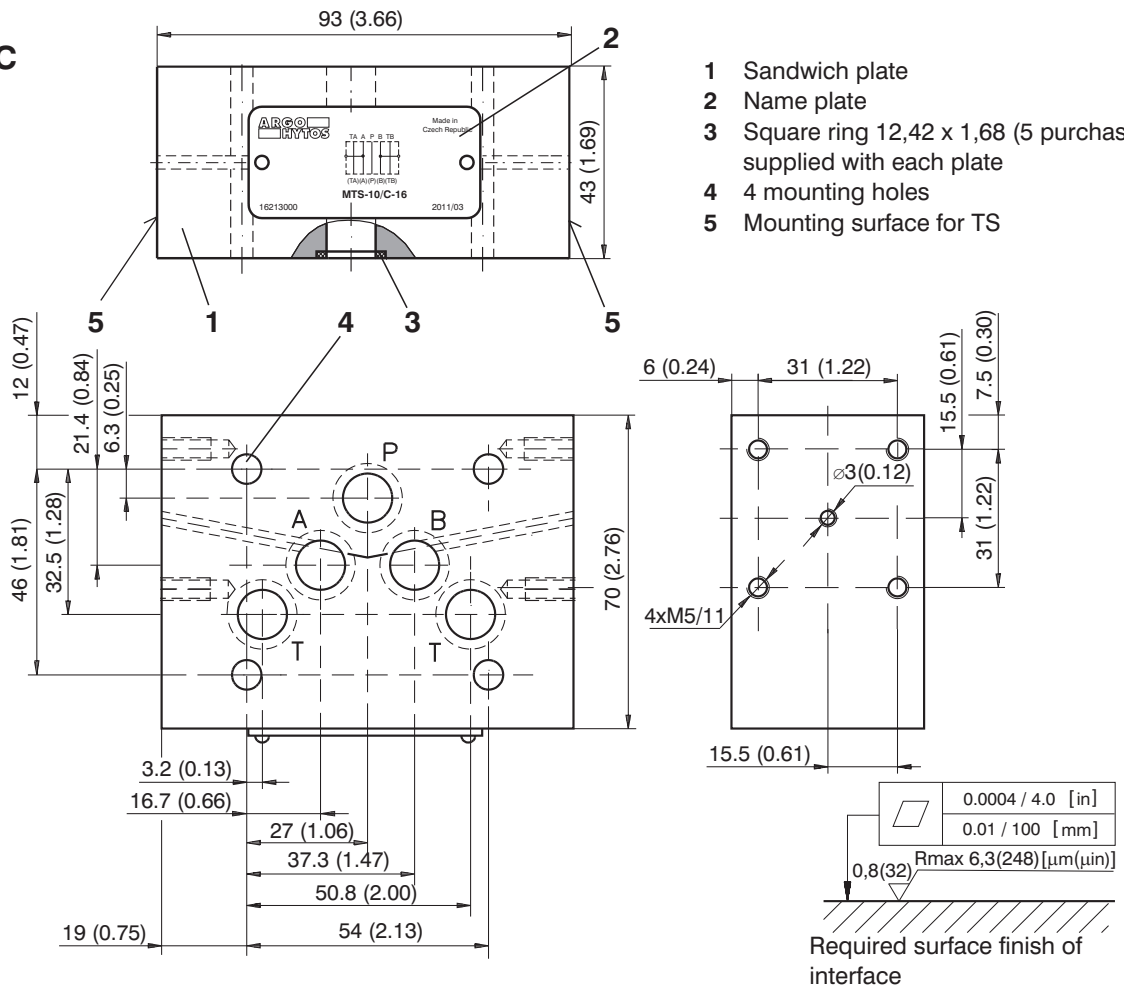

Accessories

Connectors EN 175301-803-A

Type	Solenoid connections	Ordering Number
Connector	Standard	28787900

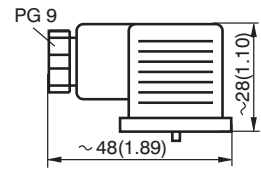

Caution

- The packing foil is recyclable.
- The technical information regarding the product presented in this catalogue is for descriptive purposes only. It should not be construed in any case as a guaranteed representation of the product properties in the sense of the law.

ARGO-HYTOS s.r.o. CZ - 543 15 Vrchlabí
 Tel.: +420-499-403111, Fax: +420-499-403421
 E-mail: sales.cz@argo-hytos.com
 www.argo-hytos.com

p_{max} up to 400 bar (5801 PSI)

- Electronic pressure switch TSE**
 - To monitor the pressure in the circuit and the signalisation switching after reaching pre-set pressure values
 - Stainless steel diaphragm and piezoelectric sensor
 - Compact design in rugged housing
 - FKM seal material (Fluorelastomer)

- Electronic pressure switch TSE**
 - The electronic housing can be rotated in the range of 320°
The sensor body is made of steel, and the electronics housing is made of polyamide PA6.

Design:

- One switching output with adjustable hysteresis
- Two switching outputs (with the hysteresis of approximately 15%)



- Electronic pressure switch TSE-D**
 - The sensor body is made of stainless steel, and the electronics housing is casted of aluminium alloy
 - The display for continuous display of measured pressure values
 - Units' selection for displayed pressure value
 - Possibility of locking the control buttons
 - Selectable time delay setting for contacts closing / opening

Design:

- A switching output with adjustable hysteresis and one analogue output with adjustable value measuring range limits
- Two switched outputs with adjustable hysteresis

Functional Description

Digital pressure switch is used to monitor pressure in the hydraulic or pneumatic circuit and for switching a signalization when the set pressure value is reached. The measuring member is a membrane made of stainless steel. Deflection of the membrane caused by the pressure of the working fluid causes deformation of the piezoelectric sensor. Deformation of a silicon wafer

causes the creation of polarized charge (piezoelectric effect). The resulting voltage on the sensor is proportional to the size of the operating pressure.

In addition the TSE-D switch design features a digital indicator of the instantaneous pressure in the circuit.

Order Code

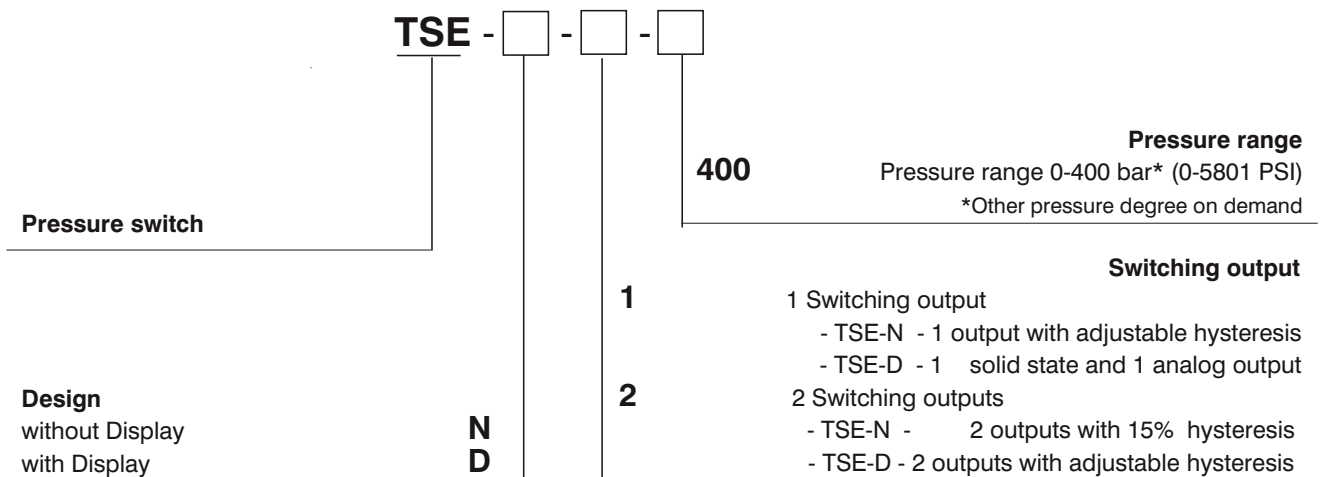

Technical data

Switch design		N	D
Connecting thread		G1/4	
Measuring range	bar (PSI)	0 - 400 (0 - 5801)	
Working fluid		Mineral oil of performance classes HL, HLP (DIN 51524)	
Working fluid temperature	°C (°F)	-10... +70 (+14 ... +158)	
Ambient temperature	°C (°F)	-25... +100 (-13 ... +212)	
Electronics operating temperature	°C (°F)	-25... +80 (-13 ... +176)	-10... +70 (+14 ... +158)
Electric protection (EN 60529)		IP 65	
Degree of protection		III	
Measurement error due to temperature		± 0,2% of the measurement range	
Measurement repeatability	%	+/- 1 of the measuring range	+/- 0,1 of the measuring range
Weight	g (lbs)	ca. 150 (0.33)	ca. 200 (0.44)

Electrical Parameters

Power supply	V DC	15 ... 32	
Power supply connector		4- pin connector, M12x1	
Switching contact (PNP transistor)		max. 200 mA, 100 Hz	max. 500 mA, 100 Hz
Adjustable delayed contacts closing / opening	s	---	0,0 9,9
Measurement frequency	s ⁻¹	200	
Analog output			
Current	mA	4 ... 20	
Maximum load	mA	max. RI = (Ub-12 V) / 20 mA RI = 600 Ohm at Ub = 24V DC	
Load influence		0,3 % / 100 Ω	
Value update frequency	ms	5	
Output voltage	V DC	0 ... 10	
Max. load current	mA	max. 10	
Adjustable range	%	25 .. 100 % of measurement range	
Display		3-character LED red, characters height 100 mm	
Power supply:	mA	50 (no load)	
Maximum vibration level		10 g / 20 - 200 Hz	
Maximum shock level		100 g / 11 ms	

Electrical connection scheme - TSE-N

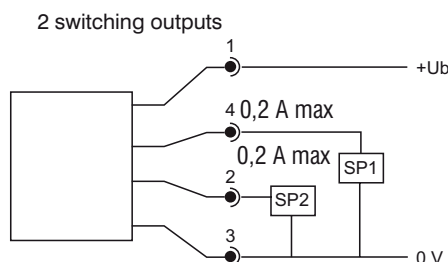
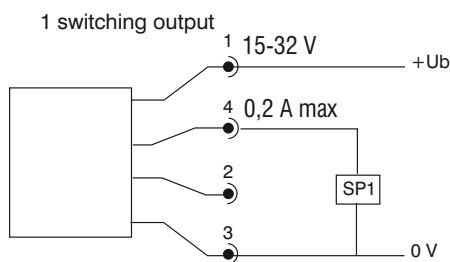

4-pin connector
M12x1

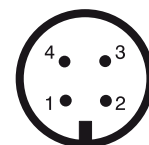

- 1- brown
- 2- white
- 3- blue
- 4- black

Dimension

Dimensions in millimeters (inches)

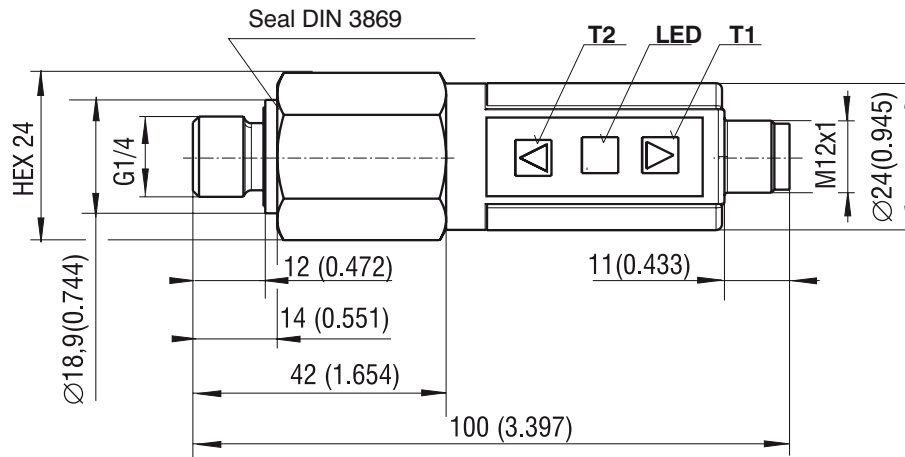

Programming pressure switch TSE-N

a) The switch with one adjustable pressure value for closing and adjustable hysteresis

Programming activation	Press both buttons (T1, T2) for 4 seconds.	LED flashes red and green in turns for 12 seconds, during which time it is possible to set the required value. Then the switch returns to standard mode and the LED lights up green.
Setting the pressure value at contact (SP) closing	Press button T1 for 4 seconds. The pressure switch takes over the current circuit pressure value.	LED lights up red for 4 seconds. LED flashes red three times, then the new value is stored in the memory. LED then lights up green.
Setting the pressure value at contact (RS) opening	Press button T2 for 4 seconds. The pressure switch takes over the current circuit pressure value.	LED lights up green for 4 seconds. LED flashes green three times, then the new value is stored in the memory. LED then lights up green.
Cancelling the set pressure value at contact (SP) closing	Connect the pressure switch to power supply while the button T1 is pressed. Press buttons T1 and T2 for 4 seconds.	LED flashes for 12 seconds in red – green at ratio 1:3. LED then lights up green.
Cancelling the set pressure value at contact (RS) opening	Connect the pressure switch to power supply while the button T2 is pressed. Press buttons T1 and T2 for 4 seconds.	LED flashes for 12 seconds in green - red at ratio 1:3. LED then lights up green.
Error message		LED flashes green and red in turn

Note:

Power supply connections is indicated by green luminous LED. Contacts closing is not indicated visually.

- for switching on function at rising pressure select SP > RS
- for switching on function at dropping pressure select SP < RS



Programming pressure switch TSE-N

b) Switch with two adjustable closing pressure values

Programming activation	Press both buttons (T1, T2) for 4 seconds.	LED flashes red and green in turns for 12 seconds, during which time it is possible to set the required value. Then the switch returns to standard mode and the LED lights up green.
Setting 1. pressure value for contact (SP1) closing	Press button T1 for 4 seconds. The pressure switch takes over the current pressure value in the circuit.	LED lights up red for 4 seconds. LED flashes red three times, then the new value is stored in the memory. LED then lights up green.
Setting 2. pressure value for contact (SP2) closing	Press button T2 for 4 seconds. The pressure switch takes over the current pressure value in the circuit.	LED lights up green for 4 seconds. LED flashes green three times, then the new value is stored in the memory. LED then lights up green.
Cancelling setting 1. pressure value for contact (SP1) closing	Connect the pressure switch to power supply while the button T1 is pressed. Press buttons T1 and T2 for 4 seconds.	LED flashes for 12 seconds in red – green at ratio 1:3. LED then lights up green.
Cancelling setting 2. pressure value for contact (SP2) closing	Connect the pressure switch to power supply while the button T2 is pressed. Press buttons T1 and T2 for 4 seconds.	LED flashes for 12 seconds in green – red at ratio 1:3. LED then lights up green.
Error message		LED flashes green and red in turn

Note:

Contacts' opening hysteresis 15%; using switching on function at rising pressure

Order number

Pressure ranges

0 ... 400 bar (0 ... 5801 PSI)

1 Switching output with adjustable hysteresis

27878300

2 Switching outputs with 15% hysteresis

27940400

Accessories

Description

Order number

Plug connector M12x1, 4-pinns, with screw terminals, foldet

27940900

Plug connector M12x1, 4-pinns, with screw terminals, straight

27940800

Electrical connection scheme - TSE-D

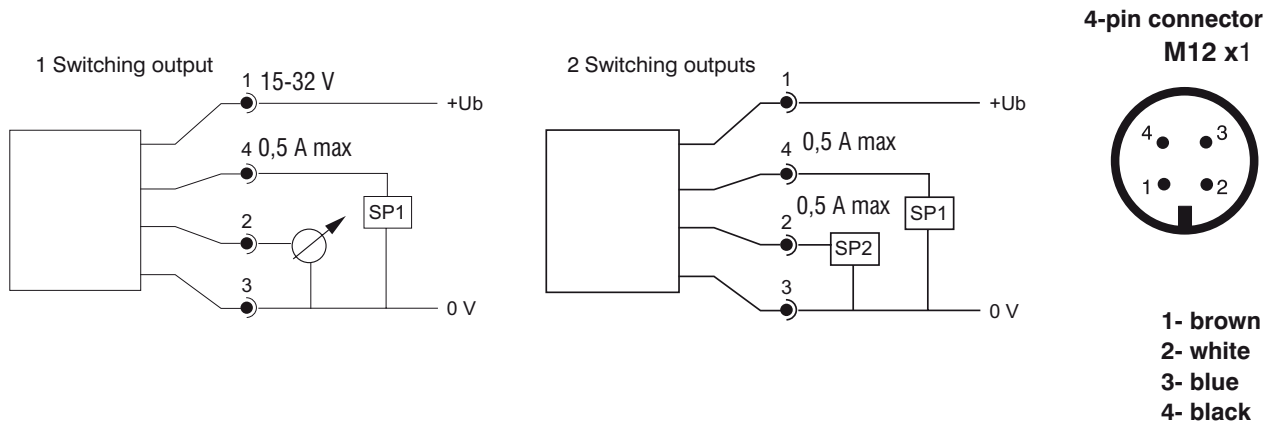

Valve dimensions

dimensions in millimeters (inches)

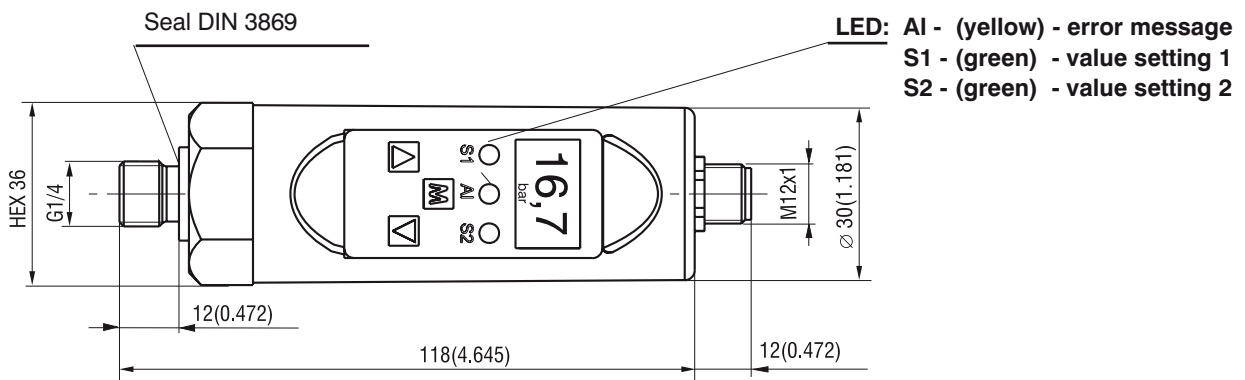

Programming pressure switch TSE-D

1	Entering the menu	After switching on the power supply press button M to enter parameters and functions menu.
2	Dialogue window change	Locate the desired function / parameters setting using the arrow keys. (See table 2. for displayed functions' codes)
3	Activating the dialogue window to set a value or to select a function	Activate the selected dialogue window by pressing button M to perform the required change of value or function.
4	Value setting	Select individual digits using button M (the active position is flashing). Set the numerical value using the arrow keys and confirm with button M. If the value is outside the allowed range the system will return to the previous value.
5	Function setting	Select a function (i.e. the measured values unit) using the buttons and confirm the selection with the button M.
6	Activating the buttons lock	Press both arrow keys simultaneously for 5 seconds. During this period the value on the display must not change. After the lock is active the display will show "Lu0".
7	Lock is active	The value or the function is shown on the display, but it cannot be changed. The display will read "LOK" when an attempt is made to change the value displayed.
8	Buttons lock deactivation	Press both arrow keys simultaneously for 5 seconds. During this period the value on the display must not change. After the lock is active the display will show "Lu0". After deactivating the lock the display will show a message reading "Lu2".
9	Programming exit	Press the button M for 5 seconds. The switch will return to the measurement mode.
10	Automatic return to measuring mode	After two minutes from the last setting the switch will automatically return to the measurement mode. Unconfirmed changes will be ignored.

List of menu items		
Symbol	Value	Function Description
	0 ... 400 (0 ... 5801)	Display shows the current measured pressure value
ACt		After pressing the M button the switch signals entry to menu and the possibility of a new setting - update. Now you can use the arrow keys to navigate the menu.
S I		Selecting units for displayed values nbr = mbar PSH = PSI x 10 hPo = hPa bor = bar PS I = PSI nPo = MPa
Und		Showing unit on display on = the displaying is activated (the unit is displayed after 30 seconds) oFF = showing the unit on the display is switched off.
SP I		Switch function selection u In = window technology Contacts SP1 are closed in the set values' interval of the ON1 - OF1, when the function HFS is set, or are disabled in this interval when the function LFS is set. Std = standard evaluation The contacts SP1 close when the preset value ON1 is reached and open when the pressure drops to the pre-set value of OF1 provided the function HFS is set. When the function LFS is set the contacts SP1 are closed until the value ON1 is reached, when they open. When the pressure drops to the value OF1 they close again. Err = erroneous output (removal of contacts from activity).
on I	0 ...XXX	Setting the pressure value to close the contact SP1 .
OF I	0 ...XXX	Setting the pressure value to open the contact SP1 .
dS I	0.0 s ...9.9 s	Setting the contact SP1 closure time delay in seconds after reaching the pre-set pressure value.
dr I	0.0 s ...9.9 s	Setting the contact SP1 time delay for its opening in seconds after reaching the pre-set pressure value.
lu I		SP1 switch output function exchange HFS (high-level-fail-save) – contact SP1 closes after reaching the upper limit of the pressure value. LFS (low-level-fail –save) – contact SP1 closes after pressure drops to its lower limit.
Note: After changing the units from PSI to Bars and vice versa it is necessary to set the contacts' closing and opening values.		
Only for types with two closing contacts		
SP 2		Switch function selection u In = window technology Contacts SP2 are closed in the set values' interval of the ON2 - OF2, when the function HFS is set, or are disabled in this interval when the function LFS is set. Std = standard evaluation The contacts SP2 close when the preset value ON2 is reached and open when the pressure drops to the pre-set value of OF2 provided the function HFS is set. When the function LFS is set the contacts SP2 are closed until the value ON2 is reached, when they open. When the pressure drops to the value OF2 they close again. Err = erroneous output (removal of contacts from activity).
on 2	0 ...XXX	Setting the pressure value to close the contact SP2 .
OF 2	0 ...XXX	Setting the pressure value to open the contact SP2 .
dS 2	0.0 s ...9.9 s	Setting the contact SP2 closure time delay in seconds after reaching the pre-set pressure value.
dr 2	0.0 s ...9.9 s	Setting the contact SP2 time delay for its opening in seconds after reaching the pre-set pressure value.
lu 2		SP2 switch output function exchange HFS (high-level-fail-save) – contact SP2 closes after reaching the upper limit of the pressure value. LFS (low-level-fail –save) – contact SP2 closes after pressure drops to its lower limit.

Oly for types with analogue output		
A02	0 ...XXX	Analogue output range setting - initial values (i.e. 0 bar = 4 mA)
R0F	0 ...XXX	Analogue output range setting – final values (i.e. 400 bar [5801 PSI] = 20 mA) (If the pressure drops below 25% of the measurement range the analogue output disconnects.)
nAH	0 ...XXX	The highest value " Max " display (maximum of 125% of the range)
CLr		Deleting the stored maximum value NO = do not delete YES = deletion confirmation
Err		Erros messages OH = no error nAH = measurement range in the positive direction exceeded n In = measurement range in the negative direction exceeded SEn = sensor error SP1 = switched output 1 error SP2 = switched output 2 error dAt = data error PrC = program error CAL = calibration error Ono = analog output error

Note:

After changing the units from PSI to Bars and vice versa it is necessary to set the contacts' closing values again.

Order number

Pressure ranges	0 ... 400 bar (0 ... 5801 PSI)
1 switching output and 1 analogue output 4 ... 20mA	27878600
2 switching outputs	27878500

Accesories

Description	Order number
Adapter G1/4 male thread IG G1/4 for optimum alignment of pressure switch	27885100
Plug connector M12x1,4-pinns, with screw terminals, folded	27940900
Plug connector M12x1,4-pinns, with screw terminals, straight	27940800

Output function exchange

Standard evaluation for contacts SP1 A SP2

Output function HFS

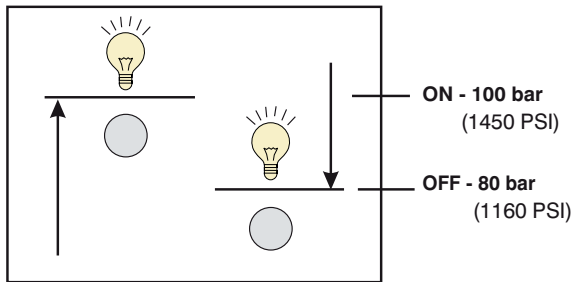

Output function LFS

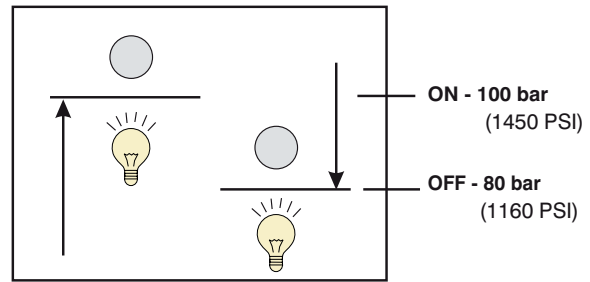

Windows function for contacts SP1 A SP2

Output function HFS

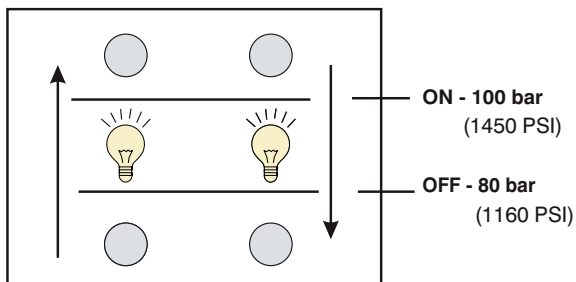

Output function LFS

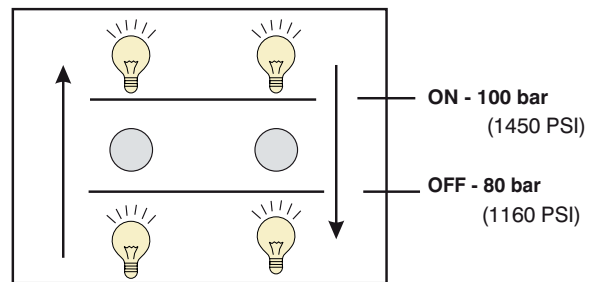

Closed contacts of the switch



Open contacts of the switch

Notice!

- The switch must not be installed on equipment, of which working fluid maximum allowable pressure exceeds the maximum allowable switch pressure indicated on the label. The allowed range of temperatures must not be also exceeded.
- The sensor power supply values must conform to the specification listed in the catalogue.
- The switch must be protected against excessive vibrations and shocks during handling and transport, as these may lead to damage of internal components and malfunction.
- It is forbidden to use damaged switch or connect it to the power supply source with damaged cable.
- Installation may be carried out only by adequately trained person.
- The switch can be installed or removed only when it is disconnected from the power supply and switched off equipment (without pressure).
- To tighten the switch use the hex size 24 / 36, 45 Nm torque.
- The surface of the switch can be heated by the working fluid to higher temperature.
- The switch may not be used as a safety element in the pressure circuits within the meaning of Directive DGR 97/23/EC.
- The pressure switch does not belong to municipal waste, but must be disposed of in accordance with regional regulations for disposal of products with electronic components.

- The packing foil is recyclable.
- The cover can be sent back to the manufacturer.
- The technical information regarding the product presented in this catalogue is for descriptive purposes only. It should not be construed in any case as a guaranteed representation of the product properties in the sense of the law.

ARGO-HYTOS s.r.o. CZ - 543 15 Vrchlabí
 Tel.: +420-499-403111, Fax: +420-499-403421
 E-Mail: sales.cz@argo-hytos.com
 www.argo-hytos.com

- Simple and reliable design
- Good efficiency
- Cartridge design to mount in manifold
- The hand lever position can be rotated 360° around

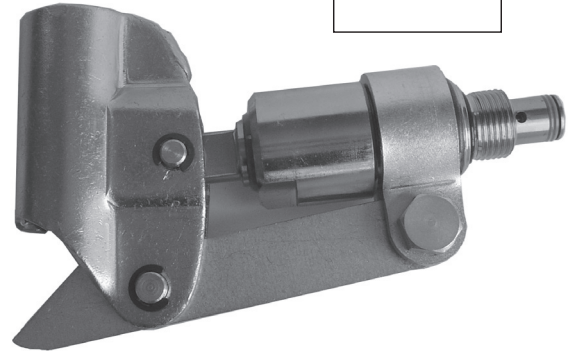
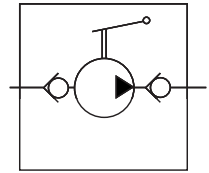

Functional Description

RC 3/4-16-UNF

A manually-operated single-acting piston pump with two non-return valves. As the piston (1) moves up, the negative pressure is formed and it closes the discharge valve (2), the pump inlet valve (3) opens and the fluid is drawn-in through the radial opening under the pump piston. Once the top dead centre is achieved, the piston moves down and increasing fluid pressure closes the inlet valve and opens the discharge valve. The fluid is under the pressure in proportion to the action of force on the lever and thus pushed out in the axial direction

RC M22x1,5

A manually-operated single-acting piston pump with two non-return valves. The function of the non-return discharge valve is substituted by a special rubber cup (2). As the piston (1) moves up, the negative pressure is formed and it opens the inlet valve (3), while the clinging special cup closes the radial discharge opening; the fluid is drawn-in through the axial opening under the pump piston. Once the top dead centre is achieved, the piston moves down. The increasing fluid pressure closes the inlet valve and raises the special sealing cup. The fluid is under the pressure in proportion to the action of force on the lever and thus pushed out in the axial

The control lever with a 500 mm (19.68 in) long handle and set of spare gaskets can be ordered as accessories.

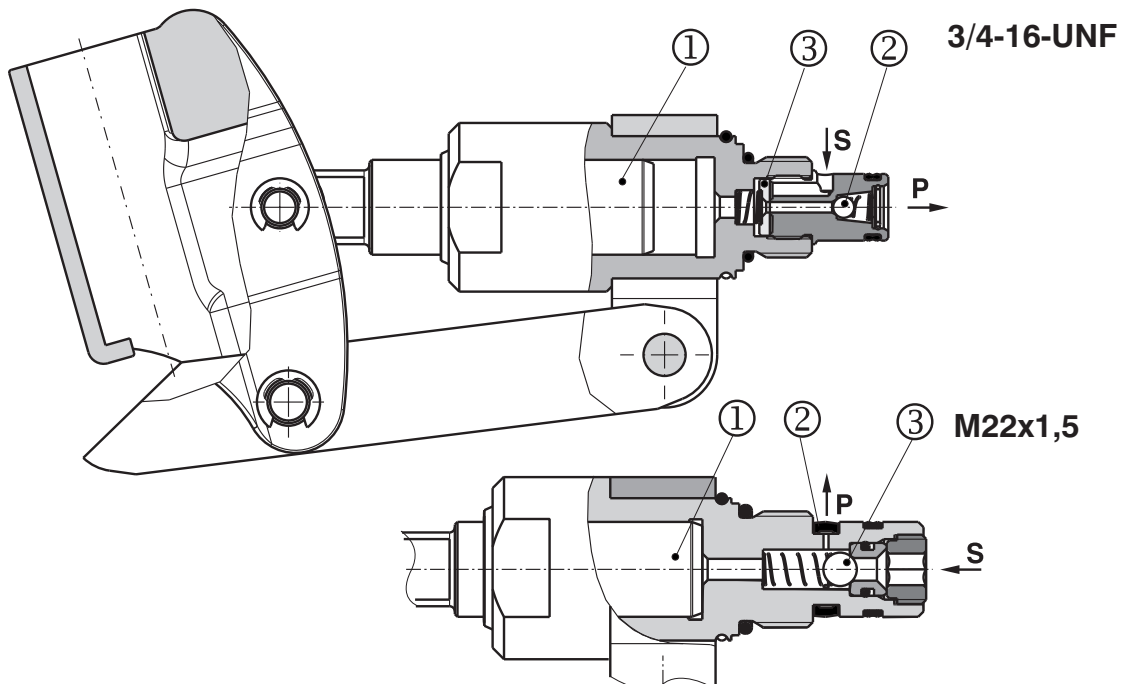

Ordering Code

	RC	-	<input type="checkbox"/>
Piston Pump			
Cartridge thread	3/4-16-UNF M22x1,5		
		No designation	Seals NBR

Technical Data

Cartridge thread		3/4-16 UNF - 2A	M22 x 1,5
Maximum pressure	bar (PSI)	160 (2321)	
Max. circuit pressure	bar (PSI)	250 (3626)	
Max. force on the lever (L = 500mm (19.68 in))	N (lbf)	350 (78.7)	
Quantity of oil pushed out per one double-stroke	cm ³	7±1	5 ± 1
Hydraulic fluid		Hydraulic oils of power classes (HL, HLP) to DIN 51524	
Fluid temperature range	°C (°F)	-20 do +100 (-22 ... +212)	
Ambient temperature, max.	°C (°F)	-20 do +50 (-22 ... +122)	
Viscosity range	mm ² / s (SUS)	20 ... 400 (98 ... 1840)	
Maximum degree of fluid contamination		Class 21/18/15 according to ISO 4406	
Valve tightening torque	Nm (lbf.ft)	30 +5 (22.13+3.68)	
Weight	kg(lbs)	0,72 (1.587)	0.70 (1.543)
Mounting position		unrestricted	

Valve Dimensions

Dimensions in millimeters (inches)

3/4-16-UNF

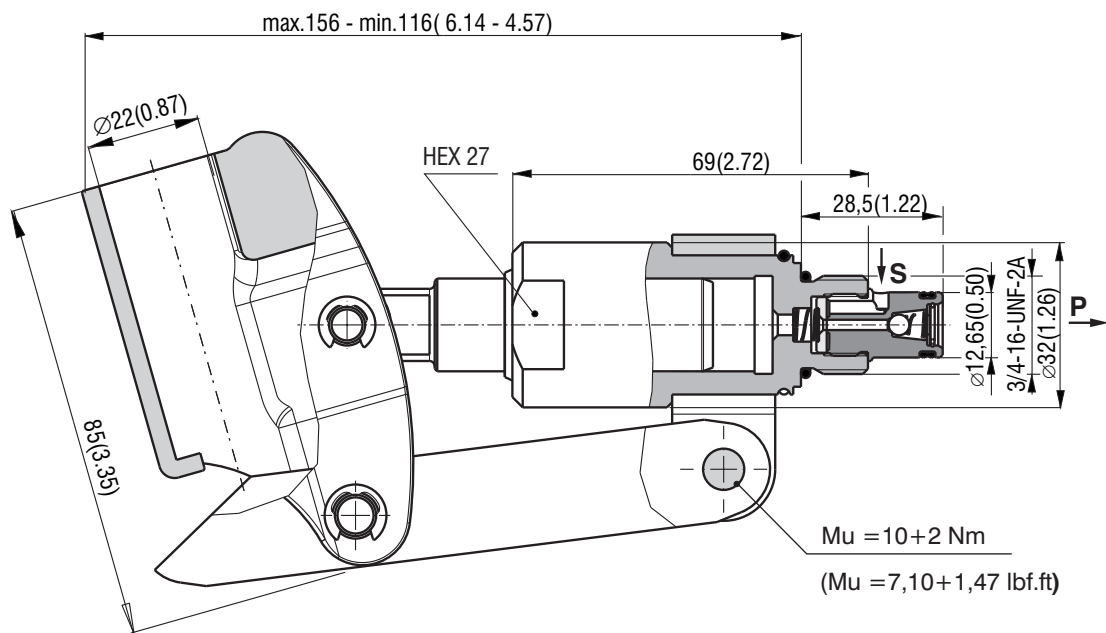

M22x1,5

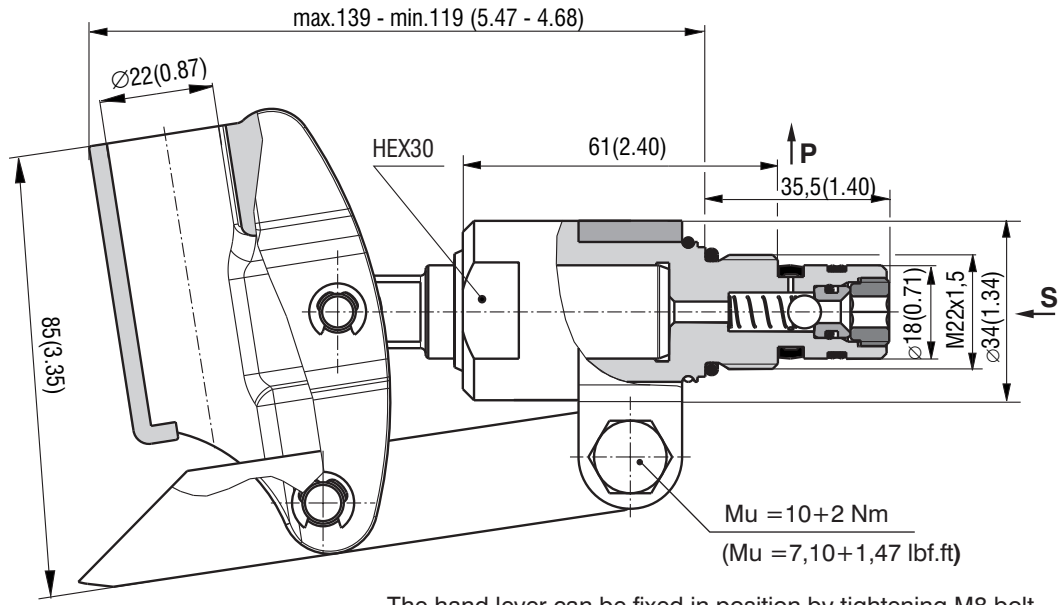

The hand lever can be fixed in position by tightening M8 bolt.

Cavity

Dimensions in millimeters (inches)

3/4-16-UNF

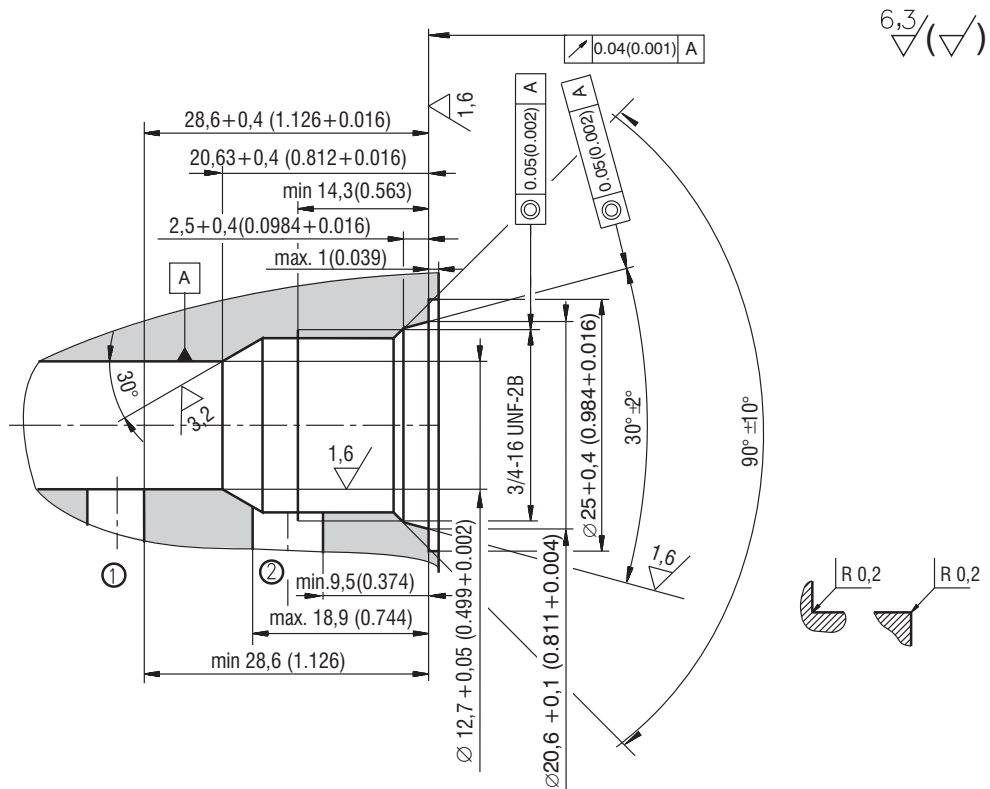

8

M22x1,5

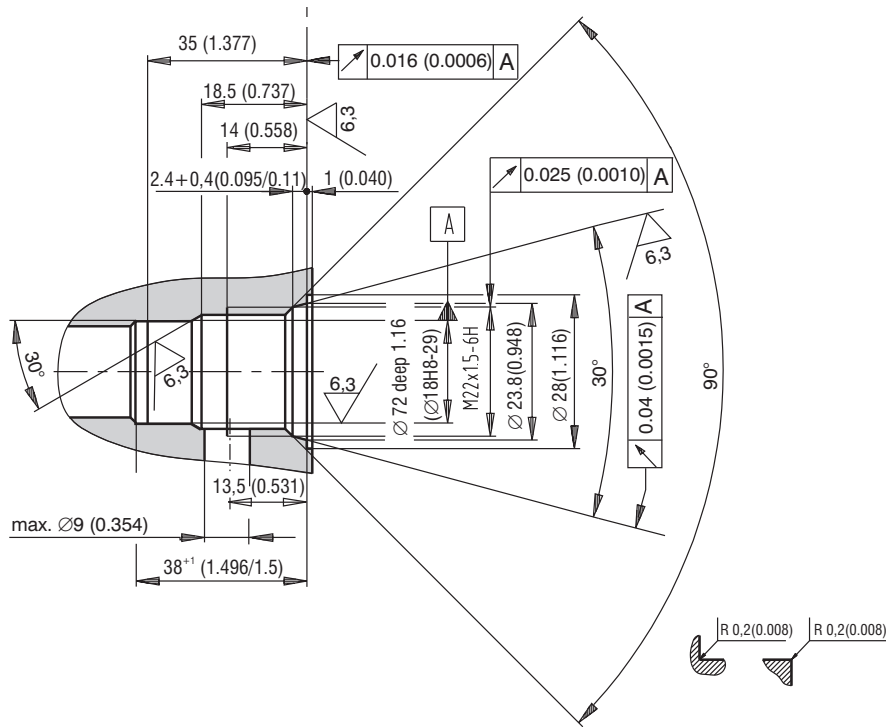

Spare Parts

Solenoid	Dimensions , quantity			Ordering number
	Dualseal - PU	O-ring - NBR	Rubber cup	
RC 3/4-16UNF	10,3 x 12,7 x 3,1 (1pc)	17 x 1,8 (1pc)	-	20776700
RC M22x1.5	15,6 x 18 x 3,4 (1pc)	19,4 x 2,1 (1pc)	11.6 x 19 x 4.6 (1pc)	29517000
Control lever RC	Ø 12, L = 500 (1pc)			23476200

Caution!

- The packing foil is recyclable.
- The technical information regarding the product presented in this catalogue is for descriptive purposes only. It should not be construed in any case as a guaranteed representation of the product properties in the sense of the law.

ARGO-HYTOS s.r.o. CZ - 543 15 Vrchlabí
 Tel.: +420-499-403 111
 E-mail: info.cz@argo-hytos.com
 www.argo-hytos.com

- Basic manifold for hydraulic systems**
- 6 pressure ranges**
- Installation dimensions to ISO 4401-AB-03-4-A,
ISO 4401-AC-05-4-A, DIN 24 340-A6
and DIN 24 340-A10**

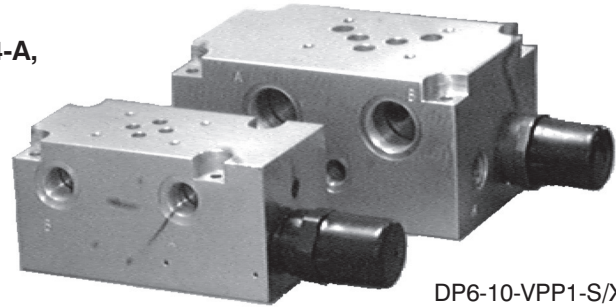
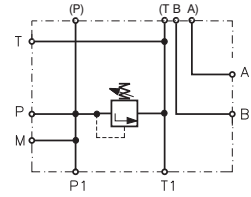

DP6-06-VPP1-S/XX

DP6-10-VPP1-S/XX

Functional Description

Basic manifolds DP6 are used for hydraulic systems which require only one directional valve assembly. With regard to its versatile connection possibilities, it is suitable either for horizontal mounting of the pump drive unit on the tank cover, or for vertical arrangement with the pump situated in the tank under the oil level.

The steel manifold can be supplied in two sizes. A direct operated pressure relief valve is available in six pressure ranges.

The basic surface treatment of the block is zinc coating.

Ordering Code

DP6 - <input type="text"/> - <input type="text"/> - <input type="text"/> / <input type="text"/>	
<p>Basic block</p> <hr/> <p>Nominal size 06 mm 06 10 mm 10</p> <hr/> <p>Pressure relief valve VPP1 - 06, 10 VPP1 VPP2 - 06 VPP2</p>	<p style="text-align: center;">2.5 6.3 10 16 25 32</p> <hr/> <p style="text-align: center;">S R</p>
	<p style="text-align: right;">Druckstufe up to 25 bar up to 63 bar up to 100 bar up to 160 bar up to 250 bar up to 320 bar</p> <hr/> <p style="text-align: right;">Adjustment element Screw with inside HEX 5 Hand knob</p>

Valve Dimensions

Dimensions in millimeters

DP6-06-VPP1-S/XX

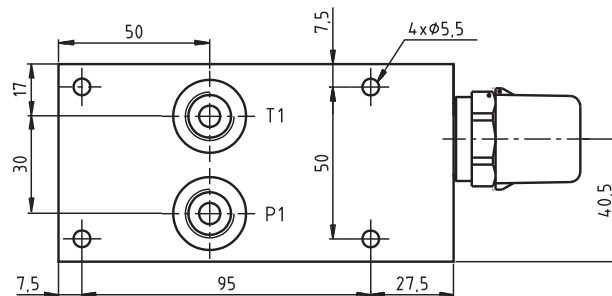
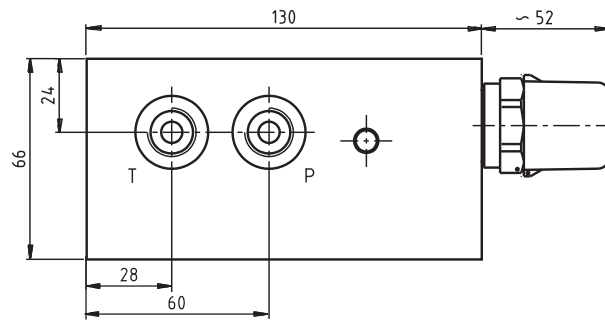
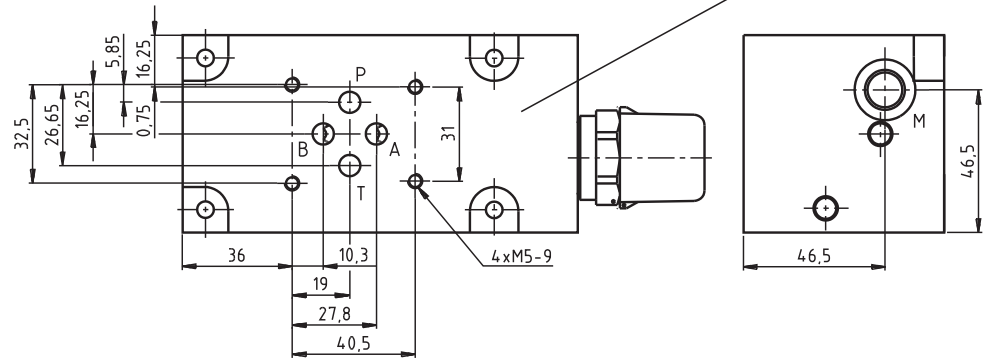
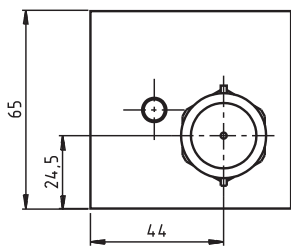
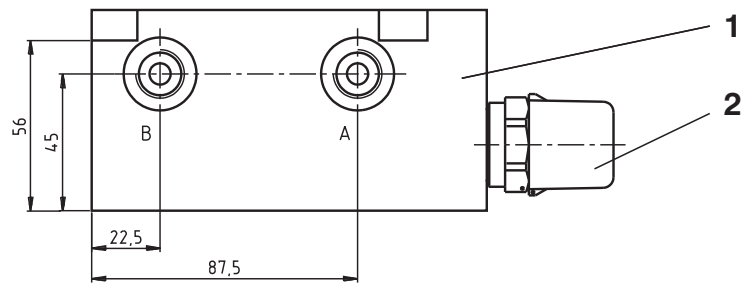
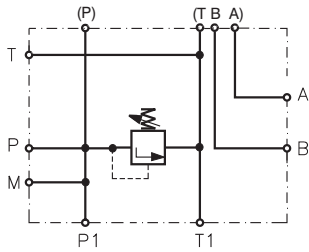

- 1 Basic block
- 2 Pressure relief valve
- 3 4 mounting holes

Port	A	B	P	T	P1	T1	M
Thread	G3/8	G3/8	G3/8	G3/8	G3/8	G3/8	G1/4
Counterbore	Ø24	Ø24)	Ø24	Ø24	Ø28	Ø28	Ø20
Depth of counterbore	1	1	1	1	5.5	5.5	1

Valve Dimensions

Dimensions in millimeters

DP6-10-VPP1-S/XX

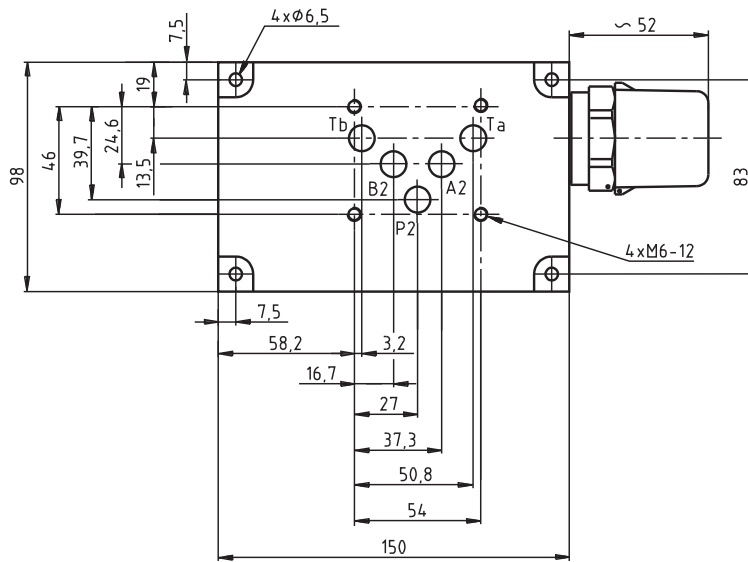
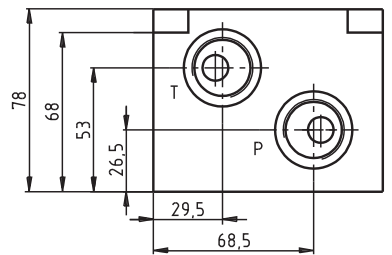
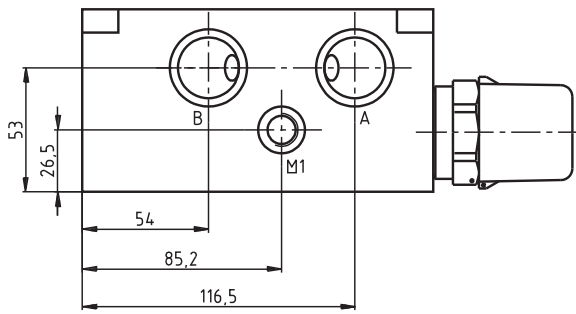
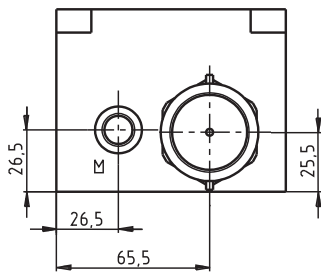
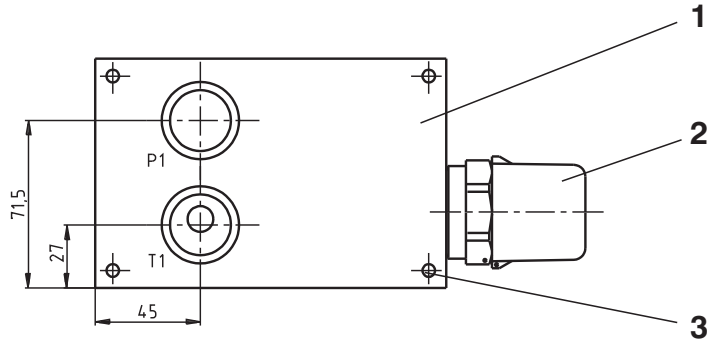
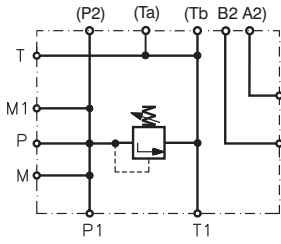

- 1 Basic block
- 2 Pressure relief valve
- 3 4 mounting holes

Port	A	B	P	T	P1	T1	M	M1
Thread	G3/4	G3/4	G3/4	G3/4	G3/4	G3/4	G1/4	G1/4
Counterbore	Ø33	Ø33	Ø33	Ø33	Ø38	Ø38	Ø38	Ø20
Depth of counterbore	1	1	1	1	5.5	5.5	1	1

Caution!

- The packing foil is recyclable.
- The technical information regarding the product presented in this catalogue is for descriptive purposes only. It should not be construed in any case as a guaranteed representation of the product properties in the sense of the law.

ARGO-HYTOS s.r.o. CZ - 543 15 Vrchlabí
Tel.: +420-499-403111, Fax: +420-499-403421
E-mail: sales.cz@argo-hytos.com
www.argo-hytos.com

- For in-line mounting of hydraulic valves
- Parallel connection of ports P and T
- 1 ...8 sections possible
- Installation dimensions size 04 to ISO 4401 CETOP - RP 121H
- Aluminium EN AW - 7075 T6

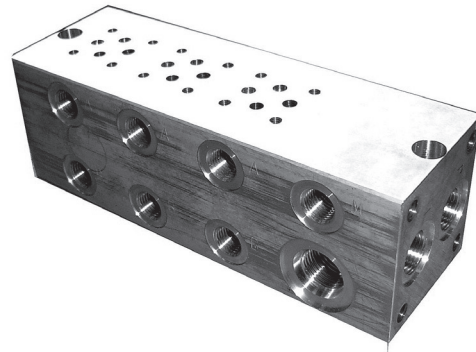

Ordering Code

DR1-04 <input type="checkbox"/> / <input type="checkbox"/> <input type="checkbox"/>			
In-line connecting plate	<table border="0"> <tr> <td style="text-align: center; vertical-align: top;"> 0 1 2 </td> <td style="padding-left: 10px;"> without cavities* with one cavity for pressure valve with two cavities for pressure relief and unloading valves </td> </tr> </table>	0 1 2	without cavities* with one cavity for pressure valve with two cavities for pressure relief and unloading valves
0 1 2	without cavities* with one cavity for pressure valve with two cavities for pressure relief and unloading valves		
Nominal size	<table border="0"> <tr> <td style="text-align: center; vertical-align: top;"> 1 2 3 4 5 6 7 8 </td> <td style="padding-left: 10px;"> Number of sections 1 section 2 sections 3 sections 4 sections 5 sections 6 sections 7 sections 8 sections </td> </tr> </table>	1 2 3 4 5 6 7 8	Number of sections 1 section 2 sections 3 sections 4 sections 5 sections 6 sections 7 sections 8 sections
1 2 3 4 5 6 7 8	Number of sections 1 section 2 sections 3 sections 4 sections 5 sections 6 sections 7 sections 8 sections		
Without append	Without designation		

*Version DR1-04/0 only for 2-8 sections

Connection

DR1 04/ 0

P, T.....G3/8
A, B.....G1/4

DR1 04/ 1

P, T.....G3/8
A, B.....G1/4
M.....G1/4
valve cavity 3/4-16-UNF
(description 08-01-0-0)

DR1 04/ 2

P, T.....G3/8
A, B.....G1/4
M.....G1/4
valve cavity 3/4-16-UNF
(description 08-01-0-0)

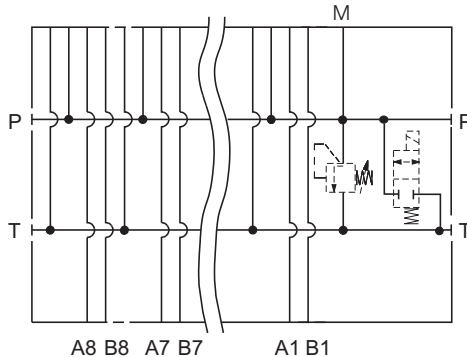
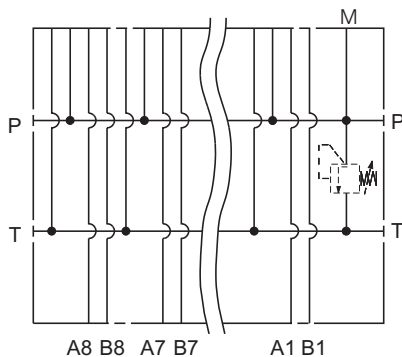
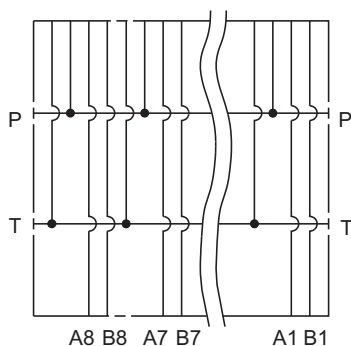

Cavities

Dimensions in millimeters (inches)

Cavity for valves 3/4-16- UNF, cavity A2

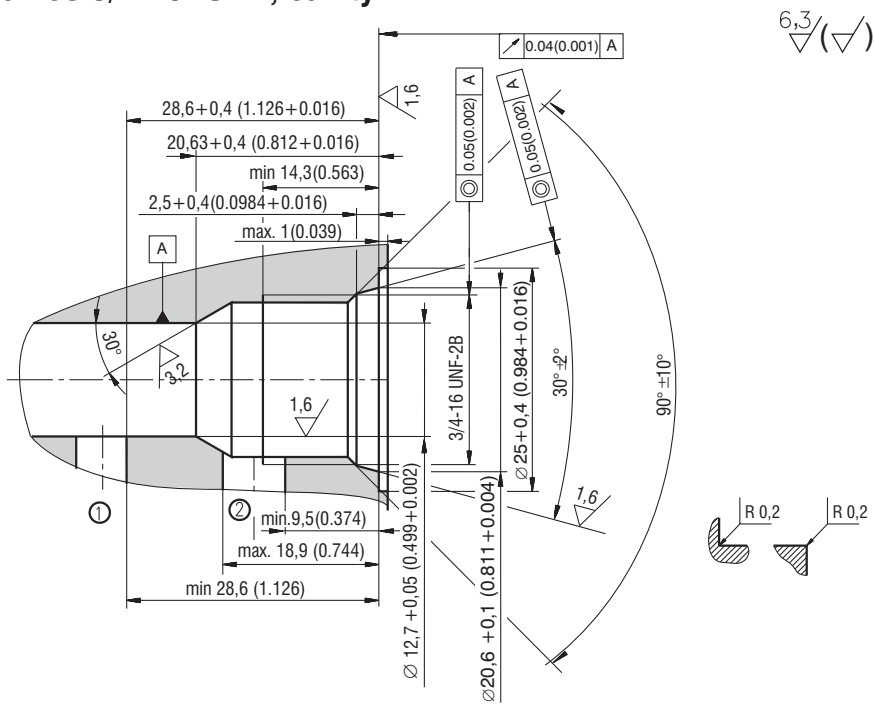

Port cavity G1/4...A, B, M

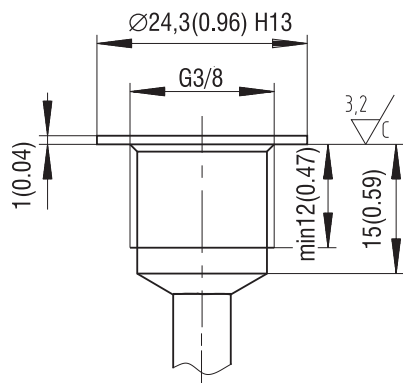

Port cavity G3/8... P, T

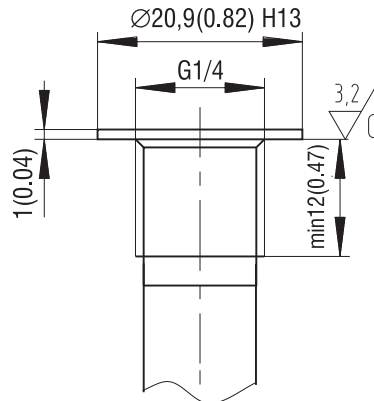

Valve Dimensions

Dimensions in millimeters (inches)

DR1 04 / 0

number of sections 2-8

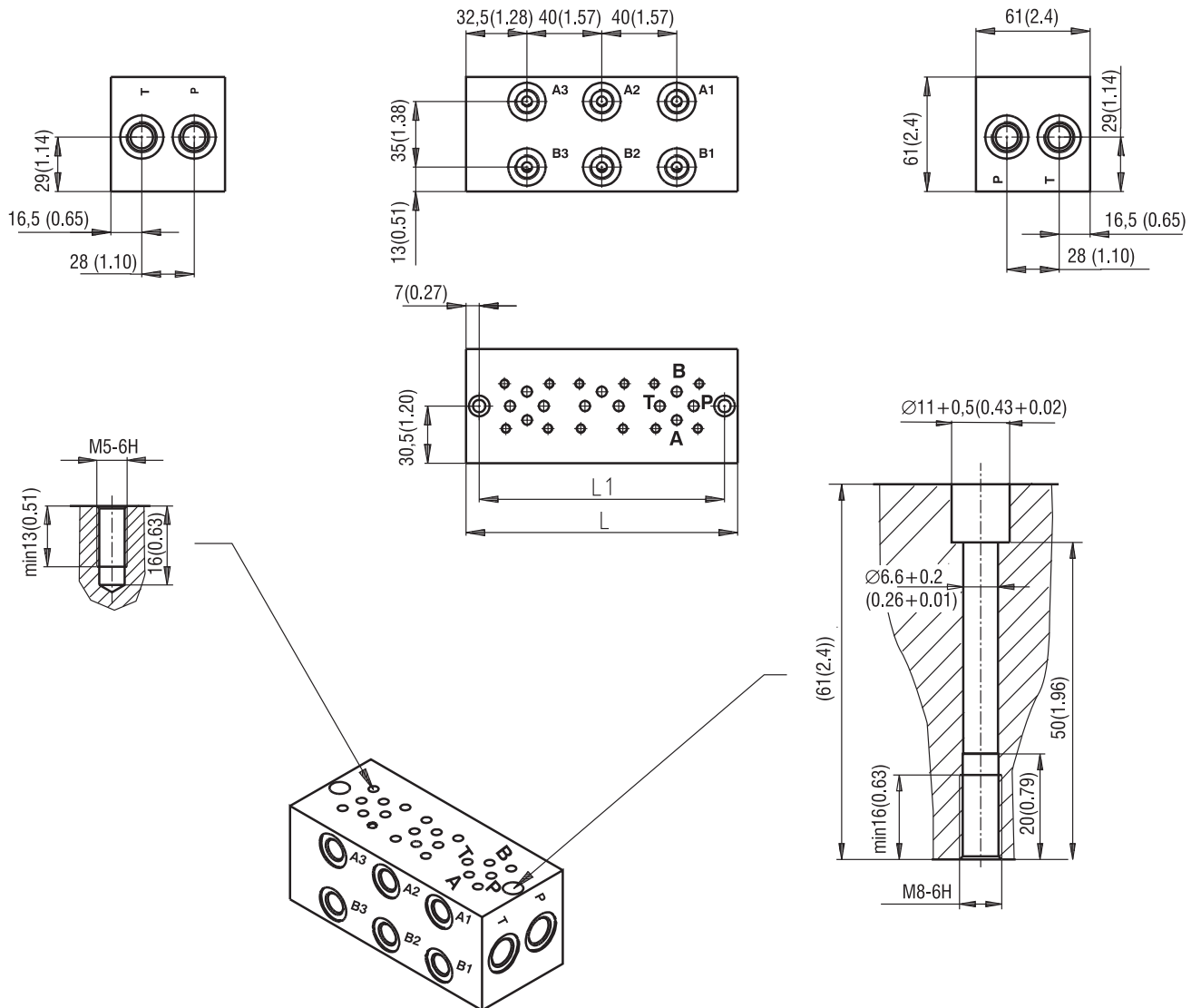

Section number	L [mm(in)]	L1 [mm(in)]	Ordering number
2	105(4.13)	91(3.58)	16112800
3	145(5.71)	131(6.74)	16112900
4	185(7.28)	171(6.73)	16113000
5	225(8.86)	211(8.31)	16113100
6	265(10.43)	251(9.88)	16113200
7	305(12.01)	291(11.46)	16113300
8	345(13.58)	331(13.03)	16113400

Valve Dimensions

Dimensions in millimeters (inches)

DR1 04 / □ 1

number of sections 1-8

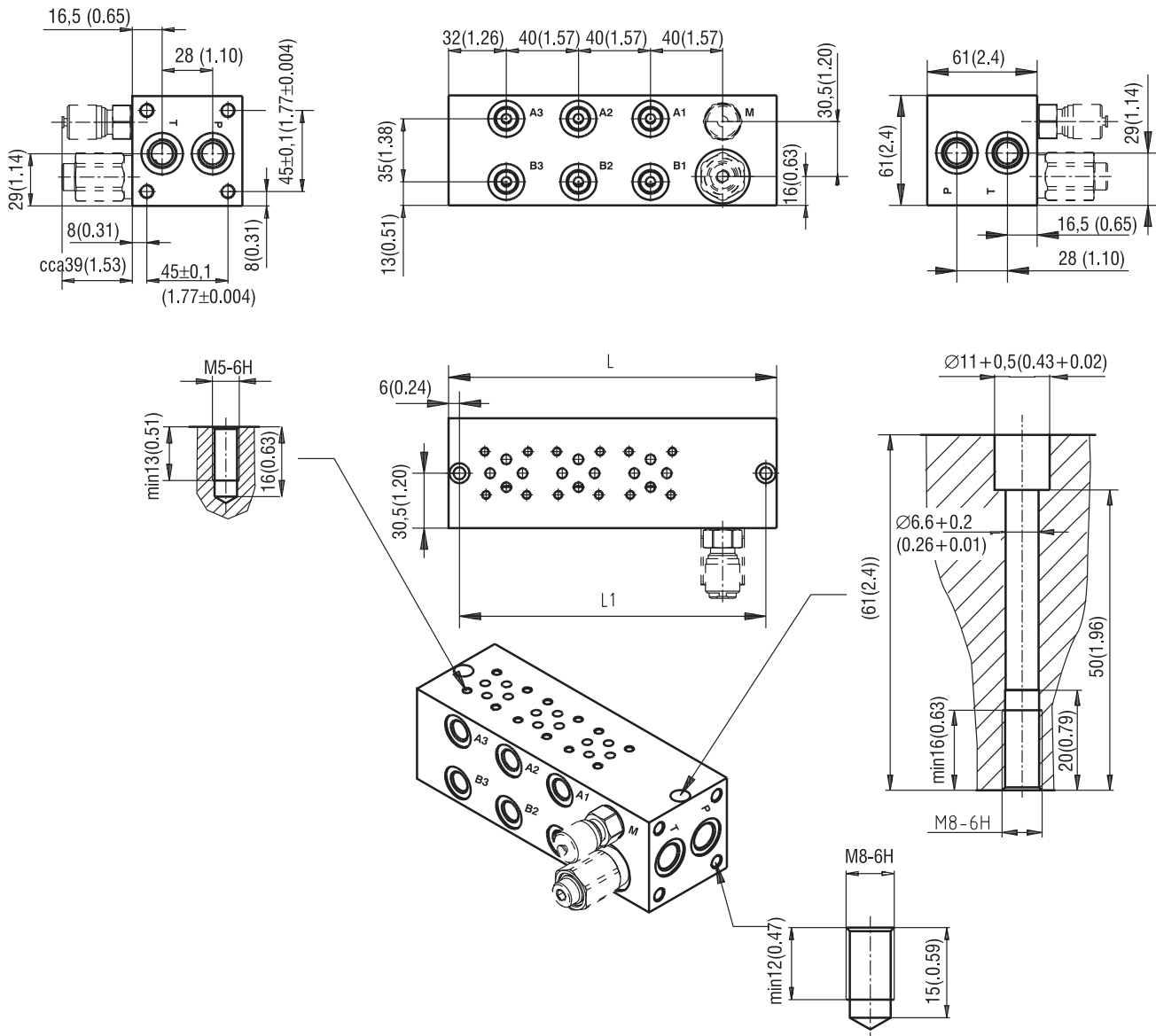

Section number	L [mm(in)]	L1 [mm(in)]	Ordering number
1	102(4.02)	90(3.54)	16113500
2	142(5.59)	130(5.12)	16113600
3	182(7.17)	170(6.69)	16113700
4	222(8.74)	210(8.27)	16113800
5	262(10.31)	250(9.84)	16113900
6	302(11.89)	290(11.42)	16114000
7	342(13.46)	330(12.99)	16114100
8	382(15.04)	370(14.57)	16114200

Valve Dimensions

Dimensions in millimeters (inches)

DR1 04 / 2

number of sections 1-8

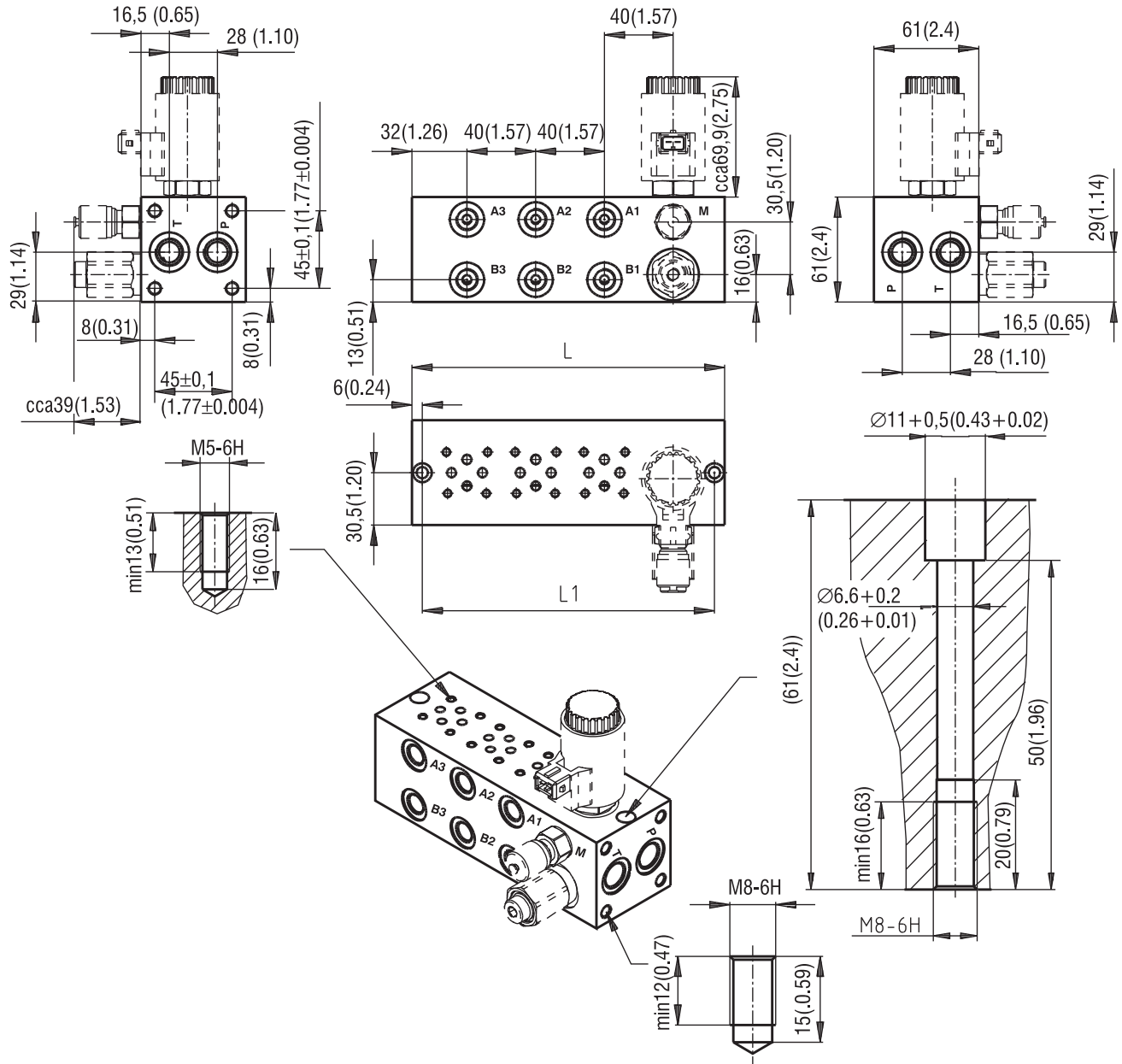

Section number	L [mm(in)]	L1 [mm(in)]	Ordering number
1	102(4.02)	90(3.54)	23693100
2	142(5.59)	130(5.12)	23693200
3	182(7.17)	170(6.69)	23693300
4	222(8.74)	210(8.27)	23693400
5	262(10.31)	250(9.84)	16772000
6	302(11.89)	290(11.42)	23693600
7	342(13.46)	330(12.99)	23693700
8	382(15.04)	370(14.57)	23693800

Caution!

- The packing foil is recyclable.
- The technical information regarding the product presented in this catalogue is for descriptive purposes only. It should not be construed in any case as a guaranteed representation of the product properties in the sense of the law.

ARGO-HYTOS s.r.o. CZ - 543 15 Vrchlabí
Tel.: +420-499-403111, Fax: +420-499-403421
E-mail: sales.cz@argo-hytos.com
www.argo-hytos.com

- For in-line mounting of hydraulic valves
- Parallel connection of ports P and T
- 1 ...8 sections possible
- Installation dimensions size 06 to ISO 4401 CETOP - RP 121H
- Valve cavity 7/8-14UNF

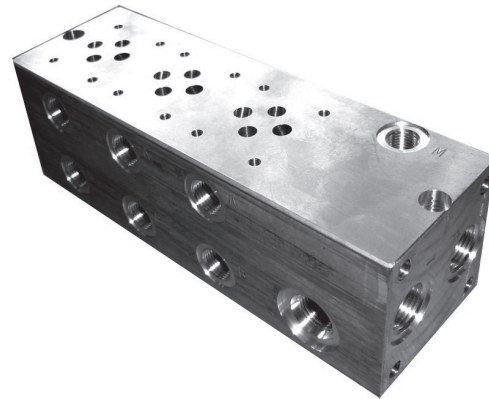

Ordering Code

DR2-06 /

In-line connecting plate 7/8-14UNF		AL ST	Material Aluminum Steel
Nominal size	0 1 2	without cavities with one cavity for pressure valve with two cavities for pressure relief and unloading valves	Number of sections 1 section 2 sections 3 sections 4 sections 5 sections 6 sections 7 sections 8 sections

Valve Dimensions

Dimensions in millimeters

DR2 06 / □ 0

number of sections 1-8

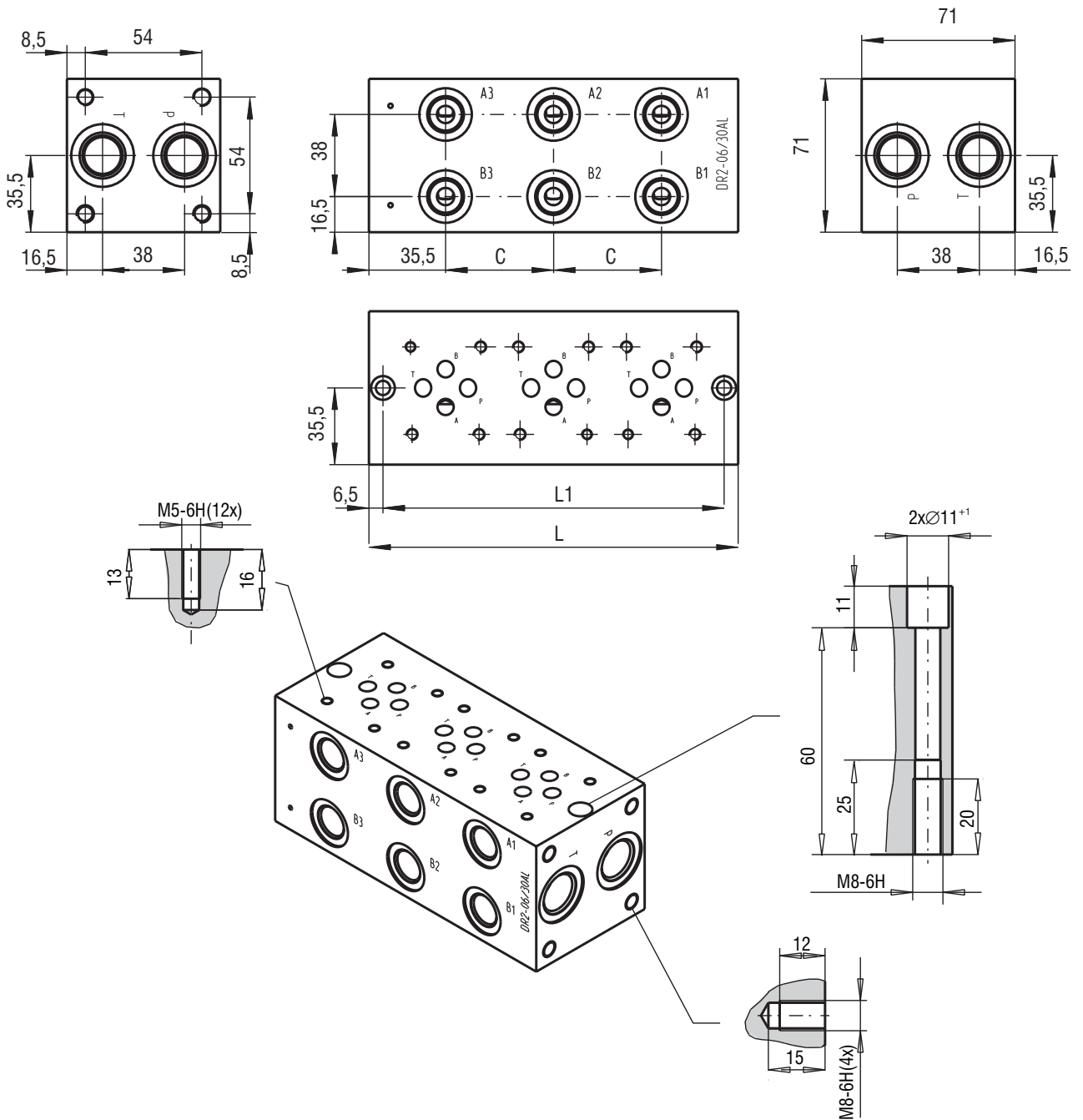

Number of sections	L (mm)	L1 (mm)	C (mm)	Ordering number	Weight (kg)	Ordering number	Weight (kg)
				AL		ST	
1	71	58	50	27562600	0,83	28262900	2,33
2	121	108	50	27562700	1,43	28263000	4,15
3	171	158	50	27562800	2,03	28263100	5,70
4	221	208	50	27562900	2,63	28263200	7,38
5	271	258	50	27563000	3,23	28263300	9,07
6	321	308	50	27563100	3,83	28263400	10,75
7	371	358	50	27563200	4,43	28263500	12,43
8	421	408	50	27563400	5,03	28263600	14,12

Valve Dimensions

Dimensions in millimeters

DR2 06 / 1

number of sections 1-8

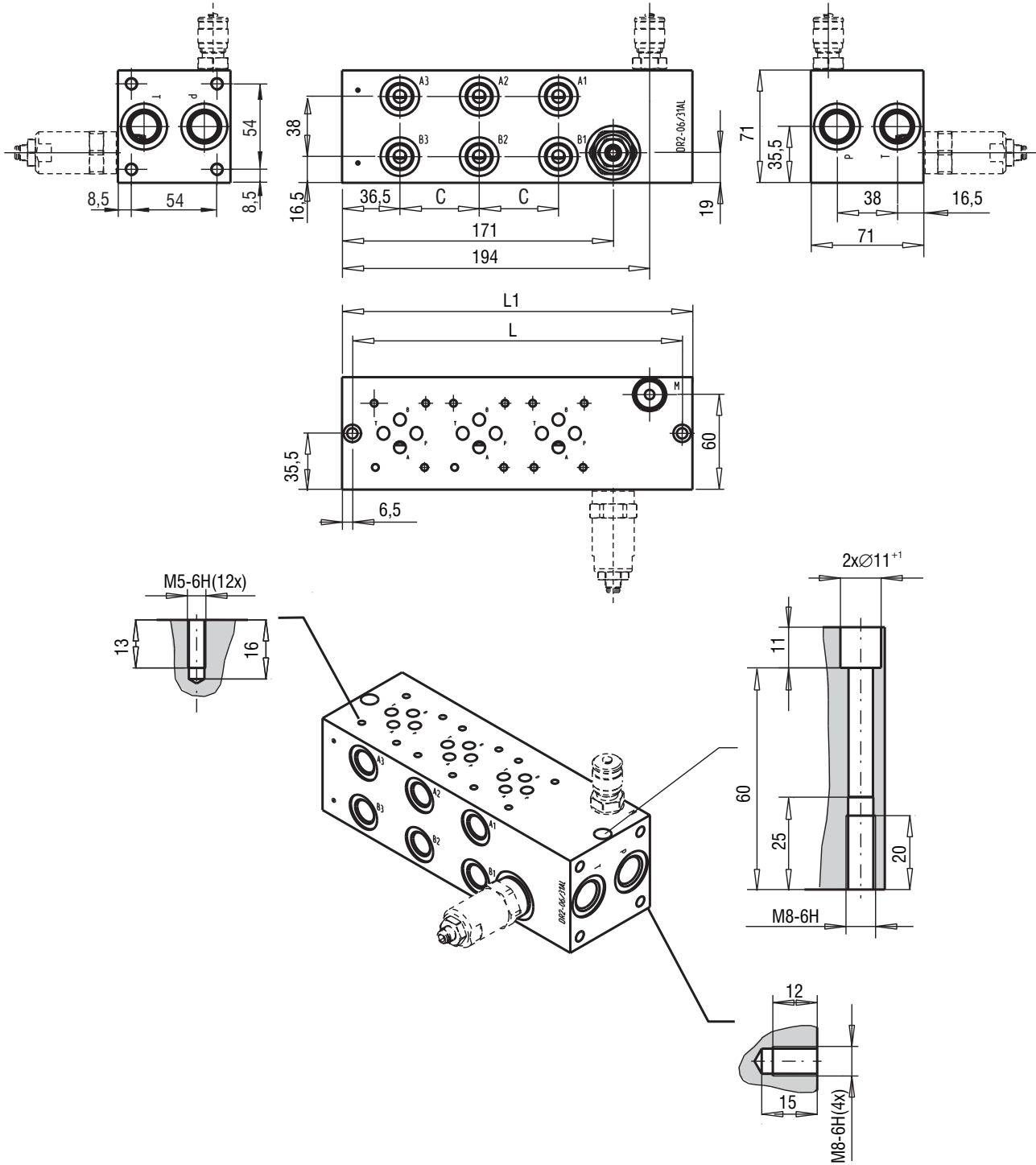

Number of sections	L (mm)	L1 (mm)	C (mm)	Ordering number	Weight (kg)	Ordering number	Weight (kg)
				AL		ST	
1	121	108	50	27563500	1,43	28263700	4,02
2	171	158	50	27563600	2,03	28263800	5,70
3	221	208	50	27563700	2,63	28263900	7,38
4	271	258	50	27563800	3,23	28264000	9,06
5	321	308	50	27563900	3,83	28264100	10,72
6	371	358	50	27564000	4,42	28264200	12,43
7	421	408	50	27564100	5,02	28264300	14,12
8	471	458	50	27564200	5,62	28264400	15,80

Valve Dimensions

Dimensions in millimeters

DR2 06 / □ 2

number of sections 1-8

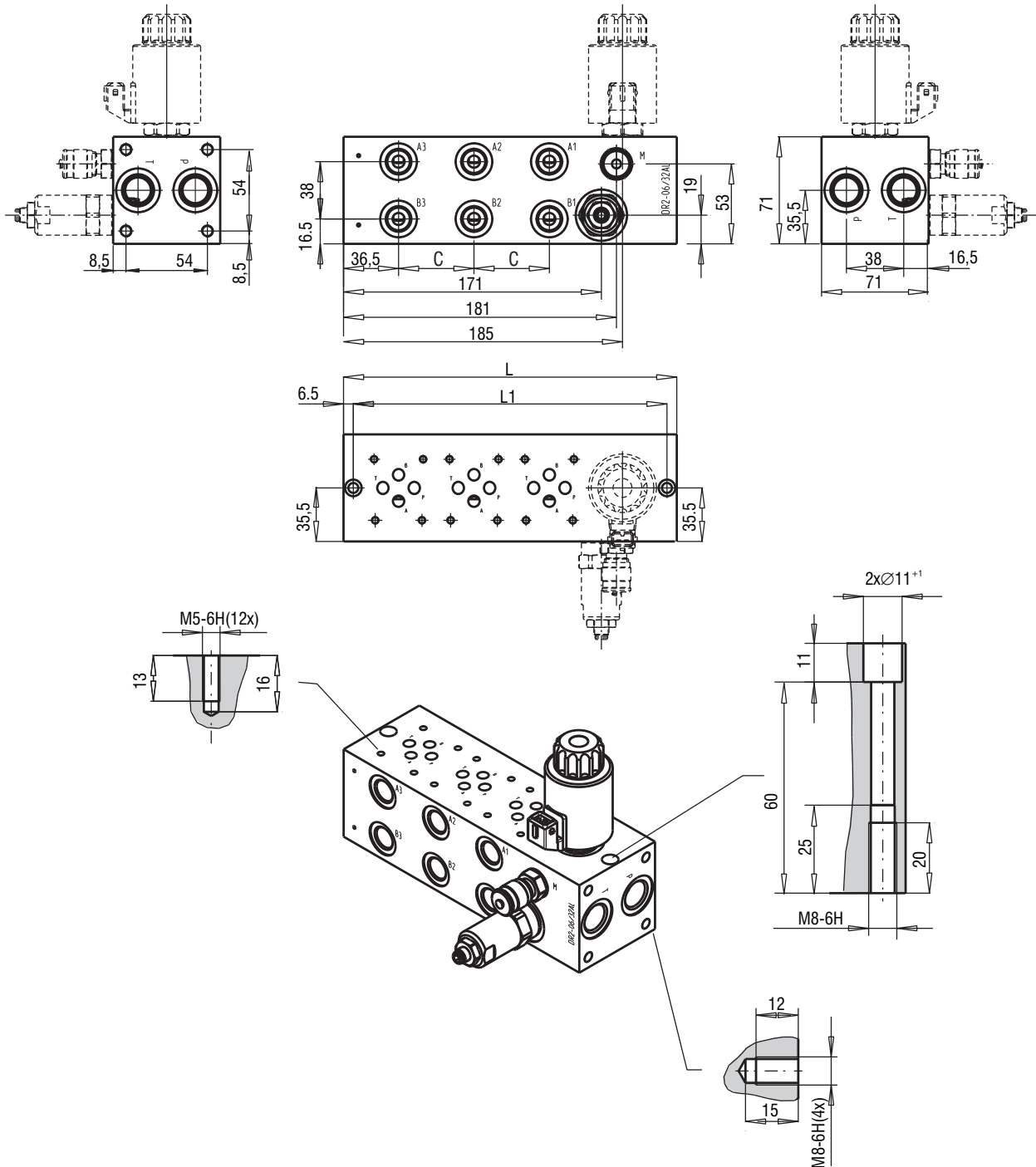

Number of sections	L (mm)	L1 (mm)	C (mm)	Ordering number	Weight (kg)	Ordering number	Weight (kg)
				AL		ST	
1	121	108	50	27632300	1,38	28269600	3,88
2	171	158	50	27632500	1,98	28269700	5,57
3	221	208	50	27632600	2,58	28269800	7,25
4	271	258	50	27632700	3,18	28269900	8,94
5	321	308	50	27632800	3,78	28270000	10,62
6	371	358	50	27632900	4,38	28270100	12,30
7	421	408	50	27633000	4,98	28270200	13,99
8	471	458	50	27633100	5,58	28270300	15,67

Caution!

- The packing foil is recyclable.
- The technical information regarding the product presented in this catalogue is for descriptive purposes only. It should not be construed in any case as a guaranteed representation of the product properties in the sense of the law.

ARGO-HYTOS s.r.o. CZ - 543 15 Vrchlabí
Tel.: +420-499-403111, Fax: +420-499-403421
E-mail: sales.cz@argo-hytos.com
www.argo-hytos.com

- For in-line mounting of hydraulic valves
- Parallel connection of ports P and T
- 1 ... 6 sections possible
- Installation dimensions size 10 to ISO 4401 and DIN 24 340-A10

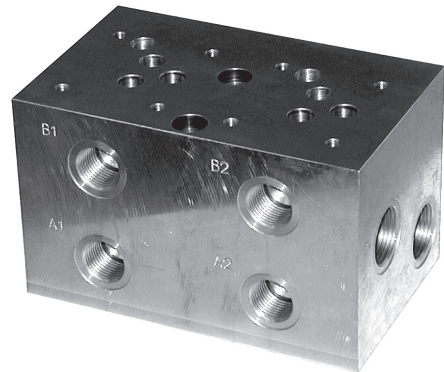

Ordering Code

PD10 - **AL**

In-line connecting plate

Nominal size

Connection
see functional symbol

A

Material - aluminium

Number of sections

1	1 section
2	2 sections
3	3 sections
4	4 sections
5	5 sections
6	6 sections

Functional Symbol

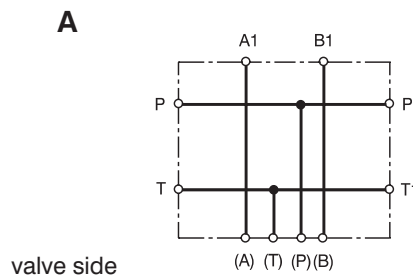

Survey of types

Type	Ordering number	Weight lbs (kg)
PD10A1-AL	16108400	5.10 (2.32)
PD10A2-AL	16108500	9.85 (4.48)
PD10A3-AL	16108600	14.55 (6.62)
PD10A4-AL	16108700	19.45 (8.85)
PD10A5-AL	16108800	24.24 (11.03)
PD10A6-AL	16108900	29.03 (13.21)

**FOR PREFERRED TYPES SEE BOLD TYPING IN ORDERING CODE
AND TABLE OF SURVEY OF TYPES**

Plate Dimensions

Dimensions in millimetres

Plates with 1 section

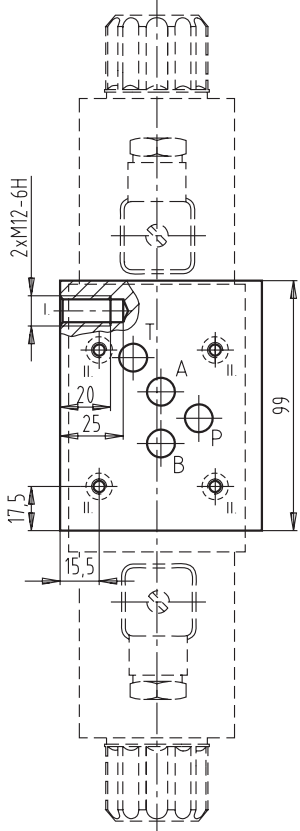
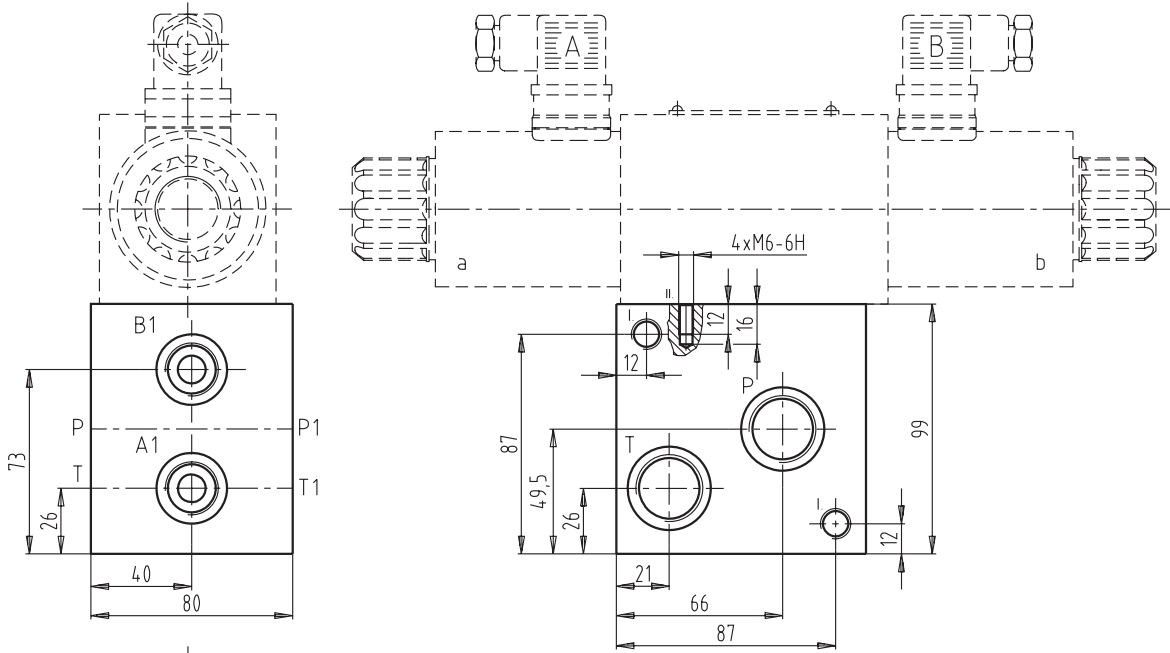

P, T, P1, T1

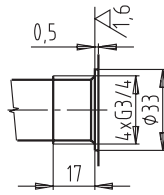

A, B

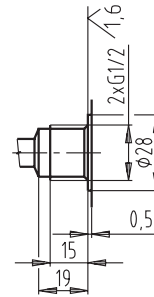

Installation dimensions

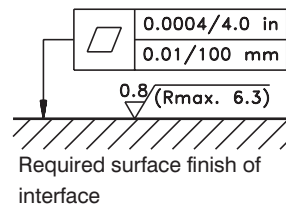
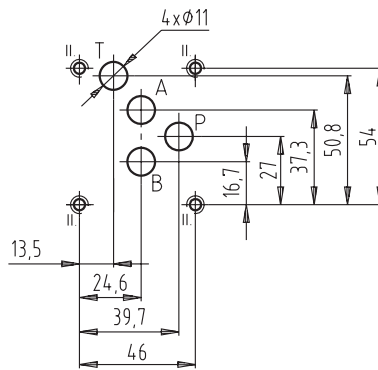

Port	A, B	P, T, P1, T1
Thread	G1/2	G3/4
Depth of thread	15	17
Counterbore	Ø28	Ø33
Depth of counterbore	0.5	0.5

Plate Dimensions

Dimensions in millimetres

Plates with 2 ... 6 sections

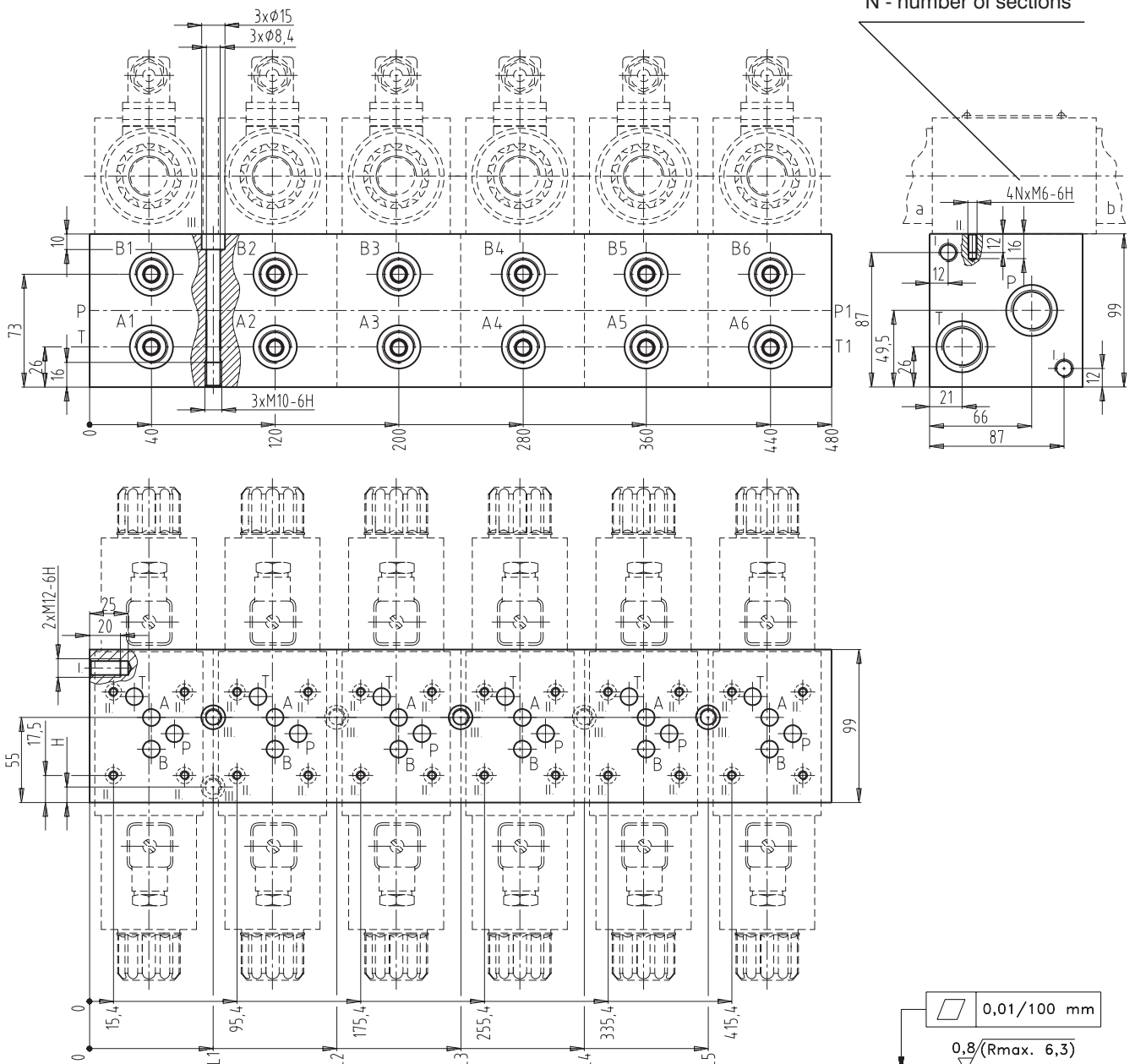

0,01/100 mm
0,8 (Rmax. 6,3)
Required surface finish of interface

Number of sections	L1	L2	L3	L4	L5	H
2	80	-	-	-	-	10
3	80	160	-	-	-	-
4	80	-	240	-	-	-
5	80	-	240	320	-	-
6	80	-	240	-	400	-
Port		A1...A6, B1...B6			P, T, P1, T1	
Thread		G1/2			G3/4	
Depth of thread		15			17	
Counterbore		Ø28			Ø33	
Depth of counterbore		0.5			0.5	

Caution!

- The packing foil is recyclable.
- The technical information regarding the product presented in this catalogue is for descriptive purposes only. It should not be construed in any case as a guaranteed representation of the product properties in the sense of the law.

ARGO-HYTOS s.r.o. CZ - 543 15 Vrchlabí
Tel.: +420-499-403111, Fax: +420-499-403421
E-mail: sales.cz@argo-hytos.com
www.argo-hytos.com

Functional Symbols

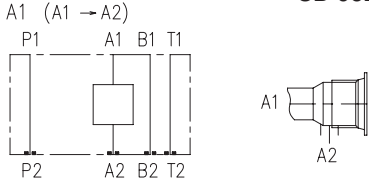
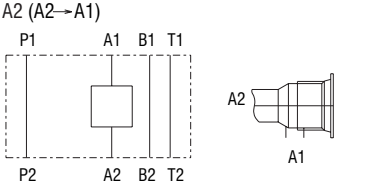
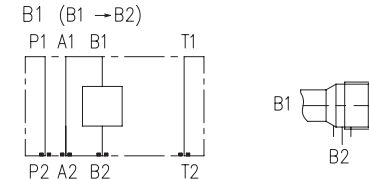
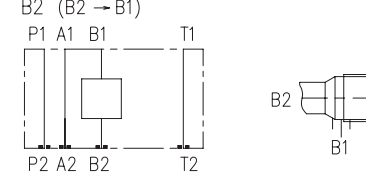
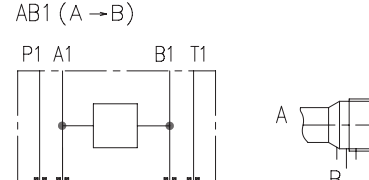
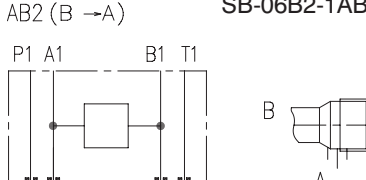
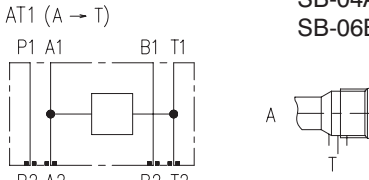
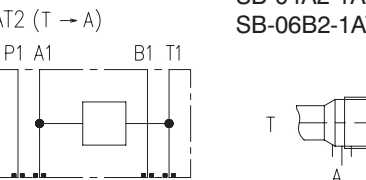
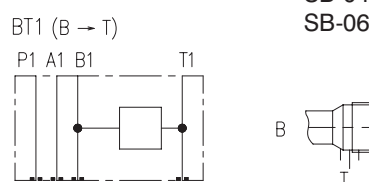
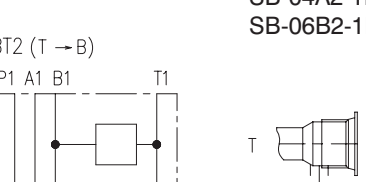
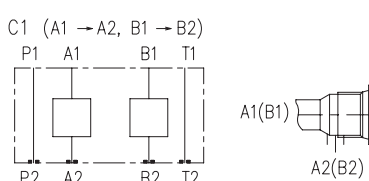
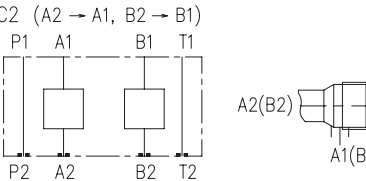
		Size	Cavity	Dimensions
		AxBxC/D[mm(in)]		
A1 (A1→A2) SB-04A2-1A1-*** SB-06B2-1A1-*** 	A2 (A2→A1) SB-04A2-1A2-*** SB-06B2-1A2-*** 	04	A2	36x40x74/37 (1.41x 1.57x2.91 /1.46)
		06	B2	45x50x86/30,5 (1.77x1.97x3.39 /1.2)
B1 (B1→B2) SB-04A2-1B1-*** SB-06B2-1B1-*** 	B2 (B2→B1) SB-04A2-1B2-*** SB-06B2-1B2-*** 	04	A2	36x40x74/18,5 (1.41x 1.57x2.91 /0.73)
		06	B2	45x50x86/12,5 (1.77x1.97x3.39 /0.49)
AB1 (A→B) SB-04A2-1AB1-*** SB-06B2-1AB1-*** 	AB2 (B→A) SB-04A2-1AB2-*** SB-06B2-1AB2-*** 	04	A2	36x40x74/31,5 (1.41x 1.57x2.91 /1.24)
		06	B2	45x50x86/30,5 (1.77x1.97x3.39 /1.2)
AT1 (A→T) SB-04A2-1AT1-*** SB-06B2-1AT1-*** 	AT2 (T→A) SB-04A2-1AT2-*** SB-06B2-1AT2-*** 	04	A2	36x40x74/31,5 (1.41x 1.57x2.91 /1.24)
		06	B2	45x50x86/30,5 (1.77x1.97x3.39 /1.2)
BT1 (B→T) SB-04A2-1BT1-*** SB-06B2-1BT1-*** 	BT2 (T→B) SB-04A2-1BT2-*** SB-06B2-1BT2-*** 	04	A2	36x40x74/18,5 (1.41x 1.57x2.91 /0.73)
		06	B2	45x50x86/12,5 (1.77x1.97x3.39 /0.49)
C1 (A1→A2, B1→B2) SB-04A2-2C1-*** SB-06B2-2C1-*** 	C2 (A2→A1, B2→B1) SB-04A2-2C2-*** SB-06B2-2C2-*** 	04	A2	36x40x98/37 (1.41x 1.57x 3.86 /1.45)
		06	B3	45x50x104/30,5 (1.77x1.97x 4.09 /1.2)

Functional Symbols

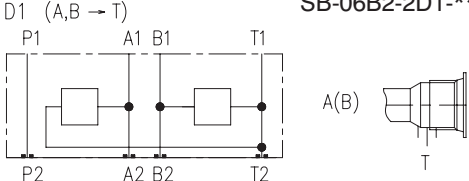
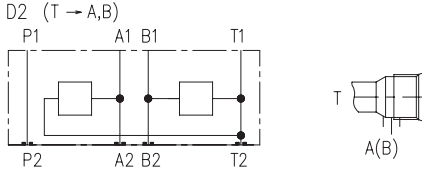
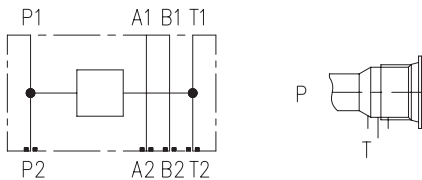
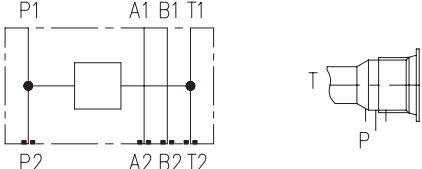
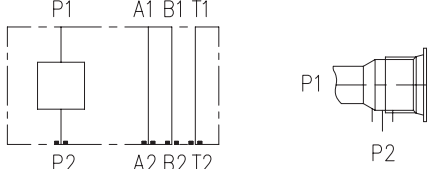
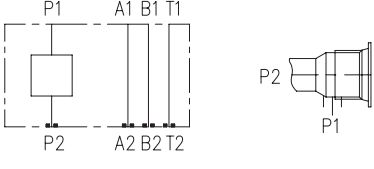
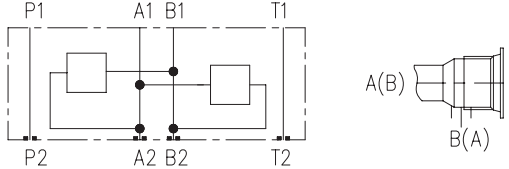
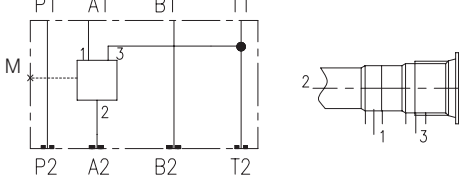
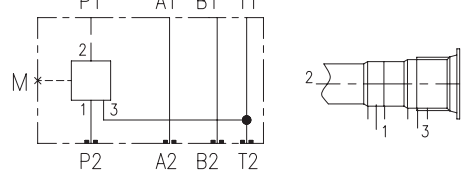
		Size	Cavity	Dimensions
		AxBxC/D[mm(in)]		
D1 (A,B → T) SB-04A2-2D1-*** SB-06B2-2D1-*** 	D2 (T → A,B) SB-04A2-2D2-*** SB-06B2-2D2-*** 	04	A2	36x40x98/37 (1.41x 1.57x 3.85 / 1.46)
		06	B2	45x50x86/30,5 (1.77x1.97x3.39 / 1.2)
PT1 (P → T) SB-04A2-1PT1-*** SB-06B2-1PT1-*** 	PT2 (T → P) SB-04A2-1PT2-*** SB-06B2-1PT2-*** 	04	A2	36x40x74/31,5 (1.41x 1.57x2.91 / 1.24)
		06	B2	45x50x86/30,5 (1.77x1.97x3.39 / 1.2)
P1 (P1 → P2) SB-04A2-1P1-*** SB-06B2-1P1-*** 	P2 (P2 → P1) SB-04A2-1P2-*** SB-06B2-1P2-*** 	04	A2	36x40x74/31,5 (1.41x 1.57x2.91 / 1.24)
		06	B2	45x50x86/30,5 (1.77x1.97x3.39 / 1.2)
C3 (B1 → A2, A1 → B2) SB-04A2-2C3-*** SB-06B2-2C3-*** 		04	A2	36x40x74/31,5 (1.41x 1.57x2.91 / 1.24)
		06	B2	45x50x104/30,5 (1.77x1.97x 4.09 / 1.2)
1A2 (A1 → A2, T) SB-06A3-1A2-*** SB-06B3-1A2-*** 		06	A3	45x50x73,5/42,5 (1.77x1.97x 2.89 / 1.67)
			B3	45x50x81/25,5 (1.77x1.97x 3.19 / 1.0)
1P2 (P2 → P1, T) SB-06A3-1P2-*** SB-06B3-1P2-*** 		06	A3	45x50x98/42,5 (1.77x1.97x 3.86 / 1.67)
			B3	45x50x98/42,5 (1.77x1.97x 3.86 / 1.67)

Sandwich Plates 04 a 06

Sandwich Plates 04 (D02) 3/4-16UNF

Sandwich Plates 06 (D03) 7/8-14UNF

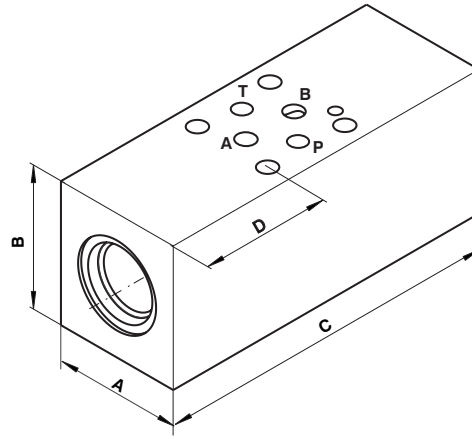

Installation Dimensions ISO 4401

Dimensions in millimeters and (inches)

ISO 4401-02-01-0-05

Size 04 (D02)

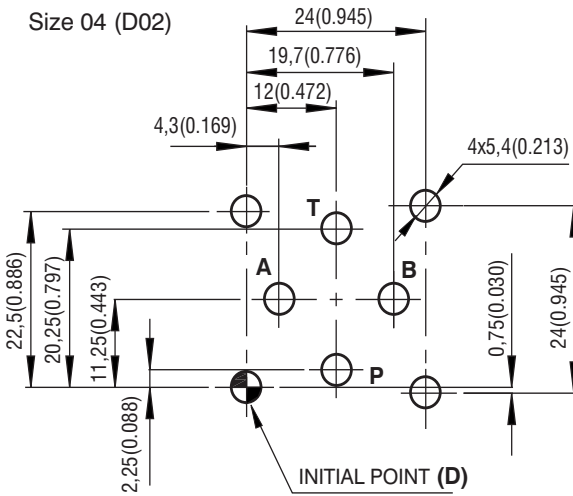

ISO 4401-03-03-0-05

Size 06 (D03)

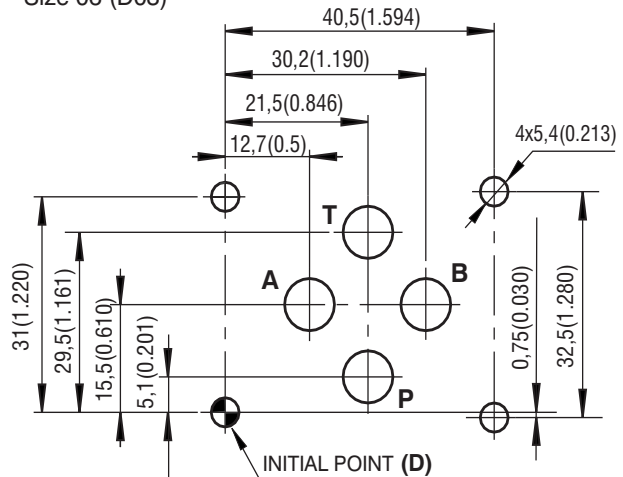

Spare Parts

Slize	Seal kit	Dimensinos, number	Ordering number
04 (D02)	Viton - O-ring	7,5 x 1,8 (4 pcs.)	29267300
06 (D03)	Viton - O-ring	9,25 x 1,78 (4 pcs.)	20152400

Caution!

- The packing foil is recyclable.
- Mounting bolts for mounting the subplates are not included.
- The technical information regarding the product presented in this catalogue is for descriptive purposes only. It should not be construed in any case as a guaranteed representation of the product properties in the sense of the law.

ARGO-HYTOS s.r.o. CZ - 543 15 Vrchlábí
 tel.: +420-499-403 111
 e-mail: info.cz@argo-hytos.com
 www.argo-hytos.com

- Pipeline housing for cartridge valves
- Installation dimensions to ISO 4401 and SAE
- Materials available are aluminum and steel

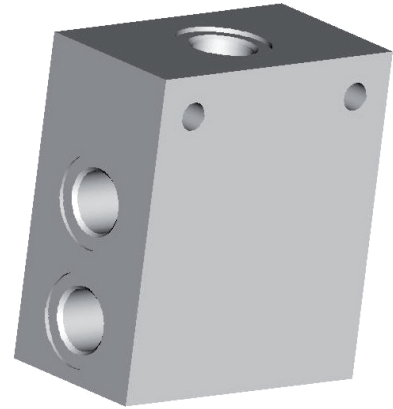

Ordering Code

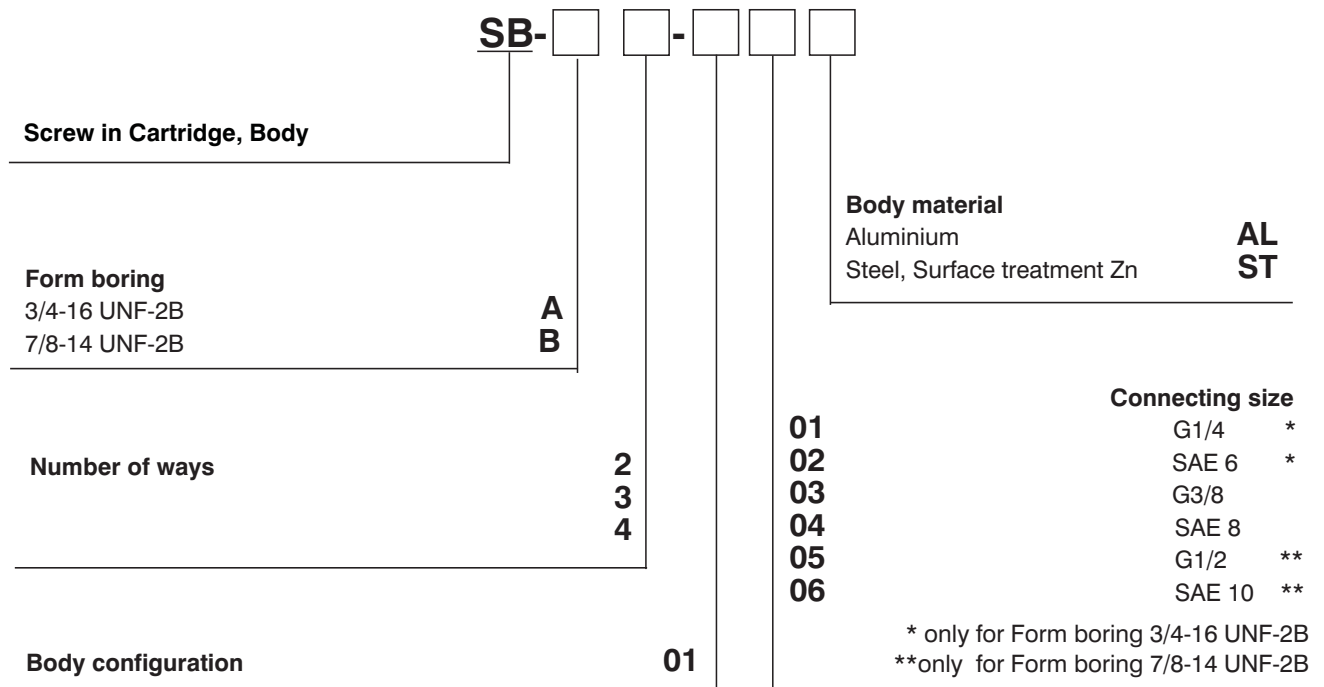

Form Boring - 3/4-16 UNF-2B

Dimensions in millimeters (inches)

Body for 2 Way SIC Valve

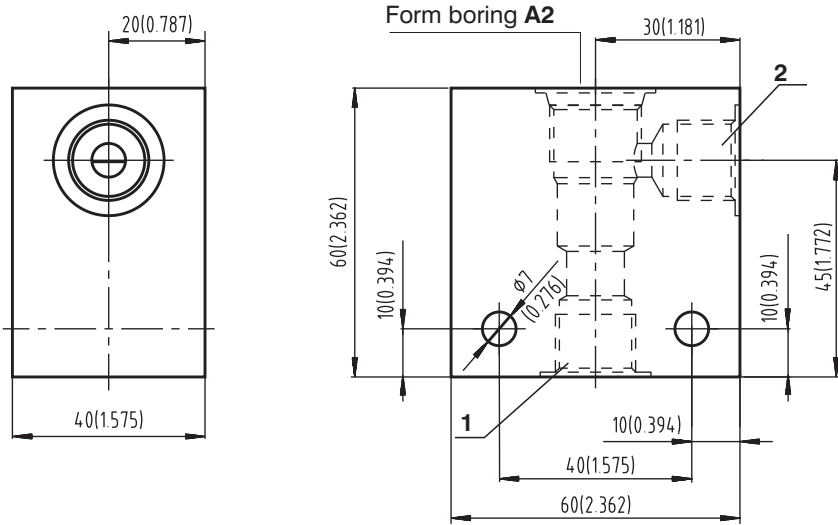

Connections	
1	2
G1/4, G3/8	
SAE 6, SAE 8	

Body material	Pressure	Weight
Aluminium	up to 250 bar (3626 PSI)	0,56 kg (1,23 lbs)
Steel	up to 420 bar (6091 PSI)	1,57 kg (3,46 lbs)

Body for 3 Way SIC Valve

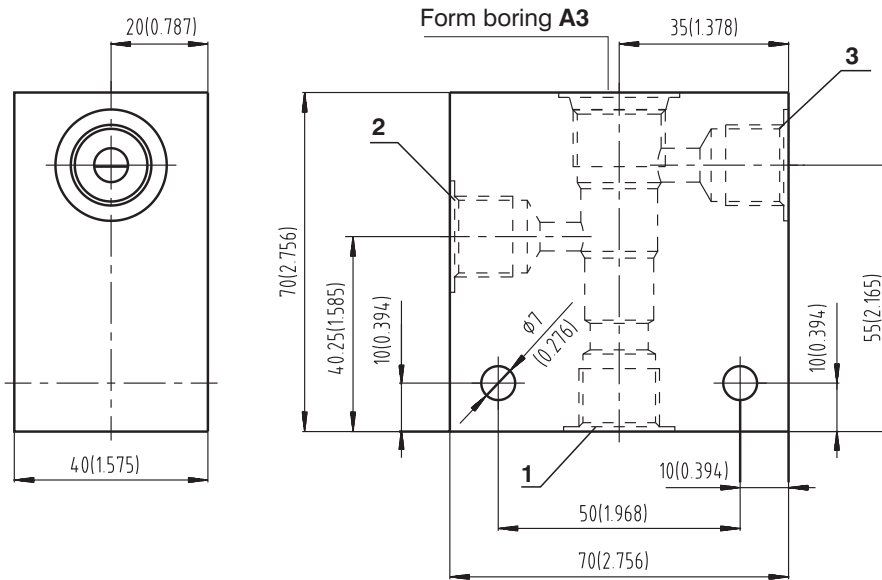

Connections		
1	2	3
G1/4, G3/8		
SAE 6, SAE 8		

Body material	Pressure	Weight
Aluminium	up to 250 bar (3626 PSI)	0,63 kg (1,39 lbs)
Steel	up to 420 bar (6091 PSI)	1,78 kg (3,92 lbs)

Body for 4 Way SIC Valve

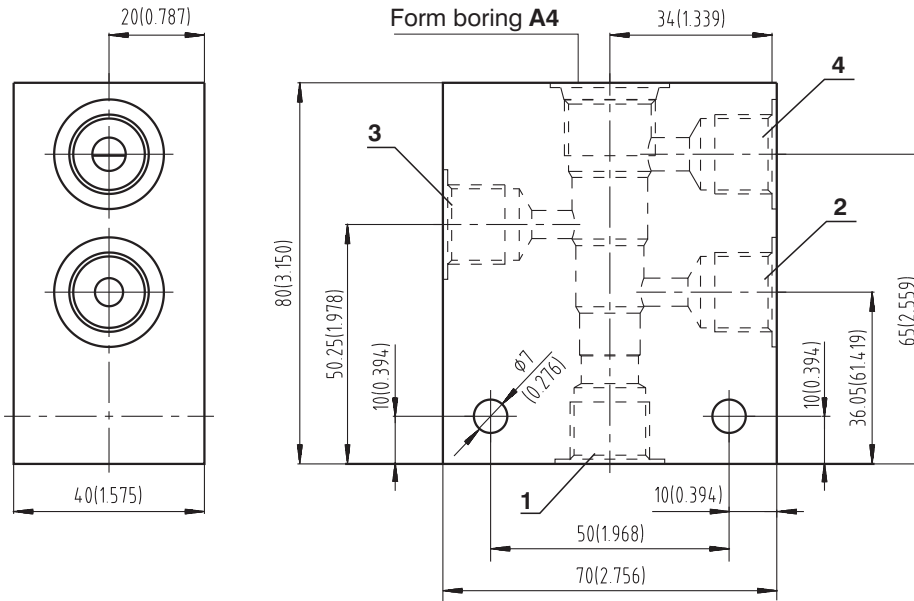

Connections			
1	2	3	4
G1/4, G3/8			
SAE 6, SAE 8			

Body material	Pressure	Weight
Aluminium	up to 250 bar (3626 PSI)	0,76 kg (1,68 lbs)
Steel	up to 420 bar (6091 PSI)	0,53 kg (4,72 lbs)

Form Boring - 7/8-14 UNF-2B

Body for 2 Way SIC Valve

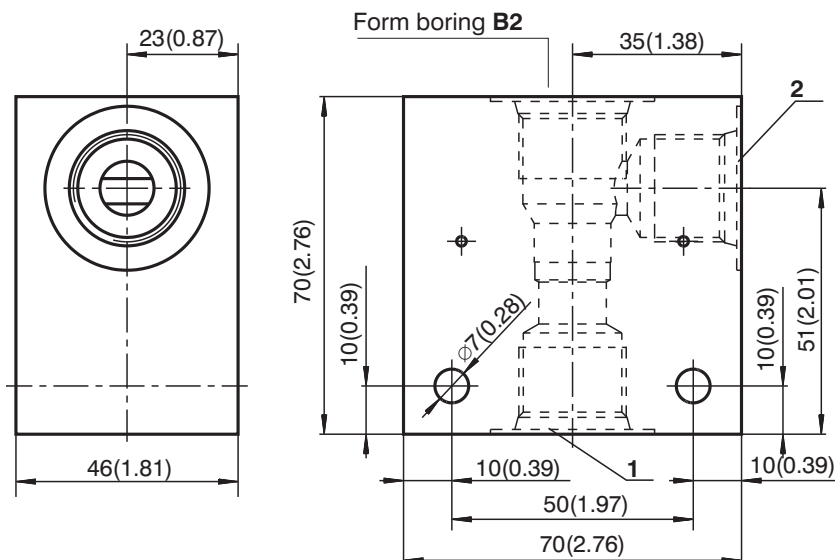

Connections	
1	2
G1/2, G3/8	
SAE 8, SAE 10	

Body material	Pressure	Weight
Aluminium	up to 250 bar (3626 PSI)	0,54 kg (1,19 lbs)
Steel	up to 420 bar (6091 PSI)	1,50 kg (3.31 lbs)

8

Body for 3 Way SIC Valve

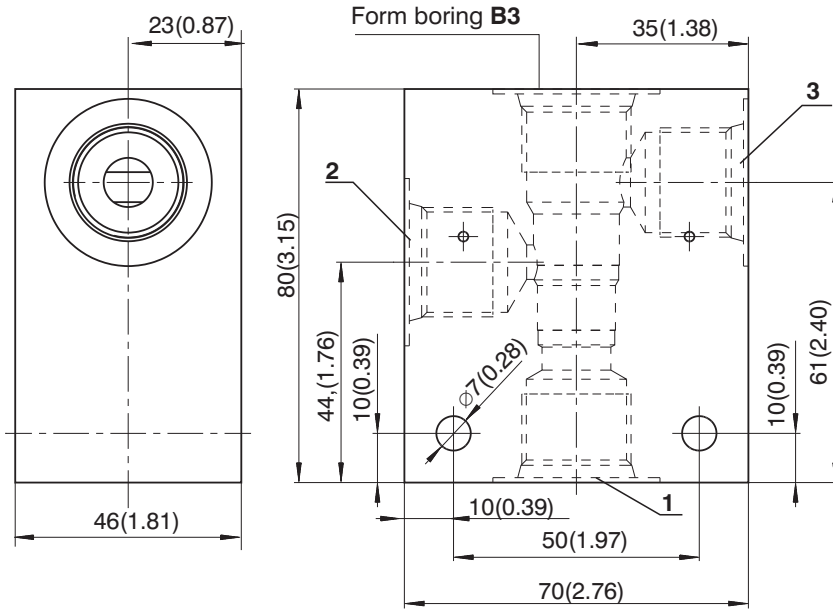

Connections		
1	2	3
G1/2, G3/8		
SAE 8, SAE 10		

Body material	Pressure	Weight
Aluminium	up to 250 bar (3626 PSI)	0,60 kg (1,32 lbs)
Steel	up to 420 bar (6091 PSI)	1,68 kg (3,70 lbs)

Body for 4 Way SIC Valve

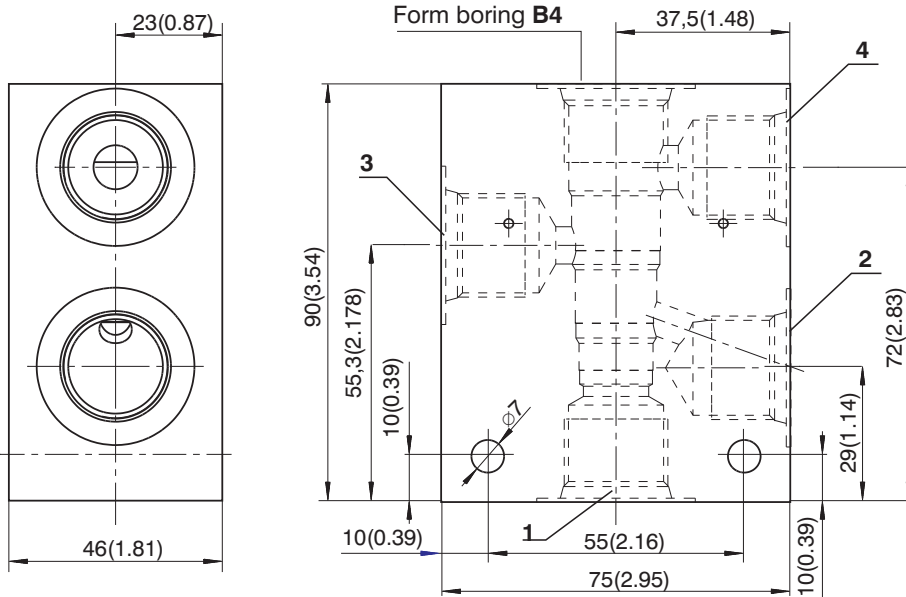

Connections			
1	2	3	4
G1/2, G3/8			
SAE 8, SAE 10			

Body material	Pressure	Weight
Aluminium	up to 250 bar (3626 PSI)	0,71kg (1.57 lbs)
Steel	up to 420 bar (6091 PSI)	1,99 kg (4.39 lbs)

Caution!

- Recommended fixing bolts M6 x 55 DIN 912-10.9, bolt tightening torque 14+2 Nm (10.33+1.48 lbf.ft)
- The packing foil is recyclable.
- The technical information regarding the product presented in this catalogue is for descriptive purposes only. It should not be construed in any case as a guaranteed representation of the product properties in the sense of the law.

ARGO-HYTOS s.r.o. CZ - 543 15 Vrchlabí
 Tel.: +420-499-403111, Fax: +420-499-403421
 E-mail: sales.cz@argo-hytos.com
 www.argo-hytos.com

- Subplates for individual mounting of hydraulic components in hydraulic circuits with connections realized by tubes or hoses
- Universal subplates for connection of any components with installation dimensions to ISO 4401: 1994, DIN 24 340 and CETOP
 Installation dimensions of size 04: ISO 4401-02-01-0-94 and CETOP - RP 121H
 Installation dimensions of size 06: ISO 4401-03-02-0-94 and DIN 24 340-A6
 Installation dimensions of size 10: ISO 4401-05-04-0-94 and DIN 24 340-A10
- Special subplates - see the Survey of Applications
- The valve housing surface is phosphate coated

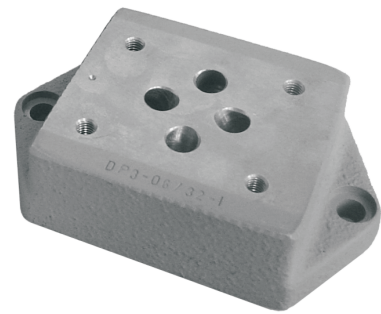

Survey of Applications

Subplate	For hydraulic valve (catalogue No.)
Size 04	
DP4-04/32-3 DP4-04/32-4 DP3-04/32-10	RPE3-04 (HA 4014) VSO1-04/M (HA 5053) VJR1-04/M (HA 5023) VJO1-04/M (HA 5012) VRP2-04 (HA 5142) VPP2-04 (HA 5093)
Size 06	
DP2-06/32-1 DP2-06/32-2 DP3-06/32-1 DP3-06/32-2 DP3-06/32-3 DP3-06/32-4 DP3-06/32-5 DP3-06/32-7 DP3-06/32-8 DP3-06/32-9 DP3-06/32-11 DP3-06/32-12 DP3-06/32-13 DP3-06/32-15 DP3-06/32-16 DP3-06/32-17	RPR3-06 (HA 4004) RPH2-06 (HA 4005) RPE3-06 (HA 4010) VSS1-206 (HA 5032) VSS1-306 (HA 5033) VSS2-206 (HA 5041) 2VS3-06 (HA 5051) 2RJV1-06 (HA 5021) MVJ3-06 (HA 5018) VPP2-04 (HA 5093)

Subplate	For hydraulic valve (catalogue No.)
Size 10	
DP1-10/32-1 DP1-10/32-2	RPE3-10 (HA 4015) VSO2-10/M (HA 5056) VJR2-10/M (HA 5025) MVJ3-10 (HA 5020)
Special subplates	
D-06M/VPP1 D-06G/VPP1 D-08M/VPP1 D-08G/VPP1 D-10M/VPP1 D-10G/VPP1 DP3-TS2-1 DP3-TS2-3	VPP1 (HA 5061) VPP2 (HA 5062) TS2 (HA 9201) TS2 (HA 9201)

FOR PREFERRED TYPES SEE BOLD TYPING IN SURVEY OF APPLICATIONS

Subplates Size 04

Dimensions in millimetres

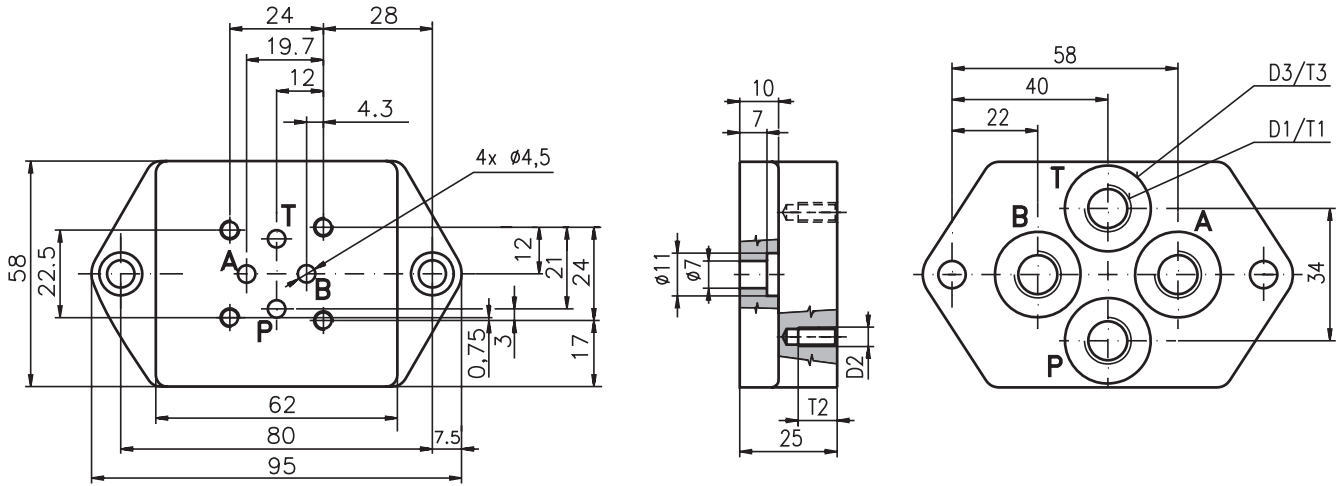

Ordering code	D1	T1	D2	T2	D3	T3	Weight kg
DP4-04/32-3	M12x1.5	13	M5	10	Ø22	1	0,6
DP4-04/32-4	BSPP 1/4						

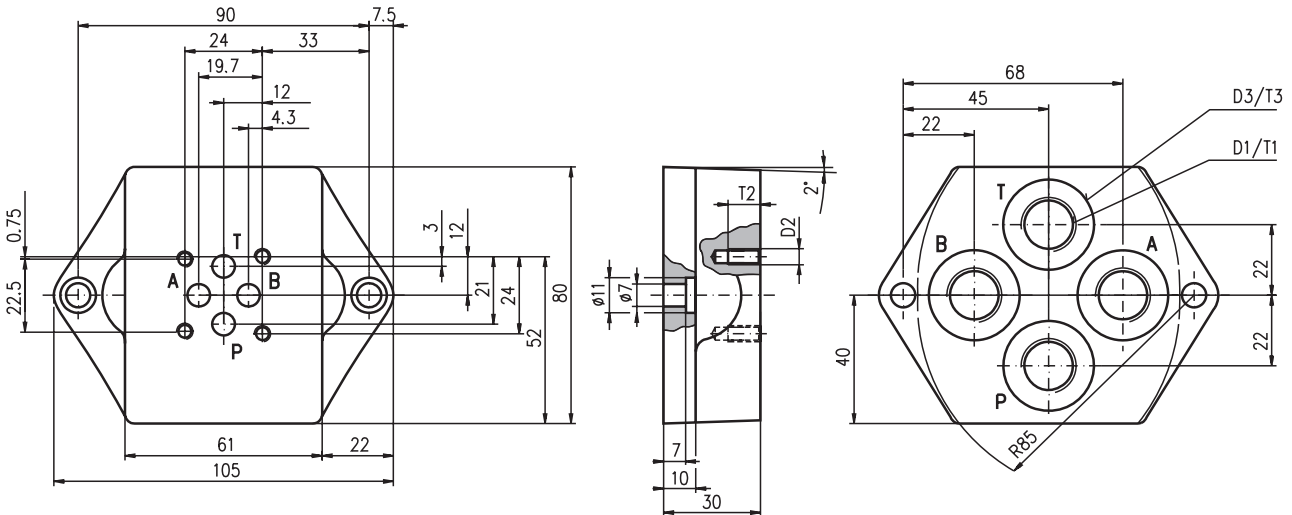

Ordering code	D1	T1	D2	T2	D3	T3	Weight kg
DP3-04/32-10	BSPP 3/8	12	M5	10	Ø28	1	0.9

Subplates Size 06

Dimensions in millimetres

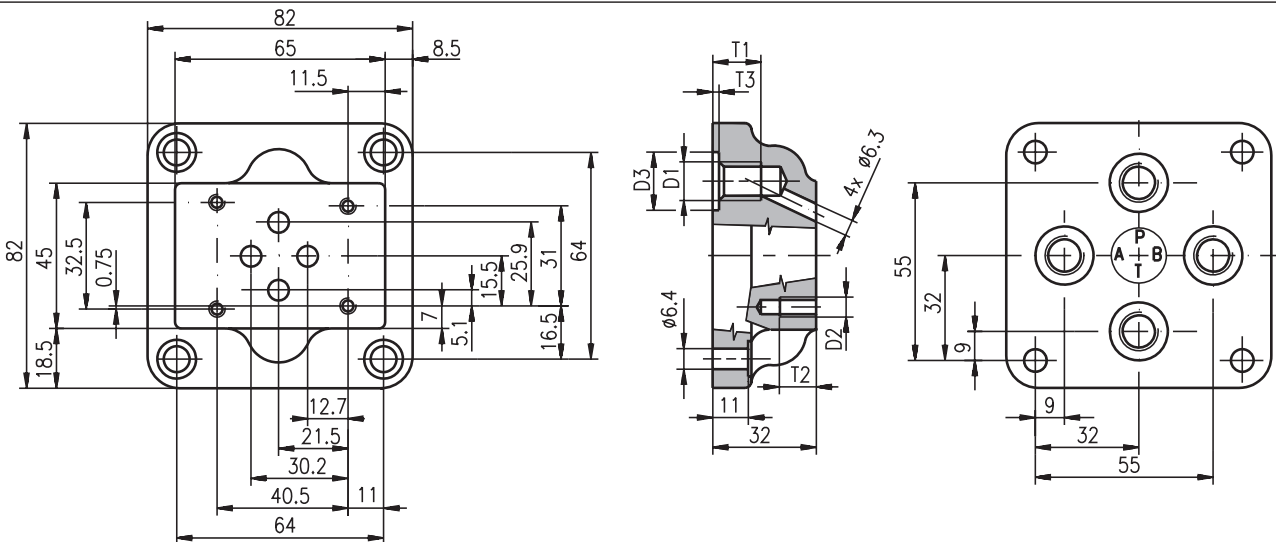

Ordering code	D1	T1	D2	T2	D3	T3	Weight kg
DP2-06/32-1	M12x1.5	15	M5	11	Ø18	2	0.95

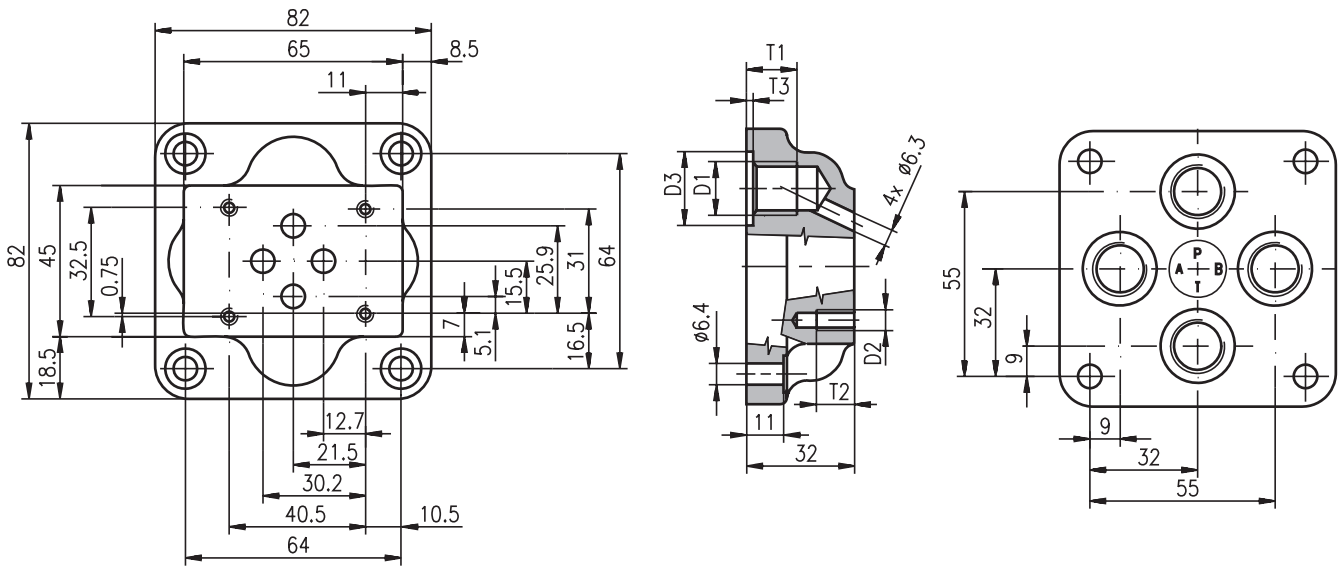

Orderig code	D1	T1	D2	T2	D3	T3	Weight kg
DP2-06/32-2	M16x1.5	17	M5	11	∅22	2	0.95

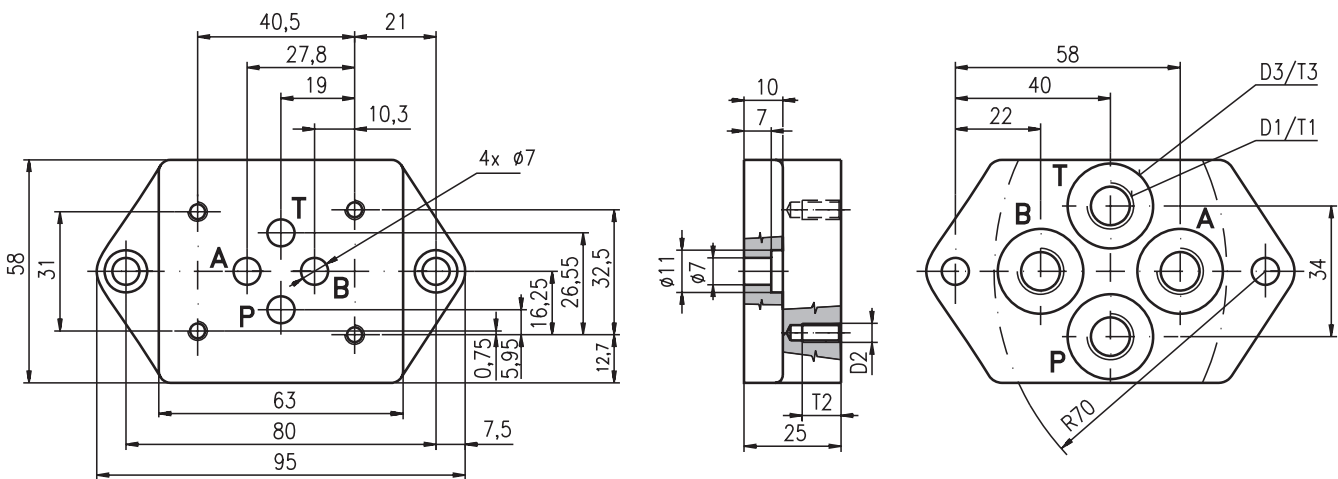

Ordering code	D1	T1	D2	T2	D3	T3	Weight kg
DP3-06/32-1	M12x1.5	13	M5	10	∅22	1	0.6
DP3-06/32-2	M14x1.5						
DP3-06/32-7	BSPP 1/4	10	10-24 UNC		-	-	
DP3-06/32-15	NPT 1/4						
DP3-06/32-11	SAE-6; 9/16-18	13			∅21	0.8	

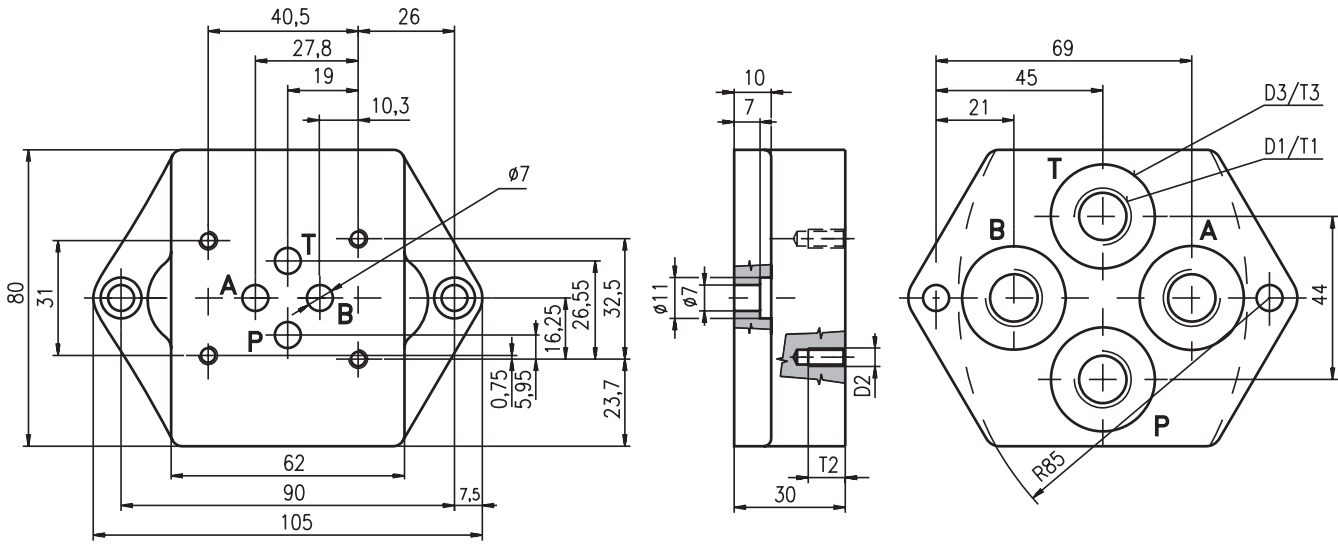

Ordering code	D1	T1	D2	T2	D3	T3	Weight kg
DP3-06/32-3	M16x1.5	0.512 (13)	M5	10	∅28)	1	1.1
DP3-06/32-4	M18x1.5						
DP3-06/32-8	BSPP 3/8						
DP3-06/32-16	NPT 3/8	10.3	10-24 UNC	-	-	-	-
DP3-06/32-12	SAE-8; 3/4-16	15		∅25	0.8	-	-

8

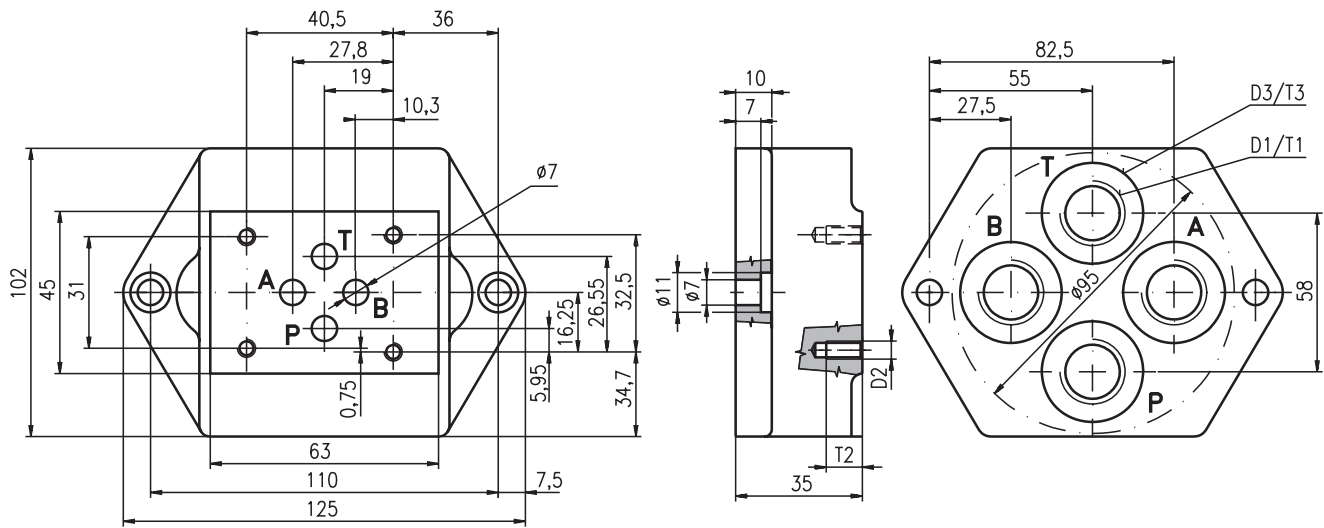

Ordering code	D1	T1	D2	T2	D3	T3	Weight kg
DP3-06/32-5	M22x1.5	14	M5	10	∅34	1	1.9
DP3-06/32-9	BSPP 1/2						
DP3-06/32-17	NPT 1/2						
DP3-06/32-13	SAE-8; 3/4-16	15	10-24 UNC	-	-	0.8	-

Subplates Size 10

Dimensions in millimetres

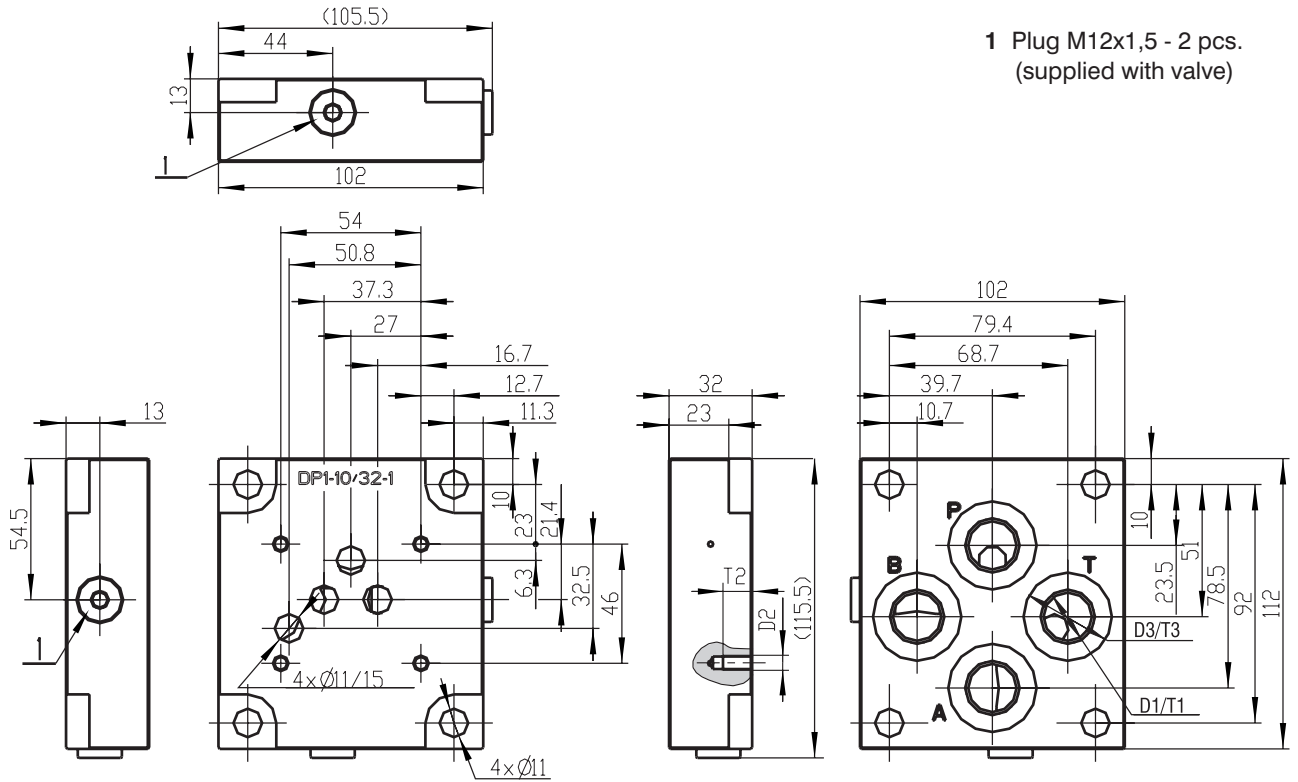

1 Plug M12x1,5 - 2 pcs.
(supplied with valve)

Ordering code	D1	T1	D2	T2	D3	T3	Weight kg
DP1-10/32-1	BSPP 1/2	14	M6	12	∅34	1	2.3

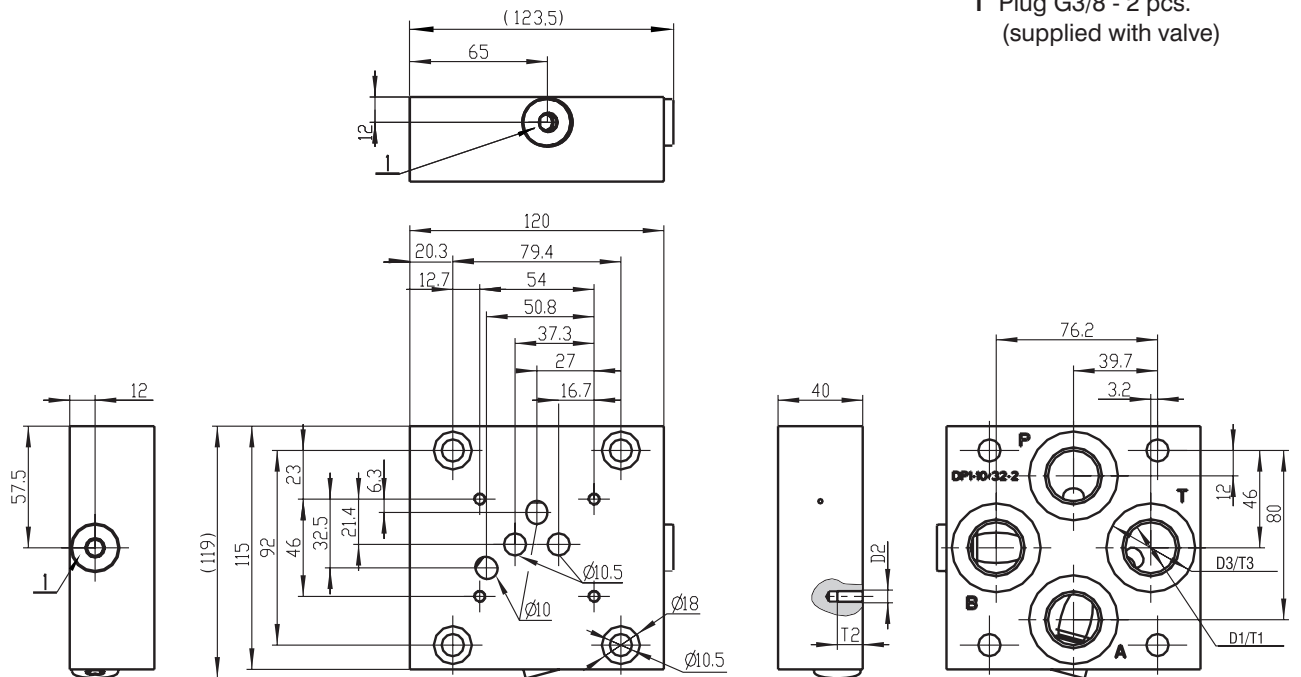

1 Plug G3/8 - 2 pcs.
(supplied with valve)

Ordering code	D1	T1	D2	T2	D3	T3	Weight kg
DP1-10/32-2	BSPP 3/4	16	M6	12	∅42	1	2.5

Special Subplates

Dimensions in millimetres

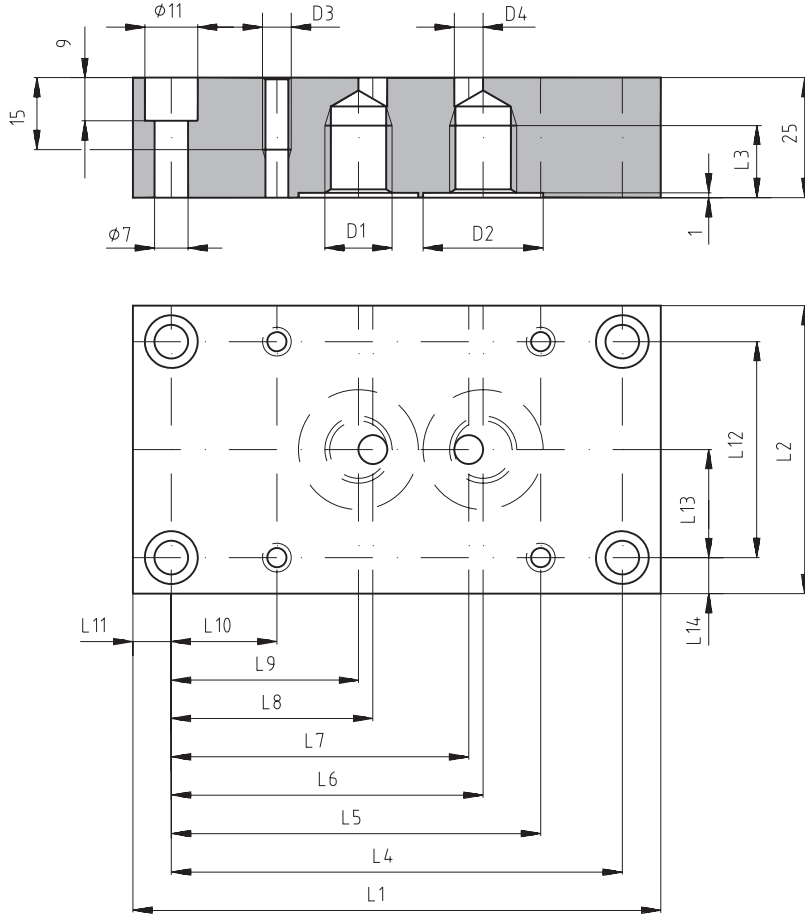

Ordering code	D1	ØD2	D3	ØD4	L1	L2	L3	L4	L5
D-06M/VPP1	M14x1.5	25	M6	6	110	60	15	94	77
D-06G/VPP1	BSPP 1/4								
D-08M/VPP1	M18x1.5	28	M8	10	135	80	16	115	97.5
D-08G/VPP1	BSPP 3/8								
D-10M/VPP1	M22x1.5	34)							
D-10G/VPP1	BSPP 1/2								
Ordering code	L6	L7	L8	L9	L10	L11	L12	L13	L14
D-06M/VPP1	65	62	42	39	22	8	45	225	7.5)
D-06G/VPP1									
D-08M/VPP1	80.5	72.5	48.5	40.5	27.5	10	60	30	10
D-08G/VPP1									
D-10M/VPP1									
D-10G/VPP1									

Weight of the subplate size 06 is 1.5 kg, weight of the subplates size 08 and 10 is 2.0 kg.

Caution!

- The packing foil is recyclable.
- The transport plate is to be returned to the supplier.
- Mounting bolts for fixing the subplates are not included.
- The technical information regarding the product presented in this catalogue is for descriptive purposes only. It should not be construed in any case as a guaranteed representation of the product properties in the sense of the law.

ARGO-HYTOS s.r.o. CZ - 543 15 Vrchlabí
 Tel.: +420-499-403111, Fax: +420-499-403421
 E-mail: sales.cz@argo-hytos.com
 www.argo-hytos.com

- Blanking plates - used mainly for covering the upper surface of the elements of the sandwich plate design when they are used separately
- The valve housing surface is phosphate coated

Blanking Plate DK1-04/32-1 Dimensions in mm

Used as universal blanking plate size 04.
Connects ports A and B.

Sealing rings	Weight of the plate	Ordering number of the plate
4 pcs. Square rings 7.65 x 1.68	0.10 kg	15916100

Sealing rings are delivered with each plate
(quantity and dimensions see the table above).

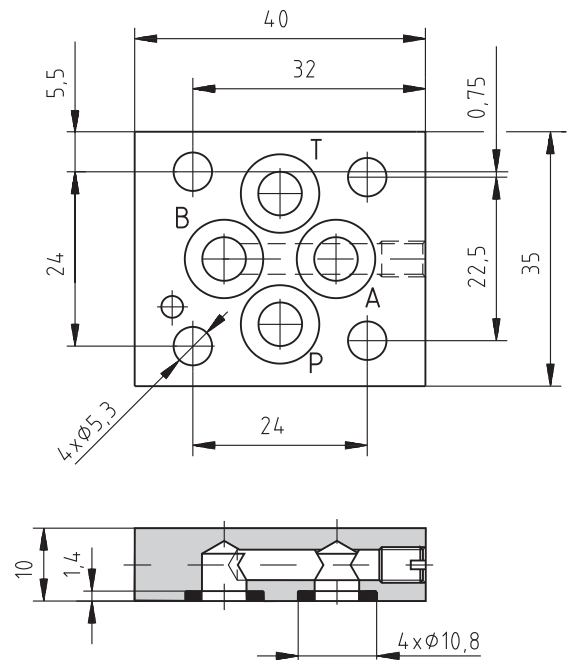

Blanking Plate DK1-04/32-2 Dimensions in mm

Used as universal blanking plate size 04.

Sealing rings	Weight of the plate	Ordering number of the plate
4 pcs. Square rings 7.65 x 1.68	0.10 kg	15915900

Sealing rings are delivered with each plate
(quantity and dimensions see the table above).

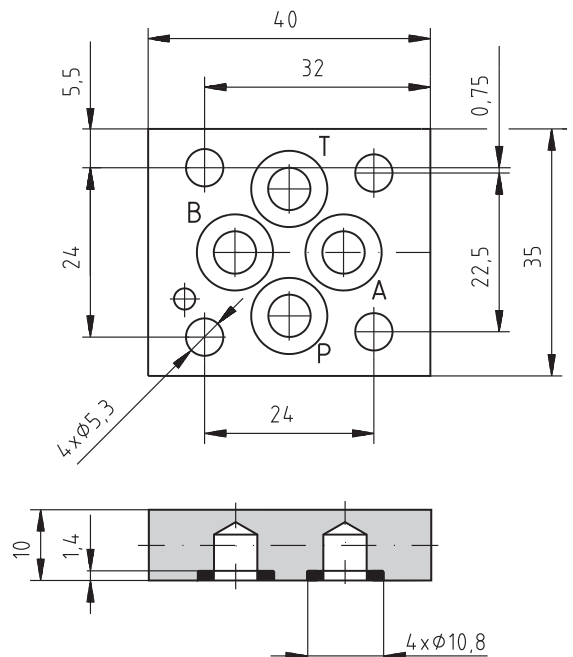

Blanking Plate DK1-04/32-3

Dimensions in mm

Used as universal blanking plate size 04.
Connects ports A and P.

Sealing rings	Weight of the plate	Ordering number of the plate
4 pcs. Square rings 7.65 x 1.68	0.10 kg	15915700

Sealing rings are delivered with each plate
(quantity and dimensions see the table above).

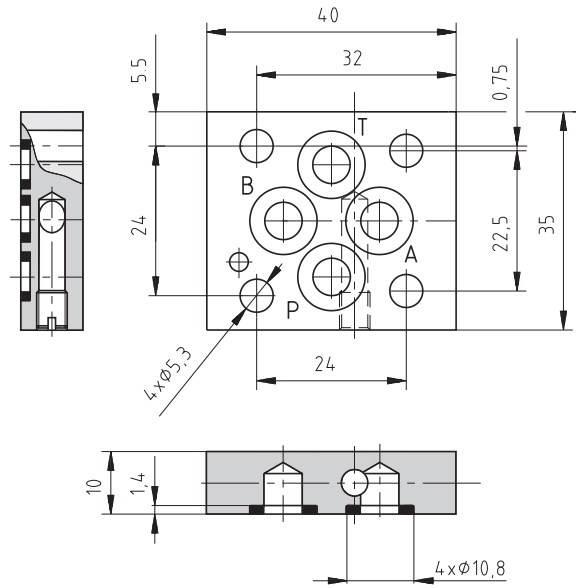

Blanking Plate DK1-06/32-1

Dimensions in mm

Used as universal blanking plate size 06.
Connects ports A and B

Sealing rings	Weight of the plate	Ordering number of the plate
4 pcs. Square rings 9.25 x 1.68	0.32 kg	15933800

Sealing rings are delivered with each plate
(quantity and dimensions see the table above).

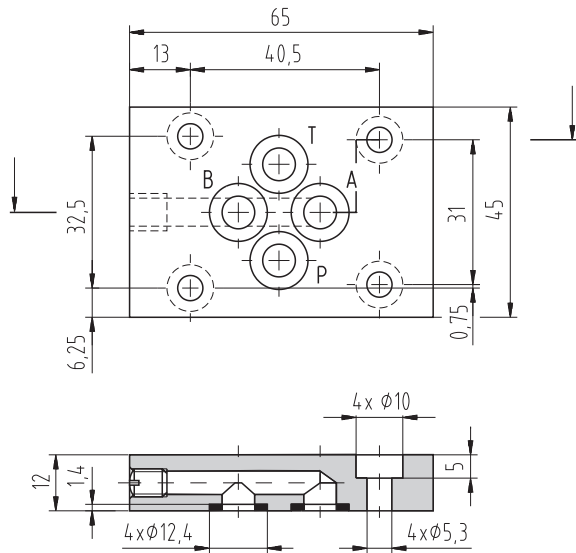

Blanking Plate DK1-06/32-2

Dimensions in mm

Used as universal blanking plate size 06.

Sealing rings	Weight of the plate	Ordering number of the plate
4 pcs. Square rings 9.25 x 1.68	0.32 kg	15933900

Sealing rings are delivered with each plate
(quantity and dimensions see the table above).

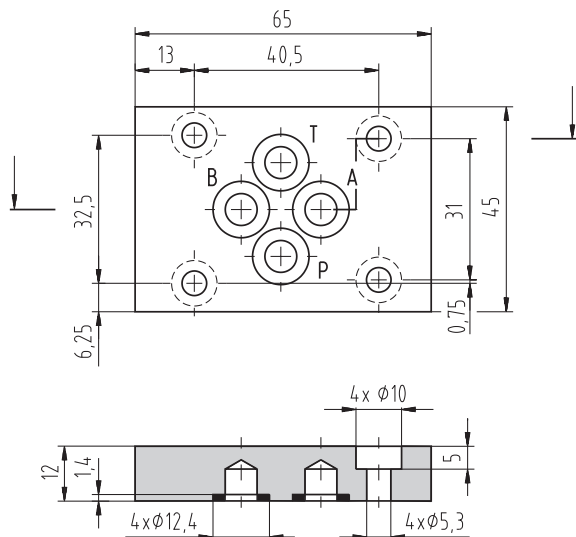

Blanking Plate DK1-06/32-3

Dimensions in mm

Used as universal blanking plate size 06.
Connects ports A and P.

Sealing rings	Weight of the plate	Ordering number of the plate
4 pcs. Square rings 9.25 x 1.68	0.32 kg	15662900

Sealing rings are delivered with each plate
(quantity and dimensions see the table above).

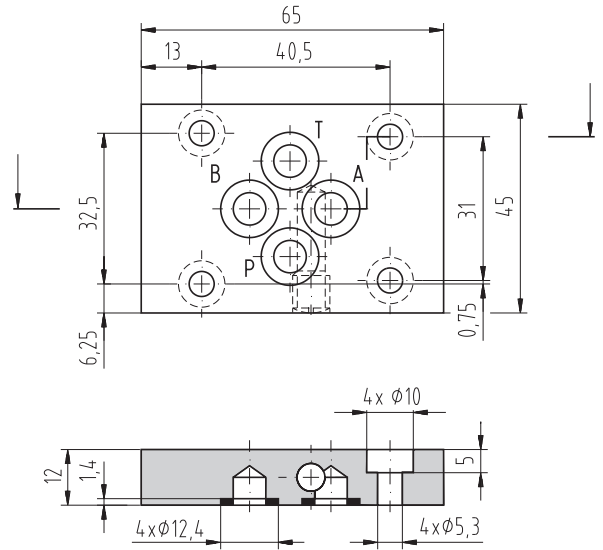

Blanking Plate DK1-10/32-2

Dimensions in mm

Used as universal blanking plate size 10.

Sealing rings	Weight of the plate	Ordering number of the plate
5 pcs. Square rings 12.42 x 1.68	1.00 kg	15936100

Sealing rings are delivered with each plate
(quantity and dimensions see the table above).

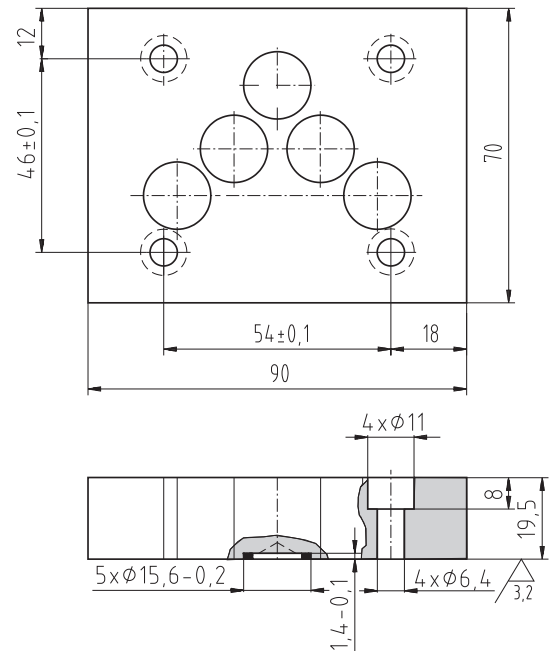

Caution!

- The packing foil is recyclable.
- The technical information regarding the product presented in this catalogue is for descriptive purposes only. It should not be construed in any case as a guaranteed representation of the product properties in the sense of the law.

ARGO-HYTOS s.r.o. CZ - 543 15 Vrchlabí
Tel.: +420-499-403111, Fax: +420-499-403421
E-mail: sales.cz@argo-hytos.com
www.argo-hytos.com

Table of stud kits for vertical stacking assemblies in combination with directional control valve RPE3-04

Pressure switch	Pressure reducing valve	Pressure relief valve	Pilot operated check valve	Check valve	Throttle valve	Studs with rolled threads	Maximum working pressure	Ordering number*
Height 35 mm	Height 30 mm	Height 35 mm	Height 30 mm	Height 30 mm	Height 30 mm	$M_u = 5 \text{ Nm}$	p_{max} bar	
M-TR						M5 x 82	320	16103600
	VRP2-04					M5 x 77	320	16105100
		VPP2-04				M5 x 82	320	16103600
			VJR1-04			M5 x 77	320	16105100
				VJO1-04/M		M5 x 77	320	16105100
					VSO1-04/M	M5 x 77	320	16105100
M-TR	VRP2-04					M5 x 110	320	16103900
M-TR		VPP2-04				M5 x 115	320	16108200
M-TR			VJR1-04			M5 x 110	320	16103900
M-TR				VJO1-04/M		M5 x 110	320	16103900
M-TR					VSO1-04/M	M5 x 110	320	16103900
	VRP2-04	VPP2-04				M5 x 110	320	16103900
	VRP2-04		VJR1-04			M5 x 110	320	16103900
	VRP2-04			VJO1-04/M		M5 x 110	320	16103900
	VRP2-04				VSO1-04/M	M5 x 110	320	16103900
		VPP2-04	VJR1-04			M5 x 110	320	16103900
		VPP2-04		VJO1-04/M		M5 x 110	320	16103900
		VPP2-04			VSO1-04/M	M5 x 110	320	16103900
			VJR1-04	VJO1-04/M		M5 x 110	320	16103900
			VJR1-04		VSO1-04/M	M5 x 110	320	16103900
				VJO1-04/M	VSO1-04/M	M5 x 110	320	16103900
M-TR	VRP2-04	VPP2-04				M5 x 144	320	16104200
M-TR	VRP2-04		VJR1-04			M5 x 144	320	16104200
M-TR	VRP2-04			VJO1-04/M		M5 x 144	320	16104200
M-TR	VRP2-04				VSO1-04/M	M5 x 144	320	16104200
M-TR		VPP2-04	VJR1-04			M5 x 144	320	16104200
M-TR		VPP2-04		VJO1-04/M		M5 x 144	320	16104200
M-TR		VPP2-04			VSO1-04/M	M5 x 144	320	16104200
M-TR			VJR1-04	VJO1-04/M		M5 x 144	320	16104200
M-TR			VJR1-04		VSO1-04/M	M5 x 144	320	16104200
M-TR				VJO1-04/M	VSO1-04/M	M5 x 144	320	16104200
	VRP2-04	VPP2-04	VJR1-04			M5 x 144	320	16104200
	VRP2-04	VPP2-04		VJO1-04/M		M5 x 144	320	16104200
	VRP2-04	VPP2-04			VSO1-04/M	M5 x 144	320	16104200
	VRP2-04		VJR1-04	VJO1-04/M		M5 x 136	320	16104100
	VRP2-04		VJR1-04		VSO1-04/M	M5 x 136	320	16104100
	VRP2-04			VJO1-04/M	VSO1-04/M	M5 x 136	320	16104100

Table of stud kits for vertical stacking assemblies in combination with directional control valve RPE3-04

Pressure switch	Pressure reducing valve	Pressure relief valve	Pilot operated check valve	Check valve	Throttle valve	Studs with rolled threads	Maximum working pressure	Ordering number*
Height 35 mm	Height 30 mm	Height 35 mm	Height 30 mm	Height 30 mm	Height 30 mm	$M_u = 5 \text{ Nm}$	p_{\max} bar	
		VPP2-04	VJR1-04	VJO1-04/M		M5 x 144	320	16104200
		VPP2-04	VJR1-04		VSO1-04/M	M5 x 144	320	16104200
		VPP2-04		VJO1-04/M	VSO1-04/M	M5 x 144	320	16104200
			VJR1-04	VJO1-04/M	VSO1-04/M	M5 x 136	320	16104100
M-TR	VRP2-04	VPP2-04	VJR1-04			M5 x 177	320	16108300
M-TR	VRP2-04	VPP2-04		VJO1-04/M		M5 x 177	320	16108300
M-TR	VRP2-04	VPP2-04			VSO1-04/M	M5 x 177	320	16108300
M-TR	VRP2-04		VJR1-04	VJO1-04/M		M5 x 170	320	16104300
M-TR	VRP2-04		VJR1-04		VSO1-04/M	M5 x 170	320	16104300
M-TR	VRP2-04			VJO1-04/M	VSO1-04/M	M5 x 170	320	16104300
M-TR		VPP2-04	VJR1-04	VJO1-04/M		M5 x 177	320	16108300
M-TR		VPP2-04	VJR1-04		VSO1-04/M	M5 x 177	320	16108300
M-TR		VPP2-04		VJO1-04/M	VSO1-04/M	M5 x 177	320	16108300
M-TR			VJR1-04	VJO1-04/M	VSO1-04/M	M5 x 170	320	16104300
	VRP2-04	VPP2-04	VJR1-04	VJO1-04/M		M5 x 170	320	16104300
	VRP2-04	VPP2-04	VJR1-04		VSO1-04/M	M5 x 170	320	16104300
	VRP2-04	VPP2-04		VJO1-04/M	VSO1-04/M	M5 x 170	320	16104300
	VRP2-04		VJR1-04	VJO1-04/M	VSO1-04/M	M5 x 170	320	16104300
		VPP2-04	VJR1-04	VJO1-04/M	VSO1-04/M	M5 x 170	320	16104300
M-TR	VRP2-04	VPP2-04	VJR1-04	VJO1-04/M		M5 x 210	250	16104700
M-TR	VRP2-04	VPP2-04	VJR1-04		VSO1-04/M	M5 x 210	250	16104700
M-TR	VRP2-04	VPP2-04		VJO1-04/M	VSO1-04/M	M5 x 210	250	16104700
M-TR	VRP2-04		VJR1-04	VJO1-04/M	VSO1-04/M	M5 x 202	250	16105300
M-TR		VPP2-04	VJR1-04	VJO1-04/M	VSO1-04/M	M5 x 210	250	16104700
	VRP2-04	VPP2-04	VJR1-04	VJO1-04/M	VSO1-04/M	M5 x 202	250	16105300

* The order number contains a set of 4 studs and 4 nuts.

Valve Dimensions

Dimensions in millimeters

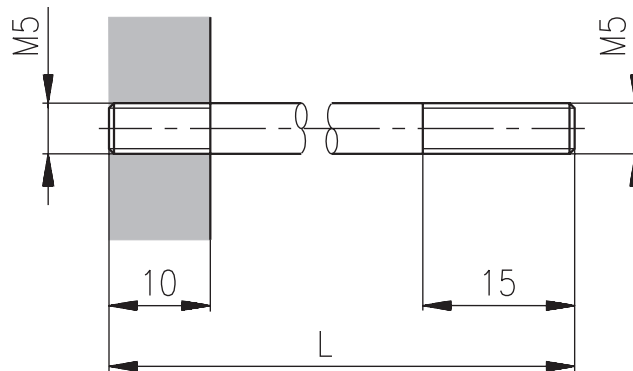
Stud Bolt

Stud bolt M5 x L (length L see the table), class of strength 10.9.

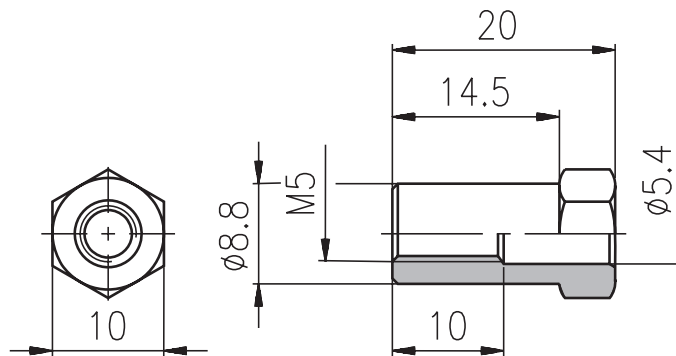
Stud Nut**Order numbers of Individual Stud Bolts and Stud Nuts**

Name	Dimension	Weight/100 pcs (kg)	Ordering number
Stud Bolt	M5 x 77	1.08	309001005077
Stud Bolt	M5 x 82	1.15	309001005082
Stud Bolt	M5 x 110	1.55	309001005110
Stud Bolt	M5 x 115	1.62	309001005115
Stud Bolt	M5 x 136	1.92	309001005136
Stud Bolt	M5 x 144	2.03	309001005144
Stud Bolt	M5 x 170	2.39	309001005170
Stud Bolt	M5 x 177	2.49	309001005177
Stud Bolt	M5 x 202	2.84	309001005202
Stud Bolt	M5 x 210	2.96	309001005210
Stud Nut	M5	0.71	336 677 721 990

Caution!

- The technical information regarding the product presented in this catalogue is for descriptive purposes only. It should not be construed in any case as a guaranteed representation of the product properties in the sense of the law.

ARGO-HYTOS s.r.o. CZ - 543 15 Vrchlabí
Tel.: +420-499-403111, Fax: +420-499-403421
E-mail: sales.cz@argo-hytos.com
www.argo-hytos.com

Table of stud kits for vertical stacking assemblies in combination with directional control valve RPE3-06

Pressure switch	Pressure reducing valve	Pressure relief valve	Pilot operated check valve	Check valve	Throttle valve	Studs with rolled threads	Maximum working pressure	Ordering number*
Height 43 mm	Height 45 mm	Height 40 mm	Height 40 mm	Height 40 mm	Height 40 mm	$M_U = 8.9 \text{ Nm}$	p_{\max} bar	
MTS1-06						M5 x 98	320	16103700
	VRN2-06					M5 x 102	320	16103800
		VPN1-06				M5 x 98	320	16103700
			2RJV1-06			M5 x 98	320	16103700
				MVJ3-06		M5 x 98	320	16103700
					2VS3-06	M5 x 98	320	16103700
MTS1-06	VRN2-06					M5 x 144	320	16104200
MTS1-06		VPN1-06				M5 x 136	320	16104100
MTS1-06			2RJV1-06			M5 x 136	320	16104100
MTS1-06				MVJ3-06		M5 x 136	320	16104100
MTS1-06					2VS3-06	M5 x 136	320	16104100
	VRN2-06	VPN1-06				M5 x 144	320	16104200
	VRN2-06		2RJV1-06			M5 x 144	320	16104200
	VRN2-06			MVJ3-06		M5 x 144	320	16104200
	VRN2-06				2VS3-06	M5 x 144	320	16104200
		VPN1-06	2RJV1-06			M5 x 136	320	16104100
		VPN1-06		MVJ3-06		M5 x 136	320	16104100
		VPN1-06			2VS3-06	M5 x 136	320	16104100
			2RJV1-06	MVJ3-06		M5 x 136	320	16104100
			2RJV1-06		2VS3-06	M5 x 136	320	16104100
				MVJ3-06	2VS3-06	M5 x 136	320	16104100
MTS1-06	VRN2-06	VPN1-06				M5 x 185	320	16104600
MTS1-06	VRN2-06		2RJV1-06			M5 x 185	320	16104600
MTS1-06	VRN2-06			MVJ3-06		M5 x 185	320	16104600
MTS1-06	VRN2-06				2VS3-06	M5 x 180	320	16104500
MTS1-06		VPN1-06	2RJV1-06			M5 x 180	320	16104500
MTS1-06		VPN1-06		MVJ3-06		M5 x 180	320	16104500
MTS1-06		VPN1-06			2VS3-06	M5 x 180	320	16104500
MTS1-06			2RJV1-06	MVJ3-06		M5 x 180	320	16104500
MTS1-06			2RJV1-06		2VS3-06	M5 x 180	320	16104500
MTS1-06				MVJ3-06	2VS3-06	M5 x 180	320	16104500
	VRN2-06	VPN1-06	2RJV1-06			M5 x 185	320	16104600
	VRN2-06	VPN1-06		MVJ3-06		M5 x 185	320	16104600
	VRN2-06	VPN1-06			2VS3-06	M5 x 180	320	16104500
	VRN2-06		2RJV1-06	MVJ3-06		M5 x 180	320	16104500
	VRN2-06		2RJV1-06		2VS3-06	M5 x 180	320	16104500
	VRN2-06			MVJ3-06	2VS3-06	M5 x 180	320	16104500

Table of stud kits for vertical stacking assemblies in combination with directional control valve RPE3-06

Pressure switch	Pressure reducing valve	Pressure relief valve	Pilot operated check valve	Check valve	Throttle valve	Studs with rolled threads	Maximum working pressure	Ordering number*
Height 43 mm	Height 45 mm	Height 40 mm	Height 40 mm	Height 40 mm	Height 40 mm	$M_u = 8.9 \text{ Nm}$	p_{max} bar	
		VPN1-06	2RJV1-06	MVJ3-06		M5 x 175	320	16104400
		VPN1-06	2RJV1-06		2VS3-06	M5 x 175	320	16104400
		VPN1-06		MVJ3-06	2VS3-06	M5 x 175	320	16104400
			2RJV1-06	MVJ3-06	2VS3-06	M5 x 175	320	16104400
MTS1-06	VRN2-06	VPN1-06	2RJV1-06			M5 x 222	250	16104900
MTS1-06	VRN2-06	VPN1-06		MVJ3-06		M5 x 222	250	16104900
MTS1-06	VRN2-06	VPN1-06			2VS3-06	M5 x 222	250	16104900
MTS1-06	VRN2-06		2RJV1-06	MVJ3-06		M5 x 222	250	16104900
MTS1-06	VRN2-06		2RJV1-06		2VS3-06	M5 x 222	250	16104900
MTS1-06	VRN2-06			MVJ3-06	2VS3-06	M5 x 222	250	16104900
MTS1-06		VPN1-06	2RJV1-06	MVJ3-06		M5 x 215	250	16104800
MTS1-06		VPN1-06	2RJV1-06		2VS3-06	M5 x 215	250	16104800
MTS1-06		VPN1-06		MVJ3-06	2VS3-06	M5 x 215	250	16104800
MTS1-06			2RJV1-06	MVJ3-06	2VS3-06	M5 x 215	250	16104800
	VRN2-06	VPN1-06	2RJV1-06	MVJ3-06		M5 x 222	250	16104900
	VRN2-06	VPN1-06	2RJV1-06		2VS3-06	M5 x 222	250	16104900
	VRN2-06	VPN1-06		MVJ3-06	2VS3-06	M5 x 222	250	16104900
	VRN2-06		2RJV1-06	MVJ3-06	2VS3-06	M5 x 222	250	16104900
		VPN1-06	2RJV1-06	MVJ3-06	2VS3-06	M5 x 255	200	16105000
MTS1-06	VRN2-06	VPN1-06	2RJV1-06	MVJ3-06		M5 x 262	200	16105500
MTS1-06	VRN2-06	VPN1-06	2RJV1-06		2VS3-06	M5 x 262	200	16105500
MTS1-06	VRN2-06	VPN1-06		MVJ3-06	2VS3-06	M5 x 262	200	16105500
MTS1-06	VRN2-06		2RJV1-06	MVJ3-06	2VS3-06	M5 x 262	200	16105500
MTS1-06		VPN1-06	2RJV1-06	MVJ2-06	2VS3-06	M5 x 262	200	16105500
	VRN2-06	VPN1-06	2RJV1-06	MVJ3-06	2VS3-06	M5 x 262	200	16105500

* The ordering number contains a set of 4 studs and 4 nuts.

Valve Dimensions

Dimensions in millimeters

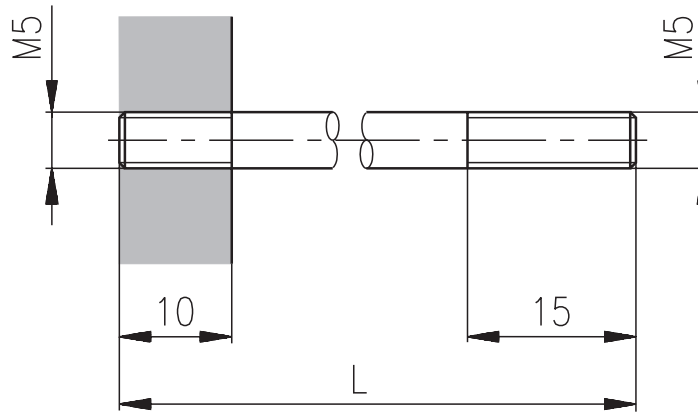
Stud Bolt

Stud bolt M5 x L (length L see the table), class of strength 10.9.

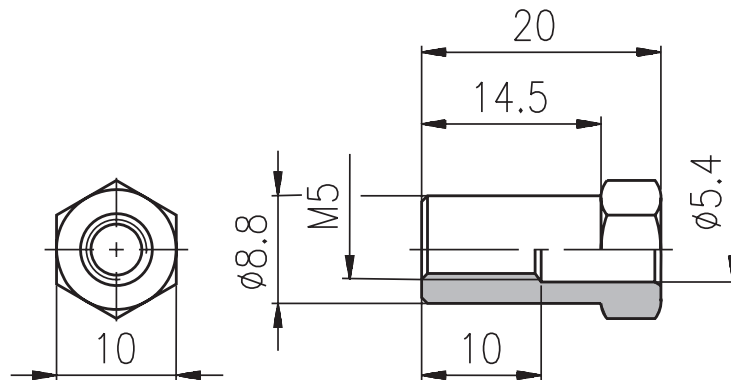
Stud Nut**Order numbers of Individual Stud Bolts and Stud Nuts**

Name	Dimension	Weight/100 pcs (kg)	Ordering number
Stud Bolt	M5 x 88	1.24	309001005088
Stud Bolt	M5 x 98	1.38	309001005098
Stud Bolt	M5 x 102	1.44	309001005102
Stud Bolt	M5 x 130	1.83	309001005130
Stud Bolt	M5 x 136	1.92	309001005136
Stud Bolt	M5 x 144	2.03	309001005144
Stud Bolt	M5 x 170	2.39	309001005170
Stud Bolt	M5 x 175	2.46	309001005175
Stud Bolt	M5 x 180	2.53	309001005180
Stud Bolt	M5 x 185	2.61	309001005185
Stud Bolt	M5 x 210	2.96	309001005210
Stud Bolt	M5 x 215	3.03	309001005215
Stud Bolt	M5 x 222	3.13	309001005222
Stud Bolt	M5 x 250	3.52	309001005250
Stud Bolt	M5 x 255	3.59	309001005255
Stud Bolt	M5 x 262	3.69	309001005262
Nut	M5	0.71	336 677 721 990

Caution!

- The technical information regarding the product presented in this catalogue is for descriptive purposes only. It should not be construed in any case as a guaranteed representation of the product properties in the sense of the law.

ARGO-HYTOS s.r.o.CZ - 543 15 Vrchlaví
Tel.: +420-499-403111, Fax: +420-499-403421
E-mail: sales.cz@argo-hytos.com
www.argo-hytos.com

Table of stud kits for vertical stacking assemblies in combination with directional control valve RPE4-10

Pressure switch	Pressure reducing valve	Pressure relief valve	Pilot operated check valve	Check valve	Throttle valve	Studs with rolled threads	Maximum working pressure	Ordering number*
Height 43 mm	Height 50 mm	Height 50 mm	Height 50 mm	Height 50 mm	Height 50 mm	M _u = 14 Nm	p _{max} bar	
MTS1-10						M6 x 92	320	16106800
	VRN1-10					M6 x 103	320	16106700
		VPN2-10				M6 x 103	320	16106700
			VJR2-10			M6 x 103	320	16106700
				MVJ3-10		M6 x 103	320	16106700
					VSO2-10	M6 x 103	320	16106700
MTS1-10	VRN1-10					M6 x 147	320	16108000
MTS1-10		VPN2-10				M6 x 147	320	16108000
MTS1-10			VJR2-10			M6 x 147	320	16108000
MTS1-10				MVJ3-10		M6 x 147	320	16108000
MTS1-10					VSO2-10	M6 x 147	320	16108000
	VRN1-10	VPN2-10				M6 x 152	320	16107000
	VRN1-10		VJR2-10			M6 x 152	320	16107000
	VRN1-10			MVJ3-10		M6 x 152	320	16107000
	VRN1-10				VSO2-10	M6 x 152	320	16107000
		VPN2-10	VJR2-10			M6 x 152	320	16107000
		VPN2-10		MVJ3-10		M6 x 152	320	16107000
		VPN2-10			VSO2-10	M6 x 152	320	16107000
			VJR2-10	MVJ3-10		M6 x 152	320	16107000
			VJR2-10		VSO2-10	M6 x 152	320	16107000
				MVJ3-10	VSO2-10	M6 x 152	320	16107000
MTS1-10	VRN1-10	VPN2-10				M6 x 199	320	16108100
MTS1-10	VRN1-10		VJR2-10			M6 x 199	320	16108100
MTS1-10	VRN1-10			MVJ3-10		M6 x 199	320	16108100
MTS1-10	VRN1-10				VSO2-10	M6 x 199	320	16108100
MTS1-10		VPN2-10	VJR2-10			M6 x 199	320	16108100
MTS1-10		VPN2-10		MVJ3-10		M6 x 199	320	16108100
MTS1-10		VPN2-10			VSO2-10	M6 x 199	320	16108100
MTS1-10			VJR2-10	MVJ3-10		M6 x 199	320	16108100
MTS1-10			VJR2-10		VSO2-10	M6 x 199	320	16108100
MTS1-10				MVJ3-10	VSO2-10	M6 x 199	320	16108100
	VRN1-10	VPN2-10	VJR2-10			M6 x 203	320	16107300
	VRN1-10	VPN2-10		MVJ3-10		M6 x 203	320	16107300
	VRN1-10	VPN2-10			VSO2-10	M6 x 203	320	16107300
	VRN1-10		VJR2-10	MVJ3-10		M6 x 203	320	16107300
	VRN1-10		VJR2-10		VSO2-10	M6 x 203	320	16107300
	VRN1-10			MVJ32-10	VSO2-10	M6 x 203	320	16107300

Table of stud kits for vertical stacking assemblies in combination with directional control valve RPE4-10

Pressure switch	Pressure reducing valve	Pressure relief valve	Pilot operated check valve	Check valve	Throttle valve	Studs with rolled threads	Maximum working pressure	Ordering number*
Height 43 mm	Height 50 mm	Height 50 mm	Height 50 mm	Height 50 mm	Height 50 mm	$M_u = 14 \text{ Nm}$	p_{max} bar	
		VPN2-10	VJR2-10	MVJ3-10		M6 x 203	320	16107300
		VPN2-10	VJR2-10		VSO2-10	M6 x 203	320	16107300
		VPN2-10		MVJ3-10	VSO2-10	M6 x 203	320	16107300
			VJR2-10	MVJ3-10	VSO2-10	M6 x 203	320	16107300
MTS1-10	VRN1-10	VPN2-10	VJR2-10			M6 x 245	250	16107500
MTS1-10	VRN1-10	VPN2-10		MVJ3-10		M6 x 245	250	16107500
MTS1-10	VRN1-10	VPN2-10			VSO2-10	M6 x 245	250	16107500
MTS1-10	VRN1-10		VJR2-10	MVJ3-10		M6 x 245	250	16107500
MTS1-10	VRN1-10		VJR2-10		VSO2-10	M6 x 245	250	16107500
MTS1-10	VRN1-10			MVJ3-10	VSO2-10	M6 x 245	250	16107500
MTS1-10		VPN2-10	VJR2-10	MVJ3-10		M6 x 245	250	16107500
MTS1-10		VPN2-10	VJR2-10		VSO2-10	M6 x 245	250	16107500
MTS1-10		VPN2-10		MVJ3-10	VSO2-10	M6 x 245	250	16107500
MTS1-10			VJR2-10	MVJ3-10	VSO2-10	M6 x 245	250	16107500
	VRN1-10	VPN2-10	VJR2-10	MVJ3-10		M6 x 253	250	16107800
	VRN1-10	VPN2-10	VJR2-10		VSO2-10	M6 x 253	250	16107800
	VRN1-10	VPN2-10		MVJ3-10	VSO2-10	M6 x 253	250	16107800
	VRN1-10		VJR2-10	MVJ3-10	VSO2-10	M6 x 253	250	16107800
		VPN2-10	VJR2-10	MVJ3-10	VSO2-10	M6 x 253	250	16107800
MTS1-10	VRN1-10	VPN2-10	VJR2-10	MVJ3-10		M6 x 295	200	16107700
MTS1-10	VRN1-10	VPN2-10	VJR2-10		VSO2-10	M6 x 295	200	16107700
MTS1-10	VRN1-10	VPN2-10		MVJ3-10	VSO2-10	M6 x 295	200	16107700
MTS1-10	VRN1-10		VJR2-10	MVJ3-10	VSO2-10	M6 x 295	200	16107700
MTS1-10		VPN2-10	VJR2-10	MVJ3-10	VSO2-10	M6 x 295	200	16107700
	VRN1-10	VPN2-10	VJR2-10	MVJ3-10	VSO2-10	M6 x 306	200	30149900

* The ordering number contains a set of 4 studs and 4 nuts.

Valve Dimensions

Dimensions in millimeters

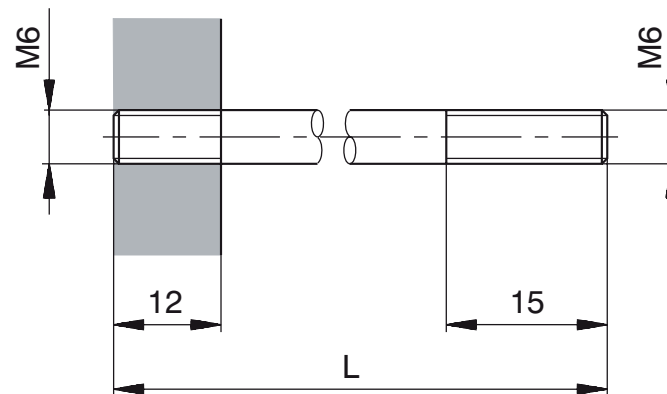
Stud Bolt

Stud bolt M6 x L (length L see the table), class of strength 10.9.

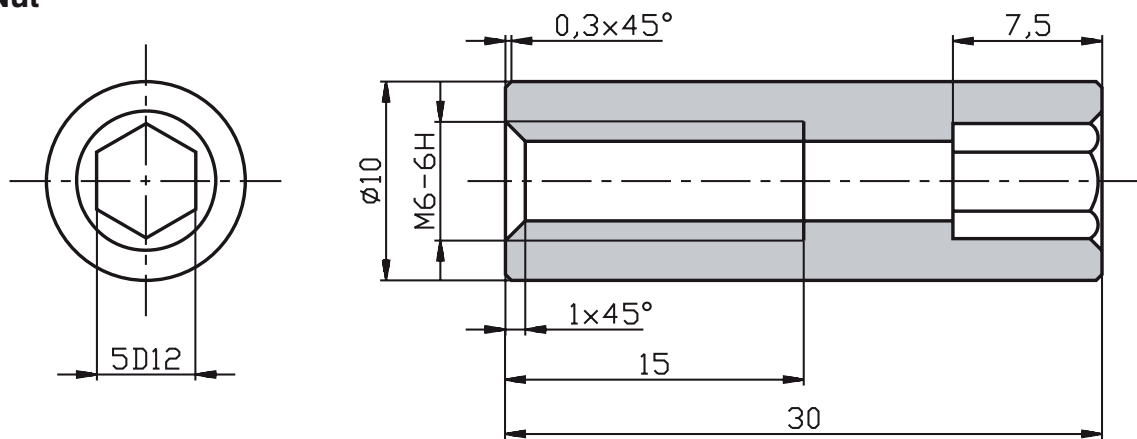
Stud Nut**Ordering numbers of individual stud bolts and stud nuts**

Name	Dimension	Weight/100 pcs (kg)	Ordering number
Stud Bolt	M6 x 92	1.9	309001006092
Stud Bolt	M6 x 103	2.1	309001006103
Stud Bolt	M6 x 136	2.8	309001006136
Stud Bolt	M6 x 143	3.0	309001006143
Stud Bolt	M6 x 147	3.1	309001006147
Stud Bolt	M6 x 152	3.2	309001006152
Stud Bolt	M6 x 187	4.0	309001006187
Stud Bolt	M6 x 194	4.1	309001006194
Stud Bolt	M6 x 199	4.2	309001006199
Stud Bolt	M6 x 203	4.3	309001006203
Stud Bolt	M6 x 236	5.0	309001006236
Stud Bolt	M6 x 245	5.2	309001006245
Stud Bolt	M6 x 253	5.5	309001006253
Stud Bolt	M6 x 287	6.1	309001006287
Stud Bolt	M6 x 295	6.4	309001006295
Stud Nut	M6 x 306	6,6	24233600
Nut	M6	1.31	16115200

Caution!

- The technical information regarding the product presented in this catalogue is for descriptive purposes only. It should not be construed in any case as a guaranteed representation of the product properties in the sense of the law.

ARGO-HYTOS s.r.o. CZ - 543 15 Vrchlabí
Tel.: +420-499-403111, Fax: +420-499-403421
E-mail: sales.cz@argo-hytos.com
www.argo-hytos.com

3/4-16UNF; 7/8-14UNF; M20x1,5; M22x1,5; M27x2; G1/8

- Standard Cavity Plugs are used as replacements for valves with cavity sizes 3/4-16UNF; 7/8-14UNF; M20x1,5; M22x1,5; M27x2 and G1/8
- Standard Cavity Plugs seal all access to the cavities. Special Cavity Plugs can be made since the Cavity Plugs have a hole drilled in axial direction. In drilling additional radial holes several functions can be created. Size and location of these holes must be according to the standard cavities.
- Sealing of the Cavity Plugs is identical to the seals of the same valve type
- The Cavity Plugs are zinc coated



Technical Data

Hydraulic fluid	Hydraulic oils of power classes (HL, HLP) to DIN 51524
Fluid temperature range (NBR) °C (°F)	-30 ... +100 (-22 ... +212)
Maximum degree of fluid contamination	Class 21/18/15 according to ISO 4406
Mounting position	unrestricted

Types, Selection and Application

Thread Size of Cavity	The number of Valve cavities of the Specific Component	Code of the Valve, witch is replaced by the Cavity Plugs	Ordering Code	Weight (kg/lb)	Torgue (Nm/lbfft)	Operating Pressure (bar/~PSI)
3/4-16UNF	2	SD2E-A2	15960800	0.07 / 0.154	120 / 88.51	420 / 6090
		SD3E-A2				
		SD1E-A2				
		SD1M-A2				
		SC1F-A2				
		SR1A-A2				
	SF22A-A2					
	3	SD2E-A3	22751900	0.08 / 0.176	120 / 88.51	420 / 6090
		SP2A-A3				
SC1F-A3						
4	SD2E-A4	22752000	0.09 / 0.198	120 / 88.51	420 / 6090	
7/8-14UNF	2	SD3E-B2	19356300	0.10 / 0.220	150 / 110.63	420 / 6090
		SC1F-B2				
		SR1A-B2				
		SR4A-B2				
		SR4P-B2				
	3	SD2E-B3	19356900	0.12 / 0.265	150 / 110.63	420 / 6090
		SP4A-B3				
		SP4P-B3				
	SFD2F-B3					
	4	SD2E-B4	19357300	0.14 / 0.309	150 / 110.63	420 / 6090
M20x1,5	3	PVRM1-063	19434000	0.10 / 0.220	60 / 44.26	50 / 725
M22x1,5	2	ROE3	19433200	0.09 / 0.198	80 / 59.00	350 / 5075
		VPN1-06				
		VPP2-04				
3	VRN2-06	19433400	0.11 / 0.243	80 / 59.00	320 / 4640	
M27x2	2	VPN2-10	19433600	0.18 / 0.397	120 / 88.51	350 / 5075
	3	VRN2-10	24493100	0.20 / 0.441	120 / 88.51	320 / 4640
G1/8	3	LV1-043	19433800	0.01 / 0.022	12 / 8.85	500 / 7250

The Cavity Plugs for 2 Way Valves

Dimensions in millimeters (inches)

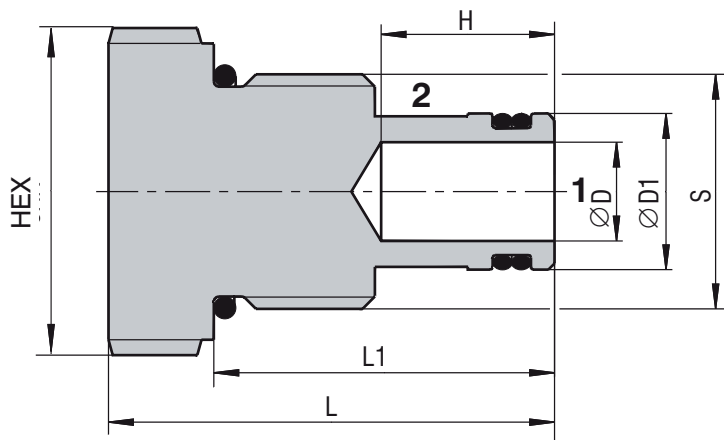

S	HEX	L	L1	Ø D	H	Ø D1
3/4-16UNF	24 (0.945)	36 (1.417)	27,5 (1.083)	8 (0.135)	14 (0.551)	12,65 (0.498)
7/8-14UNF	27 (1.063)	43 (1.693)	33 (1.299)	10 (0.394)	19 (0.748)	15,82 (0.623)
M22x1,5	27 (1.063)	38 (1.496)	28 (1.102)	12 (0.472)	18 (0.709)	18 (0.709)
M27x2	32 (1.260)	58 (2.283)	46 (1.811)	13,5 (0.532)	32 (1.260)	23 (0.906)

The Cavity Plugs for 3 Way Valves

Dimensions in millimeters (inches)

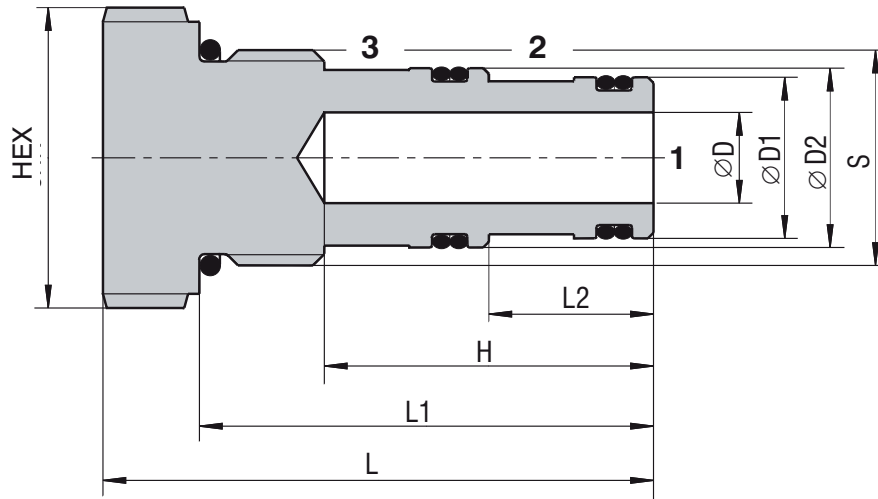

S	HEX	L	L1	L2	Ø D	H
3/4-16UNF	24 (0.945)	48.5 (1.909)	40 (1.575)	14.5 (0.571)	8 (0.135)	29 (1.142)
7/8-14UNF	27 (1.063)	57 (2.244)	47 (1.850)	16.5 (0.650)	10 (0.394)	33 (1.299)
M20x1,5	24 (0.945)	55 (2.165)	45 (1.772)	16 (0.630)	10 (0.394)	32 (1.260)
M22x1,5	27 (1.063)	51 (2.008)	41 (1.615)	14.5 (0.571)	10 (0.394)	31 (1.220)
M27x2	32 (1.260)	63 (2.480)	51 (2.008)	21 (0.827)	12 (0.472)	36 (1.417)

S	Ø D1	Ø D2
3/4-16UNF	14.22 (0.560)	15.82 (0.623)
7/8-14UNF	15.82 (0.623)	17.42 (0.686)
M20x1,5	15.40 (0.606)	16.90 (0.665)
M22x1,5	17.50 (0.689)	18.00 (0.709)
M27x2	21.00 (0.827)	23.00 (0.906)

The Cavity Plugs for 4 Way Valves

Dimensions in millimeters (inches)

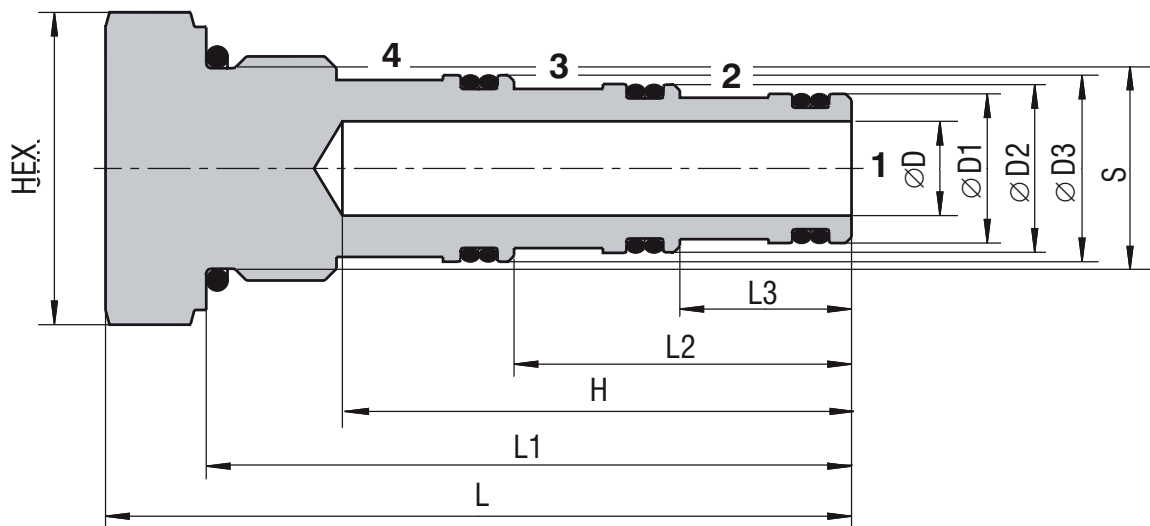

S	HEX	L	L1	L2	L3	Ø D	H
3/4-16UNF	24 (0.945)	63 (2.480)	54.5 (2.146)	28.5 (1.122)	14.5 (0.571)	8 (0.135)	43 (1.693)
7/8-14UNF	27 (1.063)	70.5 (2.776)	60.5 (2.382)	31 (1.220)	15 (0.591)	10 (0.394)	46 (1.811)

S	Ø D1	Ø D2	Ø D3
3/4-16UNF	12.65 (0.498)	14.22 (0.560)	15.82 (0.623)
7/8-14UNF	15.82 (0.623)	17.42 (0.686)	19.00 (0.748)

8

The Cavity Plugs with Hexagon Socket (for LV1-043) Dimensions in millimeters (inches)

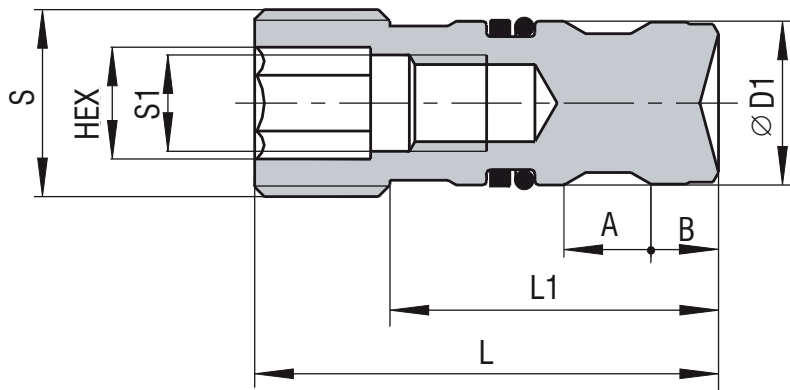

S	HEX	L	L1	S1	Ø D1	A	B
G 1/8	5 (0.197)	24 (0.945)	17 (0.669)	5 (0.197)	8.5 (0.335)	4.5 (0.177)	3.5 (0.138)

Caution!

- The plastic packaging is recyclable.
- Certified documentation is available per request.

ARGO-HYTOS s.r.o. CZ - 543 15 Vrchlabí
 tel.: +420-499-403111, fax: +420-499-403421
 e-mail: sales.cz@argo-hytos.com
 www.argo-hytos.com

3 Way Cavity 3/4-16 UNF-2B

Dimensions in millimeters (inches)

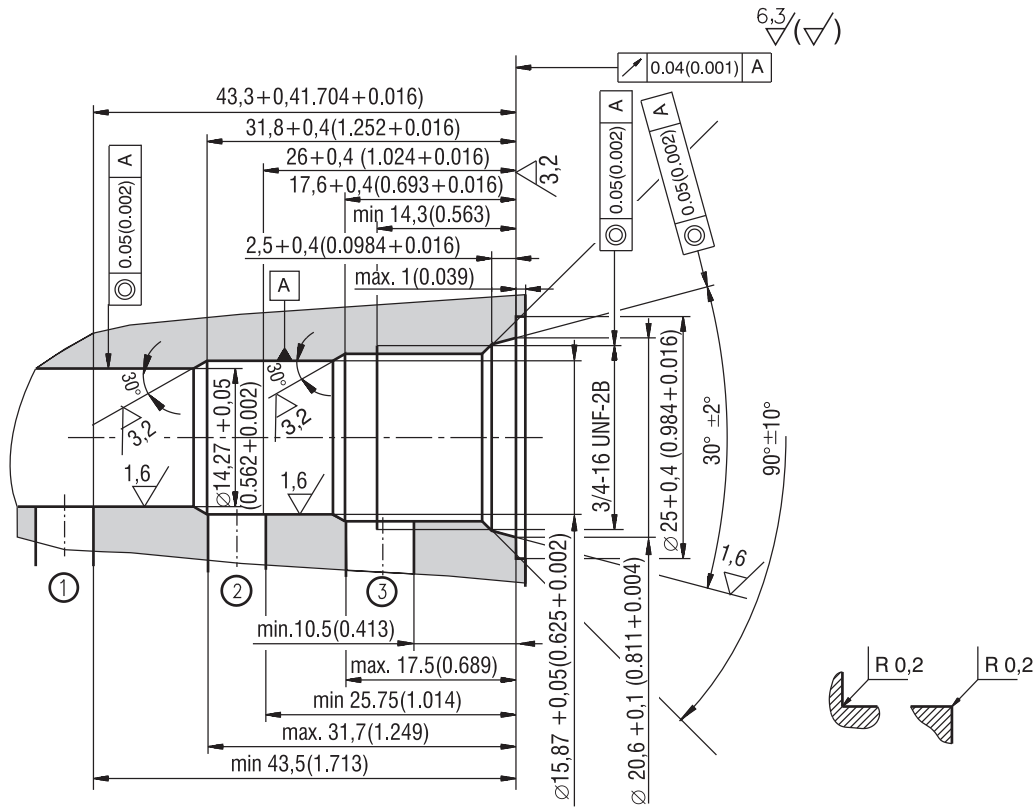

Surface roughness Ra
 Untolerated dimension according to the ISO 2768 -m

8

Cutting Conditions for HSSE Tools

Cavity tools: 3/4-16 UNF-2B with 3 ways		Drill	Forming drill	Forming reamer	Screw tap
Revolutions in 1/min	Aluminium	1660	480	300	150
	Steel	700	200	170	80
Feeding in mm (inch)	Aluminium	250 (9.842)	110 (4.331)	100 (3.937)	-
	Steel	100 (3.937)	50 (1.968)	50 (1.968)	-
Type code		SMT-A3-B	SMT-A3-D	SMT-A3-R	SMT-A2,A3,A4-T
Ordering number		25974600	15604600	1564700	15605000

4 Way Cavity 3/4-16 UNF-2B

Dimensions in millimeters (inches)

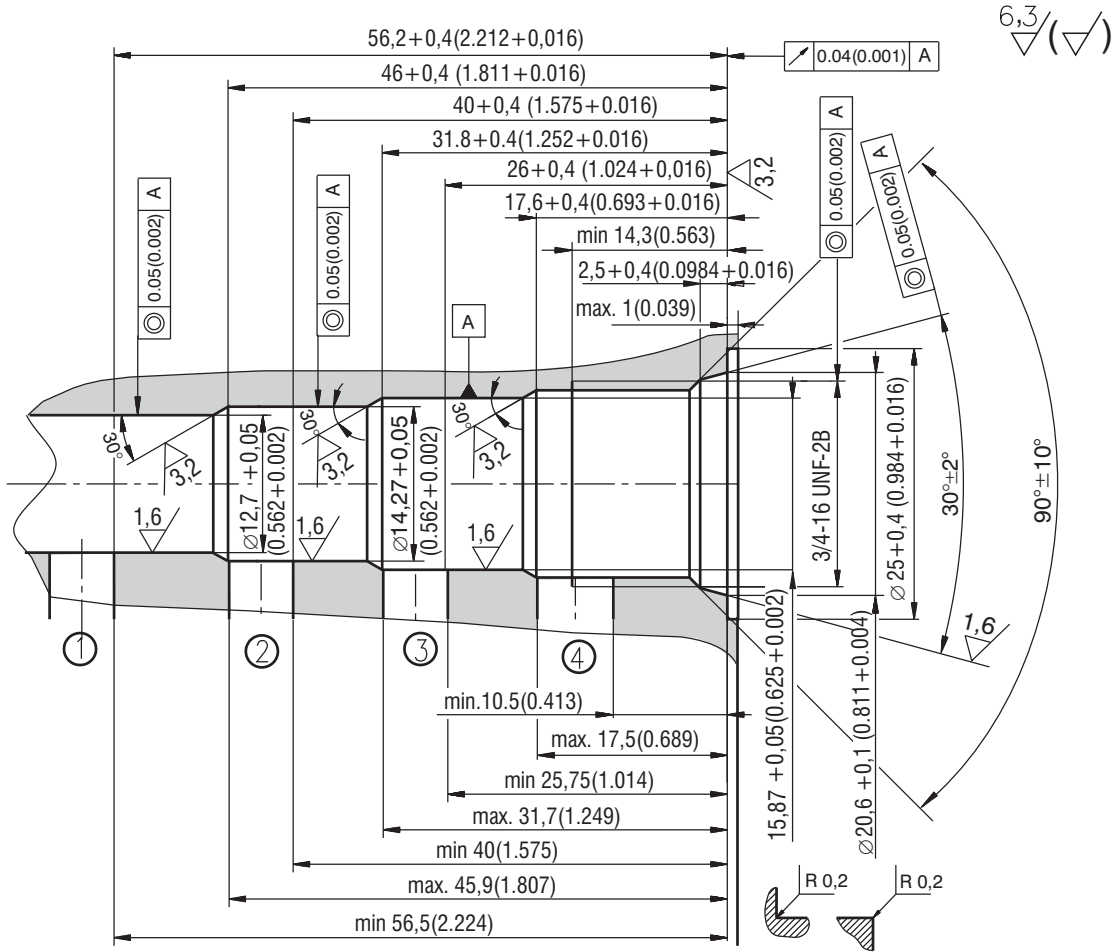

Surface roughness Ra
 Untolerated dimension according to the ISO 2768 -m

Cutting Conditions for HSSE Tools

Cavity tools: 3/4-16 UNF-2B with 4 ways		Drill	Forming drill	Forming reamer	Screw tap
Revolutions in 1/min	Aluminium	1660	480	300	150
	Steel	700	200	170	80
Feeding In mm (inch)	Aluminium	250 (9.842)	110 (4.331)	100 (3.937)	-
	Steel	100 (3.937)	50 (1.968)	50 (1.968)	-
Type code		SMT-A4-B	SMT-A4-D	SMT-A4-R	SMT-A2,A3,A4-T
Ordering number		25974700	15604800	1564900	15605000

2 Way Cavity 7/8-14 UNF-2B

Dimensions in millimeters (inches)

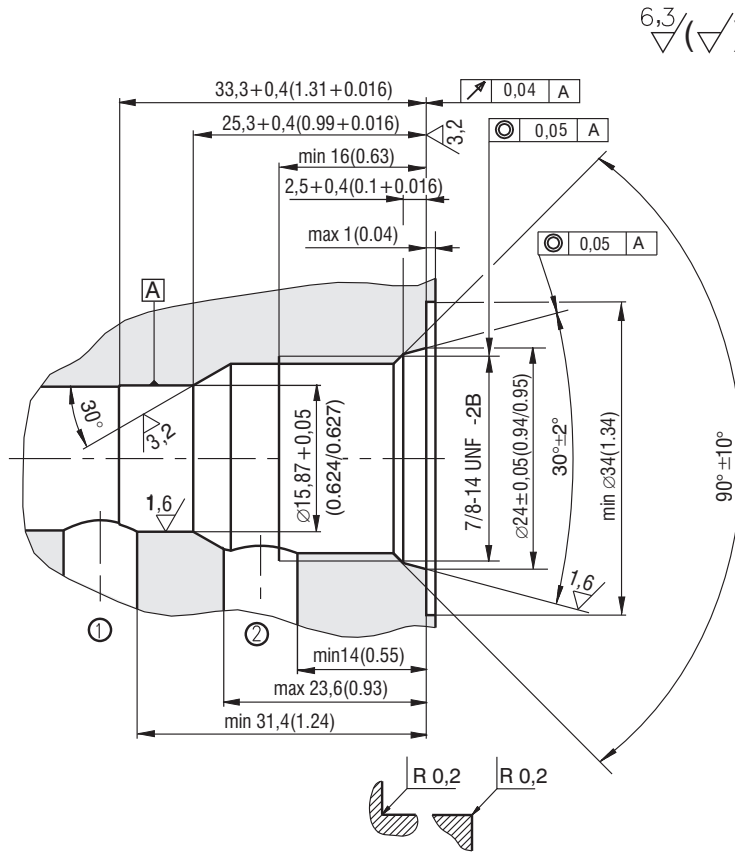

Surface roughness Ra
 Untolerated dimension according to the ISO 2768 -m

8

Cutting Conditions for HSSE Tools

Cavity tools: 7/8-14 UNF-2B with 2 ways		Drill	Forming drill	Forming reamer	Screw tap
Revolutions in 1/min	Aluminium	1300	430	200	150
	Steel	550	170	100	80
Feeding In mm (inch)	Aluminium	200 (7.874)	110 (4.331)	80 (3.150)	-
	Steel	50 (1.968)	40 (1.575)	40 (1.575)	-
Type code		SMT-B2-B	SMT-B2-D	SMT-B2-R	SMT-B2,B3,B4-T
Ordering number		27787000	27787100	27787400	27788100

3 Way Cavity 7/8-14 UNF-2B

Dimensions in millimeters (inches)

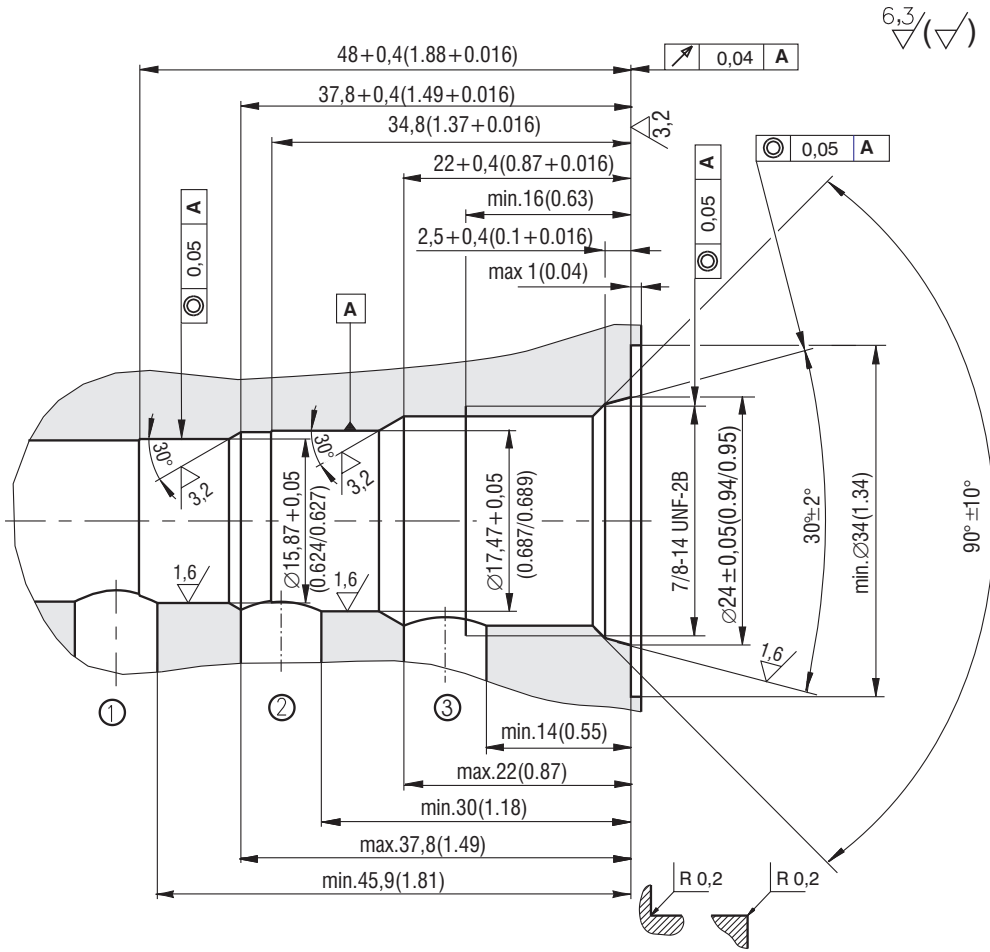

Surface roughness Ra
 Untolerated dimension according to the ISO 2768 -m

Cutting Conditions for HSSE Tools

Cavity tools: 7/8-14 UNF-2B with 3 ways		Drill	Forming drill	Forming reamer	Screw tap
Revolutions in 1/min	Aluminium	1300	410	200	150
	Steel	550	170	100	80
Feeding in mm (inch)	Aluminium	200 (7.874)	100 (3.937)	80 (3.150)	-
	Steel	50 (1.968)	40 (1.575)	40 (1.575)	-
Type code		SMT-B3-B	SMT-B3-D	SMT-B3-R	SMT-B2,B3,B4-T
Ordering number		27787000	27787200	27787600	27788100

4 Way Cavity 7/8-14 UNF-2B

Dimensions in millimeters (inches)

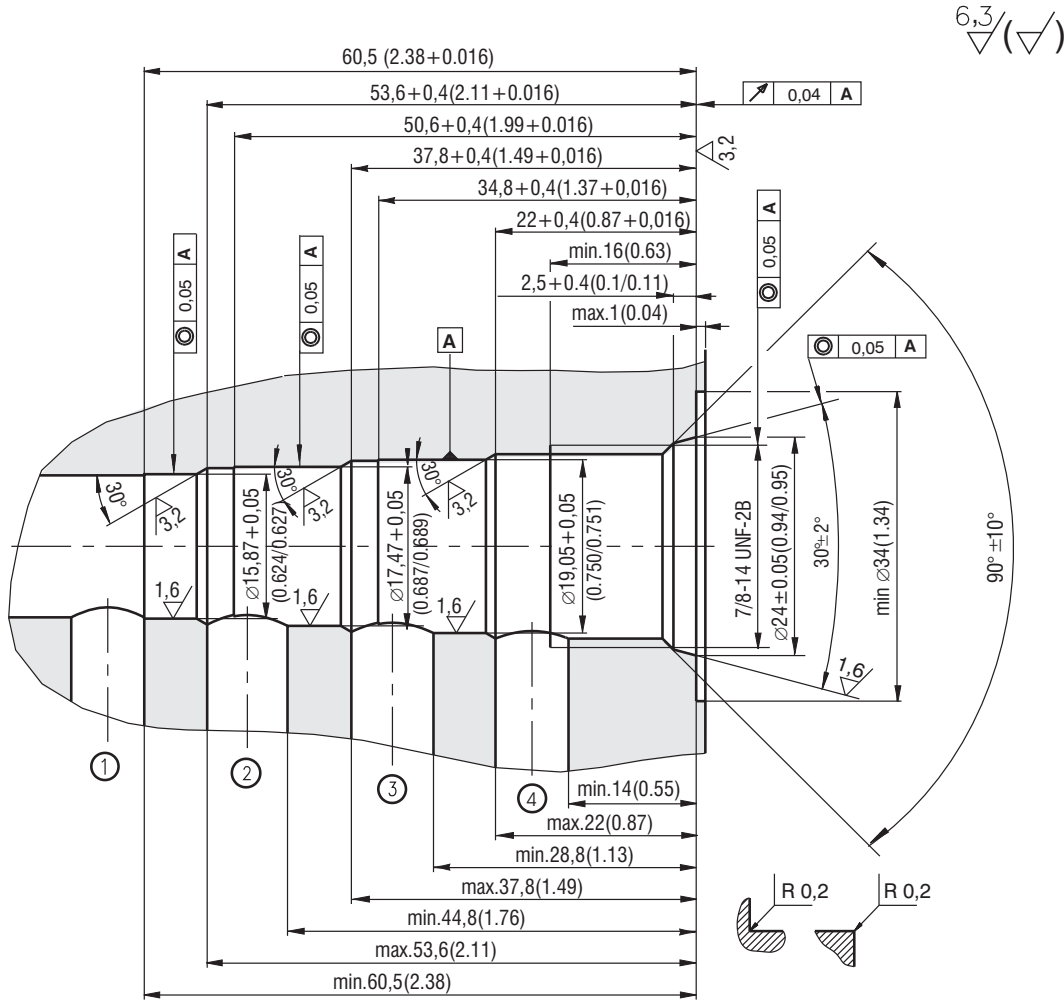

Surface roughness Ra
 Untolerated dimension according to the ISO 2768 - m

Cutting Conditions for HSSE Tools

Cavity tools: 7/8-14 UNF-2B with 4 ways		Drill	Forming drill	Forming reamer	Screw tap
Revolutions in 1/min	Aluminium	1300	410	200	150
	Steel	550	170	100	80
Feeding in mm (inch)	Aluminium	200 (7.874)	100 (3.937)	80 (3.150)	-
	Steel	50 (1.968)	40 (1.575)	40 (1.575)	-
Type code		SMT-B4-B	SMT-B4-D	SMT-B4-R	SMT-B2,B3,B4-T
Ordering number		27787000	27787300	27787900	27788100

Caution!

- The packing foil is recyclable.
- The technical information regarding the product presented in this catalogue is for descriptive purposes only. It should not be construed in any case as a guaranteed representation of the product properties in the sense of the law.

ARGO-HYTOS s.r.o. CZ - 543 15 Vrchlabí
 Tel.: +420-499-403111, Fax: +420-499-403421
 E-mail: sales.cz@argo-hytos.com
 www.argo-hytos.com

We produce fluid power solutions



www.argo-hytos.com



ARGO-HYTOS subsidiaries

Brazil	ARGO-HYTOS AT Fluid Power Systems Ltda.	Rod. Edgard Máximo Zambotto, KM 64 BR-Jarinu - São Paulo	Tel. + 55 11 4016-8300 info.br@argo-hytos.com
Benelux	ARGO-HYTOS B.V.	Zwarte Zee 44 NL-3144 DE Maassluis	Tel. + 31 10 59 26 149 info.benelux@argo-hytos.com
China	ARGO-HYTOS Hong Kong Ltd.	Unit 17, 19/F., Tower B, Regent Centre, 70 Ta Chuen Ping Street, HK-Kwai Chung, New Territories, Hong Kong	Tel. + 852 2485 3131 info.hk@argo-hytos.com
	ARGO-HYTOS Fluid Power Systems (Beijing) Co.Ltd.	10 A, No.15 Jingsheng South Four Street, Jinqiao Science Park, Tongzhou Park of Zhongguancun Science Park, Tongzhou District, CN-Beijing 101102	Tel. +86 10 60507562 info.cn@argo-hytos.com
Czech Republic	ARGO-HYTOS s.r.o.	Dělnická 1306 CZ-543 15 Vrchlabí	Tel. +420 499 403 111 info.cz@argo-hytos.com
	ARGO-HYTOS Protech s.r.o.	Pohraniční 27 CZ-70602 Ostrava-Vítkovice	Tel. + 420 595 956 776 info.protech@argo-hytos.com
France	ARGO-HYTOS SARL	7,rue des Freres Rémy F-57200 Sarreguemines	Tel. + 33 387 28 53 30 info.fr@argo-hytos.com
Germany	ARGO-HYTOS GMBH	Industriestraße 9 D-76703 Kraichtal-Menzingen	Tel. + 49 7250 76 0 info.de@argo-hytos.com
Great Britain	ARGO-HYTOS Ltd.	6A Aspen Court, Aspen Way, Centurion Business Park GB-Rotherham, S60 1FB	Tel. + 44 1709 83 93 00 info.gb@argo-hytos.com
India	ARGOHTOS PVT.LTD.	SF. No. 82B/2B, 85/2, Sandegoundanpalayam Kovilpalayam post, Pollachi taluk, Coimbatore district, 642110	Tel. + 91 4259 259 254 info.in@argo-hytos.com
		D-3148, Oberoi Garden Estate, Chandivali Farm Road Chandivali, Mumbai - 400 072	Tel. +91 2228 575 603 info.in@argo-hytos.com
Italy	ARGO-HYTOS srl	Via Del Girasole 51 IT-41010 San Damaso, Modena	Tel. + 39 059 468018 info.it@argo-hytos.com
Poland	ARGO-HYTOS Polska sp. z o.o.	Ul.Kochanowskiego 3 PL-34100 Wadowice	Tel. + 48 33 873 16 52 info.pl@argo-hytos.com
Scandinavia	ARGO-HYTOS Nordic AB	Pilotgatan 5 SE-21239 Malmö	Tel. +46(0)40 18 77 10 info.se@argo-hytos.com
USA	ARGO-HYTOS Inc.	1835 North Research Drive USA-Bowling Green, Ohio 43402	Tel. + 1 419 353 6070 info.us@argo-hytos.com

Distribution partners

Further distribution partners worldwide you will find in the Internet at www.argo-hytos.com